



# 13<sup>TH</sup> INTERNATIONAL RESEARCH CONFERENCE

HOLISTIC APPROACH TO **NATIONAL GROWTH** AND **SECURITY**

15<sup>TH</sup> - 16<sup>TH</sup> OCTOBER 2020

Computing

PROCEEDINGS



General Sir John Kotelawala Defence University



# 13<sup>TH</sup> INTERNATIONAL RESEARCH CONFERENCE

HOLISTIC APPROACH TO NATIONAL GROWTH AND SECURITY

COMPUTING

# PROCEEDINGS



General Sir John Kotelawala Defence University

Ratmalana, Sri Lanka



©General Sir John Kotelawala Defence University  
All rights reserved

This book contains the Conference Proceedings of the Computing Sessions of the 13<sup>th</sup> International Research Conference of General Sir John Kotelawala Defence University, Ratmalana, Sri Lanka held on 15<sup>th</sup> and 16<sup>th</sup> of October 2020. No part of this publication may be reproduced, stored in a retrieval system or transmitted in any form, without prior permission of General Sir John Kotelawala Defence University, Ratmalana, Sri Lanka.

**Published by**

General Sir John Kotelawala Defence University, Ratmalana, Sri Lanka

Tel: +94-71-021-9425  
e-Mail: irc2020@kdu.ac.lk  
Website: <https://www.kdu.ac.lk/irc2020>

**ISBN 978-624-5574-17-9**

**Other Proceedings of the Conference:**

Defence and Strategic Studies : ISBN 978-624-5574-12-4

Medicine : ISBN 978-624-5574-13-1

Engineering: ISBN 978-624-5574-14-8

Law : ISBN 978-624-5574-15-5

Management, Social Sciences and Humanities : ISBN 978-624-5574-16-2

Allied Health Sciences: ISBN 978-624-5574-18-6

Built Environment and Spatial Sciences: ISBN 978-624-5574-19-3

Basic and Applied Sciences : ISBN 978-624-5574-20-9

**Published on**  
15<sup>th</sup> October 2020

**Cover page designed by**  
Malith Ileperuma

**e-Book Version**

**Platinum Sponsors**



**Co Sponsor**

**Abans**

### **Patron, Conference Steering Committee**

Maj Gen MP Peiris RWP RSP USP ndc psc, Vice Chancellor

### **President, Steering Committee**

Brig N Hathurusinghe psc IG Hdmc

### **Conference Chair**

Dr L Pradeep Kalansooriya

### **Conference Secretariat**

Dr Sanath de Silva

Ms NKK Mudalige

Dr (Ms) NS Fernando

Capt DDGR Karunarathne

### **Steering Committee**

Brig RGU Rajapakshe RSP psc

Cmde JU Gunaseela psc

Col ULJS Perera RSP USP psc

Col WMNKD Bandara RWP RSP USP psc

Capt (S) WM Senevirathna

Lt Col AK Peiris RSP

Squadron Leader WNI Yalagama

Prof MHJ Ariyaratne

Snr Prof SRD Alwis Senevirathne

Snr Prof JR Lucas

Snr Prof ALS Mendis

Snr Prof ND Warnasuriya

Snr Prof RN Pathirana

Snr Prof SSSBDAA Jayawardane

Prof CL Goonasekara

Mr VD Kithsiri

Dr UG Rajapaksha

Dr KMGP Premadasa

Dr (Ms) ADM Gunasekara

Dr JMKB Jayasekara

Mr MPC Wijesooriya

Ms ND Ranasinghe

## Editorial Committee

Mr. WAAK Amaratunga – President

Cmde JU Gunaseela USP psc

Col ULJS Perera RSP USP psc

Capt (E) MCP Dissanayaka

Maj (Dr) WMMS Bandara

Snr Prof Amal Jayawardane

Prof W Abeywickreme

Dr US Rahubadda

Mr PDDD Wickramasinghe

Dr HL Premaratne

Dr S Fernando

Ms BDK Anandawansa

Dr DDTK Kulathunga

Dr R Vijitha

Ms Lakshani Willarachchi

## Panel of Reviewers

Mrs JI Abegoonawardana  
Maj JPWK Abeyawickrama  
Dr RMTB Abeyratne  
Dr Bandula Abeysinghe  
Dr Ujitha Abeywickrama  
Dr MPKW Abhayasinghe  
Dr De Alvis  
Mr WM Amaradasa  
Dr AATD Amarasekera  
Dr Niranga Amarasinghe  
Mr WAAK Amaratunga  
Dr KR Ambepitiya  
Ms BDK Anandawansa  
Dr Anuradha Ariyaratne  
Dr Kusalika Ariyaratne  
Prof MHJ Ariyaratne  
Mrs Iresha Ariyasingha  
LCdr RDS Arunapriya  
Prof Bandunee Athapattu  
Dr Iresha Attanayake  
Dr ME Balasooriya  
Mr DN Balasuriya  
Col (Prof) Aindralal Balasuriya  
Mr Ravimal Bandara  
Dr Wasala Bandara  
Dr RMPS Bandara  
Dr AWMKK Bandara  
Mr KPSPK Bandara  
Dr Yapa Mahinda Bandara  
Lt Col (Dr) WMMS Bandara  
Eng Prabath Buddika  
Dr Thushara Chaminda  
Dr SP Chaminda  
Dr KVDS Chathuranga  
Dr Senarath Colombage  
Dr Amali Dalpadadu  
Eng SU Dampage  
Dr Damayanthi Dasanayake  
Dr WAR De Mel  
Ms LM De Silva  
Dr Sara De Silva  
Mr KSC De Silva  
Prof Nelun de Silva  
Dr Dulantha de Silva  
Dr Darshan de Silva  
Dr Seneetha de Silva  
Mrs MMKOK de Silva  
Dr Anjula De Silva  
Mrs SCM de S Sirisuriya  
Ms R Devi  
Mr HKA Dharmasiri  
Mrs Umada Dikwatta  
Capt MCP Dissanayaka  
Ms AA Edirisinghe  
SqN Ldr Dinusha Edirisinghe  
Dr EATA Edirisuriya  
Dr Chamira Edusooriya  
Dr CD Ekanayake  
Dr Ruwan Ferdinando  
Dr Sithara Fernando  
Dr TGI Fernando  
Cdr Sarath Fernando  
Dr Lakshitha Fernando  
Snr Prof PR Fernando

Dr Neil Fernando  
Dr NS Fernando  
Snr Prof Rohini Fernandopulle  
Ms Madushika W.K Gamage  
Dr AU Gamage  
Mrs Anjalee Gamage  
Archd DWK Gayantha  
Dr Ayantha Gomes  
Dr Kishara Goonerathne  
Dr BGDS Govindapala  
Prof DMA Gunaratna  
Dr NK Gunasekara  
Dr ADAI Gunasekara  
Prof CL Gunasekara  
Mr GP Gunasinghe  
Dr MDEK Gunathilaka  
Dr HRWP Gunathilake  
Mr MMLC Gunathilake  
Dr Buddhika Gunawardana  
Prof Sampath Gunawardana  
Dr SHNP Gunawickrama  
Prof KBS Gunawickrama  
Dr ADAI Gunasekera  
Dr GN Duminda Guruge  
Mr SMB Harshanath  
Miss Ayesha Herath  
Mr HMN Herath  
Dr R Herath  
Dr Janith Hettiarachchi  
Dr B Hettige  
Dr Kanthi Hettigoda  
Mr Dulitha Hewadikaram  
Dr Asiri Hewamalage  
Dr IMPS Ilankoon  
Dr RP Illeperuma  
Ms WMKS Ilmini  
Dr B Indrarathne  
Ms JAD Jayakody  
Dr JMKB Jayasekara  
Dr Priyamali Jayasekara  
Ms BKM Jayasekera  
Dr SD Jayasooriya  
Dr WJABN Jayasuriya  
Mrs JADUN Jayasuriya  
Dr MRS Jayathilake  
Snr Prof Amal Jayawardana  
Dr MM Jayawardana  
Dr Kaushalya Jayaweera  
Dr Janathanan Jeyakumar  
Dr Kasun Jinasena  
Ms Gayanthi John  
Maj (Dr) Darshitha Jothipala  
Dr Thilini Kananke  
Ms SU Kankanamge  
Dr GD Kapila Kumara  
Capt DDGR Karunaratne  
Dr AMDS Karunaratna  
Dr PPCR Karunasekara  
Mr RDN Karunathilake  
Mr RPS Kathriarachchi  
Dr Gnanaselvam Kisokanth  
Dr Saman Koswatte  
Dr DU Kottahachchi  
Mr DMR Kulasekara

Dr DDTK Kulathunga  
Dr RP Kumanayake  
Mr PPNV Kumara  
Archt WAPS Kumara  
Dr KMN Kumarasinghe  
Dr KDKP Kumari  
Dr GP Lakraj  
Ms Esther Liyanage  
Dr Mrs LS Liyanage  
Dr Indika Liyanage  
Dr Sanka Liyanage  
Ms DD Lokuge  
Prof Rohan Lucas  
Mr Pasan Maduranga  
Brig (Dr) PTR Makuloluwa  
Dr Lasanthi Malaviarachchi  
Dr Sarath Malawipathirana  
Dr Kritsada Mamat  
Mr KP Manuranga  
Dr MKDL Meegoda  
Ms WDH Mel  
Dr Thushini Mendis  
Snr Prof Susirith Mendis  
Ms Samantha Menike  
Dr TP Miyanwala  
Dr Nasmia Mubarak  
Ms NKK Mudalige  
Dr IUK Mudalige  
Dr Dulini Mudunkouwa  
Dr Janake Munasinghe  
Ms MRIK Munasinghe  
Mrs Priyanga Munidasa  
Dr Dilini Nakkawita  
Dr Chandrika M Nanayakkara  
Dr Vauna Navarathna  
Mr SC Padmakumara  
Dr HR Pasindu  
Snr Prof RN Pathirana  
LCdr KGC Pathmal  
Mrs WPJ Pamarathne  
Dr Janaka Perera  
Dr Loshaka Perera  
Dr Ranjan Perera  
Mr CJSAH Perera  
Eng Randika Perera  
Ms GAD Perera  
Ms ADP Perera  
Dr Namal Perera  
Ms DR Perera  
Dr KS Perera  
Dr PKDD Pitigala  
Mr ALI Prasanna  
Dr Wuditha Premadasa  
Dr Prasanna Premadasa  
Dr GAS Premakumara  
Dr HL Premarathna  
Archt MLNH Premarathne  
Dr WMAGHA Premarathne  
Mr JMW Premarathne  
Dr S Premaratne  
Lt Col (Dr) Prasad H Premaratne  
Dr DSP Palleperuma  
Dr Malinda Punchimudiyanse  
Dr KSR Pushpakumara  
Dr US Rahubadda  
Mrs RMNP Rajapakse

Ms Prasadi Rajapaksha  
Dr UG Rajapaksha  
Dr Prabath Ranasinghe  
Snr Plnr CP Ranawaka  
Ms RBWMH Rathnamalala  
Dr Vishaka Rathnamalala  
Dr Sarath Rathnayaka  
Dr RMKT Rathnayaka  
Maj RMRKK Rathnayake  
Dr RMKT Rathnayake  
Maj RMM Pradeep  
Dr (Mrs) KKNP Rathnayake  
Dr (Mrs) RMCLK Rathnayake  
Dr AJIS Rathnayake  
Dr Saman Renuka  
Dr Thusitha Rodrigo  
Dr GD Ishani Rodrigo  
Dr Nilan Rodrigo  
Dr HSR Rosairo  
Dr AR Rupasinghe  
Dr Methsiri Samarakoon  
Mrs PWGDP Samarasekara  
Mr Rangajeewa Samarathunga  
Mrs W Samaraweera  
Dr Thisara Samarawickrema  
Ms KUJ Sandamali  
Dr MS Sandanayake  
Ms Niruka Sanjeewani  
Ms NA Sanjeewani  
Mr S Satheesmohan  
Dr G Senanayake  
Dr SP Senanayake  
Dr Asela Senanayake  
Ms Bhagya Senaratne  
Dr Thamarasi Senaratne  
Mr Asantha Senavirathna  
Dr Niroshan Senevirathna  
Ms SMKS Senevirathne  
Dr DMKN Seneviratna  
Snr Prof SRDA Seneviratne  
Snr Prof Rizvi Sheriff  
Mr ARN Silva  
Dr Sanjeewani Silva  
Dr (Mrs) RMNT Sirisoma  
Mr MA Siriwardhene  
Mrs Tina Solomons  
Dr KA Sriyani  
Ms RDUP Sugathapala  
Prof Athula Sumathipala  
Dr S M T D Sundarapperuma  
Mrs Wasana Uduwela  
Mrs DU Vidanagama  
Dr HR Vidanage  
Dr R Vijitha  
Dr Meththika Vithanage  
Mr WADGI Wanasinghe  
Dr SSP Warnakulasuriya  
Snr Prof Narada Warnasuriya  
Mrs ID Wattuhewa  
Mrs N Wedasinghe  
Dr BS Weerakoon  
Snr Prof TR Weerasooriya  
Prof DBM Wickramaratne  
Dr Wasantha Wickramasinghe  
Dr Thiwanka Wickramasooriya  
Dr Ranga Wickremarachchi

Sqn Ldr (Rtd) Uditha Wicramarathna  
Mr RD Widanagamage  
Dr Sanika Wijesekara  
Mr WLPK Wijesinghe  
Dr Namal Wijesinghe  
Ms MPC Wijesooriya  
Mrs AI Wijethunga  
Mrs MTN Wijetunge  
Ms L Willarachchi  
Dr Trilicia Withanawasam



## Session Coordinators

Defence and Strategic Studies	Brig RGU Rajapaksha RSP psc Col ULJS Perera RSP USP psc Maj RMS Rathnayake RSP Maj TVN de Saa RSP psc Ms Niruka Sanjeewani
Medicine	Gp Cpt (Dr) RANK Wijesinghe Dr KSR Pushpakumara Dr TI Withanawasam Dr BCIJ Nanayakkara
Engineering	Capt (Rtd) Eng SU Dampage Dr WTS Rodrigo Mr SD Karunarathna Capt SAAAK Athukorala
Management, Social Sciences and Humanities	Mr WAAK Amaratunga Ms HMAGK Ekanayake Ms P Lankeshwara Ms T Kotelawala
Law	Mr WS Wijesinghe Ms MRIK Munasinghe Ms AA Edirisinghe
Allied Health Sciences	Dr DU Kottahachchi Dr SP Senanayake Mr ARN Silva Ms UDH Kanchana
Built Environment and Spatial Sciences	Dr AR Rupasinghe Ms KS Dinusha Ms NDI Vithana Mr HDS Asoka
Computing	Cmde JU Gunaseela USP psc Ms WPJ Pamarathne Mr DMR Kulasekara Mr GIF de Silva
Basic and Applied Sciences	Dr SHNP Gunawickrama

## Table of Contents

<b>Welcome Address .....</b>	<b>1</b>
Major General Milinda Peiris RWP RSP USP ndc psc	
<b>Chief Guest Speech.....</b>	<b>3</b>
Prof. GL Peiris	
<b>Keynote Speech.....</b>	<b>8</b>
Prof. Kapila Perera	
<b>Vote of Thanks.....</b>	<b>12</b>
Dr. L Pradeep Kalansooriya	
<b>Factors Effect to the Post ERP Implementation in Sri Lankan Apparel Industry.....</b>	<b>15</b>
BHD Perera and SLA Munasinghe	
<b>Clustering Crimes Related Twitter Posts using WordNet and Agglomerative Algorithm .....</b>	<b>24</b>
S.P.C.W Sandagiri, B.T.G.S Kumara, K. Banujan	
<b>SherLock: A CNN, RNN-LSTM Based Mobile Platform for Fact-Checking on Social Media .....</b>	<b>31</b>
MDPP Goonathilake, PPNV Kumara	
<b>Ontology-Driven Decision Making for Subfertility of Female .....</b>	<b>42</b>
Y Thenuka, S Vasanthapriyan, K Banujan	
<b>A Mix Model approach for identifying occupational stress among the Information Technology employees: A Case Study .....</b>	<b>49</b>
M.M.K.R.I.E.Senavirathne, and R. M. Kapila Tharanga Rathnayaka	
<b>Air Quality Predicting System for Colombo City using Machine Learning Approaches .....</b>	<b>60</b>
MDCM Wijethunga, WMKS Ilmini	
<b>Real-time Animal Detection and Prevention System for Crop Fields .....</b>	<b>70</b>
R Lathesparan, A Sharanjah, R Thushanth, S Kenurshan, MNM Nifras, and WU Wickramaarachi	
<b>Diabetes Prediction System using Machine Learning.....</b>	<b>79</b>
TK Thenabadu and WMKS Ilmini	
<b>Finger spelled Sign Language Translator for Deaf and Speech Impaired People in Srilanka using Convolutional Neural Network.</b>	<b>87</b>
HKK Perera, DMR Kulasekara, Asela Gunasekara	

<b>Automated Generation of Sinhala Lyrics using Recurrent Neural Networks .....</b>	<b>96</b>
Sheng Kao and Kalani Ilmini	
<b>A software based solution to estimate the angles of incidence of AK bullets using bullet hole features on 1mm sheet metal .....</b>	<b>107</b>
Major Bandula Nishshanka, Dr Chris Shepherd and Major Randika Ariyaratna	
<b>Disease Identification in Leafy Vegetables Using Transfer Learning .....</b>	<b>114</b>
JAA Hansika and WMKS Illmini	
<b>Plant Recognition System based on Leaf Images: A Systematic Literature Review .....</b>	<b>122</b>
S Donesh, and UA Piumi Ishanka	
<b>CNN based image detection system for elephant directions to reduce human-elephant conflict.....</b>	<b>128</b>
K.S.P.Premarathna, and R.M.K.T. Rathnayaka	
<b>Computer Vision Based Approach for Traffic Violation Detection</b>	<b>136</b>
Akila Peiris, EATA Edirisuriya, CD Athuraliya, Isuru Jayasooriya	
<b>Projection Profiling Based Sinhala Braille Character Recognition and Conversion .....</b>	<b>140</b>
Major W Randika Ariyaratna, Lieutenant Colonel L Rasika Kahandagamage (Retd) RSP and MajorWMP Wasantha Kumara (Retd)	
<b>Real-Time Traffic Controlling Through Multi-Agent Technology..</b>	<b>146</b>
RT Wakkumbura, B Hettige, EATA Edirisooriya	
<b>Domain-Based Similarity Calculation Method for Calculating Document Similarity.....</b>	<b>155</b>
HMLG Herath and BTGS Kumara	
<b>Thematic Relations Based QA Generator for Sinhala .....</b>	<b>163</b>
T Dissanayake and B Hettige	
<b>E-commerce model for Visually Impaired Entrepreneurs .....</b>	<b>172</b>
HN Amaratunge, and Wijendra Gunathilake	
<b>eRemote: A Remote File Downloader for Low-Speed Network .....</b>	<b>179</b>
HMGKC Bandara and B Hettige	
<b>The Internet of Things for Health Care: A Comprehensive Survey for State-of-the-art Architecture.....</b>	<b>188</b>
APL Madushanka, U Dissanayake, KPMI Ramanayake, SMKH Hemali and RPS Kathriarachchi	



<b>Optimum Shirt Design Prediction Tool for Apparel Industry .....</b>	<b>203</b>
KPMK Leelarithne and HRWP Gunathilake	
<b>Development of Automated Aquatic Taxi for Sri Lanka using Kansei Engineering Concept.....</b>	<b>213</b>
A Kalhari, N Wickramarathna, L Yapa, D Nandasena and LP Kalansooriya	
<b>The Future Directions of the Learning Management System: A Review .....</b>	<b>222</b>
JMHK Jayalath, WAN Malshani, PBD Ariyaratna, NGC Ranahansani and WAAM Wanniarachchi	
<b>Adaptive, Interactive and Distributed E-Learning portal with Resume and Asynchronous Learning Features for Colombo Stock Exchange.....</b>	<b>231</b>
VSS Nanayakkara and WAAM Wanniarachchi	
<b>E-Performance Management Process for Athletics in Sri Lanka ....</b>	<b>242</b>
PKCD Pallewatte and DU Vidanagama	
<b>Introducing E-Farmer Management System for Dedicated Economic Centres in Sri Lanka to Reengineer the Current Marketing Process .....</b>	<b>249</b>
KPP Sandareka and N Wedasinghe	
<b>Intensive Care Unit (ICU) Management System for Dengue Ward</b>	<b>258</b>
WMCDK Weerakoon, MMK Rowel, EMUWKM Abeyrathne, MDC Gunathilake, MR Kurukulasuriya and PPNV Kumara	
<b>Improving Web Service Recommendation using Clustering and Model-Based Methods.....</b>	<b>266</b>
LRMAM Weerasinghe and RAHM Rupasingha	
<b>A Systematic Review and Comparative Study of Electronic Medical Record (EMR) Systems to Support Healthcare .....</b>	<b>275</b>
TA Gamage, WNS Dabarera, KKH Nethmini, GAI Uwanthika, LP Kalansooriya and B Wijay	
<b>Lawyers' Work Management Through Digitization.....</b>	<b>284</b>
MVT Kawya and N Wedasinghe	
<b>An Analysis of Applying Software Development Methodologies in Military Software Development.....</b>	<b>293</b>
LM Wijethungaarachchi and SPIU Dayarathna	
<b>Web-Based Workload Maintain System for Midwives in Sri Lanka .....</b>	<b>305</b>
DWGML Dissanayake, DU Vidanagama and N Wedasinghe	

<b>A Review of Blockchain Consensus Mechanisms: State of the Art and Performance Measures.....</b>	<b>315</b>
Thanushya Thanujan, R. A. C. P. Rajapakse, and Dilani Wickramaarachchi	
<b>Social media sentiment analysis for customer purchasing behavior – A systematic literature review .....</b>	<b>327</b>
M.A.L Manthirathna, W.M.H.G.T.C.K. Weerakoon, R.M.K.T. Rathnayaka	
<b>An Alternative Approach to Authenticate Subflows of Multipath Transmission Control Protocol using an Application Level Key ....</b>	<b>336</b>
Tharindu Wijethilake, Kasun Gunawardana, Chamath Keppitiyagama and Kasun de Zoyza	
<b>An Ontology-Based Data Mining Approach for Predicting the Research Ideas using Past Research in the Wildlife Sector of Sri Lanka.....</b>	<b>345</b>
P Premisha, BTGS Kumara, EP Kudavidanage, and K Banujan	
<b>Citizens Acceptance of Online Services in Sri Lanka Police: Study on Police Clearance Online System .....</b>	<b>352</b>
HANK Damayantha Wijaya Sri	
<b>Recursive Image Segmentation for Vehicular Traffic Analysis.....</b>	<b>363</b>
Manusha Eeshwara, Rohana Thilakumara, Niranga Amarasingha	
<b>“TrainGo App” - Mobile based Train Ticketing System for Railway Department in Sri Lanka.....</b>	<b>369</b>
A. D. Supun Nimesh, Samanthi Wickramasinghe, Sunesh Hettiarachchi	
<b>Journal or Book? : The HydroGIS Perspective on Engineering and Computing Debate .....</b>	<b>377</b>
RMM Pradeep, NTS Wijesekera	
<b>Use of Security Culture to Contribute on Enterprise Information Security for the Small and Medium Scale Enterprises (SMEs) .....</b>	<b>387</b>
HPAI Pathirana	
<b>IoT based Health Monitoring and Activity Detection for Elderly Care .....</b>	<b>396</b>
Nethshan Narasinghe, RPS Kathriarachchi, and M.W.P Maduranga	
<b>Analyzing the Influence of Various Factors for Vegetable Price using Data Mining .....</b>	<b>402</b>
I.M.G.L. Illankoon, B.T.G.S. Kumara	
<b>UECS: University Eligibility Checking System for State Universities in Sri Lanka .....</b>	<b>410</b>
ABTMAS Bandaranaike, IWMHD Bandara, DA Iddamalgoda, BLA Kalhari and WPJ Premarathne	

<b>IMAGIBOT – An Image Recognition Chatbot for Sri Lankan Ancient Places .....</b>	<b>418</b>
P J Senevirathne and D U Vidanagama	
<b>Survey on Deep learning based Network Intrusion Detection and Prevention Systems.....</b>	<b>427</b>
MAT Padmasiri, VVV Ganepola, RKHMSD Herath, LP Welagedara, GANS Ganepola and P Vekneswaran	
<b>ATM Detail protection using Geofence Technology.....</b>	<b>437</b>
SS Keerthiwardane, IA Wijethunga	
<b>Introducing a LSTM based Flood Forecasting Model for the Nilwala river basin with a Mobile Application – a Review .....</b>	<b>443</b>
RM Ranasinghe and WMKS Ilmini	
<b>Feasibility Study of Hologram Gamification in Sri Lankan Higher Education Distance Learning .....</b>	<b>451</b>
BMTN Rathnayake, Indika de Silva and Bhanuka Senavirathne	
<b>Web-Based Application For Mothers &amp; Midwives .....</b>	<b>459</b>
DGBC Wijayawickrama, SCM De Sirisuriya, N Wedasinghe	
<b>Smart Pest Recognition System for Sri Lankan .....</b>	<b>468</b>
<b>Crop-Growing .....</b>	<b>468</b>
LGC Theertha, and WAAM Wanniarachchi	
<b>Implement Biometric Electronic Voting System in Sri Lanka .....</b>	<b>476</b>
UP Muthukumara, RMM Pradeep	
<b>Survey on wearable sensor technologies on driver drowsiness detection.....</b>	<b>485</b>
P.D.S.T Gunathilaka and P.Kalansooria	
<b>Analysis on emotion classification methods .....</b>	<b>493</b>
IO Goonewardena and Pradeep Kalansooriya	
<b>Challenges in investigating Cybercrime in social networks: A Sri Lankan Perspective.....</b>	<b>506</b>
K. G. Laksiri Geethal, Kasun De Zoysa, Kenneth Thilakarathna, Primal Wijesekera and Chamath Keppitiyagama	
<b>A Study on the Ayurveda Plant Recognition for Remedial Medications Using Image Processing Techniques.....</b>	<b>515</b>
K. Anuradha, D.P.M. Lakshan and R.P.S. Kathriarachchi	
<b>Automate Timetable Scheduling with AI: A Review .....</b>	<b>523</b>
C L T H Gajanayake, W P J Pamarathne	

**Impact Of Traditional Supply Chain Management On Green Supply Chain Management..... 529**

HMS Ayeshi, LBL Senevirathne and WMSRB Wijerathne

**E-commerce Personalization for Local Music Instruments Market in Sri Lanka**

AMTN Adasuriy, WJ Samaraweera and WAAM Wanniarachchi

**Automated Hospital Clinic Maintaining System for Government Hospitals in Sri Lanka ..... 547**

GRM Gunarathne and IA Wijethunga

**Use of Distance Learning Technologies Efficiently in a Crisis/Pandemic Situation ..... 553**

GGA Ranasinghe, KHNK Kumarasinghe, AHMD Somasiri, RT Wehella, RPS Kathriarachchi

**Focus Assistant: Identifying the level of motivation in computer users..... 560**

THDS Sugathadasa, HL Premaratne, and LP Kalansooriya

**Sri Lankan Currency Recognition Device for Visual Impaired People ..... 568**

AAAN Athapaththu, WMSRB Wijyaratne, and DMR Kulasekara

**Monitoring mental health of Sri Lankan youngsters during COVID 19 with passive mobile sensing..... 576**

KAAB Gunarathne, KPN Jayasena

## Welcome Address

Major General Milinda Peiris RWP RSP USP ndc psc

*Vice Chancellor, General Sir John Kotelawala Defence University*

Honourable Minister of Education, Professor G L Peiris, the Chief Guest , Keynote Speaker, Secretary to the Ministry of Education, Professor Kpila Perera, Secretary to the Ministry of Foreign Affairs, Admiral Prof. Jayanath Colombage, Deputy Vice Chancellor (Def & Admin) Brig. Nanda Hathurusinghe, Deputy Vice Chancellor (Academic) Prof. Jayantha Ariyaratne, Deans of the respective Faculties, Directors of Centres, Academics, Senior Military Officers, Administrative Staff, Students and all distinguished guests who are connected with us in the cyber space.

First and foremost, let me very warmly welcome our chief guest, Hon Professor GL Peiris, Minister of Education for very kindly accepting our invitation and for gracing this occasion as the chief guest of this inaugural session of our international research conference 2020.

Sir, we consider your presence here this morning, as one of the most renowned scholars the country has ever produced in the field of Law, as a great honour to KDU. Let me also warmly welcome our keynote speaker, Prof Kapila Perera, Secretary to the Ministry of Education, who is having a very close affinity with KDU as an illustrious member of our alumni association.

Then I also welcome Admiral Professor Jayanath Colombage, Secretary to the Ministry of Foreign Affairs, and other distinguished guests and invitees participating on line as well. KDU, from its inception, was instrumental in handing down the core values of security to the development paradigm in Sri Lanka.

This year's theme 'Holistic Approach to National Growth and Security' highlights the importance of maintaining a harmonious blend in security and development in all national projects. As you are aware, this year's conference is taking place amidst very challenging circumstances, so much so that, it becomes a landmark event of KDU in terms of its resolution to ensure the continuity of events at KDU even under the most trying circumstances. And this conference is also significant because the year 2020 marks 40 years of existence of KDU since its inception in 1980.

KDU, initially established as a tri-service academy known then as KDA or Kotelawala Defence Academy, marked a significant diversion in 2008 with its renaming as General Sir John Kotelawala Defence University. Since then, with the guidance and vision of His Excellency the President Gotabaya Rajapakse, as the then Secretary to the Ministry of Defence and the Chairman of our Board of Management, KDU kept a giant leap forward to become a fully-fledged university with nine academic faculties and a University Hospital with state-of-the-art facilities. With this phenomenal change, KDU began expanding its horizon to provide its high-quality higher educational opportunities to civilian students, thereby reducing the burden on other state universities of the country in supplying for the higher educational demand in the country. Today, the University is ready to march forward steadfastly contributing to the national needs combining the national security domain with higher educational needs of the country.



Ladies and gentlemen, KDU international research conference has been attracting local and foreign presenters, participants and more importantly renowned scholars and professionals of the highest caliber both locally and internationally. However, in this year, the global pandemic situation has restricted having them physically present at KDU. But many of our invitees will join us on line to enrich the deliberations through this novel experience of having the conference on a virtual platform.

I reckon that this is a blessing in disguise for us to travel on untrodden paths for new discoveries. KDU IRC has been instrumental in establishing and strengthening the much needed research culture not only at KDU but also in the whole country.

We have been attracting papers from almost all universities, from many research institutions and other organizations representing even Batticaloa and Jaffna, which I reckon is a very encouraging sign. And the impact of the growing research culture was evident during the first breakout of Covid 19 earlier this year, where our staff and students were researching day and night for creating various products and inventions of our own to help the fight against Corona. So, it is heartening to note that in this year's conference, there are many research papers reaching the conference secretariat, which involve the student community of our nine faculties.

Therefore, we are proud that we have created a platform for emerging researchers and scientists for showcasing their research outcomes at KDU research conference. And it is our fervent belief that inculcating and fostering the research culture and enhancing the quality and quantity of research in various disciplines in the country can raise the resilience levels of society and the nation as a whole.

This year's conference has attracted six hundred and fifty plus paper submissions, which I believe is a very clear indication of the right enthusiasm growing in the country towards research, particularly in development and security domains. So we are proud as a university to be able to stand up resolutely to fulfill the needs of the nation, especially at a time when such efforts are very much needed. I believe the efforts of security-based education aiming at strengthening national development should be more cooperative in the future and KDU has always facilitated any research efforts that strengthens the national security of our nation. We urge the academic community of Sri Lanka to join hands with us in all our future endeavours to support the nation especially through productive research in diverse disciplines.

The organizers of the KDU international research conference intend to set the tone to initiate more collaborative research at national and global levels. This research conference is an ideal platform to make connections. I hope that authors of KDU and various other local and international universities will take the opportunity to interact and develop friendly relationships, establish networks and to explore win-win situations.

I wish all the very best for the presenters and hope you will enjoy every moment of this academic fusion taking place on two whole days.

Finally, let me once again welcome our chief guest and the keynote speaker on behalf of all KDU staff. I wish that presenters and participants would have all the courage to continue their pursuits with determination to link up with the international community and work towards national growth and development through their research.

Thank you.

## Chief Guest Speech

Prof. GL Peiris

*Honourable Minister of Education, Government of Sri Lanka*

Major General Milinda Peiris, Vice Chancellor of the Sir John Kotelawala Defence University of Sri Lanka, Admiral Professor Jayanath Colombage, Secretary to the Ministry of Foreign Affairs, Professor Kapila Perera, Secretary to the Ministry of Education, Deputy Vice Chancellors, Deans of Faculties, Heads of Department, members of the staff and students of this university, friends well wishers, ladies and gentlemen. I am delighted to be present with you on this occasion for the 13th International Research Conference. I am no stranger to these surroundings. I have been consistently associated with your work during the progress of your university until you have reached the stature that we all are proud of at this time. There is no doubt that with the nine fully-fledged faculties that you already have and your plans further to expand this university particularly bearing in mind the priorities of this country at this moment. I am particularly happy about your plans for the establishment of a Faculty of Criminal Justice. I think that is certainly an area that is worthy of focus and attention. So you have always assessed, evaluated very accurately the needs and priorities of our country in the field of Higher Education. And you have been very quick to respond to those needs. That innovative approach is much to be admired. And these are among the reasons why I have particular pleasure in joining you in these deliberations. There is one another matter that I would like to mention. It is this that you are having this conference for the 13th consecutive time. It is our experience in this country that many good things are planned and inaugurated. It is much more difficult to follow through. So the fact that you have been able to do this without interruptions for 13 years adding to your

expertise as you go along improving and expanding towards what you are attempting. It is greatly to be admired the sense of perseverance and determination that is greatly required in this country at this moment and your performance is an inspiring example of what we all need to carry the country forward to even greater heights.

Now the theme that you have chosen for this 13th International Conference is extremely appropriate from many points of view. You have heard representation from many countries as Major General Milinda Peiris, Vice Chancellor explained a moment ago. You are holding this conference in exceedingly challenging circumstances. Again you have been to adapt to difficult circumstances. You are resorting to modern technology to include and involve foreign participants in these deliberations even though they are unable to present with us physically on this occasion. The topic that you have chosen is the holistic approach to national growth and security. I think that is extremely relevant to present day needs in Sri Lanka today.

The first point I would like to make is that there is an intimate connection between national growth and security. It is fanciful to talk of any kind of national growth without the assurance of security. Security is a necessary and indispensable foundation. Without security it is impossible to achieve growth in any sector of the economy. The celebrated Political Scientist the late Professor Harold Laski of the London School of Economics said that the basic duty of a state is to provide security for its people. That is the ultimate reason for the existence of the nation state. The theory of the Social

Contract which has been developed by writers like Lock and Rousseau emphasizes the fact that the public have given the authority to state principally for the reason to create conditions in which life can go on in an orderly and frank manner so that the citizens of that state can realize their fullest potential as human beings, develop themselves and develop the community in which they live. In order to do this the essential condition is security. Without it nothing at all can be accomplished. Now we have seen empirical evidence of this in the recent past of our country through the 30-year conflict with the Liberation Tigers of Tamil Eelam. It was impossible to attract substantial investment into this country. Every facet of Sri Lanka's economy suffered grievously during that period. How can you attract investors into a country which has been thrown asunder by a ferocious war? Investment, international trade all this was affected by the ongoing conflict. I would also like to make a reference to the concept of reconciliation which became very relevant and important after the end of the war in 2009. There was then naturally the feeling that we have to leave the pain and anguish of the war behind us. We have to emphasize unity and the solidarity and bring together all the people of our cherished land irrespective of caste, creed, ethnic or religious identity to emphasize the oneness of the nation. That was the pith and substance of the concept of reconciliation. But it all went wrong during the *Yahapalana* administration of 2015 to 2019. And it is worth examining in an objective spirit the reasons why that endeavour failed so miserably. I think the basic reason is that the authorities at that time forgot the sentiments, the feelings and aspirations of the majority community. Reconciliation of course bases emphasis on minority aspirations to make them comfortable, to convey to them in definite terms the impression, the conviction that they are very much part of the country. They

belong, the sense of belonging so that confidence should be imparted to minorities, and at the same time, it is absolutely necessary to carry the majority community with you. If you lead them behind if you engender in the lines of the majority community that they are not important, they can be sidelined, they do not matter, such an exercise in reconciliation is doomed to failure as empirical experience in those 4 years convincingly demonstrated. What happened during that period? I think the most alarming spectacle that we are seeing in this country today is evidence that is transpiring in daily basis before the Presidential Commission that is going into the catastrophic phenomenon of the Easter Sunday Attack. Evidence has been given by one witness after another, the Inspector General of Police, the Secretary to President, the Secretary of Defence, all these people. Their evidence emphasizes the total breakdown of this security apparatus in the country. It is not mere debilitation or weakening of security apparatus it was total collapse of it. There was no security apparatus functioning in this country at all in any realistic sense. So it led to the loss of 265 valuable lives of this country and crippling of many other citizens of our land. Why did this happen?

When the present President, His Excellency Gotabaya Rajapaksa was Secretary to the Ministry of Defense, there was a very close collaboration between the intelligence arm and immigration. Whenever an application was made by a foreign preacher somebody who wants to come and teach in this country, when visa was requested a very thorough background check was done. As Admiral Professor Jayanath Colombage would bear witness the antecedent of the person applying for the visa was thoroughly examined. And if there was anything unsavory in the past of that person, if he has been involved in any activity which led to

disharmony among communities, then the immigration authority in close consultation with the intelligence arm would turn down such a request for visa in this country. That whole apparatus was consciously and deliberately dismantled. It did not happen unwittingly or inadvertently. It was deliberate government policy. So intelligence personnel were made to feel that they were in embarrassment. The less that heard from them, the less they were seen the better. That was the environment which prevailed at that time.

Surely, if you are talking of national growth and security, the first thing to ensure is that funds that are coming from abroad had to be brought into the country through proper channels. We have in this country such an established conduit. The conduit is the External Resources Department of the Central Bank of Sri Lanka. Of course resources are welcome. But they must come through the External Resources Department. We must know the source, the origin of these funds and where are these funds coming from? We must know the purpose for which these resources are going to be applied, who is going to manage these resources? There must be an auditor accounts. All of these were dispensed. You had a situation where a university was built. What is the purpose for a university to come up in Kattankudy. The facilities, the buildings that are constructed, they are better than the buildings that you have here at the Kotelawala Defence University. They are superior to the quality of the infrastructure in the universities of Colombo and Peradeniya. If you go to Kattankudy blindfolded if the blindfold is taken off when you get there, you will feel that you were in the Middle East. The Palmyra trees, the architecture the overall environment. The sums of money involved are colossal. There is no exposure, visibility or accountability. It is that brought about a situation that culminated in the total collapse

of this security establishment. Madrasas can be all over the country. There are no Sunday Schools. They are providing many of them on daily basis. Nobody examines the curricula. There is no regulatory mechanism at all. So the seeds of racial hatred are sown by those institutions. Of course there must be freedom with regard to imparting instruction. But clearly there must be some supervision, some control, some regulation. That was totally lacking. So the country then paid the supreme price for the neglect of security in pursuit of narrow and partient and political objectives to placate aggressive minorities, not law abiding members of minority communities, but people who were intent on the destruction of the very social fabric of the country. So that was our sad experience.

This is true not only within the country, but also in the conduct of our foreign relations. What happened there? Sri Lanka is unique among the nations of this world in committing to a resolution in 2015 in the UN Human Rights Council. Sri Lanka became a co-sponsor of a resolution in condemning its own armed forces accusing its armed forces of the gravest crimes under international law and under the international humanitarian law because the preamble to resolution 13/1 of the 1st of September 2015 acknowledged with appreciation the report of the High Commissioner for Human Rights. And the High Commissioner's report makes the most damaging allegations against the armed forces of this country. And the government of Sri Lanka endorsed all of them and called for a thorough investigation at the international level. The resolution gave responsibility to the Human Rights Council and to the Commissioner for Human Rights to keep Sri Lanka under constant review. So here was a government which consciously, voluntarily, deliberately submitted the country to adjudication and assessment in respect of its armed forces to international tribunals

where justice considered the inanity of what happened. There were pledges given. In resolution 13/1 and 34/1 which are clearly contrary to the highest law of this country, the constitution of Sri Lanka operating para 6 of the first resolution 13/1 recommended that foreign judges of Commonwealth and other foreign judges should be entrusted with the task of judging our armed forces and of course, members of the civilian population. This is not possible under Sri Lanka's constitution because foreigners cannot exercise judicial power in respect of our citizens. And then the High Commissioner for Human Rights, Prince Hussein publicly conceded that in respect no other country has a Human Rights Council based in Geneva adopted so intrusive approach – so intrusive, interfering directly with domestic policy in that country. To what extent did this go? The resolutions involved matters which are clearly within the domain of the Sri Lanka's parliament not the business of foreigners. It called for constitutional reform. It called for devolution of greater powers to provincial councils. It called for thorough overhaul of Sri Lanka's armed forces and the police. It called for the repeal of the prevention of terrorism Act and its replacement by alternative legislation. Members of the Sri Lankan armed forces and the Sri Lankan police force were to be subjected to special criteria when they applied to join UN Peacekeeping forces abroad and even to enroll for programmes of training. So this is the extent to which national dignity and pride was compromised in order to placate foreign interests whose aims and objectives were incompatible with the well-being of this nation.

So this attitude which destroyed the very foundations of our national security manifested itself both in respect to domestic policy and the conduct of country's foreign relations during that period 2015 to 2019. In such a situation you cannot possibly have

national growth. You cannot have economic advancement because security has broken down entirely.

Just one another point I want to make before I conclude, and that is the reference to militarization in the current political discourse. Non-governmental organizations and elements of the opposition as well as some prejudiced and biased foreign commentators are finding fault with the role of the military in the conduct of national affairs in Sri Lanka at this time. But no objective observer of the Sri Lankan scene can doubt the fact. When it came to the control of COVID-19, this country could not possibly have achieved what it did without the vigorous involvement and cooperation of the armed forces, particularly the intelligence arm. We were able to control the pandemic because the armed forces were able to identify those who have been infected, first the immediate circle and then the outer periphery. That is still being done, yesterday today it is being done. And the role of the armed forces is indispensable. Without them the situation would be far worse than it is. Why is there this kind of hostile attitude towards armed forces? I think people who subscribe to that point of view failed to distinguish between the culture of east and west in this regard. Cultural attitudes, assumptions and values are in critical significance in this area. The attitude in this country, the attitude of the public, of ordinary people, to the armed forces is not what prevails in some western countries. The armed forces are not looked upon with fear. They are not regarded as instruments of oppression. On the contrary, after the war ended in 2009, it is in effect the armed forces, they got involved very intimately, very vigorously in uplifting the social conditions in the people affected in areas. They built houses. They made water available. They played a role in restoration of agriculture. And I know personally because I have seen in

my own eyes that armed forces of this country even helped in the constructions of latrines, of toilets in that part of the country. These are not regular functions of the armed forces. But because of the culture of our country the social morals the value system based upon empathy and compassion which is the hallmark of Sri Lanka's culture. That was the nature of the role that was performed by the Sri Lankan military. It is this fundamental fact that is not taken into account. In critiques of the present scene who find fault with the armed forces forget their involvement in national activity on broader scale.

So these are some of the remarks that I would like to make to you on this occasion. I am very happy that you are having this 13<sup>th</sup> International Research Conference. I am very happy that you have chosen a topic that is extremely appropriate. You have chosen a more relevant topic for this time. As the Minister of Education also with the responsibility for higher education in this country, I am very proud of the achievements of your institution, what you have been able to accomplish within so brief a time span. The needs of higher education in this country are very urgent when more people are clamouring for access to higher education, in our ministry, with the active system of Professor Kapila Perera who is rendering a yeoman service in that regard, we are trying to bridge the gap between education and employment opportunity. We are talking to the major Chambers of Commerce they provide the jobs in the private sector to ascertain from them the employment opportunities that will be available in their institutions during next three or four years, what are the skills which we are looking for? Because they are telling me it is not that we

do not have jobs to offer. We have jobs. But when we interview people we find that they don't have the skills which we want in our institutions. So we don't want to enhance a reservoir of angry and frustrated young people. We want to ensure that there is a correlation between the education that is imparted in our institutions and the skills for which there is an identifiable demand in the market place. So these are some of the adventures that we have embarked upon. We are also looking critically at our curricula which are obsolete and anachronistic. They have not been revisited for a very long period. There must be in line with the needs of our society methods of teaching. There is far too much emphasis on rote learning in memory that students have required to commit their notes to memory, retain in the memory and reproduce it at the examination that is antithetic of the education. Education comes from Latin words '*educate*' which is draw out not to force in vast volume of actual material into mind of the students. So purpose of the education is to develop the analytical and the critical faculty of the student to encourage him or her to think for himself or herself and apply that volume of knowledge to face the challenges of life. So in the midst of all of this, in confronting the formidable challenges, I am very confident that your institution, Sir John Kotelawala Defence University will render an invaluable service. So I congratulate to you on your achievements of the past and I wish you well for the future. I know that you will continue to do your country proud. And I thank you sincerely for the honour that you have bestowed upon me by inviting me as the Chief Guest for these deliberations.

Thank you

## Keynote Speech

Prof. Kapila Perera

*Secretary, Ministry of Education, Government of Sri Lanka*

Ayubowan! Wanakkam! Assalamu Alaikum! The Vice Chancellor of General Sir John Kotelawala Defence University, Major General Milinda Peiris, the Chief Guest today my honorable Minister, Ministry of Education, honorable Professor G.L. Peiris, Deputy Vice Chancellors, Deans of the Faculties, Heads of the departments, the Secretary to the Ministry of Foreign Affairs, Professor Admiral Jayanath Colombage, all the foreign participants who are joining this 13th International Research Conference at KDU, all the presenters, moderators, session chairs and all the distinguished invitees. Thank you very much for inviting me to deliver the Keynote Speech under the theme 'Holistic Approach to National Growth and Security.' I am indeed honored and privileged to be here having witnessed the very first one 13 years ago, and it happened to be General Milinda Peiris who was the Vice Chancellor then as Major General and we witnessed the presence of the Chief Guest as the Ministry of Higher Education, Ministry of Research and Technology.

I would like to start with this quote from the Chief Guest, "We do not want to have a reservoir of angry uncontented people." I was one who had gone through in 1971, of course not in the country in 1988 -1989 and then in then 1983 as a university student, and many times during my academic career where there were disruptions to education, holding back the desire to fulfill or acquire knowledge with my colleagues, peers and the rest of the people due to the lack of security. I know how I felt then as a student. I think I was in grade 4 in 1971, and then in 1983 in my second year at this very same premises, the education of ours were disrupted. And

the feeling of those delays due to the lack of security, and the Cheif Guest elaborated in deep sense of comprehension how security is important for the national growth. If I look at what is this traditional approach that is often based on defensive security policies as we had during my time at different ages. We had always defensive security policies. However, the persistence of strong security measures generates incure feelings. I hope you agree with me. If there are strong security measures that generate insecure feeling as it reveals the presence of threats. So these are some of the things that people quote. Then again the democracy, well-being and freedom are some of the elements that we feel that we reduce this feeling of insecurity by reducing both threats and activities that we feel. Even if you take a house if you feel this insecureness due to lack of security this might not allow you to think, generate analytical skills. You are always worried about the security. How to provide security to your children and for yourself? And then it hinders and it slows down entire process of nurturing, acquiring knowledge. And then that it is halting the growth. so you start from the small households or individuals then if you take as a whole family, a village, a township and then provinces as a country, it basically retards the national growth. So, therefore, we need to have this thinking of holistic approach to national growth and as you and I understand there are necessary and essential conditions when we learn mathematics for certain things. The Cheif Guest emphasized repeatedly the essential elements and in our academic mathematics there are sufficient and necessary conditions or essential conditions for forming mathematical theories there are certain

things. Likewise, it is essential to have security for national growth.

When it comes to economics, always and even for decades, the GDP strongly criticizes the measure of development. Still the role of economic systems neglecting the goal of global capabilities and expansion holds this economic growth or national growth. But the concession of development based on the glorification of individual success and the pushed capital accumulation hardly allows reducing insecurity and increasing freedom. So security becomes an individual good and relies upon ineffective defensive policies that we have practiced in the past unlike in the present. So development, well-being, security and freedom are strictly interrelated. Individual capabilities imply collective capabilities. Even in free market economies often human needs such as food, housing, employment, health care, family policies, fresh water, security and safety can be put in a market under regulation or collective governance, and those things even the Chief Guest highlighted. The need for water, need for food, how the security-- food security and water security ensure the getting this national security when you combine all these types of security the national growth under war conditions. So these goods are often under political debate as they are critical for development and social cohesion. The more they are shared among the large part of the population the less we experience social conflict and political instability. Security hardly is achievable individually. It is the result of more holistic thinking. Individual security and freedom implies the security and freedom of all. As I mentioned before these are interrelated. And if you look at or if you study research and in future research all these studies can help in understanding human capabilities and pathways towards collective security and enhance development. So instances of participation in

definition of security needs would make citizens able to feel at the center of development goals. So therefore, unlike in the past where we did not think holistically and the interrelations between the security and the national growth. Then we will fail. Even the theories in the literature highlights this one.

As far as Sri Lanka is concerned the contemporary security concerns that we face as an Indian Ocean country are broader and more complex, that need not be elaborated, than any state in our history. This will continue to exist. We can't say that this will stop today, tomorrow, next year or in ten years' time because the geopolitics and the race for the arms business and economic development, all these things will continue to grow, sometimes exponentially. So therefore, national security cannot be neglected and cannot be just let it go as the Chief Guest mentioned, even in a fraction of a second, it is very important. Otherwise there won't be any growth. As the Secretary to the Education, in the present context the role played by ensuring a secure environment for the student to go and sit the examination. They are not in a position to concentrate on answering the questions if the place is not secure. So if we are not able to hold the exams and continue to postpone, then we cannot achieve and we cannot predict national growth. So in this context the role played by the national security is to be commended as the Ministry of Education. I know personally the quick response to ensure secure examination centers for all of us for the future of Sri Lanka. Under these conditions even the identification of COVID origin in the recent past, you have to have peace of mind to concentrate on everything. That is basically if you only think of one place, one center out of 2,646 examination centers, then there will be lack of security in different centers. So therefore, you have to think holistically. Only the one aspect of securing



one place will not enable for us to continue this one and therefore the results will come in future in terms of national growth. So the range that concerns arise from threats to system that allows society to control intergroup and interpersonal conflict to more recently reorganized concerns associated with threats to social and economic systems. Once these events start to influence the policy and the economy of a country with a national resilience, that country will perish. One way of addressing this emerging situation is by promoting more and more research and development.

KDU, boasting with diverse nine faculties and through two new faculties to come, the Faculty of Criminal Law and the Faculty of Technology, is going to expand and provide opportunities and platforms for you to think, ponder in a military environment and inviting day-scholars giving the signal that is very important for you to mix each other understand the role of the military or security for the civilians, 22 million people in this country, how important the national security and the training in a military set up to achieve the common goal of national growth. So the KDU is at the forefront of researching the development and security related problems holistically. A holistic approach is needed to understand contemporary complex situations and circumstances. University education could inculcate co-values of security and development such as human dignity, integrity, democratic participation, sustainable development, economic equity, mutual understanding and respect and equality of opportunity. The three flags that are behind bring all three forces together, thanks to the KDA then, and how important this mutual understanding in the war was understood and it helped to coordinate things in a better manner. You trained officer cadets together and they understand the security roles in the air, at sea, on land. I am

sure that it could have been the catalyst then. Now you bring the third aspect the day-scholars. So this is holistic thinking. Like I started at the beginning it was not there then. We had three academies that did not know each other, but how had it come during the time when the national security was at risk. So ultimately the beneficiary is national growth. The honorable Minister, the Cheif Guest mentioned how difficult it was for Sri Lanka to attract foreign direct investments. As I think Minister of Enterprise Development, Foreign Minister, Foreign Secretary. If you don't have security and thrust, nobody would come. But when you train together military and civilians with hand and hand, it would provide an ideal platform. The importance of civil-military relations and how KDU is instrumental in developing the above mentioned areas is to be commended. By promoting civil-military relations through education, a country could raise the resilience levels, like I mentioned, of communities. Honorable Minister spoke at length and elaborated that you have to have a strong commitment and the political will to ensure the security of this country. If these elements, instruments fail, the first thing that is going to effect is the education of the future generations. Even for me, the Oxford graduate, Rohdes scholar, I am a pupil. And this has provided opportunities and the responsibility to the government to ensure the security. So all spheres of activity will simultaneously grow ultimately culminating in national growth.

These are the few thoughts that I have to share with you. I would like to extend my gratitude on behalf of the Ministry of Education for having me and inviting me to deliver the Keynote address and set the platform for the next two day deliberations. And I wish all the success in the deliberations and creating more networks and have future directions for years to come in this context of national security that you have chosen today.

Whatever that you are going to do, base national security at the forefront. So divided we lose together we win. And I wish all the very best and thank you very much for all the participants and the people who have submitted papers, presenters, moderators,

and session chairs. You are plying a very important role in this context of national security and the national growth.

Thank you very much!

## Vote of Thanks

Dr. L Pradeep Kalansooriya

*Conference Chair, 13<sup>th</sup> International Research Conference,  
General Sir John Kotelawala Defence University*

It is with deep appreciation and gratitude that I present this vote of thanks on behalf of the organizing committee of the 13<sup>th</sup> International Research Conference of the General Sir John Kotelawala Defence University.

First of all, I convey my heartiest thanks to Professor G.L. Peiris the Minister of Education, a distinguished academic who spared his valuable time with us on this occasion. Sir, your gracious presence amidst busy schedules is truly an encouragement and it certainly added the glamour and value to this important event.

Professor Kapila Perera, the Secretary to the ministry of Education, also a distinguishable academic and a senior military officer is a proud product from our own institute. Sir, I greatly appreciate your willingness without any hesitation to be our Keynote speaker today.

I would also like to take this opportunity to extend my appreciation and gratitude to the Vice Chancellor, Maj. General Milinda Peiris for all his guidance and assistance provided throughout the event and this event wouldn't have been a reality and a great success without your courageous leadership under the current challenging situation today.

I would be falling my duties if I don't mention the exceptional support and assistance provided by the two Deputy Vice Chancellors who were there behind the team guiding us through a difficult time. I also would like to thank the Deans of all the faculties who shared the responsibilities and guided their staff amidst their very busy schedules.

This year's conference has attracted six hundred and fifty plus paper submissions, which is a very clear indication of the right enthusiasm growing in the country towards research, particularly in development and security domains. I take this opportunity to thank all authors share their studies on National Growth and Security in our conference. I also greatly appreciate our panel of reviewers on the valuable time spent to review this large number of papers. I'm sure that your valuable resnses would tremendeously supports to authors on enhancing their research studies.

Ladies and Gentlemen, as you witnessed, this was a new experience in the new normal, after the present pandemic, and therefore it was huge challenge to organize, coordinate and conduct research conference of this magnitude on virtual platform enabling a wider participation of both local and foreign participants. I thank all our participants attending the conference online despite numerous difficulties encountered due to the present situation.

Further, it is with great pleasure that I acknowledge the tremendous support and assistance provided by academic staff of all the faculties with all the Heads of Departments going beyond their regular duties to make this event a success. Similarly, I take this opportunity to appreciate the contribution of the administrative and non-academic staff whose commitment was essentially required in achieving the overall success.

Our sponsors, the financial support given by our Platinum Sponsors, People's Bank and

Bank of Ceylon and Co-sponsor, Abans Private Limited is highly appreciated.

Last but not least the officer cadets and day scholars who formed a very virtual component of the organizing teams in every sphere and I believe that it was a great learning experience and exposure which would help them tremendously in similar undertakings in the future.

Finally, I have no doubt that all of those attending the two days seminar will make the best use of the opportunity to enhance their horizons and establish new bonds and networking while sharing their own knowledge and experience in a friendly learning environment.

In conclusion, let me take this opportunity to profusely thank my co secretaries, who stood alongside me throughout extending unexplainable support and assistance with exceptional commitment.

Thank you so much. I wish you good luck and all the best.

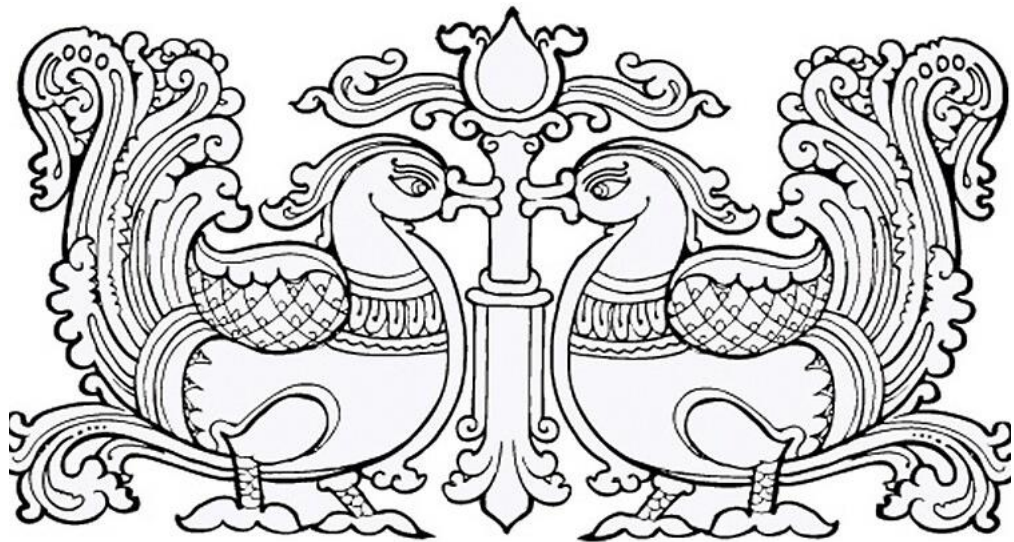

# Technical Sessions

## Factors Effect to the Post ERP Implementation in Sri Lankan Apparel Industry

BHD Perera# and SLA Munasinghe

*Department of Computational Mathematics, Faculty of Computing, General Sir John Kotelawala Defence University, Sri Lanka*

#harshanip@kdu.ac.lk

**Abstract:** An ERP system is playing a vital role in any organization to achieve the required speed, efficiency and accuracy of the daily business operations through automation and integration, providing a centralized and integrated system to increase the organization's productivity while reducing the time and labour costs. But most of the leading manufacturing organizations ended up adopting ERP systems without having the expected results. Most of the organizations failed to gain the true benefits as expected because of the lack of attention in the POST stage of the implementation. Since it takes a while to reap the full benefits, it is critical to have a successful ERP life cycle. Therefore the importance of post-implementation success factors is critical for any organization.

Similarly, garment manufacturing organizations have adopted the same trend by implementing new ERP systems by replacing their legacy systems. It seems that garment industries were successful when adopting the ERP systems than other manufacturing organization in Sri Lanka but this research would focus on to develop post-implementation success factors by analysing factors which have helped according to literature and industry knowledge and experience. Both qualitative and quantitative approach has been used to analyse the data and interviews and surveys used to capture the data in this research.

Research has shown that not only those technical issues but also some problems such as not use of effective change management, top management support, Business process reengineering, etc. Moreover, the proposed framework can be used as a guideline for

successful ERP implementation at garment manufacturing organizations.

**Keywords:** Post ERP Implementation, Multicollinearity, Stepwise Analysis, Principal Component Analysis

### Introduction

General satisfaction levels for ERP software continue to trend high. The survey conducted by Panorama's consulting received 86% satisfied with their ERP software and compared to 2012 the percentage has increased by 5%. Even though the high levels of overall satisfaction with the software only 60% respondents mentioned that their ERP implementations are successful. One third of the respondents didn't know if their project was a success. This points towards lack of post-implementation auditing, lack of business process and lack of communication about the project outcome from the top management. Furthermore 10% respondents highlighted that their ERP project was a failure.

The researches carried out by various parties proved that companies put less effort on ERP post implementation activities when compared to the pre implementation and implementation stages. Therefore companies are unable to get the much anticipated and predicted benefits from ERP implementations. Situation remains same in the Sri Lankan business environment. Most of the companies are still unable to take the full benefit out of ERP implementations. This is due to not having proper mechanism to

monitor the post implementation activities of ERP implementations.

### **Related Works**

#### Top Management Support

Top management is critical factor for a successful ERP Post implementation. Also it requires to have huge resources to handle the complex situations arise from the ERP implementation. This needs the support and approvals of the top management. Also top management involvement is critical to handle the resistance from employees of the organization. It is best to start ERP implementation with the support of top management and this will definitely critical to a successful implementation (Leon, 2004).

#### Customization

Processes are different from factory to factory in Sri Lankan garment industry. Also factories are reluctant to change the existing processes for the best case practices. Therefore it required to have numerous customizations to support the garment manufacturing companies. The biggest mistake which organizations do is that customizing the software to suit the processes of the company (Millman, 2004). During an upgrade to a newer version of the ERP system automatically will not adjust to the new version of the ERP-system. Re-customization will be required in this case.

ERP system software is generally standardized system and many organizations would need to customize the ERP in order to support the business. This customization has to be carried out by external vendors or internally trained team. But over customization would make more complex and the business process would also have an impact. Customization will not give any cost benefit to the company as well. (Panorama, 2013).

#### Pre Implement- Success

Post Implementation success for an ERP for a given organization cannot be considered in a vacuum. Extensive understanding and thorough planning in the pre-implementation stage is a critical success factor in the post implementation stage. Pre Implementation activities such as project decisions, initial change management, business process mapping, and selection of the product are some of the main pre implementation considerations. Furthermore mentioned that “The post implementation experience relates directly, correlates directly to the pre-implementation experience” (Sullivan, 2009).

#### Operations and Maintenance

Successfully implemented ERP system would not automatically produce results; constant monitoring and management is essential for that. To gain maximum benefits in the Post Implementation stage, organizations should have continuous improvement, continuous learning and upgrades in their maintenance phase (Leon, 2004).

#### Change Management

Many companies struggle throughout the implementation stage because of underestimating the complexity and the lack of experience involved with change process (Hawking et al, 2004). There are problems faced by the organizations in the application of change management and the implementation of ERP. There are many employees and managers who are reluctant to change their organizational structure as required by ERP. They aren't disagreeing with the ERP but according to them nothing exists there for change management. However, employees who preferred tested traditional ways of management usually not willing to accept the ERP formulation and thus can show fearfulness towards it (Kurupparachchi et al., 2002).

## Methodology

### Population

Population will consists of total number of employees using ERP system at the selected garment manufacturing organizations and external consultants for this research which was around 350.

### Sample Size

Sample was selected using non probability sampling technique called the convenience sampling. This was done because of the convenient accessibility and proximity to the researcher. (n = 100)

Data collection methods and techniques used for research analysis are interview questionnaires.

Concept	Variable	Indicator	Measurement
Independent Variable	Top management Support	Project support Clearly defined business goals Benefits to strategic business units Appointment of steering committee User support	5 questions based on 1-5 Likert Scale (Q1-Q5)
	Change Management	Change Agents User Trainings User support	5 questions based on 1-5 Likert Scale (Q6-Q10)
	Operations and Maintenance	User trainings for new users and refresher trainings System reviews Help desk	5 questions based on 1-5 Likert Scale (Q11-Q15)
Independent Variable	Pre Implementation Success	Information gathering ERP Product selection Planning Standardising business process	4 questions based on 1-5 Likert Scale (Q16-Q19)
	Pre Implementation Success	Information gathering ERP Product selection Planning Standardising business process	4 questions based on 1-5 Likert Scale (Q16-Q19)
Independent Variable	Customization	Complex and bugs Suits Upgrade to the next version	4 questions based on 1-5 Likert Scale (Q20-Q23)
	Post Implementation Audit & Reviews	System audits carried out Audit and review in months Suggestions implemented	3 questions based on 1-5 Likert Scale (Q24-Q26)
Independent Variable	Business Process Reengineering	Quality, customer service and employee satisfaction Performance, profits, business practices, productivity and cost reductions Preparation and planning	5 questions based on 1-5 Likert Scale (Q27-Q31)
	Post Implementation Success	Benefits to the organization Company effort	3 questions based on 1-5 Likert Scale (Q32-Q34)

The above operationalization table determines the areas such as concept, variables, measurements and indicators which has been used in carrying out the research and specifically preparing the questionnaire.

## Detail Approach

### Descriptive Statistics

Total ERP Satisfaction level by user opinion and the correlations between the variables are obtained using descriptive statistics.

### Statistical Approach

#### Stepwise Regression Analysis

Stepwise regression approach is used to deal with the multicollinearity effect when performing a regression analysis. It is a method of regressing multiple variables while simultaneously removing those that aren't important each time removing the weakest correlated variable.

#### Principal Component Analysis

It is the more commonly used technique and more accurate than stepwise regression to deal with the effect of multicollinearity. The objective of principal components analysis is to explain the maximum amount of variation with the fewest number of principal components avoiding the multicollinearity.

Correlations					
		Operation & Maintenance	Pre Implementation	Customization	Business Process Reengineering
ERP Success	Pearson Correlation	.648**	.722**	.476*	.826**
	Sig. (2-tailed)	.000	.000	.000	.000
	N	100	100	100	100
Audit Review	Pearson Correlation	.170	-.203	-.255	.021
	Sig. (2-tailed)	.091	.043	.010	.839
	N	100	100	100	100
Top Management	Pearson Correlation	.635**	.766**	.472*	.796**
	Sig. (2-tailed)	.000	.000	.000	.000
	N	100	100	100	100
Change Management	Pearson Correlation	.754**	.826**	.580**	.747**
	Sig. (2-tailed)	.000	.000	.000	.000
	N	100	100	100	100
Operation & Maintenance	Pearson Correlation	1	.713**	.617**	.765**
	Sig. (2-tailed)		.000	.000	.000
	N	100	100	100	100
Pre Implementation	Pearson Correlation	.713**	1	.638**	.745**
	Sig. (2-tailed)	.000		.000	.000
	N	100	100	100	100
Customization	Pearson Correlation	.617**	.638**	1	.563**
	Sig. (2-tailed)	.000	.000		.000
	N	100	100	100	100
Business Process Reengineering	Pearson Correlation	.765**	.745**	.563**	1
	Sig. (2-tailed)	.000	.000	.000	
	N	100	100	100	100

\*\* . Correlation is significant at the 0.01 level (2-tailed).

\* . Correlation is significant at the 0.05 level (2-tailed).



		Correlations		
		ERP Success	Audit Review	Top Management
ERP Success	Pearson Correlation	1	-.167	.854
	Sig. (2-tailed)		.097	.000
	N	100	100	100
Audit Review	Pearson Correlation	-.167	1	-.085
	Sig. (2-tailed)	.097		.402
	N	100	100	100
Top Management	Pearson Correlation	.854**	-.085	1
	Sig. (2-tailed)	.000	.402	
	N	100	100	100
Change Management	Pearson Correlation	.725**	-.100	.831**
	Sig. (2-tailed)	.000	.324	.000
	N	100	100	100
Operation & Maintenance	Pearson Correlation	.648**	-.170	.635**
	Sig. (2-tailed)	.000	.091	.000
	N	100	100	100
Pre Implementation	Pearson Correlation	.722**	-.203	.766**
	Sig. (2-tailed)	.000	.043	.000
	N	100	100	100
Customization	Pearson Correlation	.476**	-.255*	.472**
	Sig. (2-tailed)	.000	.010	.000
	N	100	100	100
Business Process Reengineering	Pearson Correlation	.826**	.021	.796**
	Sig. (2-tailed)	.000	.839	.000
	N	100	100	100

\*\* . Correlation is significant at the 0.01 level (2-tailed).  
\* . Correlation is significant at the 0.05 level (2-tailed).

Below results are obtained from the stepwise regression analysis.

Table 04: Variables Entered/Removed

Model	Variables Entered	Variables Removed	Method
1	Top Management		Stepwise (Criteria: Probability-of-F-to-enter <= .050, Probability-of-F-to-remove >= .100).
2	Business Process Reengineering		Stepwise (Criteria: Probability-of-F-to-enter <= .050, Probability-of-F-to-remove >= .100).
3	Audit Review		Stepwise (Criteria: Probability-of-F-to-enter <= .050, Probability-of-F-to-remove >= .100).

Table 04 illustrates the variables used to build the model. It starts with zero predictors and then adds the strongest predictor, top management, to the model if its b-coefficient is statistically significant ( $p < 0.05$ , see last column). Table illustrates the variables used to build the model. It starts with zero predictors and then adds the strongest predictor, top management, to the model if its b-coefficient is statistically significant ( $p < 0.05$ , see last column).

And like wise include the next strongest predictor such a way that there is no significance auto correlations among the independent variables selected.

Table 05: Model Summary

Model Summary <sup>a</sup>										
Model	R	R Square	Adjusted R Square	Std. Error of the Estimate	Change Statistics					Durbin-Watson
					R Square Change	F Change	df1	df2	Sig. F Change	
1	.854 <sup>a</sup>	.730	.727	42019	.730	264.890	1	98	.000	
2	.888 <sup>b</sup>	.788	.784	37410	.058	28.639	1	97	.000	
3	.897 <sup>c</sup>	.805	.799	36031	.017	8.567	1	96	.004	1.728

a. Predictors: (Constant), Top Management  
b. Predictors: (Constant), Top Management, Business Process Reengineering  
c. Predictors: (Constant), Top Management, Business Process Reengineering, Audit Review  
d. Dependent Variable: ERP Success

Table 05 represent the best model as number 3 where it explains the 80% of the variation of the response variable by the model. Durbin Watson value around 2 depicts that there is no autocorrelation in the sample.

Table 06 : ANOVA Table

Model		Sum of Squares	df	Mean Square	F	Sig.
1	Regression	46.768	1	46.768	264.890	.000 <sup>a</sup>
	Residual	17.303	98	.177		
	Total	64.071	99			
2	Regression	50.496	2	25.248	180.409	.000 <sup>a</sup>
	Residual	13.575	97	.140		
	Total	64.071	99			
3	Regression	51.608	3	17.203	132.510	.000 <sup>a</sup>
	Residual	12.463	96	.130		
	Total	64.071	99			

a. Dependent Variable: ERP Success  
b. Predictors: (Constant), Top Management  
c. Predictors: (Constant), Top Management, Business Process Reengineering  
d. Predictors: (Constant), Top Management, Business Process Reengineering, Audit Review

The F-test is highly significant, ( $p\text{-val} < 0.05$ ) thus it proves that there is a linear relationship between the variables in the model 3.

Table 07: Table of Coefficients

Coefficients <sup>a</sup>															
Model		Unstandardized Coefficients		Standardized Coefficients	t	Sig.	95.0% Confidence Interval for B			Correlations			Collinearity Statistics		
		B	Std. Error				Lower Bound	Upper Bound	Zero-order	Partial	Part	Tolerance	VIF		
1	(Constant)	1.069	.176		6.069	.000	.719	1.419							
	Top Management	.787	.048	.854	16.275	.000	.691	.883	.854	.854	.854	1.000	1.000		
2	(Constant)	.250	.223		1.119	.266	-.193	.693							
	Top Management	.495	.071	.537	6.946	.000	.353	.636	.854	.576	.325	.366	2.734		
	Business Process Reengineering	.516	.100	.399	5.161	.000	.317	.714	.829	.484	.241	.366	2.734		
3	(Constant)	.604	.247		2.449	.016	.114	1.094							
	Top Management	.461	.070	.500	6.621	.000	.323	.599	.854	.500	.298	.356	2.812		
	Business Process Reengineering	.557	.087	.431	5.729	.000	.384	.750	.829	.505	.259	.359	2.763		
	Audit Review	-.138	.044	-.134	-2.927	.004	-.215	-.041	-.167	-.289	-.132	.872	1.029		

a. Dependent Variable: ERP Success

According to the table 07 all independent variable coefficients are statistically significantly different from zero in the model 3. Tolerance values greater than 0.2 and VIF value  $< 5$  indicates the nonexistence of the correlations between the independent variables in model 3.

According to the Table 08 top management and business process reengineering variables have a higher variance proportion in dimension 4 in model 3 indicating the existence of the collinearity among these two variables. At the same time Audit review has a significant variance proportions in two dimensions suggesting to carry out a further multicollinearity dimension redundancy analysis.

Below results are obtained from the Principal Component Analysis.

**Table 09 :KMO and Bartlett's Test**

Kaiser-Meyer-Olkin Measure of Sampling Adequacy.	.826
Approx. Chi-Square	551.732
Bartlett's Test of Sphericity	df
Sig.	.000

Kaiser-Meyer-Olkin (KMO) Measure (between 0-1) of Sampling Adequacy for the overall data set where the high value which is 0.826, is considered to be good. Bartlett's significance test verify the existence of the multicollinearity and the appropriateness the of applying the PCA analysis to the dataset. Sig < 0.5 indicate that the correlation matrix of the independent variables are not an identity matrix.

**Table 10: Communalities**

	Initial	Extraction
Top Management	1.000	.764
Change Management	1.000	.843
Operation & Maintenance	1.000	.823
Pre Implementation	1.000	.843
Customization	1.000	.617
Audit Review	1.000	.957
Business Process	1.000	.817
Reengineering	1.000	.817

Extraction Method: Principal Component Analysis.

Values in this extraction column indicate the proportion of each variable's variance that can be explained by the principal components where variables with high values are considered to be well represented variables.

**Table 11: Total Variance Explained**

Component #	Initial Eigenvalues			Extraction Sums of Squared Loadings			Rotation Sums of Squared Loadings		
	Total	% of Variance	Cumulative %	Total	% of Variance	Cumulative %	Total	% of Variance	Cumulative %
1	4.512	64.464	64.464	4.512	64.464	64.464	4.482	64.028	64.028
2	1.151	16.446	80.910	1.151	16.446	80.910	1.182	16.882	80.910
3	.576	8.226	89.136						
4	.262	3.743	92.879						
5	.216	3.092	95.971						
6	.176	2.521	98.492						
7	.106	1.508	100.000						

Extraction Method: Principal Component Analysis.

Eigenvalues are the variances of the principal components. All the variables are standardized, which means that the each variable has a variance of 1, and the total variance is equal to the number of variables used in the analysis, in this case, 7. The first component will always account for the most variance and the next component will account for as much of the left over variance as it can, and so on. Hence, each successive component will account for less and less variance. The first principal component explains about 64% of the variation while the first three principal components explain 89% of the variation.

According to the table only 2 components have been extracted by the PCA analysis.

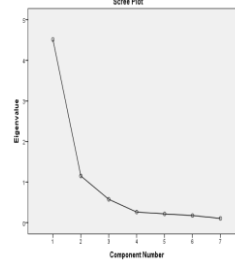

Figure 03 : Scree Plot

Values in the first two columns of the figure 03 have a narrow slope. From the third component on, the line is almost flat, meaning the each successive component is accounting for smaller and smaller amounts of the total variance. In general, it extracts only those principal components whose eigenvalues are greater than 1.

**Table 12: Component Matrix**

	Component	
	1	2
Top Management	.874	.031
Change Management	.918	.008
Operation & Maintenance	.858	.298
Pre Implementation	.909	-.128
Customization	.735	-.278
Audit Review	-.108	.972
Business Process	.890	.155
Reengineering		

Extraction Method: Principal Component Analysis.

a. 2 components extracted.

The first principal component is strongly correlated with six of the original variables. The first principal component increases with increasing Top Management, Change management, Operations & aintenance, Pre Implementation, Customization and BPR. The second principal component increases with the increment of Audit Review.

Below results are obtained from the Correlation Analysis with the standardized ERP Success values and the extracted principal components.

**Table 14: Correlations**

		Zscore: ERP Success	PCA1	PCA2
Zscore: ERP Success	Pearson Correlation	1	.824 <sup>**</sup>	-.167
	Sig. (2-tailed)		.000	.097
	N		100	100
PCA1	Pearson Correlation	.824 <sup>**</sup>	1	-.083
	Sig. (2-tailed)	.000		.412
	N		100	100
PCA2	Pearson Correlation	-.167	-.083	1
	Sig. (2-tailed)	.097	.412	
	N		100	100

\*\* . Correlation is significant at the 0.01 level (2-tailed).

According to the Table 14, the linear relationship between response variable and PCA 1 is significance.

### Discussion

There are very limited number of researches carried out about post implementation

effects in garment manufacturing organizations in the world.

This is an attempt to provide comprehensive knowledge to the newcomers who are entering to the Garment Industry and for the users who are currently engaged in the Post – ERP Implementation Stage and also apart from that to check whether, to what extent the issues face and the factors effect to Post ERP Implement in Global Industry can be relevant to the Sri Lankan Industry.

Furthermore as there are some significant differences in some factors such as technology complexity, technology performances and ease of business logic Modifications by the ERP software system wise, this research will be very much accurate, useful and add a great value to the users who are working with Microsoft ERP vendors and for the users who are hoping to Implement their industry with Microsoft Dynamics AX.

The key factors with effects to the post ERP implementation were found out at the initial descriptive analysis, but the existence of the multicollinearity lead the analysis for the next level.

Below hypothesis were carried out to check the significance of the linear relationship between the independent variables and dependent variable.

#### Hypothesis 1

H<sub>10</sub>: ‘Top Management support’ in an ERP project does not influence ERP Post-Implementation success.

H<sub>1a</sub>: ‘Top Management support’ in an ERP project positively influence ERP Post-Implementation success.

#### Hypothesis 2

H<sub>20</sub>: ‘Change Management’ in an ERP project does not influence ERP Post-Implementation success.

H<sub>2a</sub>: ‘Change Management’ in an ERP project positively influence ERP Post-Implementation success.

#### Hypothesis 3

H<sub>30</sub>: ‘Operations and Maintenance’ in an ERP project does not influence ERP Post-Implementation success.

H<sub>3a</sub>: ‘Operations and Maintenance’ in an ERP project positively influence ERP Post-Implementation success.

#### Hypothesis 4

H<sub>40</sub>: ‘Pre-Implementation Success’ in an ERP project does not influence ERP Post-Implementation success.

H<sub>4a</sub>: ‘Pre-Implementation Success’ in an ERP project positively influence ERP Post-Implementation success.

#### Hypothesis 5

H<sub>50</sub>: ‘Customization’ in an ERP project does not influence ERP Post-Implementation success.

H<sub>5a</sub>: ‘Customization’ in an ERP project positively influence ERP Post-Implementation success.

H<sub>60</sub>: ‘Post-Implementation Audit’ in an ERP project does not influence ERP Post-Implementation success.

H<sub>6a</sub>: ‘Post-Implementation Audit’ in an ERP project positively influence ERP Post-Implementation success.

#### Hypothesis 7

H<sub>70</sub>: ‘Business Process Reengineering’ in an ERP project does not influence ERP Post-Implementation success.

H<sub>7a</sub>: ‘Business Process Reengineering’ in an ERP project positively influence ERP Post-Implementation success.

Rejection Criteria: Reject null hypothesis if  $p\text{-val} < 0.05$

Stepwise Regression Analysis and the Principal Component Analysis were carried out respectively in order to deal with the high multicollinearity.

#### Stepwise Regression

Only three of the variables were extracted by the stepwise regression analysis and model 3 was used in the entire stepwise process (Table 05)

The *F*-ratio in the ANOVA table (Table 06) tests whether the overall regression model is a good fit for the data

#### Hypothesis 8

H<sub>80</sub>: There is no linear relationship between the response variable and the independent variables (in model 3).

H<sub>8a</sub>: There is a linear relationship between the response variable and the independent variables (in model 3).

Rejection Criteria : Reject null hypothesis if  $p\text{-val} < 0.05$

The Durbin Watson statistic is a number that tests for autocorrelation in the residuals from a statistical regression analysis. The Durbin-Watson statistic is always between 0 and 4. A value of 2 means that there is no autocorrelation in the sample. Values approaching 0 indicate positive autocorrelation and values toward 4 indicate negative autocorrelation.

#### Table 07

#### Hypothesis 9

H<sub>90</sub>: All the coefficients of the independent variables are zero (in model 3).

H<sub>9a</sub>: Not at least one independent variable is equals to zero (in model 3).

Tolerance and the VIF values under the collinearity statistics indicate the existence of the multicollinearity effects

Values  $< 0.2$  for tolerance and values  $> 5$  indicates high multicollinearity.

(VIF = 1/Tolerance)

#### Principal Component Analysis

Kaiser-Meyer-Olkin (KMO) Test is a measure of how suited the data is for Factor Analysis. The test measures sampling adequacy for each variable in the model and for the complete model. The statistic is a measure of the proportion of variance among variables that might be common variance.

KMO returns values between 0 and 1. A rule of thumb for interpreting the statistic:

KMO values between 0.8 and 1 indicate the sampling is adequate.

KMO values less than 0.6 indicate the sampling is not adequate and that remedial action should be taken. Some authors put this value at 0.5, so use your own judgment for values between 0.5 and 0.6.

KMO Values close to zero means that there are large partial correlations compared to the sum of correlations. In other words, there are widespread correlations which are a large problem for factor analysis.

All the variables are standardized before applying to the Analysis. Two principal components were extracted by the Principal Component Analysis and it was checked for the linear relationship with the response variable.

#### **Conclusion**

Users don't have a proper idea about the benefits of an ERP system affects to the organization. Even though the majority of the respondents satisfied with the ERP, there are considerable portion of the respondents who doesn't have any idea about how the ERP systems benefited the company (Figure 02)

All the factors except Audit Review are distributed around the mean 3.5 indicating that for each of these factors are considered as in the level of "Agreed". (Table 02)

The research highlights the critical factors to be looked at ERP post implementation phase to achieve the maximum benefits. Sri Lankan garment manufacturing organizations are not reaping the best out of ERP implementations due to placing less effort on ERP post implementation phase.

Researcher identified that post implementation audit and review is not having significant relationship with the ERP post implementation success factor. All the other factors are having strong to moderate relationships. But the existence of the correlations among the independent variables avoid the researcher to get into the conclusion with the factors which only linearly relate well with ERP success factor themselves, while leading to the existence of the multicollinearity when fitting a regression model. (Table 03)

And to deal with multicollinearity the stepwise regression analysis and the principal component analysis were carried out.

Only 3 independent variables are considered to be the appropriate factors with non-auto correlations, in the stepwise regression analysis. (Table 04)

The regression model derived by the stepwise analysis is,

$$\text{Post ERP Success} = 0.604 + 0.461 * \text{Top Management} + 0.557 * \text{Business Process reengineering} - 0.128 * \text{Audit Review}.$$

But the output from the collinearity diagnostics lead to perform a dimension redundancy test which is very commonly use the Principal Component Analysis.

Only two components were extracted by the PCA analysis which had an eigenvalue greater than 1. (Table 11/ Figure 03)

The first principal component is strongly correlated with six of the original variables. The first principal component increases with top management, change management,

operation & maintenance, pre implementation, customization and BPR. This suggests that these six criteria vary together. If one increases, then the remaining ones tend to as well. Audit review can be excluded as it weekly correlates to the first principal component.

$$\text{PCA 1} = 0.874 * \text{Top Management} + 0.918 * \text{Change Management} + 0.858 * \text{Operations \& Maintenance} + 0.909 * \text{Pre Implementation} + 0.735 * \text{Customization} + 0.89 * \text{Business Process reengineering}$$

The second principal component increases with only one of the values, increasing audit review. This component can be viewed as a measure of how audit review performs in terms of having proper review plans in every 6 months, suggestions of review include into ERP systems, etc.

$$\text{PCA 2} = 0.972 * \text{Audit Review}$$

Final Regressions analysis were carried out taking dependent variable as the success factor and independent variables as PCA1 and PCA2 where the 2 components are uncorrelated.

Coefficient for PCA2 is not significance, hence conclude that only PCA1 component has a significant linear relationship to the dependent variable. In another words the initial variables, Top Management, Change Management, Customization, Pre implementation, Operations and Maintenance and BPR only have a linear relationship with the response variable. (Table 14)

## References

Chang, H et al., 2011, 2013 "ERP Post - Implementation Learning, ERP Usage and Individual Performance Impact."

Panarama Consulting Solutions , 2013 "A Panorama Consulting Solutions Research Report",2013 ERP Report.

J.Jayasinghe , 2004 "Framework for Post Evaluation of Implementation of ES Systems,"

M.S. thesis, Dept. Computer Science. Eng., Moratuwa Univ., Moratuwa, Sri Lanka, 2004.

Leon, Alexis, 2008. ERP DEMYSTIFIED .2nd .New Delhi :Tata McGraw Hill.p3-345.

Linda s. Sullivan, 2013, 2009. "Post-implementation success factors for enterprise resource planning (erp) student administration systems in higher education institution".

Millman, Gregory J. 2004 "What Did you Get From ERP, and What Can You Get? Fei Financial Executives International".

Kuruppuarachchi, P., Mandal, P., Smith, R., 2002. "IT project implementation strategies for effective changes", A critical review. Logistics Information Management (2), 126-137.

T.S. Madurapperuma, Y.K.D. Galkotuwa, G.L.C.A. Gunawardana, R.A.D.K.M. Ramanayaka, D.R.H. Walpola and S. Thelijjagoda, 2009 "ERP Deployment in Manufacturing Industry in Sri Lankan Context", Department of Business and Information Management, Sri Lanka Institute of Information Technology, Malabe.

Shiromi Arunathilaka, 2004 "E-Transformation Strategy for the Sri Lankan Garment Industry", Western Sydney University, Sydney, New South Wales, Australia.

## Acknowledgement

I thank all the garment factories which helped me a lot and also users for the help given in the survey and the interviews which was helped me immensely to complete the dissertation. Specially I would like to express my sincere gratitude to Mr. S.L.A. Munasinghe, Consultant data analytics of Altria Consulting for the continuous support of my study and related research.

## Author Biographies



Balage HD Perera received the BSc (Special) Degree in Mathematics from University of Ruhuna, Sri Lanka. Later she assumed the duties as a temporary demonstrator at the University of Ruhuna, Sri Lanka. She is following an MSc in Financial Mathematics from University of Moratuwa, Sri Lanka. She currently serves as a Lecturer (Prob) attached to the department of Computational Mathematics at General Sir John Kotelawala Defence University, Sri Lanka.

## Clustering Crimes Related Twitter Posts using WordNet and Agglomerative Algorithm

S.P.C.W Sandagiri, B.T.G.S Kumara, K. Banujan

*Department of Computing and; Information Systems, Sabaragamuwa University of Sri Lanka, Belihuloya, Sri Lanka*

bhakhuha@appsc.sab.ac.lk

**Abstract:** Crime is a major problem faced today by society. Crimes have affected the quality of life and economic growth badly. We can identify the crime patterns and predict the crimes by detecting and analyzing the historical data. We can use social media like twitter to detect crimes related activities. Because Twitter users sometimes convey messages related to his or her surrounding environment via twitter. In this paper, we proposed a machine learning approach to cluster the crime-related twitter post based on the crime category. The empirical study of our prototyping system has proved the effectiveness of our proposed clustering approach.

**Keywords:** Clustering, WordNet, Agglomerative algorithm, SVM

### Introduction

A crime is a criminal act and can be enforced by a state or other body. Police collect criminality data from the field based on an individual or group's records. The police will determine the crimes which have occurred from the data. Police may not have evidence of violence from other groups (Gemasih et al., 2019). Research of crime has been a vital tool to help law enforcement officers protect people. Crime levels have risen significantly as a result of an increasingly growing population and effective research has been a time-consuming endeavor (Hissah and Al-Dossari, 2018).

We are now at a point where many human needs and requests can be found in online resources (Yang et al., 2011). In addition to the increasing market, there are also many officials, military, medical and private knowledge available online (Hernández et al., 2016). The proliferation of online infrastructure has also improved the way users connect on-line. Several web services allow users to communicate in real-time (Hernández et al., 2016).

Nowadays, with a rising number of Internet users, and the ease of connectivity provided by the proliferation of mobile data technologies, the amount of knowledge related crimes to be accessed and analyzed is growing correspondingly. Much of this material remains unstructured in the context of "free text." This phenomenon has resulted in a growing interest in the production of unstructured data processing approaches (Hissah and Al-Dossari, 2018). The material in social media provides rich qualitative knowledge about the everyday lives of its users, based on textual details shared. Each textual post is compiled on the service providers platform (Chen et al., 2015).

There are currently many social media sites, such as Facebook, Twitter, and Snapchat. Twitter, which is one of the most common social networking sites for casual chats, sharing photos and ideas and transferring information and news via text, limited to 280 characters, called "tweets" (Hissah and Al-Dossari, 2018). Social networking sites can uncover useful information as a systematic

analysis of their unstructured data is implemented (Chen et al., 2015).

Text mining is an important method and can help to address this issue by efficiently classifying crimes. The program introduced for identifying and classifying crime related posts on Twitter (Hissah and Al-Dossari, 2018)

Throughout time, experiments have been undertaken to understand the nature of criminal behavior, classifying people by their racial or cultural context, or designing techniques of deterrence, detection, and 'effective' discipline. Governments around the world are investing huge amounts on crime prevention, law enforcement, and public intelligence. As a result, in recent years people have observed the growing number of CCTV cameras looking at the streets of all big cities, which is controversially detected and discussed. However, crime monitoring is now enabled by electronic networks and databases that include access to virtualized neighborhood observation and official records of crime (Bendler et al., 2014).

Although most experiments are restricted to particular places, forms of crime, neighborhoods, and consumers, or concentrate on unique incidents, we will generalize our suggested solution to any area. Hence, the primary aim of this work is to collect available, reliable information (tweets) to recognize the essence of crimes and to assist law enforcement with future crime reduction, thus adding to the welfare of mankind. As an initial step, we clustered the Crime Related Twitter Posts using WordNet and Agglomerative Algorithm.

The remainder of the paper is organized as follows. Section II describes the Literature Review. Section III explains the proposed approach while Section IV explains results and discussion. Finally, Section V concludes the paper with future directions.

## Literature Review

Analysis of crime was researched extensively and different theories and methods emerged (Wang et al., 2012, Eck et al., 2005, Gerber, 2014, Caplan and Kennedy, 2011, Wang and Brown, 2011). Cohen and Felson concentrated primarily on offenses requiring overt interaction with criminals and individuals who were targeted (e.g. physical assault). They called these offenses malicious abuses of direct contact (Cohen and Felson, 1979).

The details that Twitter users share in a tweet normally include something specific to themselves or their environment, like the incident of a crime (Gemasih et al., 2019). GPS-tagged Twitter data allow for potential crime prediction in major cities (Chen et al., 2015)

Wang et al. (2012)'s previous research concentrated solely on recent department tweets to establish the correlation between subjects used in tweets and different forms of criminal accidents (Wang et al., 2012). Gerber (2014) further developed the prediction model by subject modeling (Gerber, 2014). He combined incidents of historical crime with GPS-tagged Twitter data collected from all twitter users in the Chicago city area. Such simulations, however, mostly found subject modeling but did not extend Twitter data to sentiment analysis.

Gonzalez et al. (2008) measure the distribution of human spatial probability by measuring regularities in both the temporal and spatial dimensions. The authors focus on their analysis of spatial data obtained from cell phone usage, where each user's estimated location can be determined from the mobile phone towers their phone is registered at. Arase et al. (2010) rely on consumer trip data to include recommendations for travel routes based on trends collected. Similarly, Scellato et al. (2011) forecast device positions based on



trends discovered by measuring data from a non-linear time series. The authors test their approach on various data sources (e.g. GPS tracks, WiFi connection points) and can substantially increase prediction precision over Markov Spatio-temporal predictors. Cho et al. (2011) indicate that the patterns of human migration are strongly intermittent, but contribute in part to the studied individual's social network when it comes to long-term travel. Backstrom et al. (2010) go further and prove that a person's geospatial location can only be predicted by individual locations within the respective social network.

### Proposed Approach

Figure 1 shows the overall methodological framework used for the study. First, twitter posts are extracted using crime related keywords. Then, preprocessing techniques are applied to clean the data set. Next, twitter posts are transformed into vectors to generate the feature vectors in the data preparation step. Then, the Support Vector Machine (SVM) model is constructed to classify the data set. Next, calculate the similarity between twitter posts using WordNet. Finally, the agglomerative clustering algorithm is applied to classify the posts.

#### A. Data collection

Twitter posts are collected through the Search API (available at <http://twitter.com>) of Twitter. The search of the twitter posts must be based on a set of keywords that can be used to classify the crime situations. Then, twitter posts are labeled based on the contents used to create the training set. The collected data set consists of more than 100,000 twitter posts from 2020 January 01 to 2020 January 31.

#### B. Data Pre-processing

As a next step, pre-processing techniques should be applied to the extracted collection

of data. Since typos, unnecessary items such as URLs and stop words in the twitter post can be available. Data gathered from twitter are often extremely unstructured and noisy. Clean tweet data are produced by pre-processing techniques that will be used for the next process.

First, we deleted stop words like, is, which, the, have, etc. The words convey no positive or negative significance. So, without affecting the meaning of the message, we can easily remove the stop word. We deleted then URLs, hashtags, symbols, usernames, terms, quotes, etc. Next, combine words with tokenization techniques. Finally, we used a stemming algorithm to simplify the word to a stem that contains suffixes, prefixes, or word roots.

Some tweets may contain text that seems irrelevant to the process of an analysis of sentiments. Candidate markers such as URL's, responses to other users and frequently occurring stop words are considered noise (Choy, 2012). To remove such unwanted contents, a noise reduction method was used.

#### C. Data Preparation

After completing the pre-processing, twitter posts are transformed into vectors to generate the feature vectors. The vectors are used in the learning phase for machine learning algorithms. In this research, we used the term frequency-inverse document frequency (TF-IDF) values to create the vectors. TF-IDF value reflects the importance of a term in a document to the collection of documents as in the following equation (Equation 1).

$$tfidf_{x,p} = tf_{x,p} \log \log \left( \frac{n}{pn_x} \right) \quad (1)$$

Here,  $tfidf_x$  is the TF-IDF value for term  $x$  in post  $P$ .  $tf_{xp}$  is the term frequency of term  $x$  in post  $P$ .  $pn_x$  is the number of posts that contain term  $x$ . Parameter  $n$  is the total number of posts.

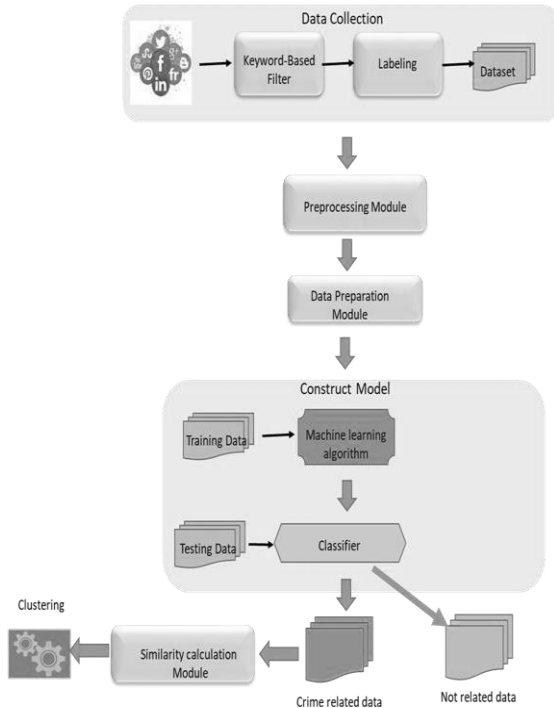

Figure 1: High-level architectural framework

#### D. Constructing the SVM model

We have used the SVM as the machine learning algorithm. The SVM is a state-of-the-art classification method that uses a learning algorithm based on structural risk minimization. The classifier can be used in many disciplines because of its high accuracy, ability to deal with high dimensions, and flexibility in modeling diverse sources of data. The output of SVM indicates the distance between testing data and the optimal hyperplane. We

prepared a training dataset  $D = [(x_1, y_1), (x_2, y_2), \dots, (x_n, y_n)]$ , where  $x_i$  is the feature vector and  $y_i$  is the expected class label for the  $i$ th instance. The SVM is then trained with the labeled feature vectors to categorize the crime-related data and non-related data.

#### E. Calculating semantic similarity between twitter posts

After identifying the crime-related post using SVM, we need to cluster the post based on the crime types. As the first step in this stage, the semantic similarity between posts is calculated. We used WordNet as the knowledge base to calculate the semantic similarity of the posts.

WordNet is a lexical database of semantic relationships in more than 200 languages between words. WordNet connects words into semantic relationships that include synonyms, hyponyms, and meronyms. The synonyms are organized into synsets with descriptions of brief meanings and use.

WordNet resembles a thesaurus superficially, in that it brings together words based on their meanings. There are some major differences, however. Firstly, WordNet not only interlinks word forms - strings of letters - but unique words meaning. As a consequence, terms contained in the network close to each other are disambiguated semantically. Second, WordNet marks the semantic associations between words, while the groupings of terms in a thesaurus follow no other clear pattern than similarity.

Here to calculate the semantic similarity using WordNet, we applied an edge-count-based approach. First, the similarity between individual term pairs are calculated as follows (Equation 2);

$$Semantic_{(T_{ai}, T_{bj})} = WN\_Sim(T_{ai}, T_{bj}) \quad (2)$$

Here,  $T_{ai}$  is the  $i$ th term of post  $a$ , and  $T_{bi}$  is the  $j$ th term of post  $b$ .

Then, the final similarity value between post  $a$  and  $b$  are obtained using the following equation (Equation 3).

$$Sim(a, b) = \sum_{p=1}^l \sum_{q=1}^m \frac{max\_sim(x_p, y_q)}{(l+m)} \quad (3)$$

Where  $x_p$  and  $y_q$  denote the individual terms, with  $l$  and  $m$  being the number of individual terms in twitter posts  $a$  and  $b$ , respectively.

## F. Clustering crimes related posts.

We used an agglomerative clustering algorithm (Algorithm 1) as the clustering algorithm. This bottom-up hierarchical clustering method starts by assigning each twitter post to its cluster (see Line 1 in Algorithm 1). It then starts merging the most similar clusters, based on proximity of the clusters at each iteration, until the stopping criterion is met (e.g., number of clusters) (see Lines 4–10 in Algorithm 1).

Table 1: Algorithm 1 Clustering Algorithm.

<b>Algorithm 1</b> Clustering	
Algorithm. <b>Input</b> S: Array of similarity values	
<b>Input</b> n: Number of required clusters	
<b>Output</b> C: clusters	
1:	Let each twitter posts be a cluster;
2:	ComputeProximityMatrix(S);
3:	k=NoOfPosts;
4:	<b>while</b> k !=n <b>do</b>
5:	Merge two closest clusters;
6:	k=getNoOfCurrentClusters();
7:	Calculate the center value of all posts in all clusters.
8:	Select post with the highest value of each cluster as cluster centers;
9:	UpdateProximityMatrix();
10:	<b>end while</b>

## Results and Discussion

The experiments were conducted on a computer running

Microsoft Windows 10, with an Intel Core i5-3770, 2.70 GHz CPU and 6 GB RAM. Python was used for SVM implementation. Java was used as the programming language in implementing the similarity calculation module and the agglomerative clustering algorithm. Crimerelated tweets were collected from Twitter API.

### A. Cluster Evaluation

We used precision, recall, and F-measure by using Equation 4, Equation 5, and Equation 6 respectively to measure the performance of our approach. Precision is the fraction of a cluster that comprises twitter posts of a

Table 2 Performance measures of clusters

specified class. A recall is the fraction of a cluster that comprises all posts of a specified class. We implemented a clustering approach using cosine similarities for comparison. Table 2 shows the experiment results.

$$\text{Precision} = \frac{TP}{TP+FP} \quad (4)$$

$$\text{Recall} = \frac{TP}{TP+FN} \quad (5)$$

$$f_1 = 2 \cdot \frac{\text{Precision} \cdot \text{Recall}}{\text{Precision} + \text{Recall}} \quad (6)$$

According to the experimental results (Table 2), for all other clusters, the WordNet-based approach obtained higher values for all the evaluation criteria. For example, the WordNet-based approach improved the precision value for the “Drugs Violations” cluster by 15.2%. Further, the WordNet-based approach improved the recall value for the “Assault” cluster by 16.0%.

### B. Sample clustering results

Table 3 shows the sample outputs of each cluster.

## Conclusion and Future Works

In this paper, we proposed an approach to cluster the crimelated posts from twitter. Here, first, we used the WordNet-based method to calculate the semantic similarity between twitter posts. Then, we applied the agglomerative clustering algorithm to cluster the posts based on calculated similarity values. The empirical study of our prototyping system has proved the effectiveness of our approach. It obtained 87.7% and 87.4 average precision and recall values respectively.

In future work, we planned to implement the crime prediction approach using SVM and deep neural network approach. Further, we planned to validate the tweets using news posts.

Cluster	WordNet-based Approach			Cosine similarity-based approach		
	Precision %	Recall %	F-Measure %	Precision %	Recall %	F-Measure%
Assault	86.9	86.0	86.4	70.0	75.3	72.6
Burglary	85.0	91.0	87.9	80.0	83.3	78.7
Drugs Violations	93.2	82.0	87.2	78.0	60.2	68.0
Homicide	83.8	93.0	88.2	81.0	74.3	77.5
Sex Offences	89.5	85.0	87.2	73.0	77.7	75.3

Table 3: Sample output

Cluster	Sample twitter posts
Assault	<ul style="list-style-type: none"> <li>📄 Police: Gun fires a shot after 6-year-old brings a gun to school in Wilcox County; parents arrested. ,</li> <li>📄 26 year old Gaza fisherman moderately injured by gunfire after Egyptian boats opened fire on fishermen at sea ,</li> <li>📄 A high ranking source at APD just told me, The 27-year-old man in custody for the Violent knife attack at Freebirds in South Austin Friday morning is a homeless/transient with a violent criminal history. @fox7austin ,</li> </ul>
Burglary	<ul style="list-style-type: none"> <li>📄 A foreign national was arrested, after being found in possession of a Toyota Corolla which was hijacked in Randburg. The driver reported the hijacking after he was taken hostage during the event.,</li> <li>📄 The New York police department arrested two teenage boys and charged them with gang assault and murder of 60-year-old Juan Fresnada that occurred during a \$1 robbery on Christmas Eve.,</li> <li>📄 The truck used in the robbery was stolen from Greenville, South Carolina, where three of the four occupants were from.,</li> </ul>
Drugs Violations	<ul style="list-style-type: none"> <li>📄 State Police Arrest Man for DWI and Seize \$315 Worth of Drugs During Traffic Stop The #NJSP have arrested Carl Welch, 39, of Kenvil, N.J. and Michael Zelaya, 30, of Dover, N.J. and seized \$315 worth of heroin and Xanax pills during a traffic stop,</li> <li>📄 An Oklahoma City man was sentenced last month to 30 years in prison for drug and firearm possession connected to drug trafficking,</li> <li>📄 Holyoke man arrested after police raid 2 homes, confiscate 2,500 bags of heroin , 1 lb. marijuana, gun.,</li> </ul>
Homicide	<ul style="list-style-type: none"> <li>📄 A Dubuque man has been arrested in Minnesota on a vehicular homicide charge related to a fatal motorcycle crash in August. ,</li> <li>📄 Henrico police have made an arrest into Thursday nights homicide . Deion L. Smallwood, 23, of Richmond was arrested and charged with murder.</li> </ul>
Sex Offences	<ul style="list-style-type: none"> <li>📄 A 55-year-old Sahuarita man was arrested on suspicion of sexual abuse Tuesday.,</li> <li>📄 Man sentenced to six years for north Edinburgh sex offences ,</li> <li>📄 CHILLING: Three people have been arrested in a child abuse investigation after Alabama authorities say children were locked in cages ,</li> </ul>

## References

- ARASE, Y., XIE, X., HARA, T. & NISHIO, S. Mining people's trips from large scale geo-tagged photos. Proceedings of the 18th ACM international conference on Multimedia, 2010. 133-142.
- BACKSTROM, L., SUN, E. & MARLOW, C. Find me if you can: improving geographical prediction with social and spatial proximity. Proceedings of the 19th international conference on World wide web, 2010. 61-70.
- BENDLER, J., RATKU, A. & NEUMANN, D. 2014. Crime mapping through geo-spatial social media activity.

CAPLAN, J. M. & KENNEDY, L. W. 2011. Risk terrain modeling compendium. *Rutgers Center on Public Security, Newark.*

CHEN, X., CHO, Y. & JANG, S. Y. Crime prediction using twitter sentiment and weather. 2015 Systems and Information Engineering Design Symposium, 2015. IEEE, 63-68.

CHO, E., MYERS, S. A. & LESKOVEC, J. Friendship and mobility: user movement in location-based social networks. Proceedings of the 17th ACM SIGKDD international conference on Knowledge discovery and data mining, 2011. 1082-1090.

CHOY, M. 2012. Effective listings of function stop words for twitter. *arXiv preprint arXiv:1205.6396.*

COHEN, L. E. & FELSON, M. 1979. Social change and crime rate trends: A routine activity approach. *American sociological review*, 588-608.

ECK, J., CHAINEY, S., CAMERON, J. & WILSON, R. 2005. Mapping crime: Understanding hotspots.

GEMASIH, H., RAYUWATI, R., SN, A. & MURSALIN, M. 2019. *Classification of Criminal Crimes From Data Twitter Using Class Association Rules Mining.*

GERBER, M. S. 2014. Predicting crime using Twitter and kernel density estimation. *Decision Support Systems*, 61, 115-125.

GONZALEZ, M. C., HIDALGO, C. A. & BARABASI, A.L. 2008. Understanding individual human mobility patterns. *nature*, 453, 779-782.

HERNÁNDEZ, A., SANCHEZ, V., SÁNCHEZ, G., PÉREZ, H., OLIVARES, J., TOSCANO, K., NAKANO, M. & MARTINEZ, V. Security attack prediction based on user sentiment analysis of Twitter data. 2016 IEEE international conference on industrial technology (ICIT), 2016. IEEE, 610617.

HISSAH, A.-S. & AL-DOSSARI, H. 2018. Detecting and Classifying Crimes from Arabic Twitter Posts using Text Mining Techniques. *International Journal of Advanced Computer Science and Applications (IJACSA)*, 9.

SCELLATO, S., MUSOLESI, M., MASCOLO, C., LATORA, V. & CAMPBELL, A. T. Nextplace: a spatio-temporal prediction framework for pervasive systems. International Conference on Pervasive Computing, 2011. Springer, 152-169.

WANG, X. & BROWN, D. E. The spatio-temporal generalized additive model for criminal incidents.

Proceedings of 2011 IEEE International Conference on Intelligence and Security Informatics, 2011. IEEE, 42-47.

WANG, X., GERBER, M. S. & BROWN, D. E. Automatic crime prediction using events extracted from twitter posts. International conference on social computing, behavioral-cultural modeling, and prediction, 2012. Springer, 231-238.

YANG, Y., LI, H. & DENG, G. A case study: behavior study of chinese users on the internet and mobile internet. International Conference on Internationalization, Design and Global Development, 2011. Springer, 585-593.

### Author Biographies



S. P. C. W Sandagiri an undergraduate student in the Sabaragamuwa University of Sri Lanka and will be graduating in 2020 with a BSc Special in Information Systems.



Banage T. G. S. Kumara received the Bachelor's degree in 2006 from Sabaragamuwa University of Sri Lanka. He received the master's degree in 2010 from the University of Peradeniya and the Ph.D. degree in 2015 from the University of Aizu, Japan. His research interests include semantic web, web data mining, web service discovery, and composition.



Kuhaneswaran Banujan received his Bachelor of Science degree in 2019 with the Second Class Upper Division from Sabaragamuwa University of Sri Lanka. He is currently attached to the Department of Computing and Information Systems as a Lecturer in Computer Science. His research interests include Data Mining, Knowledge Management, Ontology Modeling, Business Process Simulation

## SherLock: A CNN, RNN-LSTM Based Mobile Platform for Fact-Checking on Social Media

MDPP Goonathilake#, PPNV Kumara

*Department of Computer Science, General Sir John Kotelawala Defence University, Ratmalana, Sri Lanka*

#pathumveyron24@gmail.com

**Abstract:** Today, false news is easily created and distributed across many social media platforms. Due to that, people find it difficult to choose between right and wrong information on those platforms. Therefore, a strong need emerges to develop a fact-checking platform to overcome this problem. Fact-checking means the process of verifying information. A CNN, RNN-LSTM based mobile solution has proposed from this study to verify information on social media including many features. CNN, RNN-LSTM based hybrid model ables to capture the high-level features and long-term dependencies from the input text. Some of the features of the mobile application includes fact-checking, daily news updates, news reporting and social media trends etc. The mobile solution is developed using Flutter as the front-end framework and Firebase as the back-end framework including REST APIs to gather daily news articles. The hybrid model achieved a 92% accuracy when checking the information circulating on social media.

**Keywords** Fake News Detection, Fact-Checking, Deep Learning, Natural Language Processing, Hybrid Approach

### Introduction

Today out of 8 billion people worldwide 3.8 billion people are social media users. With the development of new social media platforms, people are moving from traditional news media to those social media platforms. Because they can easily get to know about the things which are happening around the world just surfing through social

media news feeds. As a consequence of the freedom and simplicity gives from those social media platforms anyone can express anything at any time and this leads to create and distribute false information comfortably through those platforms. Due to that, people find it difficult to choose between right and wrong information on those social platforms.

Most of the time due to the lack of verified news sources and fact-checkers on social media platforms in Sri Lanka social media users are failed to identify false information in their news feeds. As a consequence of that, people are sharing those news stories without checking and this leads to spreading a lot of misinformation through social media platforms in Sri Lanka during the year of 2019. For example, after the Easter Sunday attacks in Sri Lanka government decided to block social media access due to alleged false information circulating on social media occurring lot of misunderstanding between people and religions('Sri Lankan Government Blocks Social Media Access Over Alleged Fake News', 2019). Not only that, before and after the presidential election in Sri Lanka in 2019, a lot of false information has also created and spread through social media platforms to change the mindset and opinion of people(Wong, 2019).

Many instances have recorded from different countries regarding the widespread impact of false information on social media platforms. During the US presidential election in 2016, "Pizzagate" fake news is widely spread on Twitter by creating more than one million tweets('Pizzagate

conspiracy theory’, 2019) and during the Gubernatorial campaign in Jakarta back in 2016 governor, Ahok sentenced to two years in prison for criticizing a verse of Quran(Lamb, 2017).

These incidents have clearly indicated that a strong need emerges to develop a fact-checking platform to overcome this problem. From this study, we propose a mobile platform called ‘SherLock’ that can use as a platform for fact-checking on social media using a CNN, RNN-LSTM based hybrid model(Goonathilake and Kumara, 2020) and including many other features such as daily news updates, news reporting and social media trends etc.

### Literature Review

Hoaxy(Shao *et al.*, 2016) is an online tool that can collect and tracks misinformation. Then it can visualize that misinformation by using the technologies like web scraping, web syndication, Twitter API and RSS parser. FakeNewsTracker(Shu, Mahudeswaran and Liu, 2019) is another tool to collect and visualize false news on social media using some of the deep learning mechanisms like LSTM, auto-encoder etc. Using Hoaxy API, a tool called ‘dEFEND’ has developed to provide a news propagation network including trending news and top claims. It also can provide some explainable insight into user comments on Twitter. News Verify(*Real-Time News Certification System on Sina Weibo*, 2019) has developed to detect the credibility of news using the techniques like feature extraction, sentiment analysis and web crawling etc. Authors (Conroy, Rubin and Chen, 2015) have developed an extension for both Chrome and Mozilla browsers called ‘B.S. Detector’ to check unreliable sources against a manually compiled list of domains.

According to (Ahmed, Traore and Saad, 2017) they used machine learning techniques to detect false information and

proposed a method using word-based n-grams. Authors (Aldwairi and Alwahedi, 2018) have proposed a method using WEKA machine learning classifiers. Fake News Pattern Detector(*Fake News Patterns Detector*, 2019) used a deep learning network to detect the patterns in fake news by applying several techniques like CNN, word2vec word embeddings and feature extraction etc. TRACEMINER(Wu and Liu, 2018) also used an LSTM-RNN model to provide high classification accuracy on real-world data sets. Authors (Kaliyar, 2018) have proposed several deep learning networks to detect false information. Rather than using classical models, they proposed a combination of neural networks to use in fake news detection.

Figure 1 represents some of the related software and comparison of their features. From the proposed mobile platform covers all the features mentioned below.

Software	Filter Fake News Articles	Send Alerts about Fake News and Breaking News	Check credibility and validity of social media posts	Add crowdsource fact-checker	Leverage app usage statistics for users
Oigetit	✓	×	×	×	×
WatchDog	×	✓	×	×	×
Fact-Bounty	×	×	×	✓	✓
Listle	×	✓	×	×	×
SherLock	✓	✓	✓	✓	✓

Figure 1. Comparison of features in related software

### Design and Implementation

#### A. The High-Level Architecture of the System

The proposed system consists of several parts including MVVM architecture which represents the model-view-view-model pattern of the mobile application. The mobile application has developed including many features namely, daily news updates, fact-checking, news reporting, social media news trends and daily COVID19 report. Then cloud database has used by including several crud

operations for each feature of the mobile app. REST APIs and web scraping method have used to collect information from different news sources to build the hybrid deep learning model. After that, the same cloud database has used to store the hybrid deep learning model.

Figure 2 represents the overall system architecture of the proposed system. As for the front-end of the proposed system developed a mobile application including the above-mentioned features. And for the back-end of the proposed system used a cloud database to store the hybrid deep learning model and included several crud operations according to the features of the mobile application.

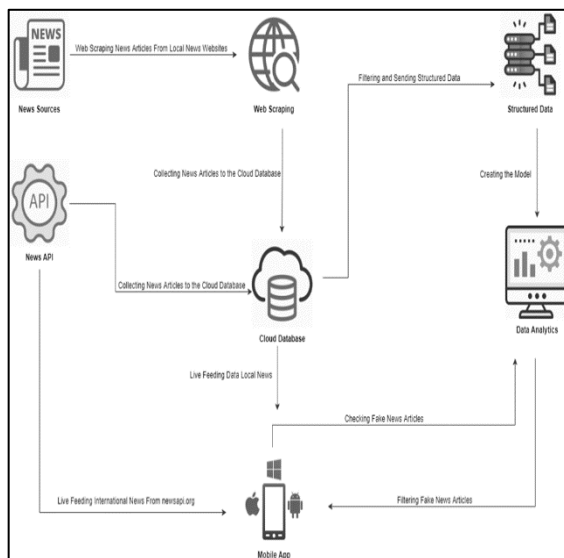

Figure 2. The overall system architecture of the proposed system

### B. Software Process Model of the System

The incremental software process model is consisted of breaking down requirements into subsystems and modules (“Software Engineering | Incremental process model”, 2018). Therefore, the proposed system applied a software process model as Incremental.

Figure 3 indicates three subsystems of the main feature of the proposed solution. The first subsystem includes data collection part to develop deep learning model and next

subsystem includes checking the social media posts using the hybrid deep learning model. And the final subsystem is about checking the status of the posts using the mobile application. If it is verified news it represents using green colour and if it is fake news it represents in red colour.

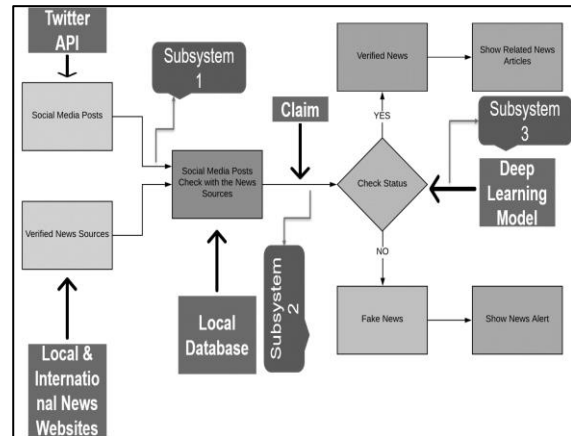

Figure 3. Software process model for the main feature

### C. Design Diagrams for Proposed System

All the design diagrams of the proposed system have drawn using an open-source online tool called ‘Lucidchart’ (Online Diagram Software & Visual Solution, 2020).

High-level use case diagram includes different use cases of the proposed mobile application. Target stakeholders for the proposed mobile application are news agencies, daily news reporters, daily newsreaders and social media users of Sri Lanka. News agencies have the admin authority of the mobile application and other stakeholders have provided with different features according to their preferences.

Figure 4 represents the use cases of the proposed mobile application for a common user and administrator.



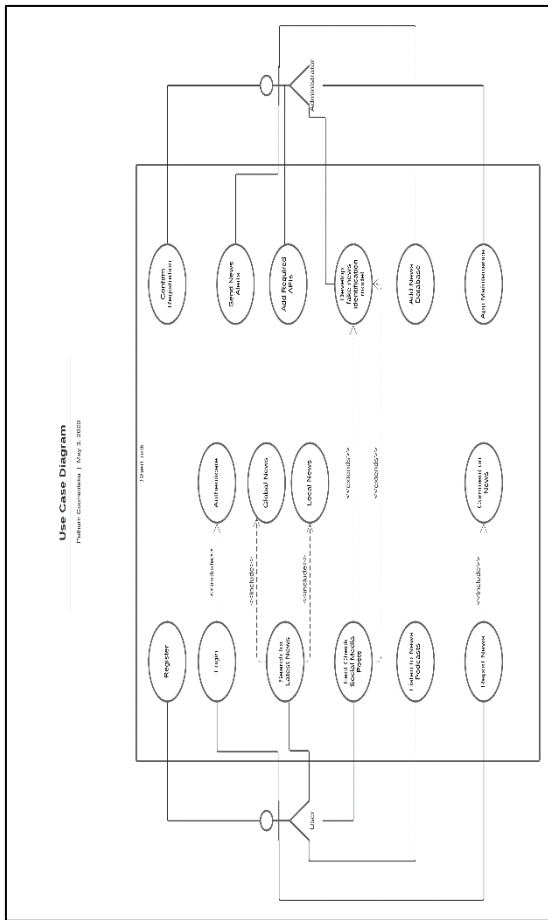

Figure 4. High-level use case of proposed mobile application

The class diagram represents the static structure of the system by describing the attributes, methods and the relationship among them ('Class Diagrams - Learn Everything About Class Diagrams', 2020).

Figure 5 indicates the class diagram of the proposed system by describing main classes like the user, news, model etc. And some of the methods like login, register, report news etc. It also includes the attributes of the system as well.

The entity-relationship diagram indicates the main entities of the proposed mobile application after doing several normalization steps.

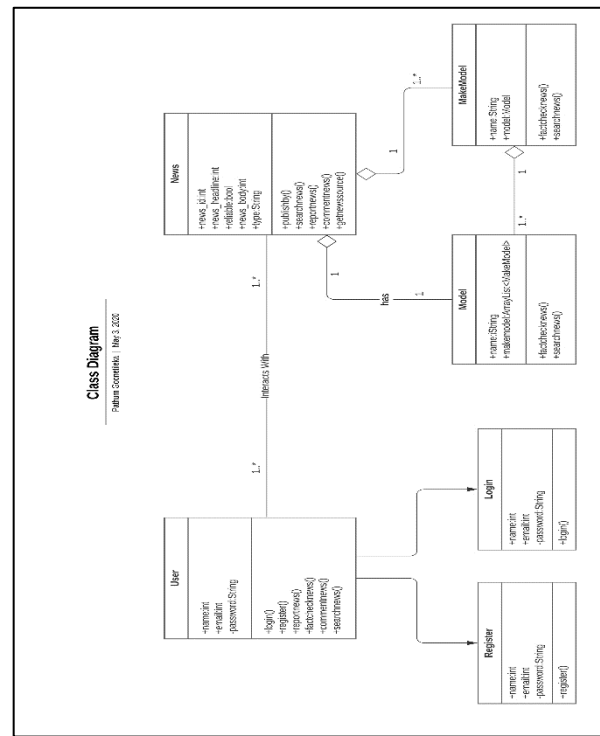

Figure 5. Class diagram for the proposed system

Figure 6 represents the entity-relationship diagram of the database by describing the entities and their main attributes.

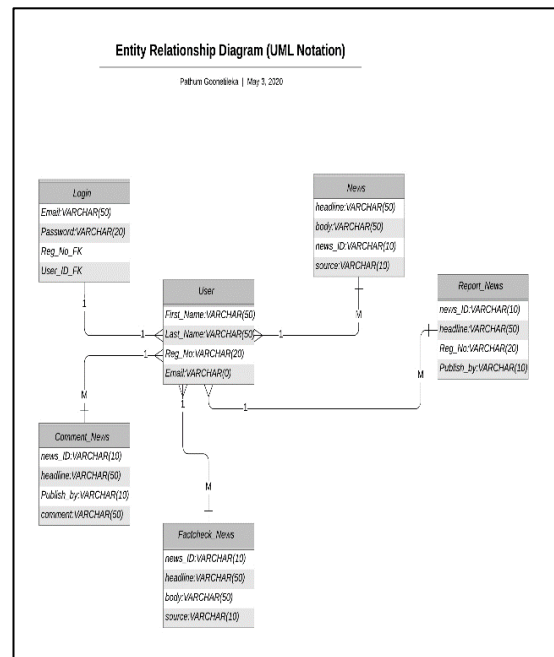

Figure 6. Entity-relationship diagram for the proposed system

Sequence diagrams interact with showing object interactions which are arranged according to time sequence ('Sequence Diagrams - What is a Sequence Diagram?',

2020). Figure 7 represents the sequence diagram for the proposed system by showing the interactions between main objects namely, mobile app, deep learning model and database.

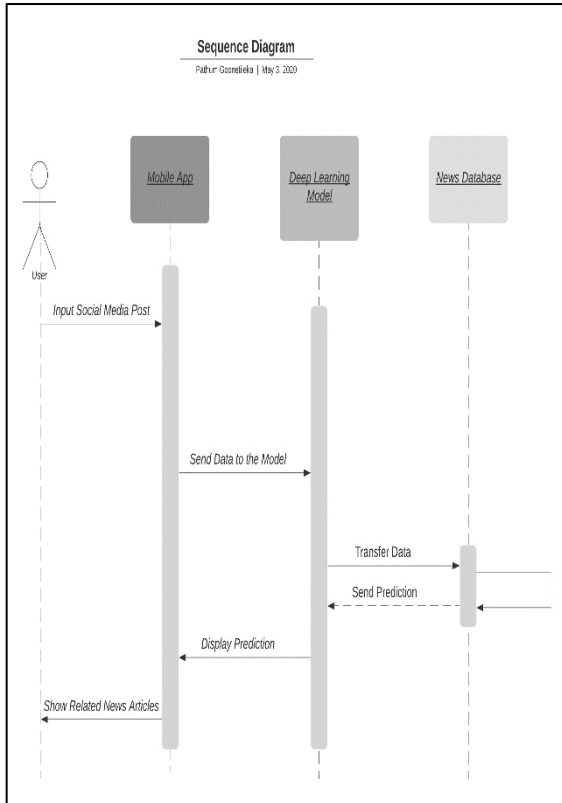

Figure 7. Sequence diagram for the proposed system

#### D. Design of the Proposed Mobile Application

Design of the proposed mobile application includes several screens of the mobile app such as onboarding screen, registration screen, login screen, home screen and other feature-wise screens etc. But here mentioned only the screens of the main features of the mobile application.

Figure 8 represents the home screen of the mobile application which shows the latest global news around the world by categorizing news for business, entertainment, health, science and sports etc. If the user wants to know more information about particular news they can click on the news article and it navigates to a URL where it includes more information about the news article.

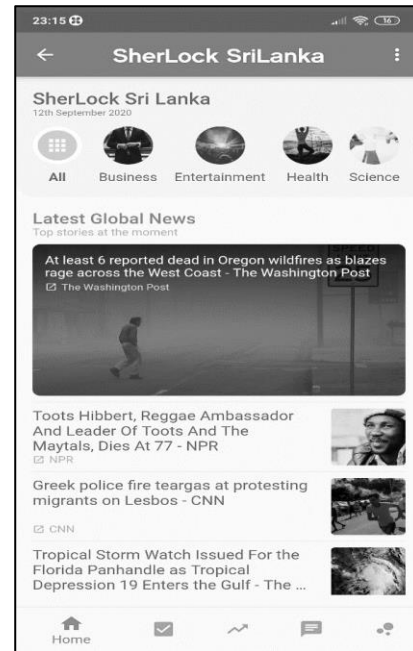

Figure 8. The latest global news screen

Figure 9 indicates the latest news trending on Twitter and the latest fact checks from the websites like AFP news. If the user wants to know more information like the above screen they can click and navigate to find more information on each news.

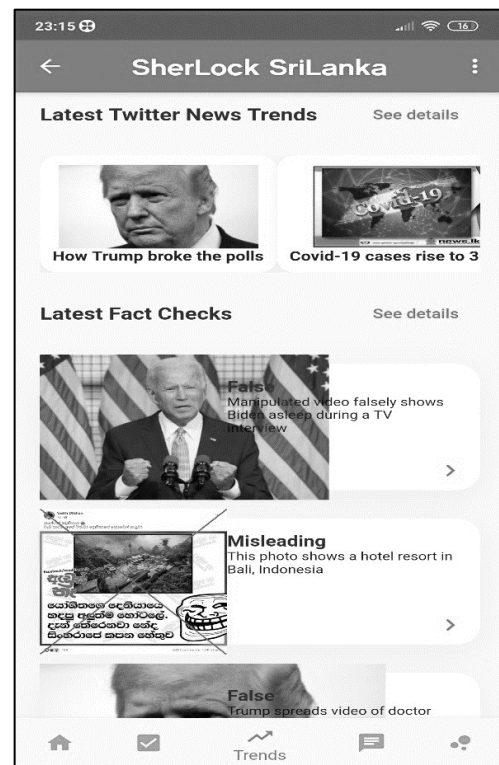

Figure 10 represents the news reporting screen where news reporters can report the news to the platform



Figure 10. News reporting screen

Figures 11 represents the daily COVID-19 report screen where users can see information according to their language preferences. Localization has added to the feature for languages English, Sinhala and Tamil.

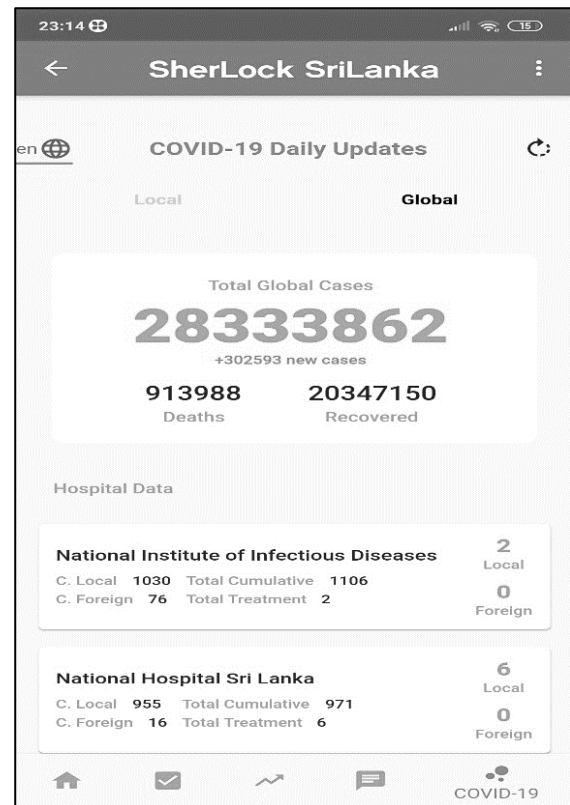

Figure 11. COVID-19 updates using English language

Figures 12 represents the daily COVID-19 report screen in the Sinhala language.



Figure 12. COVID-19 updates using Sinhala language

Figure 13 represents the main feature of the mobile application which is about the fact-

checking of social media posts. User can input the text of the social media post and it classifies as verified news or fake news from the hybrid model. As an example, if the user inputs the text as 'Dalada Maligawa website comes under cyber-attack' then from the hybrid model it checks and gives a message as verified news by showing the text in green colour. If the user inputs a message like 'All the universities and schools remain closed for two months due to the coronavirus outbreak in the country' then from the hybrid model it labels as a fake one by showing the red colour with the text. This screen is used to fact-check the social media posts using the CNN, RNN-LSTM based hybrid model.

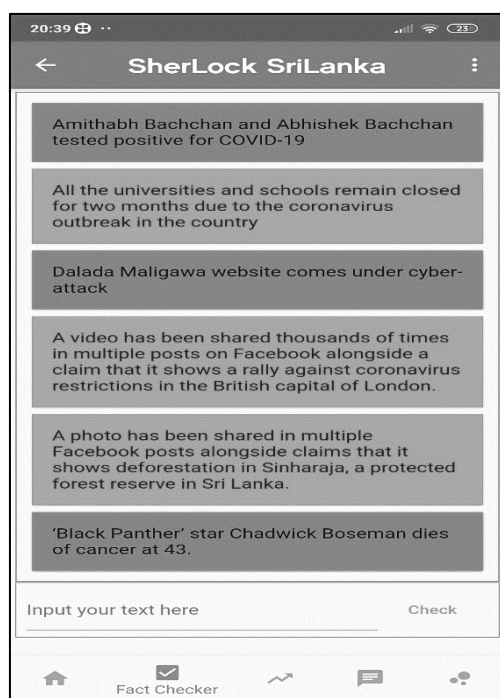

Figure 13. Fact-checking screen

## Technology Adopted

### A. Use Flutter as Front-End Framework

The reason for using Flutter('Flutter - Beautiful native apps in record time', 2020) as the front-end framework of the proposed mobile application is to build beautiful, natively compiled mobile application for both Android and IOS from a single codebase.

The best thing about Flutter is free and open-source by providing native interfaces. When compare with other mobile development frameworks Flutter has a fast development methodology by providing some easy infrastructure for developers.

### B. Use Firebase as Back-End Framework

For the proposed system, had to deal with a lot of unstructured data types. Therefore, choose Firebase(Firebase, 2020) as the back-end framework of the proposed system. Firebase authentication has used to authenticate users from the login screen. And Firebase Database and Firestore have used to store news reports. Then Firebase Storage has used to store images of the news reports. Finally, used Firebase Machine Learning to store the hybrid deep learning model.

### C. Use Scrapy to collect data

Before building the hybrid deep learning model collected data from different news sources using the web scraping method. For that, Scrapy('Scrapy | A Fast and Powerful Scraping and Web Crawling Framework', 2020) which is an open-source web scraper is used.

### D. Use TensorFlow to build the model

The hybrid deep learning model has used TensorFlow(Keras | TensorFlow Core, 2020) to build the model and Python as the programming language. Because it has rich support to both front-end and back-end frameworks and also it has a flexible and comprehensive ecosystem.

### E. Use GitHub to maintain the project

For the proposed system, GitHub(Build software better, together, 2020) used to maintain the project repository. And also GitHub Actions(Features • GitHub Actions, 2020) used to build the CI/CD(Continuous Integration/Continuous Delivery) pipeline and deploying the mobile application.

### F. Use IntelliJ IDEA as a platform to build the project

IntelliJ IDEA(IntelliJ IDEA: The Java IDE for Professional Developers by JetBrains, 2020) has used as the platform to develop the mobile application because it has rich support to both front-end framework Flutter and back-end framework Firebase as well.

G. Use PyCharm as a platform to build the model

PyCharm(PyCharm: the Python IDE for Professional Developers by JetBrains, 2020) has used as the platform to build the data collection method. After that added some of the Natural Language Processing techniques like tokenization, pre-processing and word embeddings etc. Finally, build the hybrid model after doing the above steps.

Figure 14 represents overall technology map of the system.

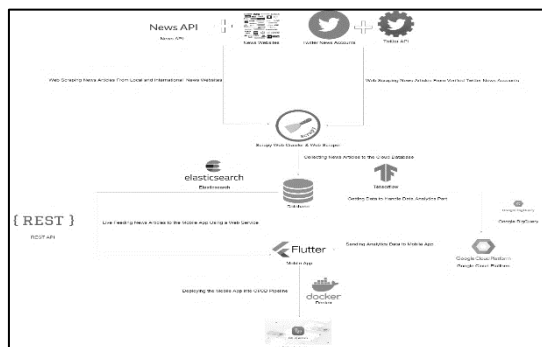

Figure 14. Technology map for the proposed system

H. Use Kaggle kernels/Google Colab to run the model

The hybrid deep learning model needed more power to execute with the dataset size and the complexity of the model. Therefore, choose Kaggle kernels(Kaggle: Your Home for Data Science, 2020) and Google Colab(Google Colaboratory, 2020) cloud environments with built-in TPUs to run the model.

### Testing and Evaluation

Test driven development methodology has used throughout the project. Different automated tests help to ensure the performance of the mobile app. Unit tests have used to test the functions of the mobile app. And widget tests have applied on UIs to

test the widgets of the mobile app. After that, integration tests and end-to-end tests have used to test the complete mobile app. GitHub Actions CI/CD pipeline used to run tests automatically when pushing new code changes to the repository.

As for the evaluation of the mobile application, Docker(Empowering App Development for Developers | Docker, 2020) has used to enhance the performance of the app. Then app bundle packages have applied to reduce the size of the app. The proposed mobile application is compatible on both Android and IOS versions when using Flutter as the front-end framework.

### How System Works

The proposed mobile application has several main features such as daily news updates, fact-checking, news reporting, social media news trends and daily COVID19 report. First, the user needs to register to the system by providing correct details. Only the admin user has full access to all features of the mobile app. Other users have access to specific defined features only. Which means according to the target stakeholders, the news agency has the full access of the system and other users like daily news reporters, daily newsreaders and social media users can access specific defined features only. As an example, daily news reporters have the access to news reporting screen but other two users do not have access to that screen. For restricting the access for specific features, role-based authorization has used to manage users. Let's see how the main features of the proposed mobile application work.

#### A. Latest Global News Feature

After logging to the system by giving correct credentials user navigates to the home page where user able to see the latest global news articles. Users can navigate between different categories of news according to their preferences. This screen shows the

latest global news around the world by categorizing news for business, entertainment, health, science and sports etc. If the user wants to know more information about particular news they can click on the news article and it navigates to a URL where it includes more information about the news article. This feature is visible to all the users. News API(*News API - A JSON API for live news and blog articles*, 2020) has used here to fetch live news articles to the mobile application using a JSON API.

#### B. Fact-Checking Feature

After navigating to the home screen user able to see the bottom navigation bar. From that, the user can shift between different features. After clicking the fact-checking feature user navigates to a screen where they can fact-check social media posts using the CNN, RNN-LSTM based hybrid model. User can input the text of the social media post and it classifies as verified news or fake news from the hybrid model. As an example, if the user inputs the text as 'Dalada Maligawa website comes under cyber-attack' then from the hybrid model it checks and gives a message as verified news by showing the text in green colour. If the user inputs a message like 'All the universities and schools remain closed for two months due to the coronavirus outbreak in the country' then from the hybrid model it labels as a fake one by showing the red colour with the text. The hybrid model has an accuracy of 92% and it includes several deep learning mechanisms. CNN, RNN-LSTM based hybrid model ables to capture high-level features and long-term dependencies from the input text. For more information about the CNN, RNN-LSTM hybrid model refers to the following study which is done by the authors(Goonathilake and Kumara, 2020). This feature is accessible only for social media users to check the validity and credibility of the social media post. TensorFlow used to develop the hybrid model then Firebase machine learning used

to store the model and REST APIs(*REST APIs: An Introduction / IBM*, 2020) used to interact with the model with front-end framework Flutter.

#### C. Latest Twitter News Trends and Latest Fact-Checkings Feature

This feature is visible for all the users. From this feature, users can get to know about the latest Twitter trends and latest fact-checkings. If the user wants to know more information about particular news trends they can click on the news article and it navigates to the post where it includes more information about the trending news articles. Twitter API(*Use Cases, Tutorials, & Documentation*, 2020) is used to get the latest Twitter trends and web sites like AFP Fact Check used to get the latest fact checkings using REST APIs.

#### D. News Reporting Feature

If the logged-in user is a news reporter they can easily navigate to the news reporting feature from the bottom navigation bar. News reporters can upload news to the system by providing the correct details such as reporters name, the title of the news, description of the news and related photo of the news. This feature is only visible to news reporters only. Firebase Database and Firestore has used to store news reports and Firebase storage has used to store related photos of the news articles.

#### E. Daily COVID-19 Report

User can navigate to this feature from the bottom navigation bar by clicking the last item of it. This feature represents the daily COVID-19 updates in Sri Lanka and the world. Here, the user can see information according to their language preferences. Information mainly includes total global and local cases, total deaths, total recovered and hospital data. Localization has added to the feature for languages English, Sinhala and Tamil. This feature also visible to all the

users. REST APIs have used to fetch live updates to the mobile application and Google Translate has used to add the localization.

### Conclusion and Future Works

In conclusion, we have shown that the proposed mobile application is an efficient solution for Sri Lanka. Because it provides many features such as daily news updates, fact-checking, news reporting, social media news trends and daily COVID19 report. And the main feature of fact-checking is more important for daily social media users to find between real and fake news articles as well.

As for future work, the suggested mobile application hope to launch as a complete system to the public with versions for both Android and IOS. With that, hope to publish this mobile application on the Android Play Store and Apple App Store.

### Acknowledgment

The authors of this research paper would like to acknowledge the tremendous support given by the supervisors for their assistance and feedback on this research paper.

### References

Ahmed, H., Traore, I. and Saad, S. (2017) 'Detection of Online Fake News Using N-Gram Analysis and Machine Learning Techniques', in Traore, I., Woungang, I., and Awad, A. (eds) *Intelligent, Secure, and Dependable Systems in Distributed and Cloud Environments*. Springer International Publishing (Lecture Notes in Computer Science), pp. 127–138.

Aldwairi, M. and Alwahedi, A. (2018) 'Detecting Fake News in Social Media Networks', *Procedia Computer Science*, 141, pp. 215–222. doi: 10.1016/j.procs.2018.10.171.

*Build software better, together* (2020) *GitHub*. Available at: <https://github.com> (Accessed: 13 September 2020).

'Class Diagrams - Learn Everything About Class Diagrams' (2020). Available at: <https://www.smartdraw.com/class-diagram/> (Accessed: 13 September 2020).

Conroy, N. J., Rubin, V. L. and Chen, Y. (2015) 'Automatic deception detection: Methods for finding fake news', *Proceedings of the Association for Information Science and Technology*, 52(1), pp. 1–4. doi: 10.1002/pr2.2015.145052010082.

*Empowering App Development for Developers / Docker* (2020). Available at: <https://www.docker.com/> (Accessed: 14 September 2020).

*Fake News Patterns Detector* (2019). Available at: <http://fakenews.mit.edu/> (Accessed: 28 October 2019).

*Features • GitHub Actions* (2020) *GitHub*. Available at: <https://github.com/features/actions> (Accessed: 13 September 2020).

*Firebase* (2020) *Firebase*. Available at: <https://firebase.google.com/> (Accessed: 13 September 2020).

'Flutter - Beautiful native apps in record time' (2020). Available at: <https://flutter.dev/> (Accessed: 13 September 2020).

*Google Colaboratory* (2020). Available at: <https://colab.research.google.com/notebooks/> (Accessed: 13 September 2020).

Goonathilake MDPP and Kumara PPNV (2020) 'CNN, RNN-LSTM Based Hybrid Approach to Detect State-of-the-Art Stance-Based Fake News on Social Media', in *2020 20<sup>th</sup> International Conference on ICT for emerging regions (ICTer)*.

*IntelliJ IDEA: The Java IDE for Professional Developers by JetBrains* (2020). Available at: <https://www.jetbrains.com/idea/> (Accessed: 13 September 2020).

*Kaggle: Your Home for Data Science* (2020). Available at: <https://www.kaggle.com/> (Accessed: 13 September 2020).

Kaliyar, R. K. (2018) 'Fake News Detection Using A Deep Neural Network', in *2018 4th International Conference on Computing Communication and Automation (ICCCA)*. *2018 4th International Conference on Computing Communication and Automation (ICCCA)*, pp. 1–7. doi: 10.1109/CCAA.2018.8777343.

*Keras / TensorFlow Core* (2020) *TensorFlow*. Available at:

<https://www.tensorflow.org/guide/keras>  
(Accessed: 31 May 2020).

Lamb, K. (2017) 'Jakarta governor Ahok sentenced to two years in prison for blasphemy', *The Guardian*, 9 May. Available at: <https://www.theguardian.com/world/2017/may/09/jakarta-governor-ahok-found-guilty-of-blasphemy-jailed-for-two-years> (Accessed: 8 September 2020).

*News API - A JSON API for live news and blog articles* (2020) *News API*. Available at: <https://newsapi.org> (Accessed: 13 September 2020).

*Online Diagram Software & Visual Solution* (2020) *Lucidchart*. Available at: <https://www.lucidchart.com> (Accessed: 13 September 2020).

'Pizzagate conspiracy theory' (2019) *Wikipedia*. Available at: [https://en.wikipedia.org/w/index.php?title=Pizzagate\\_conspiracy\\_theory&oldid=917379104](https://en.wikipedia.org/w/index.php?title=Pizzagate_conspiracy_theory&oldid=917379104) (Accessed: 28 October 2019).

*PyCharm: the Python IDE for Professional Developers by JetBrains* (2020). Available at: <https://www.jetbrains.com/pycharm/> (Accessed: 13 September 2020).

*Real-Time News Certification System on Sina Weibo* (2019). Available at: <https://dl.acm.org/citation.cfm?id=2742571> (Accessed: 28 October 2019).

*REST APIs: An Introduction | IBM* (2020). Available at: <https://www.ibm.com/cloud/learn/rest-apis> (Accessed: 13 September 2020).

'Scrapy | A Fast and Powerful Scraping and Web Crawling Framework' (2020). Available at: <https://scrapy.org/> (Accessed: 31 May 2020).

'Sequence Diagrams - What is a Sequence Diagram?' (2020). Available at: <https://www.smartdraw.com/sequence-diagram/> (Accessed: 13 September 2020).

Shao, C. *et al.* (2016) 'Hoaxy: A Platform for Tracking Online Misinformation', in *Proceedings of the 25th International Conference Companion on World Wide Web*. Republic and Canton of Geneva, Switzerland: International World Wide Web Conferences Steering Committee (WWW '16

Companion), pp. 745–750. doi: 10.1145/2872518.2890098.

Shu, K., Mahudeswaran, D. and Liu, H. (2019) 'FakeNewsTracker: a tool for fake news collection, detection, and visualization', *Computational and Mathematical Organization Theory*, 25(1), pp. 60–71. doi: 10.1007/s10588-018-09280-3.

'Software Engineering | Incremental process model' (2018) *GeeksforGeeks*, 28 May. Available at: <https://www.geeksforgeeks.org/software-engineering-incremental-process-model/> (Accessed: 13 September 2020).

'Sri Lankan Government Blocks Social Media Access Over Alleged Fake News' (2019) *Reason.com*, 22 April. Available at: <https://reason.com/2019/04/22/sri-lankan-govt-blocks-social-media-access-over-alleged-fake-news/> (Accessed: 12 September 2020).

*Use Cases, Tutorials, & Documentation* (2020). Available at: <https://developer.twitter.com/en> (Accessed: 13 September 2020).

Wong, J. C. (2019) 'Sri Lankans fear violence over Facebook fake news ahead of election', *The Guardian*, 12 November. Available at: <https://www.theguardian.com/world/2019/nov/11/facebook-sri-lanka-election-fake-news> (Accessed: 12 September 2020).

Wu, L. and Liu, H. (2018) 'Tracing Fake-News Footprints: Characterizing Social Media Messages by How They Propagate', in *Proceedings of the Eleventh ACM International Conference on Web Search and Data Mining*. New York, NY, USA: ACM (WSDM '18), pp. 637–645. doi: 10.1145/3159652.3159677.

## Author Biographies



Mr. MDPP Goonathilake is a software engineering undergraduate at Department of Computer Science, Faculty of Computing, KDU.



Mr. PPNV Kumara is a senior lecturer at the Department of Computer Science, Faculty of Computing, KDU



## Ontology-Driven Decision Making for Subfertility of Female

Y Thenuka#, S Vasanthapriyan, K Banujan

*Department of Computing & Information Systems, Faculty of Applied Sciences, Sabaragamuwa University of Sri Lanka, Belihuloya, Sri Lanka*

#thenuka94@gmail.com

**Abstract** Failure to conceive after 12 months of unprotected and regular sexual intercourse is called as subfertility. In the medical domain, at first, males are checked for subfertility causes. Then, females need to check for their subfertility cause. Here, female subfertility is a vast area than male subfertility. So, it's difficult to take decision making. So, ontology will help to make decisions to diagnose the cause and treatment method for causes in subfertility. Subfertility of female Information collected from the Doctors, Medical Students, and Books in the very first stage. After that, started to develop ontology and implemented using Protégé OWL Ontology Editor 5.5 was used for this purpose. Finally, the developed ontology was evaluated in two ways; by using inbuilt tools and by ontology experts as an iterative approach. This approach to subfertility of female ontology can support the medical students, doctors moreover their assistants to enhance their knowledge and helpful in decision-making

**Keywords** subfertility, ontology, decision support

### Introduction

Natural conception occurs after ovulation, the egg usually lives up to 24 hours. After ejaculation, sperm can survive up to seven days in the genital tract and sometimes even longer. Erection, penetration, Ejaculation & deposit in the right place, no cervical hostility, normal uterus, normal fallopian tubes, and normal ovulation are important for successful conception (Stanford, et al.,

2002). Doctors who counsel women for preconception concerns are in the best position to provide advice to couples regarding the optimal timing of intercourse to achieve pregnancy. Conception is feasible from intercourse beginning about 5 days before ovulation extending through the day of ovulation (Stanford, et al., 2002). (Joffe & Li, 1994).

A female's best reproductive years are in her age of 20s. Fertility gradually decreases in the age of 30s, particularly after age 35. Age of 30 female has a 20% chance of getting pregnant when each month that she tries, for a healthy fertile. A woman's chance is less than 5% per cycle by age 40. As a result, fewer than 5 out of every 100 women are expected to be successful each month of conceiving (Larsen, 2005). A Female's fertility period depends on menstrual cycle length. Alcohol, smoking, body weight, temperature & sperm counts, prescribed drug use are some factors that affect fertility (Vander Borgh & Wyns, 2018).

A common definition of subfertility is needed for the better management of subfertility (Gnoth, et al., 2005). Subfertility is a disease that general term describes the failure to get clinical pregnancy after twelve months of unprotected & regular sexual intercourse (Vander Borgh & Wyns, 2018). Ovulatory Problem, Tubal Disorders, Uterine Abnormalities, Endometriosis, and in advance female's age are general causes of subfertility in females (Adamson, 2003). 80% of pregnancies occur in the first six cycles with continuous intercourse in the

fertile phase. After that, doctors assume that in the remaining 20% of 10% of couples have serious subfertility. After calculating the total 12 unsuccessful cycles of continuous sexual intercourse, birth rates of persons will come to 55%. Thereafter 48 months, zero percentage chance to conceive is called infertility. Those infertility people are about 5% of people. Appropriate circumstances after six months of the unsuccessful cycle help to reduce the infertility of couples. It helps to avoid the age problem of conceiving. Couples with a good prognosis mostly encouraged to wait to conceive because even with the treatment they do not have a better chance of conceiving (Gnoth, et al., 2005).

Ontology provides a structured view of domain knowledge and acts as a repository of concepts in the domain (Walisadeera, et al., 2013). Besides, ontology is made machine-interpretable using knowledge representation techniques and therefore, can be used for establishing a common conceptualization to facilitate store, share, retrieve, decision making, and representing knowledge. Further, domain ontologies are highly powerful knowledge representation models for presenting and describing a set of relevant domain-specific concepts and their relationships informally. (Vasanthapriyan, et al., 2017).

Sometimes, this concept is expressed by using various terminologies because of the incomplete, unstructured, general nature, and different formats of the information and the knowledge are not reaching everybody (Haghigh, et al., 2013). Further, computers need to understand the meaning or semantics of the information clearly. The semantic web enables this understanding of computers. Ontologies are a powerful mechanism for representing knowledge presented in the semantic web. Therefore, ontology can be used to find a response to queries within a specified context in the

domain of subfertility of females (Vasanthapriyan & Banujan, 2019).

This work aims to contribute to decision making in the female subfertility treatment in hospitals by developing an ontology-driven solution that organizes, describes, and helps to decision making clearly in the related knowledge also can get knowledge for medical students by developing an ontology-driven solution that describes all the treatment method from base to the top level. This would assist the doctors and their assistants in the gynaecological department in hospitals to decision making to find the causes and treatment methods.

The objective of this paper is the presentation of a new ontology for decision making in the subfertility domain. This paper is organized as follows; Section 2 describes the methodology and experimental design, section 3 provides the results of the ontology domain, section 4 presents the evaluation and methods of the proposed system and section 5 contains the conclusion and future work.

### **Methodology and Experimental Design**

Modeling ontology is a time-taking process and it requires appropriate tools. Further, constructing a domain ontology from the beginning is a complicated task. After reviewing all the methodologies in literature, Gruninger and Fox's methodology (Gruninger & Fox, 1995) was used for the ontology modeling of female subfertility (Vasanthapriyan & Banujan, 2019). The methodology for modeling the ontology for female subfertility is shown in Figure 1.

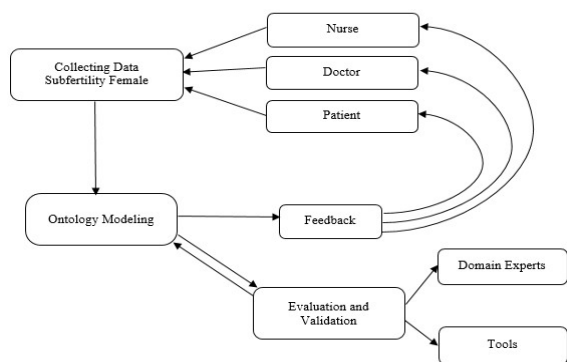

Figure 1. High-level methodological framework

We chose Gruninger and Fox’s methodology (Gruninger & Fox, 1995) as it gives a formal approach for ontology designing and it gives a framework to the developed ontology for the evaluation. It mainly focuses on building ontology-based on first-Order Logic (FOL) by providing strong semantics. Web Ontology Language was used for modeling ontology. It was used for formalizing relationships between concepts. OWL is chosen because it is a mark-up language with a formal, logical semantic. Data type properties link to an individual eXtensible Mark-up Language (XML) Schema Data type value or a Resource Description Framework (RDF) literal. In other words, it describes relationships between data values and individuals. A data type property can also be used in a restriction to relate individuals to members of a given data type primitive FOL. (Vasanthapriyan & Banujan, 2019).

The focus was on the female subfertility decision-making process because this subfertility problem plays a major role in most of the couples. Grounded theory was used for data collection in this field. One Doctor with extensive knowledge of subfertility, five final year medical students who are studying in various universities, and the books provided by the medical students were used to get the domain knowledge in the subfertility area. After interviewing them, subfertility treatment decision-making problems were identified. The Competency Questions (CQs) were developed after the

collection of information from the interviewees. The ontology could be capable of answer the set of questions that is called CQs by using its axioms. CQs work as a requirement specification of the female subfertility ontology. Ontology tries to answer competency questions (Indika Walisadeera, et al., 2014) (Choraś, et al., 2010). Some of them are shown in Table 1. Ontology hierarchy developed by using the ontology knowledge and using CQ Questions & answers. Figure 2 describes the high-level hierarchy of ontology of subfertility by using the competency questions which is developed to help the decision-making process of the subfertility of the female.

The contents of the ontology need to be validated after designing the ontology. Otherwise, incorrect relationships in the ontology will spread errors to subsequent design and implementation activities in future work. The ontology model was evaluated by ontology experts and all the pitfalls were planned to rectify by their comments. Here, OOPS! The evaluation used to find the pitfalls and corrected. CQs were evaluated using the DL expressions. The DL query tool is available in the Protégé- OWL Ontology Editor 5.5 was used for this purpose. Description Logic (DL) was used for this work because OWL2 Web Ontology Language is used for modeling the ontology. DL is a decidable fragment of FOL and is more expressive than primitive FOL. The greatest advantage of DL models is not representing the information model only but reasoning with the model. The meaning of the DL is unambiguous and precise and is capable to check the consistency of any entire ontology model. DL query checked the accuracy and quality of the ontology by using the Fact++ Reasoner and SPARQL Queries also used to evaluate.

Table 1. Some Competency Question

Subfertility Information	Female's Subfertility (i.e) Competency Question	Generalizing Contextualized Information
What is the first thing that has to do with the doctor when treating a patient?	What is the Order of Collecting Medical History? What are the categories collect under present medical history? What are the Menstrual History collected in Gynaecological history? What are the system Enquiry in gynaecological history?	What are the details collect under all histories?
How can doctors find causes of subfertility using examinations?	What are the various ovulatory disorder? What are the disorder in tubal? What are the examination used to find every disorder?	What are the subfertility major subfertility causes?
What are the treatment for subfertility causes?	What are the treatment used for ovulation disorder? What are the treatment used for every ovulation disorder? What are the tubal surgeries done for tubal disorders? What is the order of treatment if previous treatment is not successful? What are the medical and surgical treatment for uterine disorders? What are the treatments and what is the order of unexplained factor treatment? What are the other treatments for subfertility problem?	What are the main phases in treatment for subfertility?

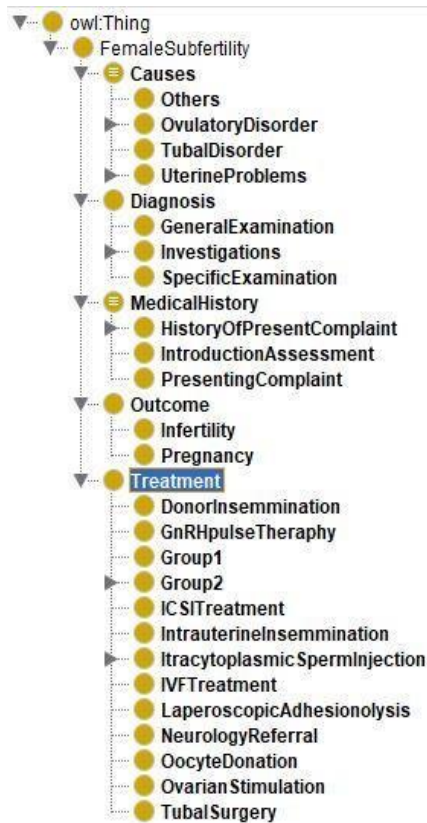

Figure 2. High-level Hierarchy

## Results

Ontology for subfertility was created using Protégé Ontology Editor 5.5. This Ontology was redeveloped after the comments of doctors and medical students' evaluation of the ontology pitfalls. Part of the Female Subfertility Ontology shown in Figure 3. Some DL queries and answers shown in Table 2.

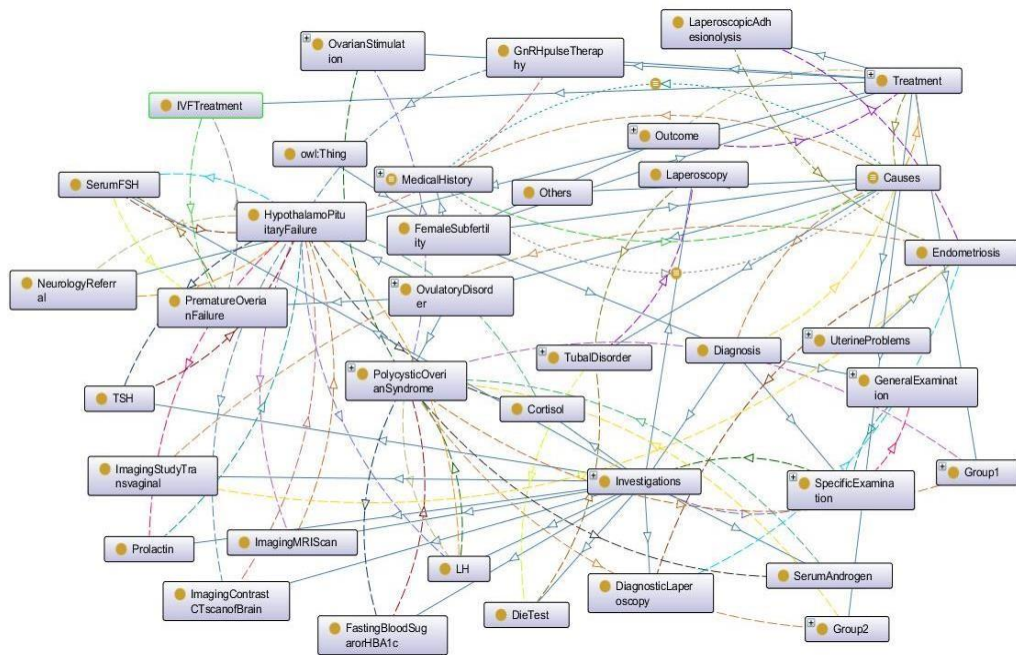

Table 2. DL Queries and Answers

Competency Questions	DL Query	Answers
What are the treatment method for Tubal Disorder Cause?	TubalSurgery and hasSurgeries only TubalSurgery	<ul style="list-style-type: none"> <li>• Labaroscopic_Tubal_Surgery</li> <li>• Surgery_for_hydrosalpinges</li> <li>• Tubal_catheterisation_or_cannulation</li> <li>• Tubal_microsurgery</li> </ul>
What are the medical history that helps to find Tubal Disorder?	TubalDisorder and is select some MedicalHistory	<ul style="list-style-type: none"> <li>• Scar_Tissue</li> <li>• Pelvic_Inflammatory_Disease</li> <li>• History_of_Gonorhea_or_Chlaymydia</li> </ul>

## Discussion

Female Subfertility is the vast area in the gynaecological part in the medical area that mainly depends on the experience and knowledge of the doctors. All the important areas are covered in the ontology, which is used to decision making in the diagnosis of the causes and treatment for the causes. An ontological approach is used to represent the needed part is covered in the research.

Designing this type of ontology is not a small task, because we need to gain vast domain knowledge and this domain is new to the author. Therefore, the author needs to read many books in this field and have to get knowledge from doctors and medical students. In this paper, we have clearly explained how ontology designed,

implemented in the protégé, and developed the ontology to organize domain knowledge to take particular decisions in treatment.

The evaluation (Ferenc, 2016) and validation have been done separately. FaCT++ reasoner is used to validating the accuracy and quality of developed ontology. Protégé-OWL Ontology Editor 5.5 has the FaCT++ reasoner as an inbuilt tool. Moreover, we used OOPS! which is a web-based tool. Figure 4 describes the OOPS Evaluation Results. All the Critical, Important errors were identified using this evaluation and all were rectified. Ontology expert’s massive help used to evaluate the ontology by testing the false feeding of the terms and relationship we used. Ontology was redeveloped by the ontology experts’

responses, comments, and suggestions that. Even though there are some works on a decision support system such as Cancer Treatment (Shen, et al., 2018), Diabetic (Sherimon & Krishnan, 2016) etc. Tiny research has been conducted on the subfertility of the female domain. So we plan to develop a Decision Support.

#### Evaluation results

It is obvious that not all the pitfalls are equally important; their impact in the ontology will depend on multiple factors. For this reason, each pitfall has an importance level attached indicating how important it is. We have identified three levels:

- **Critical** ⓘ : It is crucial to correct the pitfall. Otherwise, it could affect the ontology consistency, reasoning, applicability, etc.
- **Important** ⓘ : Though not critical for ontology function, it is important to correct this type of pitfall.
- **Minor** ⓘ : It is not really a problem, but by correcting it we will make the ontology nicer.

[Expand All] | [Collapse All]

Results for P04: Creating unconnected ontology elements.	1 case   Minor ⓘ
Results for P07: Merging different concepts in the same class.	4 cases   Minor ⓘ
Results for P08: Missing annotations.	126 cases   Minor ⓘ
Results for P10: Missing disjointness.	ontology*   Important ⓘ
Results for P11: Missing domain or range in properties.	1 case   Important ⓘ
Results for P13: Inverse relationships not explicitly declared.	1 case   Minor ⓘ
Results for P21: Using a miscellaneous class.	1 case   Minor ⓘ
Results for P22: Using different naming conventions in the ontology.	ontology*   Minor ⓘ
Results for P41: No license declared.	ontology*   Important ⓘ

## Conclusion

In the subfertility area, Female subfertility is a vast area than male subfertility of the gynaecological part in the medical area. So Normally, Doctors and medical students have some confusions about decision making in the area. This Ontology design helps to how to find the causes and to find treatment methods for every cause.

Subfertility of female Domain ontology designing is not a simple task. Designing the ontology in the subfertility of the female domain is not an easy task because this is a vast area than male subfertility. The difficulties in the female subfertility domain and the need to gain vast domain knowledge made this task more tedious. This research female subfertility treatment method decision-making ontology, which represents female subfertility domain knowledge. It includes female subfertility treatment method concepts, their properties such as object property and data property, and their relationships. We confidently believe that our female subfertility ontology can help the gynaecological area, doctors and medical students, and other active researchers in this field to improve not only decision-making

and also the knowledge sharing and experiences.

We have two future work to expand this research work. Firstly we are planning to enhance our research on the subfertility of females. After that as second, Development of Decision Support System which helps to take decisions such as finding causes using medical history & diagnosis and finding treatment for female subfertility. More than that, Even though there are some works on a decision support system such as Cancer Treatment (Shen, et al., 2018), Diabetic (Sherimon & Krishnan, 2016) etc. Tiny research has been conducted on the subfertility of the female domain. So we plan to develop a Decision Support System for the subfertility of females.

## References

- Adamson, G. D., 2003. Subfertility : causes , treatment and outcome. pp. 169-185.
- Choraś, M., Kozik, R., Flizikowski, A. & HołuboChoraś, M. W., 2010. Ontology applied in decision support system for critical infrastructures protection. *Lecture Notes in Computer Science (including subseries Lecture Notes in Artificial Intelligence and Lecture Notes in Bioinformatics)*, pp. 671-680.
- Ferenc, R., 2016. Ontology Evaluation Approaches: A Case Study from Agriculture Domain. Volume 3, pp. 625-638.
- Gnoth, C. et al., 2005. Definition and prevalence of subfertility and infertility. *Human Reproduction*, pp. 1144-1147.
- Gruninger, M. & Fox, M., 1995. *Methodology for the Design and Evaluation of Ontologies*. s.l.:Workshop on Basic Ontological Issues in Knowledge Sharing, IJCAI-95, Montreal.
- Haghigh, D., Burstein, F., Zaslavsky, A. & Arbon, P., 2013. Development and evaluation of ontology for intelligent decision support in medical emergency management for mass gatherings. *Decision Support Systems*, pp. 1192-1204.
- Indika Walisadeera, A., Ginige, A. & Wikramanayake, G. N., 2014. Conceptualizing crop life cycle events to create a user centered

ontology for farmers. *Lecture Notes in Computer Science (including subseries Lecture Notes in Artificial Intelligence and Lecture Notes in Bioinformatics)*, Volume PART 5, pp. 791-806.

Joffe, M. & Li, Z., 1994. Male and female factors in fertility. *American Journal of Epidemiology*, pp. 921-929.

Larsen, U., 2005. Research on infertility: Which definition should we use?. *Fertility and Sterility*, pp. 846-852.

Shen, Y. et al., 2018. Constructing ontology-based cancer treatment decision support system with case-based reasoning. *Lecture Notes in Computer Science (including subseries Lecture Notes in Artificial Intelligence and Lecture Notes in Bioinformatics)*, pp. 278-288.

Sherimon, P. C. & Krishnan, R., 2016. OntoDiabetic: An Ontology-Based Clinical Decision Support System for Diabetic Patients. *Arabian Journal for Science and Engineering*, pp. 1145-1160.

Stanford, J. B., White, G. L. & Hatasaka, H., 2002. Timing Intercourse to Achieve Pregnancy. *Obstetrics & Gynecology*, pp. 1333-1341.

Vander Borgh, M. & Wyns, C., 2018. Fertility and infertility: Definition and epidemiology. *Clinical Biochemistry*, pp. 2-10.

Vasanthapriyan, S. & Banujan, K., 2019. An ontological approach for dental extraction decision making and knowledge dissemination. *Journal of Computer Science*, pp. 832-843.

Vasanthapriyan, S. et al., 2017. An ontology-based knowledge management system for software testing. *Proceedings of the International Conference on Software Engineering and Knowledge Engineering, SEKE*, pp. 230-235.

Walisadeera, A. I., Wikramanayake, G. N. & Ginige, A., 2013.

An ontological approach to meet information needs of farmers in Sri Lanka. *Lecture Notes in Computer Science (including subseries Lecture Notes in Artificial Intelligence and Lecture Notes in Bioinformatics)*, pp. 228-240.

## Acknowledgement

We pay our heartfelt gratitude to the Doctor Shinthuja Ranjit of Nation Hospital of Sri

Lanka. Further, we acknowledge medical students Miss. Karthiga Rajasingam, Mr. Sithambarabanan Kathirgamanathan, Mr. Thanistan Raj, Mr. Ajith Jerom Mathuranayagam and the other domain experts who have directly and indirectly tangled in order to finish the research work effectively and successfully.

## Author Biographies



Thenuka Yogarajah is an undergraduate student following Computing and Information Systems at the Sabaragamuwa University of Sri Lanka.

She is interested in medical field researches which are associated with Information Technology Field and Knowledge Management.



Dr. Shanmuganathan Vasanthapriyan who is a Senior Lecturer and Department Head of Computing and Information Systems in the Sabaragamuwa

University of Sri Lanka. His research interests include knowledge management, Software Engineering, Software Testing, Social Media, Ontologies, and Knowledge Management, etc.



Kuhaneswaran Banujan received his Bachelor of Science degree in 2019 with the Second Class Upper Division from Sabaragamuwa University of Sri Lanka. He is currently attached to the Department of Computing and Information Systems as a Lecturer in Computer Science. His research interests include Data Mining, Knowledge Management, Ontology Modeling, and Business Process Simulation.

## A Mix Model approach for identifying occupational stress among the Information Technology employees: A Case Study

M.M.K.R.I.E.Senavirathne#, and R. M. Kapila Tharanga Rathnayaka

*Department of Computing & Information Systems, Faculty of Applied Sciences, Sabaragamuwa University of Sri Lanka, P. O. Box 02, Belihuloya.*

#iroshinisenavirathne@gmail.com

**Abstract** The aspiration of involving the growth, maintenance, and the use of computer systems, software, and networks for the processing and diffusion of data can be identified as information technology. Being a much useful field of knowledge in storing, retrieving, manipulating, and communicating information, IT has grown as a commercial industry today, where millions are actively engaged as a labor force in companies globally. Employee training and adoption in the industry is a time-consuming task, which affects the employee turnover of the industry. When the turnover rate goes high, it affects the company profit. Here we are focusing on mapping reasons that are affecting turnover and suggest a solution. This paper reports the results of Systematic Literature Review (SLR) related to software and systems. This SLR is a preliminary one that only analyzed articles in ACM digital library and IEEE computer society digital library that shows interesting trends about employee turnover research conducted the SLR published between 1999 to 2019, which formulated and applied specific inclusion and exclusion criteria to determine the most relevant studies for the research goal. Planning, conducting, and reporting three main phases used in this study as guidelines were given by Kitchenham and Charters. Research questions were created to find out answers about the employee turnover rate. Research articles were analyzed the filtered according to the year, country, and type of research such as journals, conference papers,

or paradigm papers. This literature review will be useful to design the questionnaire. The factors that should consider were gained from the literature review.

**Keywords** Occupational stress, IT industry, Employee turnover, systematic literature review, IT personnel

### Introduction

After reaching the independence, the economy of Sri Lanka was opened to free trade, and agriculture is mainly influenced it. In 1977 the new liberal economic policies were adopted. After that, the new industries have been created and the export structure has become diversified. The IT industry is one of such emerging industries. The emerging economy, in which services, communications, and information technologies play a significant role has created new avenues for skilled workers. Liberalization has also been heading towards globalization (Agarwal and Mehta, 2014a).

The Computer Society of Sri Lanka was started in 1976 for promoting information and communication technology and professionalism among those engaged in the field. In the 1980s the Software Industry has started in Sri Lanka. After the mid-1990s, the IT industry has started to setting-up operations for the international market and then the industry has been expanded (Jinadasa and Wickramasinghe, 2005). Since then a lot of people are interested in this field and so many of them tend to work in this



industry. It is rapidly developed over the past two decades. It has happened with globalization and economic liberalization. The Information Technology Society of Sri Lanka has started in 2019 to enhance the IT knowledge of the Sri Lankan people. IT companies build knowledge workers by absorbing qualified employees. This is considering the reasons for the increasing employee turnover rate in the IT industry. The World web dictionary defines employee turnover as the ratio of the number of workers replaced in a given time period to the average number of workers.

A lot of government universities and private universities are bring-forth new IT qualified employees every year. Most of them work in Software Companies and others are working at IT-related professions. After graduation, they start their careers. They should continue it until the end of their career life. But today there is employee turnover in the IT industry as same as the foreign countries. A lot of them are changing their career paths in the middle of life. They involve different kinds of jobs after resigned from the company. The major challenge for present-day organizations is employee turnover. It is an important threat and formidable challenge for managers. Employees leave their jobs for a variety of reasons. According to the Branham's study (1995), he mentions that this turnover happens because of the older employees at the top will incur high expenses, but new employees bring fresh ideas, approaches, abilities, and they have new attitudes and keep the organization from becoming stagnant (Chauhan and Patel, 2013). There are a lot of factors that cause employee turnover. Most IT organizations conduct Performance Appraisals (PA) to assess and compensate employee performance (Sethunga and Perera, 2018)

According to the Information & Communications Technology (ICT) Manpower survey (1999), 43.6% of ICT

professionals are working on software development companies. Further, the study says that the annual growth rate of software development manpower is 14.7%. Due to the recent increase in demand for IT Knowledge workers, demand for qualified computer professionals, especially university graduates, is high and retention is a problem. Leading companies in the field snap up fresh computer science graduates. This situation has led the IT industry to a competitive edge (Jinadasa and Wickramasinghe, 2005). There are advantages as well as disadvantages for employee turnover. On one side, low-quality employees can replace them. According to that the creativity, flexibility, and adaptability of the company can be developed (Zhang, 2016). Tett and Mayer have done research related to this topic. They have work considering the relationships among job satisfaction, turnover intention, and organizational commitment. It has been stated that all of these things are performed independently in employee turnover (Meyer and Tett, 1993).

### **Methodology**

Perhaps the easiest way to comply with the conference paper formatting requirements is to use this document as a template and simply type your text into it. When using this as a template, you do not need to worry about page layout, fonts, etc. The main body of the paper should be organized into sections, as Introduction, Methodology, and Experimental design, Results, Discussion and Conclusion, Acknowledgement, and References. The abstract (already accepted) should be included at the beginning. Papers, excluding the abstract portion, shall not exceed **six (06)** pages in length.

#### **A. Systematic Literature Review**

The review carried out in our research consists of three main phases: Planning: participating in online databases such as IEEE Explorer, Springer, and ACM Digital

Library, etc., defining the study questions, defining the search terms to be used to obtain the studies, and finally the mapping procedure; Conducting: scan the selected electronic repositories with relevant search terms and pick the studies concerned, reviewing the selected studies and finalizing the mapping study; and Reporting: a final stage that aims to document all the necessary results prioritizing the retrieved studies and circulating them, and answering the relevant research questions which were defined in the planning phase. The above mapping procedure was based on the guidelines provided by Kitchenham and Charters (De Souza, Falbo, and Vijaykumar, 2015).

**Planning:** Initially, the search terms to be provided to the electronic databases were identified to retrieve any research papers related to our interest in the research. The search strings have to be specifically described with the awareness of the keywords identified in the research concerned. We are doing pre-review activities, and the objective is to develop a review protocol to identify the research problem, inclusion and exclusion criteria, source studies, search string, and mapping procedures.

**Conducting:** In this phase, we search and select studies, in order to extract and synthesizes data from them. The identified terms of search have been placed in the electronic databases and the results obtained have been analyzed.

**Reporting:** This is the final phase. This aims at writing up the results and circulating them to potentially interested parties. The findings of the systematic mapping studies are used to answer the research questions in this phase. All the summarized and filtered research papers were fed into a tabular form with the contents. Title, Abstract, Keywords, and Research Objectives Defined, Research Questions, Methodology Used, and Summary of the Results, Threats to Validity / Barriers

and Future Perspectives. They were all produced into three structured documents: a systematic literature review (SLR), a research summary, and a literature review. All the received research papers from various databases were entered into the SLR document. Finally, a detailed overview of the mapping research was presented in the literature review paper.

### B. Research Questions

The basic center of a mapping analysis is research questions. This table review aims at addressing the following Research Questions (RQs). It helps to identify the research gaps in the existing literature:

Table -1 Research Questions

No	Research Question
RQ1	What types of research have been done? There are researches related to this topic and all of them are done in foreign countries. It means they also have the same problem. They have found some reasons for this problem such as stress, unsatisfied job, etc.
RQ2	Does this research propose a new idea or enhance existing ideas? The related researches have been done earlier in the other countries and they are also not given a solution to the problem. But this is new to Sri Lanka. There are very few researches conducted and not given any solution to this real-world problem.
RQ3	What kinds of artifacts have covered from this research? We will analyze two aspects of artifacts. They are academic and occupational reasons. There are academic problems that cause this problem. It can be course content, having less practical content, etc. The occupational reasons may be unsatisfying staff, stress, leisure time problems, etc. Therefore we should have to determine the representation method of artifacts from its content. It can categorize the contents of the artifacts and analyze the data.
RQ4	Does research show whether research will contribute to achieving its intended purposes? This is related to the evaluation of research. If the purpose of this research is

	improving the accuracy of the impact analysis, making a comparative experiment with or without the research outcome. It shows the contribution of the research.
RQ5	What are the methodologies used? According to studies researches, most of them have been done by using the mail survey and interviews. And used the data analysis tools for analyze the collected data.

### C. Study Selection

To retrieve articles as many as possible, using the word “Employee Turnover” for the search page libraries. The authors then examined the abstract manually to exclude articles in step with the factors. The selection process for the related studies concerned the following essential factors: Definition of Search String, Sources of Searching, and Definition of inclusion and exclusion criteria, Data Storage.

#### a) Terms and search strings

The search string considers into two areas. It was applied in three metadata fields: title, abstract, and keywords. The search string went through syntactic adaptations according to the particularities of each source

This paper presents a second study which is based on analyzing primary studies. At the beginning of this study, I have studied a lot of primarily related work under this topic. They all have done within a mail survey and interviews. Survey data were collected by using a Software Company and the selected number of workers to collect data. The search string has been applied in the following electronic databases: IEEE Xplore, ACM Digital Library, Springer Link, Science Direct, Emerald Insight, and Research Gate.

*Table 2 Search terms of the tertiary study on text data mining*

Areas	Search terms
Text data mining	“text mining”, “data mining”,
Employee Turnover Or IT Industry	“Employee Turnover”, “IT industry”
Review	“Systematic Literature Review”, “Systematic Review”, “systematic mapping”, “mapping study”, “systematic literature mapping”
Search string	(“text mining” OR “data mining”) AND (“Employee Turnover” OR “IT industry”)

*Table 3 Search terms of the tertiary study on Occupational Stress or Employee Turnover*

Areas	Search terms
Occupational Stress, or Employee Turnover algorithms	“Occupational Stress”, “Employee Turnover”
Text data mining	“text mining”, “data mining”
Search string	(“Occupational Stress” OR “Employee Turnover”) AND (“text mining” OR “data mining”)

*Table 4 Search terms of the tertiary study on IT Industry in data mining*

Areas	Search terms
IT Industry	“IT Sector”, “IT Industry”
Text data mining	“text mining”, “data mining”
Search string	(“IT Sector” OR “IT Industry”) AND (“text mining” OR “data mining”)

Research can be performed in the following seven electronic databases. Below electronic databases are used to retrieve the articles.

- IEEE Xplore  
(<https://ieeexplore.ieee.org/Xplore/home.jsp>)

- ACM Digital (<https://dl.acm.org/>)
- Springer Link (<https://link.springer.com/>)
- ScienceDirect  
(<https://www.sciencedirect.com/>)
- Emerald  
(<https://www.emerald.com/insight/content/doi/10.1108/09593841011087798/full/html>)
- Researchgate.net  
(<https://www.researchgate.net/>)

**Inclusion and Exclusion criteria**

I have used the following inclusion and exclusion criteria for SLR

1. The articles that need to be review were downloaded and shared by authors.
2. Articles in ACM digital library and IEEE computer society digital library were included.
3. Articles published in June 2006 to September 1999 were included, and other articles were excluded. Note that this research was started at the end of September 2019.
4. Employee turnover related to software and software-intensive systems was included, and others were excluded.
5. Articles in magazines such as CACM or IEEE computer were excluded.
6. If the same article contains in both libraries, one of them was excluded.

**c) Data Storage**

All searching phase were cataloged and stored appropriately. Data extraction was developed and gather all relevant data from referred studies. As an example, Search terms, Title, Keywords, Abstract, Outcomes, Future works, URL, and other data were collected and input into an excel sheet.

**d) Data extraction and Synthesis**

During this study, publications from 1993 to 2019 were assessed. The below steps are followed for extracting and synthesize them. Then, the selection process parameters are continued on the chosen Publications identifying and extracting the research most linked.

Articles to be reviewed are downloaded and shared by authors.

- An author prepares a form for analyzing each article.
- For each article, two authors fill the form respectively by reading the contents of the article.
- Another author examines two filled forms for each article. If there are some inconsistencies in these forms, the author examines the contents of the article and fixes the inconsistencies.

All the results are arranged and sorted for answering the RQ's.

*Table 5 Finalize the research articles*

Source	IEEE Explore	Research Gate	Springer Link	Science Direct	Emerald Insight	ACM Digital Library	Other	Total
Number of Articles	8	9	1	6	3	15	2	44

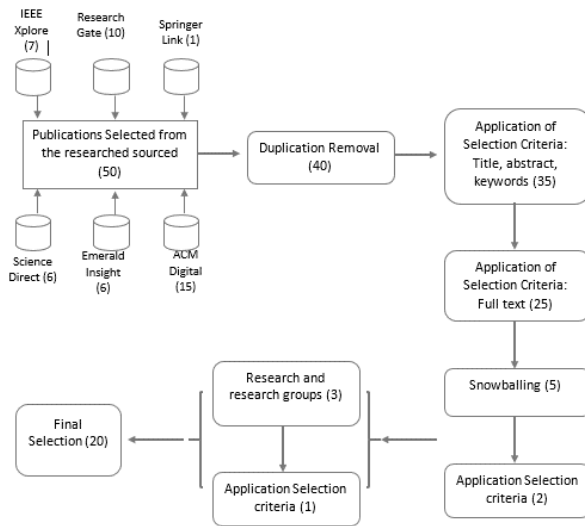

the selected studies cite other relevant studies, retrieve those studies, and continue this process until no more relevant studies are found. It is a process that checks if the selected studies cite other relevant studies, retrieve those studies, and continue this process until no more relevant studies are found.

When conducting this process, publications from 1999 to 2019 were considered. As a result of it, there were 50 research articles were selected from the electronic digital libraries (. Then after removing the duplications it filtered into 40 articles.

Figure 2-Data Extraction and Synthesize process

Table 6 Results of the selection stages

Stage	Criteria	Analyzed Content	Initial no of studies	Final no of studies
1st	IC1, EC1, EC2	Title, Abstract, Keywords	50	40
2nd	IC1, EC3, EC5	Title, Abstract, Keywords	40	35
3rd	IC1, Snowballing, EC4	Full text, Title, Abstract, Keywords	35	25
4th	Research group, IC1, EC4	Full text	5 (added by snowballing)	2 (added by snowballing)
5th	IC1, EC1, EC3, EC4	Full text	3 (added by research group) 1 (added by snowballing)	1 (added by research group) 1 (added snowballing)
Final			50(source)+ 5(snowballing)+3(research group) =58	25(source)+ 3(snowballing)+2(research Group) = 20

The data extraction criteria are doing as the above diagram. The snowballing means the primary study references, as well as by directly searching publications from researchers and research groups of the studies previously selected. And it checks if

Table 7 References of selected studies

ID	Reference
#1	V. S. Chauhan and D. Patel, "Employee turnover: A factorial study of IT industry," J. Strateg. Hum. Resour. Manag., 2013.
#2	C. Mofulatsi, "IT PROFESSIONAL PREMATURE TURNOVER IN INFORMATION TECHNOLOGY TRANSFORMATION PROGRAMMES IN THE TELECOMMUNICATION INDUSTRY," no. November, pp. 1–86, 2015.
#3	V. K. G. Lim and T. S. H. Teo, "Occupational stress and IT personnel in Singapore: Factorial dimensions and differential effects," Int. J. Inf. Manage., 1999.
#4	R. N. Agarwal and A. Mehta, "Impact of Performance Appraisal and Working Environment on the Job Satisfaction and Attrition Problem in the Indian IT Industry," Paradigm, vol. 18, no. 1, pp. 73–85, 2014.
#5	J. Yuan, "Predicting Employee Turnover from Network Analysis," in Journal of Physics: Conference Series, 2019.
#6	D. S. Raharjo and S. Sulistiasih, "THE MODEL OF MANUFACTURING INDUSTRIES EMPLOYEE PERFORMANCE," Int. Rev. Manag. Mark., vol. 9, no. 5, pp. 82–86, Sep. 2019.
#7	M. Elçi, İ. Şener, S. Aksoy, and L. Alpkan, "The Impact of Ethical Leadership and Leadership Effectiveness on Employees' Turnover Intention: The Mediating Role of Work Related Stress," Procedia - Soc. Behav. Sci., vol. 58, pp. 289–297, 2012.
#8	L. Jinadasa and V. Wickramasinghe, "IT Industry Labour Turnover : The Reality," 10th Int. Conf. Sri Lanka Stud., no. December 2005, pp. 0–10, 2005.
#9	J. Quan and H. Cha, "IT certifications, outsourcing and information systems personnel turnover," Inf. Technol. People, vol. 23, no. 4, pp. 330–351, 2010.
#10	Q. Weng and J. C. McElroy, "Organizational career growth, affective occupational commitment and turnover intentions," J. Vocat. Behav., 2012.
#11	S. Sethunga and I. Perera, "Impact of performance rewards on employee turnover in Sri Lankan IT industry," in MERCon 2018 - 4th International Multidisciplinary Moratuwa Engineering Research Conference, 2018.
#12	A. Mohammad Esmaeeli Sikaroudi and A. EsmaeeliSikaroudi, "A data mining approach to employee turnover prediction (case study: Arak automotive parts manufacturing)," J. Ind. Syst. Eng., 2015.
#13	Y. Zhang, "A Review of Employee Turnover Influence Factor and Countermeasure," J. Hum. Resour. Sustain. Stud., vol. 04, no. 02, pp. 85–91, 2016.
#14	L. Firth, D. J. Mellor, K. A. Moore, and C. Loquet, "How can managers reduce employee intention to quit?," J. Manag. Psychol., 2004.
#15	M. Purohit, "A Study on-Employee Turnover in IT Sector with Special Emphasis on Wipro and Infosys," J. Bus. Manag., 2016.
#16	J. H. Westover, A. R. Westover, and L. A. Westover, "Enhancing long-term worker productivity and performance: The connection of key work domains to job satisfaction and organizational commitment," Int. J. Product. Perform. Manag., 2010.
#17	J. P. Meyer and R. P. Tett, "Job Satisfaction, Organizational Commitment, Turnover Intention, and Turnover: Path Analyses Based on Meta-analytical Findings," Pers. Psychol., 1993.
#18	J. B. Thatcher, Y. Liu, L. P. Stepina, J. M. Goodman, and D. C. Treadway, "IT Worker Turnover: An Empirical Examination of Intrinsic Motivation1," Data Base Adv. Inf. Syst., 2006.
#19	P. Ampomah and S. K. Cudjor, "The Effect of Employee Turnover on Organizations (Case Study of Electricity Company of Ghana, Cape Coast)," Asian J. Soc. Sci. Manag. Stud., 2015.

Table 8 Datamining Perspective

Year	Number of Researches	Country
1993	#1	Canada
1999	#1	Singapore
2004	#1	Australia
2005	#1	Sri Lanka
2006	#1	USA
2010	#2	USA, USA
2012	#2	Turkey, China
2013	#1	India
2014	#1	India
2015	#3	South Africa, Iran, Ghana
2016	#2	China, India
2018	#1	Sri Lanka
2019	#2	USA, Indonesia
Total	20	

### Results and Findings

Articles to be reviewed are summarized. And most articles are journals, conferences, workshops, or symposium papers. There are different kinds of researches have done for this Occupational stress and IT personnel. But in Sri Lanka, there are a few types of researches that have been done under this topic.

Most of the researches are proved the causes of this problem. The training, openness, and flexibility are considered while leaving the organization (Chauhan and Patel, 2013). Growth opportunities, financial rewards and benefits, job satisfaction, and study highlights (Mofulatsi, 2015). The stress arising from a lack of support (Lim and Teo, 1999). Competition, fluctuating demand for

the software services, project management challenges, nature of work requirements are cause for this problem (Agarwal and Mehta, 2014b). The healthy relationships, if people at the periphery receive less information and may feel less committed to the organization, and the lack of commitment may cause the employee to leave the company (Yuan, 2019a). Leadership style, organizational commitment, work motivation, employee performance is caused for employee turnover (Raharjo and Sulistiasih, 2019).

Ethical leadership and work-related stress affect employee turnover intention (Elçi et al., 2012). And also the employees who are having a low salary are tended to leave the company (AR, Mitra and Umesh, 2018). A better job, personal commitments, higher studies, leave the country, doesn't fit with their level of expectations are cause for employee turnover in the IT industry (Jinadasa and Wickramasinghe, 2005). And also turnover intention of IT professionals is significantly influenced by the variables at the individual, firm, and environmental levels (Quan and Cha, 2010).

### RQ1: Research Type

Used mapping is as following that used for categorizing:

Propose a solution: the research has come up with the solution for a problematic area without any top to bottom examination.

Validation research: examine the properties of the proposed clarification without any practical implementation. It could be an existing one somewhere.

Evaluation research: here it inspects the implementation of the technique in practice, and what are the outcomes of the implementation in terms of benefits and drawbacks.

RQ2: Does this research propose a new idea or enhance existing ideas?

This is still novel to Sri Lanka through the problem is common. This problem is taking a dominant place in the IT industry. It is affecting the development of the world and the novel inventions. If more people work in the industry, it will invent novel things combined with technology. This will cover up a broad area of the problem.

RQ3: What kinds of artifacts have covered from this research?

Most of them cover occupational artifacts. They have proved that the reasons for the problem such as flexibility, unsatisfying staff, stress, leisure time problem, flexibility, financial rewards, and benefits, etc. Most of the researches have been highlighted the common problems. Such as soft productivity factors, involuntary and voluntary resigning, etc

RQ5: Does research show whether research will contribute to achieving its intended purposes?

The articles specified the purpose. Here it analyzes how to confirm whether the purpose is achieved in each article. It shows the ratio of whether the authors of an article provide the means for confirming that the purpose is achieved. And also it is provided by more than 80% of articles. This result is reasonable because articles are rarely accepted today without any kind of evaluation. Then we focus on the types of evaluation. The types are very few. Although a rigorous case study is hard to be performed. The evaluation means is a little bit weak in more than 60% of articles.

RQ6: What are the methodologies used?

Data was collected from a self-designed questionnaire that was administered on the respondents working on the IT industry. The collected data were analyzed in two stages using the statistical package for social science (Chauhan and Patel, 2013).

A combination of mail surveys and interviews was used to collect data. The questionnaire was mailed to a selected sample of workers (Mofulatsi, 2015).

Data were collected via a combination of mail surveys and interviews. Survey data were collected from 257 IT personnel employed in an organization dealing with IT-related services and products (Lim and Teo, 1999).

Two data sets are included: dataset1 involves 104 employees from a market-listed Chinese company dataset2 regards 20 employees from one of the departments of a large multinational corporation in Chengdu. The following four indicators are selected: in-degree (Ki), out-degree (KO), degree (K), and k-shell (Ks). Logistic regression analysis is performed for each network indicator on employee turnover. Two networks are considered: the action network and friendship network (Yuan, 2019a).

The descriptive and explanatory survey with sample size is 450 employees, as the method analysis used the path analysis (Raharjo and Sulistiasih, 2019).

Most of them are used reliability analysis, demographic analysis, correlation analysis (AR, Mitra and Umesh, 2018), Logistic regression analysis (Yuan, 2019b) (Quan and Cha, 2010) as data analysis techniques (Sethunga and Perera, 2018).

The correlation technique uses to determine the degree of association between two variables or to determine how strongly two variables are related to each other. And also the questionnaire was structured to be very accurate and descriptive as possible.

## Conclusion

Datamining analyzing methods and techniques have been proposed and evaluated in the literature. When conducting this study I have gathered, classified, and analyzed the research articles. And also analyzed the techniques, considered the mail



survey questionnaires. Viewed the related articles and filtered the most suitable articles among them. Finally selected nearly 20 research articles that are most suitable and most related to this research topic. The research questions (RQ) are based on previous bias mention in the introduction. It helps to have an overall idea regarding the research.

These all of the researches are analyzed in this literature review and this helps to understand the overall domain about all of the researches which have been done under the employee turnover topic. And also gathered the factors that can affect the problem. There are several kinds of factors but they don't cover all types of factors. They are summarized in this systematic literature review. The knowledge will be applied to conduct this research in the future. Most of them are reveal that training, openness, flexibility, job satisfaction, competition, financial rewards, lack of support, project management challenges, nature of work requirements are caused for this stress and the employee turnover. Considering this the questionnaire can be designed in the research.

## References

- Agarwal, R. N. and Mehta, A. (2014) 'Impact of Performance Appraisal and Working Environment on the Job Satisfaction and Attrition Problem in the Indian IT Industry', *Paradigm*, 18(1), pp. 73–85. doi: 10.1177/0971890714540367.
- AR, R., Mitra, S. and Umesh, A. (2018) 'Data Mining: Employee Turnover in a Company', *Ijarcce*, 7(11), pp. 59–62. doi: 10.17148/ijarcce.2018.71112.
- Chauhan, V. S. and Patel, D. (2013) 'Employee turnover: A factorial study of IT industry', *Journal of Strategic Human Resource Management*.
- Elçi, M. et al. (2012) 'The Impact of Ethical Leadership and Leadership Effectiveness on Employees' Turnover Intention: The Mediating Role of Work Related Stress', *Procedia - Social and Behavioral Sciences*, 58, pp. 289–297. doi: 10.1016/j.sbspro.2012.09.1003.
- Jinadasa, L. and Wickramasinghe, V. (2005) 'IT Industry Labour Turnover: The Reality', 10th International Conference on Sri Lanka Studies, (December 2005), pp. 0–10.
- Lim, V. K. G. and Teo, T. S. H. (1999) 'Occupational stress and IT personnel in Singapore: Factorial dimensions and differential effects', *International Journal of Information Management*. doi: 10.1016/S0268-4012(99)00027-4.
- Meyer, J. P. and Tett, R. P. (1993) 'Job Satisfaction, Organizational Commitment, Turnover Intention, and Turnover: Path Analyses Based on Meta-analytical Findings', *Personnel Psychology*, 46, pp. 259–293.
- Mofulatsi, C. (2015) 'IT PROFESSIONAL PREMATURE TURNOVER IN INFORMATION TECHNOLOGY TRANSFORMATION PROGRAMMES IN THE TELECOMMUNICATION INDUSTRY', (November), pp. 1–86.
- Quan, J. and Cha, H. (2010) 'IT certifications, outsourcing and information systems personnel turnover', *Information Technology and People*, 23(4), pp. 330–351. doi: 10.1108/09593841011087798.
- Raharjo, D. S. and Sulistiasih, S. (2019) 'THE MODEL OF MANUFACTURING INDUSTRIES EMPLOYEE PERFORMANCE', *International Review of Management and Marketing*, 9(5), pp. 82–86. doi: 10.32479/irmm.8594.
- Sethunga, S. and Perera, I. (2018) 'Impact of performance rewards on employee turnover in Sri Lankan IT industry', in *MERCon 2018 - 4th International Multidisciplinary Moratuwa Engineering Research Conference*. doi: 10.1109/MERCon.2018.8421961.
- De Souza, É. F., Falbo, R. D. A. and Vijaykumar, N. L. (2015) 'Knowledge management initiatives in software testing: A mapping study', in *Information and Software Technology*. doi: 10.1016/j.infsof.2014.05.016.
- Yuan, J. (2019) 'Predicting Employee Turnover from Network Analysis', *Journal of Physics: Conference Series*, 1168(3). doi: 10.1088/1742-6596/1168/3/032030.

Zhang, Y. (2016) 'A Review of Employee Turnover Influence Factor and Countermeasure', Journal of Human Resource and Sustainability Studies, 04(02), pp. 85-91. doi: 10.4236/jhrss.2016.42010.

#### **Acknowledgement**

This research was supported by the Department of Computing & Information Systems, Faculty of Applied Sciences, Sabaragamuwa University of Sri Lanka.

#### **Author Biographies**



M.M.K.R.I.E. Senavirathne is an undergraduate student reading for her Bachelor of Science degree specialized in Computing and Information Systems under the Faculty of Applied Sciences, Sabaragamuwa University of Sri Lanka.



Dr. R. M. Kapila Tharanga Rathnayaka is presently working as a Senior Lecturer in Statistics, Faculty of Applied Sciences, Sabaragamuwa University of Sri Lanka. He is highly interested in doing research in the fields of Financial Mathematics, Time series Modelling and Data Mining approaches.

## Air Quality Predicting System for Colombo City using Machine Learning Approaches

MDCM Wijethunga#, WMKS Ilmini

*Faculty of Computing, General Sir John Kotelawala Defence University, Sri Lanka*

#chamithmayura1995@gmail.com

**Abstract** Air pollution is one of the biggest threats to the environment and human beings. Because of the meteorological and traffic factors, the burning of fossil fuels, industrial activities, power plant emissions acts as major effects for air pollution. Therefore, the governments of the developing countries like Sri Lanka are majorly focused on the effects of air pollution and they create the rules & regulations to minimize the level of air pollution. The main purpose of this study is to design a Machine Learning approach to predict air pollution status and levels in Colombo city by analyzing the previous dataset of PM<sub>2.5</sub> air pollutants. This paper presents, how previous researches predict the air quality level using different types of technologies and data collection methods used to analyze the air quality. And also, it demonstrates the design and implementation of an air quality predicting system, named as Air Quality Predicting System for Colombo City using Machine Learning Approaches. A simple Linear Regression-based supervised machine learning algorithm is using for the predicting process and it gives 8.578 average Root Mean Squared Error (RMSE) value with higher accuracy. This system will implement in both web and mobile platform and it will provide a better user experience. In Sri Lanka, there is no way to predict the air quality based on the above scenario. Most of the researchers have used PM<sub>2.5</sub> air pollutant concentration levels as the main feature of their approaches due to the higher relationship to the Air Quality Index value.

And also those researches are mostly based on supervised machine learning algorithms like Linear regression, FFNN, & SVM algorithms.

**Keywords** Machine Learning approach, PM<sub>2.5</sub> air pollutant, air quality, Root Mean Squared Error

### Introduction

Air pollution is one of the most highly affected environmental issues in any country. Definition of Air pollution is the contribution of one or many pollutant elements polluting the air in various quantities and periods which may affect human, and animal life cycles directly or indirectly.

Colombo, the capital city of the Western province as well as the commercial capital of Sri Lanka is one of the coastal cities with degenerate air quality and condition. Most of the studies have recorded, that air pollution levels in Colombo is increasing during the last few years with the increase of traffic index, development of industries both public and private sector, domestic and commercial activities inside the city. These types of air pollutant levels are highly effective for the weather and climate condition of the city. Therefore, the wind direction and water cycle will be changed due to the results of these air pollutant levels. Fine particulate matter (PM<sub>2.5</sub>) acts as a major role along with other Air pollutant elements such as NO<sub>2</sub> and SO<sub>2</sub>. Because it highly affects the humans' and animals' health when its level in the air is relatively high. PM<sub>2.5</sub> means tiny particles

in the air that reduce visibility and cause the air to appear hazy when levels are elevated (Wei, 2014.). According to WHO "More than 80% of people living in urban areas that monitor air pollution are exposed to air quality levels that exceed WHO limits" ("Air pollution levels rising in many of the world's poorest cities," n.d.).

In Sri Lanka, according to the statistics of the National Building Research Organization (NBRO) measured results in 2017 show that pollutant levels are comparatively high in major traffic areas than in surrounding areas in the Colombo city ("National Building Research Organization (NBRO), 2017"). And it further tells annual average pollutant levels have increased rather than the recommended WHO guideline values for NO<sub>2</sub> and SO<sub>2</sub> within the Colombo city. For measuring these air pollutant elements, NBRO selected 19 sampling locations around the Colombo city and they monthly collect average levels of NO<sub>2</sub> and SO<sub>2</sub> gases and they collect data about 24-hourly average levels of PM<sub>2.5</sub>.

According to the statistical results of NBRO, incrementally increased pollutant levels are recognized by the WHO. Therefore, the need for the Air quality Predicting System is to implement predictive air pollution levels in the future by analyzing the present results. By using these types of systems, authorities of the relevant fields can get decisions about future planning without any hesitation about the air pollution issues.

Therefore, this paper presents a way to predict air quality details from using previous air pollutant data and machine learning approaches. By implementing the "Air Quality Predicting System for Colombo city", users can able to understand the effectiveness of the air pollutants in Colombo city and authorities can able to adapt to the situation by introducing a different type of rules and regulations.

The rest of this paper is created as follows. Section 2 describes related works and existing systems regarding the field. Section 3 describes the structure and the processes of the proposed Air Quality Predicting System for Colombo city. Section 4 describes the conclusion of the paper and section 5 describes the future work of the ongoing system.

With the rapid development of the Machine Learning (ML) approaches, most of the manual systems are turned into the ML-based automated systems due to the accuracy of the ML approaches. Therefore, most of the manual air pollution systems are turned into the ML-based air pollution monitoring systems with containing prediction features. For the study about the usage of ML approaches in the above systems, this paper focused on nine ML algorithms namely Support Vector Machine, Support Vector Regression, Logistic Regression, Autoregression and Autoregressive nonlinear neural network, State of Art machine algorithm with the linear regression algorithm, Alternating Decision Tree, Random Forest algorithm, Feedforward Neural Network, Extreme Learning Machine for both data classification and prediction parts.

Dan Wei (Wei, 2014.) has implemented the Air pollution prediction system using the machine learning approaches in Beijing, China. The aim of the project was the prediction of air pollution levels in Beijing city with the ground data set. According to the paper, it performed machine learning techniques such as Support Vector Machine (SVM) and Neural Network, to predict the air pollutant level of the PM<sub>2.5</sub> based on a dataset containing Temperature, Wind Speed, Relative Humidity, Traffic index, the Air quality of previous day. The training data set has 322 observation points and the test data has 55 points. output data was categorized as one or zero. One refers to the high pollution

level and zero refers to the low pollution level. The total number labelled as zero is 103, while the remaining 274 points are labelled as 0. They measured these levels, based on the values of the  $PM_{2.5}$  and he simplified the  $PM_{2.5}$  level into a binary digit to classify the  $PM_{2.5}$  level into "High" ( $> 115 \mu g/m^3$ ) and "low" ( $\leq 115 \mu g/m^3$ ). The value is chosen based on the Air Quality Level standard in China, which set  $115 \mu g/m^3$  to be mild level pollution. To measure these levels, he used three supervised learning algorithms were used: logistic regression, Naïve Bayes Classification & Support Vector Machines (SVM). Among these algorithms, he selected SVM as the best classifier for this case based on the prediction results. And also, he mentioned, "the data set in that project is not large enough, Because of the Air quality is a long-term formed problem and it is better to use a large data covering a variety of years and locations".

Aditya C R and others (Vidya Vikas Institute of Engineering and Technology et al., 2018) have introduced the Air Pollution monitoring system with both detection and prediction functions to predict  $PM_{2.5}$  level and detect air quality based on a dataset consisting of daily atmospheric conditions in a specific city. As they said in the paper, "there are applications that display the real-time  $PM_{2.5}$  levels, while some show the forecast of a particular day. However,  $PM_{2.5}$  levels for dates after a week is not forecasted". Therefore, they proposed this system to do both two tasks (detection and prediction) based on the  $PM_{2.5}$  level by using the dataset that contained Temperature, Wind Speed, Dewpoint, Air pressure,  $PM_{2.5}$  Concentration( $\mu g/m^3$ ), and previous results. According to the paper they have selected two machine learning algorithms to detect and predict the Air pollution level; (i) Logistic Regression Algorithm used to detect the levels of  $PM_{2.5}$  based on the data values and, (ii) Autoregression is used to predict future

values of  $PM_{2.5}$  based on the previous  $PM_{2.5}$  readings. As they mentioned in the paper, the reason behind selecting these algorithms, results depict Logistic Regression best for that system with the mean accuracy and standard deviation accuracy to be 0.998859 and 0.000612 respectively. Finally, they think this system will provide common people as well as those in the meteorological department to detect and predict pollution levels and take the necessary action following that.

C.S. Elvitigala and B.H. Sudantha (Elvitigala and Sudantha, 2017.) have developed another system for monitoring Air pollution by using datasets they collected using IoT devices with a sensory array. This system is proposed to use in the city of Colombo, Sri Lanka. They aim is to give a complete solution for monitoring and analyzing air pollution. Because of this, still, this process is done by using the manual procedure and it cannot forecast the air pollution level of the future with evidence. First, they have categorized air pollutants into three sections; (i) Primary pollutants, (ii) Secondary pollutants, and (iii) Minor Air pollutants. After that, they analyzed those pollutants and selected Carbon monoxide (CO) as the air pollutant for measuring the level of air pollution in Colombo city. The proposed system includes four main parts; (i) The microcontroller with module connection slots, (ii) The wireless communication device through the WiFi module. (iii) The data classifying and storing server. (iv) Machine learning and graphing software. They collect data about CO concentration by using multiple IoT devices which are in the different locations around the Colombo. They have done the prediction part of the system by using a linear regression algorithm. Finally, these predicted data are visualized by using the graph that was created from the TensorFlow (TensorFlow Core | Machine Learning for

Beginners and Experts, 2020) machine learning packages. As they said in the paper, “The system is a complete low-cost solution to monitor the environment pollution as the sensor devices are low cost to buy and easy to set up in a given environment”. And also, they think, this system will help the government to develop the Colombo city with environmentally friendly in the future.

Mahmoud Reza Delavar and others (Delavar et al., 2019) have proposed the Air pollution prediction system for Tehran, Capital of Iran intending to predict the density of air pollutants (Carbon monoxide (CO) and Nitric oxide (NO<sub>x</sub>) in industrial locations around the city. And also, they used PM<sub>2.5</sub> and PM<sub>10</sub> air pollutant elements used as an input for the machine learning algorithms. According to the paper, they used two types of datasets for predictions; first dataset, the refined meteorological data, and unrefined pollutant data, and in the second dataset, refined meteorological data and pollutant data with the attributes, air pressure, temperature, humidity, rainfall and wind speed. Datasets have been created using satellite imagery and ground sensors. They have been used artificial neural network (ANN), the nonlinear autoregressive exogenous Neural Network, geographically weighted regression (GWR), and support vector regression (SVR) were used to prediction process. By using the results, for each of these algorithms they selected autoregressive nonlinear neural network as a prediction model for the above system. Because it is the most reliable and accurate algorithm for the project. They mentioned in the paper errors can be occurred when the modeling and analysis processes. Therefore, they used the Savitzky–Golay filter to reduce the noises and errors.

Gaurav Pandey (Pandey et al., 2013) has implemented another air pollution predicting approach which is used in Hangzhou, China. The study aims to analyze

the collected data from the observations of weather and traffic variables and using machine learning techniques for the prediction of submicron-sized ambient air pollutants like PM<sub>1.0</sub> and Ultra Fine Particles (UFP). According to the journal paper, “this paper is the first study on predicting levels of submicron particles based on weather and traffic factors using a systematic classification approach”. They processed these collected data by using twenty-five classification techniques to predict discrete levels of UFP and PM<sub>1.0</sub> concentrations. They used a wide variety of classifiers, such as Neural Network, Bayesian Network, SVM, and Decision Trees (and their parameters). According to the results of the project, Tree-based classifiers such as Alternating Decision Tree (ADTree) and Random Forests (RFs) produced the most accurate predictions for PM<sub>1.0</sub> and UFP air pollutants.

Ilias Bougoudis and others (Bougoudis et al., 2016) have introduced a slightly different approach called, “Easy Hybrid Forecasting (EHF)”. It can predict the level of air pollutants without using real-time measurements from sensors or any other devices. The paper aims to develop an innovative, cost-effective, accurate air pollution predicting system with an extreme air pollutant value. Data for datasets were collected from four measurement stations. Datasets contained hourly measurements of the following air pollutants: CO, NO, NO<sub>2</sub>, O<sub>3</sub>, SO<sub>2</sub> for the period of 2000–2012. They used Fuzzy C means, Neural Gas Artificial Neural Networks (NGANN), Unsupervised Self Organizing Maps (UNSOM), and Semi-Supervised Self Organizing Maps (SEMSOM) for the clustering the data. After that they tried several algorithms for regression analysis of the system such as Random Forests, k-Nearest Neighbor (k-NN), Feed Forward ANN(FFANN), Radial Basis Function ANN and Support Vector Machines like e-SVR) and Linear Regression. By

considering the results of each of these regression algorithms, the FFANN algorithm gave the most reliable results for the input variables. As they said in the paper, this system can provide highly accurate predictive details of air pollution levels in a specific city by using the mobile phone without using any expensive device or software.

Ayaskanta Mishra (Mishra, 2018.) has introduced another air pollution forecasting system with using IoT device to discover the best prediction and forecasting model for analyzing the effect from the air pollutants like O<sub>3</sub>, NO<sub>2</sub>, SO<sub>2</sub>, and CO. This proposed IoT device used to collect real-time data, to expand the Machine Learning model. And also, they used authorized open-source datasets from the US government to train the model for giving better prediction results. They have used three machine learning algorithms, such as Linear Regression, Random Forest, and XGBoost for predictive modeling and Autoregressive integrated moving normal (ARIMA) model for time-series forecasting to find out the best algorithm for calculating Air Quality Index (AQI) for the above air pollutants. According to the results of the performance analysis, the Random Forest algorithm gave the most reliable results.

Jan Kleine Deters and others (Kleine Deters et al., 2017) introduced a new model to analyze the air quality of the Quito, the capital of. According to the paper, they planned to predict the concentrations of PM<sub>2.5</sub> by using machine learning approaches based on six years of meteorological and pollution data. They collected data from two air quality monitoring sites located in Quito (Cotocollao and Belisario). And also, they collected data about wind speed and direction in 6 years to create the classification model with more reliability. They have used Supervised learning algorithms (Boosted Trees (BTs) and Linear

Support Vector Machines (L-SVM)) to create models for the classification task. All computational and visualization parts are done by using Matlab. BT, L-SVM, and Neural Networks (NN) are used to process regression analyses for both sites. After that, they have used the Convolutional Generalization Model (CGM) for optimizing the regression. Results are shown, CGM performs it's best in the regression analyses by comparing it with other algorithms in both sites.

Bing-Chun Liu and others (Liu et al., 2017) have discussed another approach to check out the urban air quality of China. It is aimed to present a new model for the Air Quality Index (AQI) forecasting using collaborative multiple city air quality data as input. They selected Beijing, Tianjin, and Shijiazhuang in China for their research area. They have collected raw data such as daily air pollutant concentration data from the China Environmental Monitoring Center and daily weather conditions and meteorological data from the China Meteorological Administration. These collected data categorized into 12 characteristic variables including the six air pollutants concentration namely "PM<sub>2.5</sub>", "PM<sub>10</sub>", "SO<sub>2</sub>", "CO", "NO<sub>2</sub>" and "O<sub>3</sub>"; five variable weather conditions namely "minimum temperature", "maximum temperature", "weather", "wind direction" and "wind power"; and the last day's observed AQI values. They have used one single machine learning algorithm called Support Vector Regression (SVR) for predicting AQI and regression analyses. According to the results, SVR is less prone to overfitting than Artificial Neural Networks (ANNs) due to the presence of regularization parameters.

Jiangshe Zhang and Weifu Ding (Zhang and Ding, 2017) have proposed another approach to predict the Air pollutant concentration level in Hong Kong. They have used the Extreme Learning Machine (ELM)

*Table 1 Classification of Researches based on Technology/Algorithm*

No.	Research paper	Used Technologies/ Algorithms	Comments
1	(Wei, 2014.)	SVM	lowest test error, 9.09%, and the 0.722 precision
2	(Vidya Vikas Institute of Engineering and Technology et al., 2018)	Logistic Regression Algorithm (detection process) & Autoregression Algorithm (prediction process).	mean accuracy-0.998859, standard deviation-0.000612 and Mean Squared Error (MSE) to be 27.00
3	(Elvitigala and Sudantha, 2017.)	Linear regression algorithm	Only uses the Linear regression algorithm, because they use linear type data from IoT devices & sensor arrays.
4	(Delavar et al., 2019)	Autoregressive nonlinear neural network (NARX)	NARX- 40% increase in R2 and a 94% decrease in RMSE occurs.
5	(Pandey et al., 2013)	ADTree and Random Forests	Accuracy rate-98.6%
6	(Bougoudis et al., 2016)	FFANN for regression	comparing the Coefficient of Determination (R <sup>2</sup> ) values the is much high effort in FFANN
7	(Mishra, 2018.)	Random Forest algorithm	Avg. MAE: 0.0083 Avg.RMSE: 0.0316
8	(Kleine Deters et al., 2017)	BTs, L-SVM for classification & CGM for regression	CGM performs best in the regression analyses
9	(Liu et al., 2017)	SVR	MAPE and RMSE value less than 12
10	(Zhang and Ding, 2017)	ELM	RMSE-14.3, R <sup>2</sup> 0.71

algorithm for predicting the Air pollutant levels by analyzing data from eight quality parameters in two monitoring stations (Sham Shui Po and Tap Mun) in Hong Kong for six years period. As well as they have tested other supervised algorithms (Combined Machine Learning Algorithm, PCA-RBF, Neurocomputing, and Feedforward Neural Network Based on Back Propagation (FFANN-BP)) by training

datasets, but due to the drawbacks of each of these algorithms ELM performs well in training datasets both quantitatively and qualitatively with minimum root mean square error values.

Observing each of the above-mentioned research studies, most of them give a higher successful accuracy rate for their systems by using ML approaches. Table 1.0 shows the summarized classification of researches based on technology.

According to Table 1.0, most of the researchers are interested in using the SVM/SVR algorithm, Regression analysis, and Random Forest algorithm for their predictions due to the accurate results.

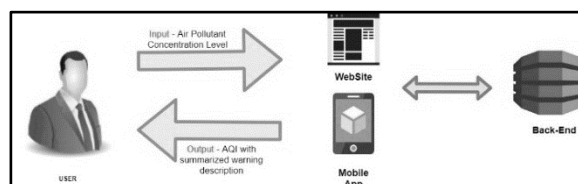

*Figure 1. overall workflow diagram*

### Anatomy of Air Quality Predicting System for Colombo City

This section discusses the design and implantation of the Air Quality Predicting System up to now. Because at this moment the system is in its development stage. The proposed system aims to predict the future Air Quality Index (AQI)/Level and provide the summarized warning description by considering the present & past data of the air pollutants. The system can predict the quality of the air by getting PM<sub>2.5</sub> air pollutant concentration levels as input. After providing those data through web or mobile interface to the system, the back-end of the system analyzes inputs and provides summarized air quality warning description with Air Quality Index (AQI) value to the user as an output. Figure 1 shows the overall workflow diagram of the system to understand the surface structure of the system.



The inside operations and technologies which are used to develop the system can be explained by identifying 5 major development phases namely Data collection and analyzing phase, Back-end development phase, Front-end development phase, Back-end & Front-end connection establishment phase, and User notification method development phase. The integration of these development phases can demonstrate the overall structure of the system and its functionality. The following sections give a brief description of each development phase.

#### A. Data Collection and Analyzing Phase

First, PM<sub>2.5</sub> and AQI values have been collected from the US Embassy of Sri Lanka and the National Building Research Organization. PM<sub>2.5</sub> dataset contains 20789 of raw data without any null values. And those collected data have to do correlation analysis to check the relationship between air pollutant concentration data with AQI value. So that provides a basic explanation about how well those data relate to another. At this moment, only did the correlation analysis for the PM<sub>2.5</sub> dataset with AQI value and it gives a higher value for the relationship. Figure 2 shows the result of that analysis study.

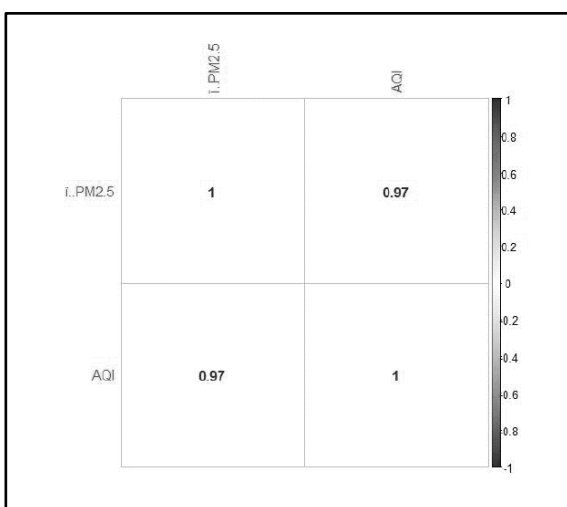

Figure 2. correlation analysis for PM<sub>2.5</sub> dataset and AQI value

#### B. Back-end development phase

In the back-end development stage, Simple Linear Regression-based supervised machine learning algorithm is using for the predicting process combining with sklearn (Getting Started — scikit-learn 0.23.1 documentation, 2020) and Pandas (Getting started — pandas 1.0.5 documentation, 2020) libraries. It predicts AQI value based on the PM<sub>2.5</sub> concentration value. Firstly, train the model with preprocessed data and test the model using those data. According to the study of related systems, the Simple Linear Regression algorithm has provided the highest accurate prediction results for those types of input data. Figure 3 shows the high-level architecture of the back-end part of the system.

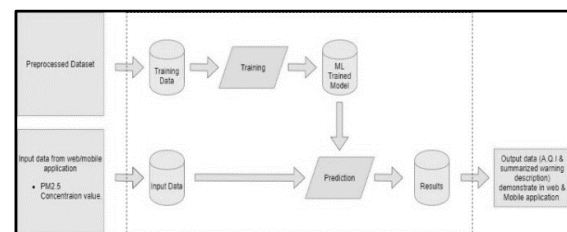

Figure 3. high-level architecture of the back-end part of the system

In the Simple Linear Regression algorithm, it used Mean Absolute Error (MAE), Mean Squared Error (MSE), and Root Mean Squared Error (RMSE) as a performance measurement of the trained algorithm to identify the accuracy of the algorithm. Table 2 represents those results for the given dataset.

Table 2. Performance measurements

performance measurement	Result
MAE	4.231920905485698
MSE	73.5694107009268
RMSE	8.577261258754266

According to the above performance measurements it produces more acceptable predicted values for given input values rather than other types of models. To prove that statement, It used,20% of data from the dataset for test the trained algorithm, and those results are shown in Figure 4.

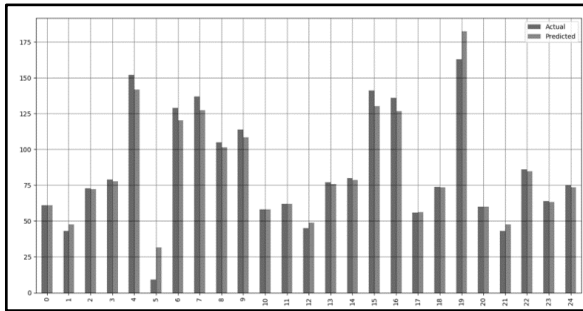

Figure 4. comparison of Actual and Predicted values of the first 25 data attributes

### C. Front-end development phase

The front-end development stage mainly uses an Angular framework for developing the web interface of the system using a firebase realtime database (Firebase, 2020) for implementing the user authentication process. So the system provides a role-based access control process to control access of admin and on the website. The website contains four main webpages namely “Home”, “Inputset”, “Dashboard”, “About US”. According to the role-based access control process, Admin can only access the “Inputs” webpage to the input Air pollutant concentration values. “Dashboard” page shows the AQI value and the summarized warning description to the users to understand the air quality of the present time.

The Android mobile application of the system has been developed by using the Flutter framework with the use of the Webview concept (The Power of WebViews in Flutter, 2020). Webview concept provides web applications to run inside the android application. Figure 5 shows the implementation of the dashboard page of the Android mobile application.

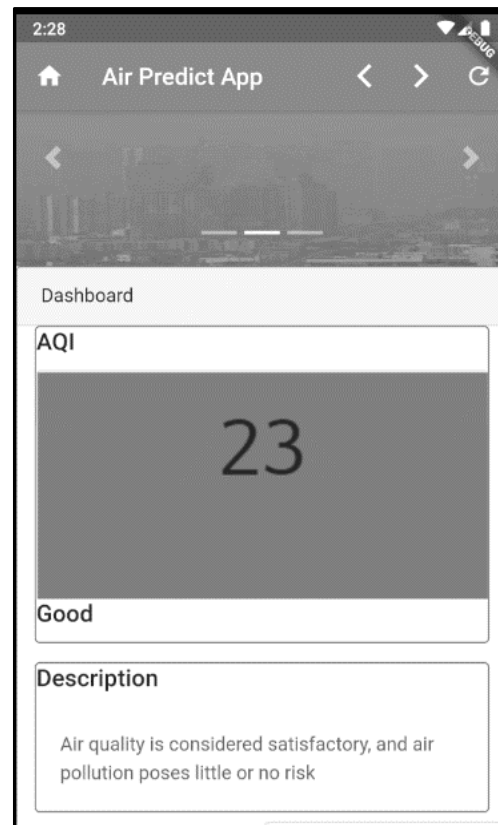

Figure 5. Dashboard page of Android mobile application

### D. Back-end & Front-end connection establishment phase

In this phase of the development process, the Flask (Welcome to Flask — Flask Documentation (1.1.x), 2020) web framework is proposed to establish the connection between the back-end and the front-end of the system.

### E. User notification method development phase In this phase

The system uses a push notification method to implement the notification process. It works with the mobile application based on the push notification concept with flutter and the firebase database. The push notification method needs only a preinstalled android app on the mobile phone. Then if the mobile phone has an internet connection, the user gets a notification from the mobile app when the admin enters the above input values to the system. Figure 6 shows the implementation of the notification method using a mobile application.

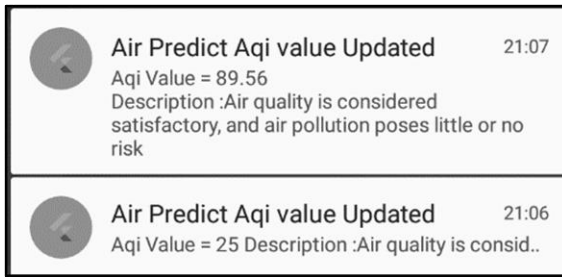

Figure 6. notification method using a mobile application

## Results Discussion and Conclusion

This paper presented the design and implementation of the ongoing developing system of the “Air Quality Predicting System for Colombo city” with the reviewing of existing systems and other related works to find out the best ML model with a suitable data collection method to predict the air pollution level in a specific city. Most of them have collected meteorological data from the Meteorological Department of their countries and some of them used datasets, they collected through IoT devices. But, some of these studies have shown the drawbacks of this type of system are facing in practice. Some of the datasets in the above research works are not large enough to train the algorithm and the Unavailability of some data cause some errors in the final air pollution prediction. After reviewing these systems, PM<sub>2.5</sub> air pollutant concentration level has been provided the higher accuracy for the prediction of the AQI value. Most of these PM<sub>2.5</sub> datasets have used regression type algorithms to predict the AQI value. Therefore the “Air Quality Predicting System for Colombo city” system has been used those data as an input to the system to predict AQI. Previous studies like, Jiangshe Zhang and Weifu Ding (Zhang and Ding, 2017) have used the Extreme Learning Machine (ELM) algorithm for predicting Air pollutant levels by analyzing data from eight quality parameters. But they got RMSE value = 14.3 and in our machine learning model have recorded RMSE = 8.58. And also, Bing-Chun Liu and others (Liu et al., 2017) have

aimed to present a model for the Air Quality Index (AQI) forecasting using collaborative multiple city air quality data as input and they used SVR algorithms for the predictions. They got RMSE and MAPE values less than 12. So, in our model, it has recorded RMSE and MAE values less than 9. Therefore, those points have shown, that our model is performed well on the PM<sub>2.5</sub> air pollutant concentration dataset and the simple linear regression algorithm. According to the linear type relationship between PM<sub>2.5</sub> value & the AQI value, it used a Simple Linear Regression type algorithm due to the lowest RMSE value with comparing to other types of machine learning approaches.

## Future Works

Still, the “Air Quality Predicting System for Colombo city” system is in the development stage. Therefore, it has to make a connection between the back-end and the front-end of the system for getting user inputs from mobile or web application and implements predicted AQI value with the summarized warning description on the dashboard page. And finally, it should evaluate the predicted results with the actual values to confirm the creativeness of the system.

## References

- National Building Research Organization (NBRO) (2017). AMBIENT AIR QUALITY IN 2017 – AT COLOMBO URBAN AREA. Colombo: NBRO, p.27.
- Air pollution levels rising in many of the world’s poorest cities [WWW Document], n.d. URL <https://www.who.int/news-room/detail/12-05-2016-air-pollution-levels-rising-in-many-of-the-world-s-poorest-cities> (accessed 10.18.19).
- Bougoudis, I., Demertzis, K., Iliadis, L., 2016. Fast and low cost prediction of extreme air pollution values with hybrid unsupervised learning. *Integr. Comput.-Aided Eng.* 23, 115–127. <https://doi.org/10/f8dt4t>
- Delavar, M., Gholami, A., Shiran, G., Rashidi, Y., Nakhaeizadeh, G., Fedra, K., Hatefi Afshar, S., 2019. A Novel Method for Improving Air Pollution Prediction Based on Machine Learning

Approaches: A Case Study Applied to the Capital City of Tehran. *ISPRS Int. J. Geo-Inf.* 8, 99. <https://doi.org/10/ggbbj5>

Elvitigala, C.S., Sudantha, B.H., 2017. Machine Learning Capable, IoT Air Pollution Monitoring System with Upgradable Sensor Array 6.

Kleine Deters, J., Zalakeviciute, R., Gonzalez, M., Rybarczyk, Y., 2017. Modeling PM 2.5 Urban Pollution Using Machine Learning and Selected Meteorological Parameters. *J. Electr. Comput. Eng.* 2017, 1–14. <https://doi.org/10/ggbghd>

Liu, B.-C., Binaykia, A., Chang, P.-C., Tiwari, M.K., Tsao, C.-C., 2017. Urban air quality forecasting based on multi-dimensional collaborative Support Vector Regression (SVR): A case study of Beijing-Tianjin-Shijiazhuang. *PLOS ONE* 12, e0179763. <https://doi.org/10/gbnhpn>

Mishra, A., 2018. Air Pollution Monitoring System based on IoT: Forecasting and Predictive Modeling using Machine Learning 8.

Pandey, G., Zhang, B., Jian, L., 2013. Predicting submicron air pollution indicators: a machine learning approach. *Environ. Sci. Process. Impacts* 15, 996. <https://doi.org/10/ggbdkb>

Vidya Vikas Institute of Engineering and Technology, C R, A., Deshmukh, C.R., D K, N., Gandhi, P., astu, V., 2018. Detection and Prediction of Air Pollution using Machine Learning Models. *Int. J. Eng. Trends Technol.* 59, 204–207. <https://doi.org/10/ggbbhp>

Wei, D., 2014. Predicting air pollution level in a specific city 5.

Zhang, J., Ding, W., 2017. Prediction of air pollutants concentration based on an extreme learning machine: the case of Hong Kong. *Int. J. Environ. Res. Public. Health* 14, 114. <https://doi.org/10/f9xt7w>

TensorFlow. 2020. Tensorflow Core | Machine Learning For Beginners And Experts. [online] Available at: <https://www.tensorflow.org/overview> [Accessed 26 July 2020].

Scikit-learn.org. 2020. Getting Started — Scikit-Learn 0.23.1 Documentation. [online] Available at: [https://scikit-learn.org/stable/getting\\_started.html](https://scikit-learn.org/stable/getting_started.html) [Accessed 26 July 2020].

Pandas.pydata.org. 2020. Getting Started — Pandas 1.0.5 Documentation. [online] Available at: [https://pandas.pydata.org/docs/getting\\_started/index.html](https://pandas.pydata.org/docs/getting_started/index.html) [Accessed 26 July 2020].

Firebase. 2020. Firebase. [online] Available at: [https://firebase.google.com/?gclid=CjwKCAjwi\\_b3BRAGEiwAemPNU7bljVeWSrgW1n9at\\_ADmKv9LN5WzfcZHprQXKXx2k27nDFn8MI6oBoCPUkQAvD\\_BwE](https://firebase.google.com/?gclid=CjwKCAjwi_b3BRAGEiwAemPNU7bljVeWSrgW1n9at_ADmKv9LN5WzfcZHprQXKXx2k27nDFn8MI6oBoCPUkQAvD_BwE) [Accessed 2 July 2020].

Medium. 2020. The Power Of Webviews In Flutter. [online] Available at: <https://medium.com/flutter/the-power-of-webviews-in-flutter-a56234b57df2> [Accessed 2 July 2020].

Flask.palletsprojects.com. 2020. Welcome To Flask — Flask Documentation (1.1.X). [online] Available at: <https://flask.palletsprojects.com/en/1.1.x/> [Accessed 26 July 2020].

### Author Biographies



MDCM Wijethunga is a final year Software Engineering undergraduate of the Faculty of Computing, General Sir John Kotelawala Defence University.



WMKS Ilmini is a probationary lecturer of the Department of Computer Science, Faculty of Computing, General Sir John Kotelawala Defence University.

Her research interests include Artificial Neural Networks, Deep Learning, Affective Computing, and Data Mining. She has produced more than 10 referred international and local publications to her credit. And also, she has won the Merit Award for Personality Detector in National ICT NBQSA 2019.

## Real-time Animal Detection and Prevention System for Crop Fields

R Lathesparan<sup>#</sup>, A Sharanjah, R Thushanth, S Kenurshan, MNM Nifras, and WU Wickramaarachi

*Department of computing, Rajarata University of Sri Lanka, Mihintale, Sri Lanka*

<sup>#</sup>lathesparan@gmail.com

**Abstract:** Every year, crop damaged by wild animals is dramatically increasing in Sri Lanka. It often poses risks to humans and animals. Since more and more wild animals are causing damage to their cultivation; humans could not tolerate it. Therefore, they require an effective mechanism to overcome this situation. With that background, the objective of this study is to detect wild animals before entering into the crop fields and implementing appropriate scare-away mechanisms in real-time. The presence of the animal will be sent to the farmer via a mobile application. In this study, two Convolutional Neural Network (CNN) classification models have been developed using the transfer learning approach with the VGG-16 as a pretrained model to detect elephants, wild boars, and buffalos. Both two models were combined and runs on Raspberry pi, which acts as the processing unit for the system, captures the images of animals, and predicts it. Whenever the presence of the animal senses by the thermal sensor which is installed on Arduino, it sends a trigger to capture the image. Based on the prediction sudden flashes of light, ultrasound, and bee sound will be produced to scare away the animals. The mobile application was developed using react native which is used to alert the user about the animal, connected through the Firebase database. The findings of this research indicate that the accuracy rate of the classification model is 77 percentage. This system significantly reduces human-animal conflict in crop fields by automatically implementing scare-away mechanisms based on the prediction.

**Keywords:** Animal Detection, Scare-away mechanism, User Alert, Convolutional Neural Network, IOT

### Introduction

In Sri Lanka, agriculture is one of the major economic forces. In 2018, the Gross Domestic Product (GDP) rate for agriculture was 7.8 percentage and generated Rupees 555,679 million. (Central Bank of Sri Lanka, 2018) Every year, thousands of human-animal conflicts caused numerous deaths, physical injuries, and loss of properties. Mostly, human-animal conflicts occur when animals raid crop fields in search of food. In particular, more deforestation contributed to a reduced amount of habitat for the animals, and they are forced to come out of their range to search for new habitats and food in farmlands. In fact, according to the agriculture ministry of Sri Lanka, it has been confirmed that 40 percentage of the annual crop is destroyed by wild animals. (Colombo Page, 2019) Commonly, crops are damaged by elephants, wild boars, monkeys, peacocks, squirrels, and porcupines. There have been many incidents in the past where the conflict between humans and animals has caused serious damage to crops and resulted in the loss of the economy and the lives of farmers and animals in Sri Lanka. Mostly, Farmers are depending on various methods which are traditional, legal, and some illegal methods to overcome wild animals' intrusion. For instance, they use gun fires and firecrackers to keep elephants away. In Sri Lanka, 225 elephants have been killed by farmers

annually since 2008 and elephants have killed about 60-80 people annually. (Jayantha, 2020) Illegal methods like trap guns, snares, crackers, and explosives are still in practice to kill wild boar, which also kills many other animals and even humans. Electrified wires are laid on paths used by animals, accidentally, humans get hurt when they come into contact with these electrified wires sometimes. Like these, various prevention methods are used against various animals. Some may be efficient and others result in injury to both humans and animals. Moreover, the prevention mechanism which was used by farmers is very expensive to implement as well as harmful to animals and humans' life, yet farmers often kill animals to protect their crops and life. To solve the problem, the system was developed that can detect wild animals entering the crop fields using CNN and implementing appropriate scare-away mechanisms in real-time. It will be done by alerting farmers through a mobile application about the presence of wild animals in their fields. The system will significantly reduce human-animal conflict in crop fields. Briefly, this system has been developed to minimize damages in the crop field, loss of human life, and destruction of animals. The scare-away mechanism helps to reduce the injury and death of animals in an eco-friendly manner. On the other hand, it protects the crop fields from harmful animals.

## Background and Related Works

### A. Animal Detection

Most of the animal detection systems developed based on deep learning is dominated by CNN. Deep learning implies a neural network with many layers, thus the numbers of the layer in architecture are referred to as the depth of the network. (Karen, 2015) CNN represents feed-forward neural networks which consist of three layers namely, the convolutional layer, the pooling layer, and fully connected layers.

(Norouzzadeh *et al.*, 2017) Convolutional layers act as an automatic feature extractor and it produces the feature map. Pooling layers act on the output of the convolutional layer to down sample them. Finally, in the fully connected layer neurons of the input feature maps are linked together with their internal neurons. (Saleh, Hossny and Nahavandi, 2018) To develop a CNN with higher accuracy and less amount of resources transfer learning is used widely. Transfer learning is a method of using previously learned weights in the base classification model as a starting point for current classification models. This reduces training time and resource utilization, providing higher levels of accuracy and reduces the amount of data required. (Willi *et al.*, 2019) In this study, VGG -16 is used as the base model to apply transfer learning. VGG -16 is one of the best computer vision model architecture. VGG-16 achieved 92.7% top-5 test accuracy on ImageNet, a dataset of over 14 million images from 1000 classes by using only 3x3 convolutional layers stacked on top of each other in increasing depth. Reducing volume size is handled by maxpooling layers of a 2x2 filter. Two fully connected layers, each with 4,096 nodes are then followed by a SoftMax classifier and it contains 1000 channels for each class. (Karen Simonyan, 2015)

### B. Animal Prevention

Many animal prevention methods have been existing for different kinds of animals since this study mainly focuses on elephants, wild boar, and buffalo. In Sri Lanka, scream noises, beat drums and trees, cracking whips used to scare away the elephants. (Santiapillai *et al.*, 2010) let bees live in the surrounding area of their field; when elephants try to pass through the barrier, bees will disperse and scream. (King, Douglas-Hamilton and Vollrath, 2007) Moreover, gunfire and firecrackers keep elephants away. Sometimes, pumpkins were filled with

poison and explosives and kept them in the field for the elephants to eat. It explodes when it has bitten and blows the elephant's mouth. Throwing boiling oil or burnt polythene onto elephants is also used against the elephant. (Jayantha, 2020) Buffalos normally move with many groups and the target on paddy, corn, mice, and some herbs. There are some methods such as making barriers using magnet tapes, monofilament threads. Commonly buffalos are scared of sudden lights and thunder sounds. (Pandey and Bajracharya, 2016) Apart from that, some of the traditional methods are used such as spraying local pigs' dung solution, burning of dried dung cakes, human hair as a deterrent, erection of used colored sarees, net wires with dense vegetation, planting of thorny bushes, xerophytes around the crop, creation of sound and light through the born fire, local dogs and using traps and poisoning for scaring away wild boars. There are some new methods also applied nowadays, like ultrasound, using guns, and electric fences. (Rao *et al.*, 2015) In general, whilst there are many traditional methods used currently. It is very easy to implement and maintain those traditional ways, as well as that are environmentally friendly. Such as bio fencing, stone fencing, trenches, watchtowers, throwing flaming sticks and rocks, making noises, and unpalatable vegetables are some of them. (Yaw OseiOwusu, 2008; Rao *et al.*, 2015; Pandey and Bajracharya, 2016) The usage of the electric barrier is very efficient, but it harms the animals, and death may occur for animals and humans in this method. (Ahlberg, 2016) Moreover, usage of honeybees' noise, ultrasound, and sudden flashes are eco (Ecology) -friendly, and cost-effective. (Pandey and Bajracharya, 2016)

### Classification Models

#### A. Data Set

The classification models have been trained using images of elephant, wild boar, buffalo,

chipmunk, goat, human, monkey, porcupine, rabbit, and rat. Once necessary images have been collected, images were manually filtered to select the images that only contain animals with a certain level of clarity. In total, 37,387 images were used. Approximately, 6000 images for elephants and 4000 images for each wild boar and buffalo were collected. Images were randomly split into a training set and a validation set to train the model. Out of total images, 80 percentage was used as a training set, and 20 percentage was used as a validation set. In addition to these images, 100 images per each class were collected to test the system.

#### B. Architecture

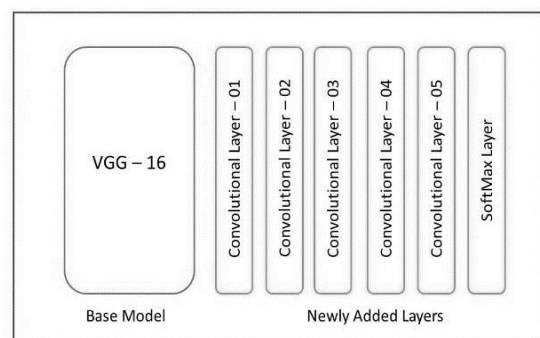

Figure 1: The layout of our CNN classification model

The data set was not large enough to develop a custom CNN classification model to address this transfer learning which has been used to get high accuracy with a small number of images. To implement transfer learning, the VGG-16 classification model was used as the base model. The layers of the classification model are shown in Figure

1. The fully connected layer of VGG 16 has been frozen and five more convolutional layers and a fully connected layer are added to implement transfer learning. Optimization algorithms are responsible for reducing the loss and provide an accurate result. Here, Adam Optimizer was used, which is computationally efficient and works well with a noisy and large amount of data. The model was trained with a learning rate of

0.001 along with 50 epochs and the batch size is 64.

### C. Implementation

Two classification models were trained. The Model-1 includes ten-classes that can predict elephant, wild boar, buffalo, chipmunk, goat, human, monkey, porcupine, rabbit, and rat. Model-2 is a three-classes classification model that can predict elephant, wild boar, and buffalo. It was used to increase the confidence of the prediction. The accuracy of the animal detection system has been improved by the combination of Model-1 and Model-2. Initially, the captured image passes through Model-1, and if that is classified as elephant or wild boar or buffalo, then predictions are supposed to choose the particular class. If not, images go through Model-2 then the probability of Model-1 and Model-2 are compared, and the highest value is obtained. The class with the highest probability value is assigned to a particular class. Combining these classification models could improve the accuracy of the model. However, it may increase the misidentification of other animals. Despite the probabilities of misidentification, the model's overall performance will not be affected as the system focuses only on the elephant, wild boar, and buffalo.

### Experimental Design

The proposed system contains software and hardware components; therefore, attention is given separately for those two components. In line with that, the software component has two main functions: animal detection and alerting the user. The hardware section has two main functions: implement an image capturing process and scare-away mechanism processes. The overall idea of the system will be implemented and follow the process as shown in Figure 2. The infrared thermometer continuously reads the temperature of the environment within its range. It will be

triggered by a temperature greater than or equal to 35°C. Then, the trigger is sent to the Raspberry Pi to capture the image and classify the image using the classification model. If that image is classified as elephant or buffalo or wild boar, an appropriate scare-away mechanism will be implemented to scare them away and the user will be alerted.

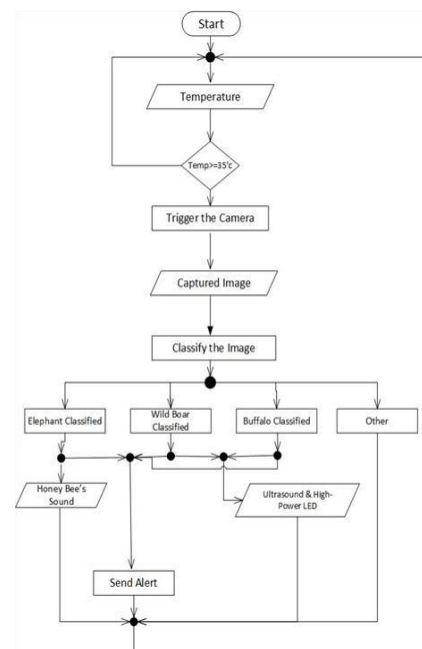

Figure 2: Flow chart of the system

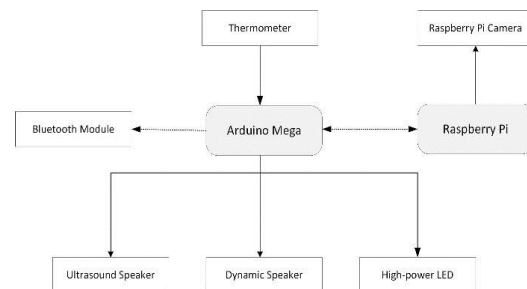

Figure 3: Hardware Components of the system

### A. Hardware Components

The whole system is built with two separate hardware components using the Raspberry Pi 3 Model B and the Arduino Mega 2560 R3 Board. The components of the temperature sensing mechanism and scare-away mechanism are connected to the Arduino, and the Raspberry Pi serves as a processing unit for detecting animals and used to the image capturing process. Both boards communicate with each other wirelessly via



using Bluetooth technologies. Figure 3 shows how components are connected to the Arduino Mega and Raspberry Pi. MLX960614 Infrared Thermometer, HC-05 Bluetooth

Module, Dynamic Speaker, Ultrasound Speaker, HighPower LED (Light Emitting Diode), and DFPlayer Mini were connected to Arduino Mega. Baud rate of 9600 bits/second is used to communicate with these components.

The Raspberry Pi camera module V2 is connected via the CSI (Camera Serial Interface) of Raspberry Pi. The MLX960614 infrared thermometer used to read the temperature of the environment and the body temperature of the animal. The HC-05 Bluetooth module can add twoway (full-duplex) wireless functionality. It has a transmission range of up to 10 m. Raspberry Pi Camera Module V2 is a high-quality 8-megapixel camera that can capture images of 3280 x 2464 pixels. Dynamic speaker, ultrasound speaker, high-power LED, and DFPlayer Mini used for scare-away mechanisms.

#### B. Image Capturing Process

The image capturing mechanism involves two hardware components, which are an infrared thermometer and a Raspberry pi camera. The infrared thermometer senses the temperature greater than or equal to 35°C, it sends a trigger to the camera to capture the image. 35°C was selected as the triggering temperature. The infrared thermometer reads the temperature almost every second, and when it reads a temperature higher than or equal to 35°C, it sends the raspberry upward trigger within 2 seconds. Once the trigger has been received, Raspberry Pi will capture the image. The captured image is saved as a jpeg (Joint Photographic Experts Group) format in the root folder of Raspberry Pi. An existing image will be replaced once a new image is captured.

#### C. Scare-away Mechanism

The following scare away mechanisms were identified since this study focuses on buffalos, wild boars, and elephants. The elephants can be frightened by the noise of bees, buffalos and wild boars can be frightened by sudden high beams of light and ultrasound. If an animal is classified as a wild boar or buffalo or elephant, the appropriate scare-away mechanism is applied for about 10 seconds after classification. If the elephant is detected, the dynamic speaker will emit the sound of honeybees, as well as if the wild boar or buffalo detects the ultrasound, and the sudden light emitted by the ultrasound speaker and highpower LED. The prediction result can be obtained from the Raspberry Pi to the Arduino via Bluetooth interconnection within one second after prediction and the scare-away mechanism starts working at the next second. The highpower LED emits, sudden flashes at a frequency of 15 Hz, and ultrasound emitted at 35000Hz.

#### D. Alert the User

An Android mobile application was developed using node.js to receive alerts from the system and let the user know about the detected animal. A single column real-time database was created with a firebase. The Firebase Realtime Database is a cloud-hosted, store, and sync data between users in real-time and developed by Google.

Whenever the animal is detected the predicted animal's details are sent to the firebase database and stored, by retrieving the stored information via the mobile application user can know which animal is predicted.

#### Result and Discussion

The findings are based on manual testing. Initially, the system was separately tested by each objective then, the whole system was manually tested by triggering the infrared

thermometer with human body temperature. In order to test, an image of the animal was placed in front of the camera. Once the animal's image was captured, it was classified. After the classification, the scare-away mechanism was successfully implemented. Meantime, the prediction result uploaded in the real-time database alerted the user.

#### A. Image Capturing Process

The effectiveness of the image capturing was assessed based on the infrared thermometer's capacity to sense the body temperature and triggering the process to capture the images. In every attempt, an infrared thermometer senses the body temperature when it was equal or greater than 35°C and the camera was triggered. It was observed that once the triggers were received the camera captured the images without any failures. According to the findings, the sensor tracked the animal's body temperature every second whenever an animal enters the region. Significantly, the system captured the image within 2 seconds after detecting the body temperature of the animal. Moreover, the python script effectively loaded and predicted the animal every time an image was captured.

#### B. Animal Detection Process

Hundred images were collected for each class and validated the classification model. A classification model was tested and evaluated at the level of prediction by testing each image to our classification model. The combination of two classification models detected elephants, buffalos, and wild boars with an average accuracy of seventy-seven percentage. Figure 4 shows the numbers of true positive predictions out of 100 images of each class animal. This model successfully detected 64 images of the wild boar, 78 images of the buffalo, and 89 images of the elephant out of 100 images of each animal. Most images were predicted as true-positive

even though few of them were obtained as true-negative. The Model-1 includes ten-classes with an average accuracy of 68.80%. The Model-2 is a three-classes with an average accuracy of 68.33%. Figure 5 shows the numbers of true positive predictions out of a hundred images of animals in each class of both model-1 and model-2. This shows that the prediction was improved in the combined classification model. Numbers of true positive prediction of wild boar in model-1 and model-2 is 41 and 54 respectively, it was improved to 64 in the combined model. Similarly, the true prediction of buffalo was improved to 78 from 62, and for elephants, it was improved to 89 from 85.

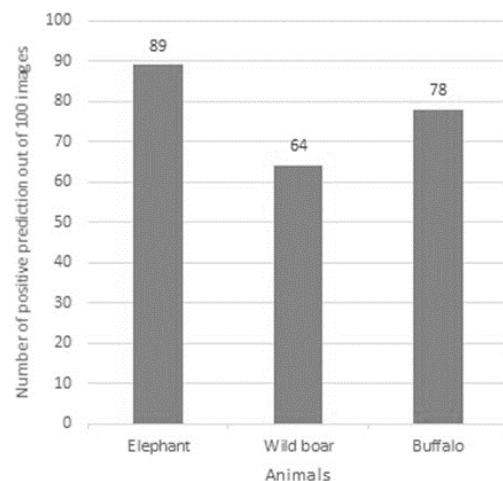

Figure 4: The number of true positive predictions out of 100 images for each class in the combined model

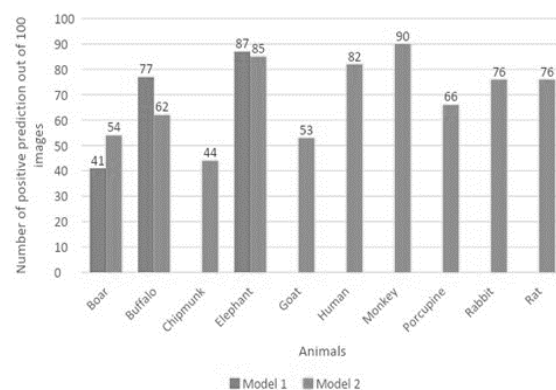

Figure 5: Number true positive prediction out of 100 images in Model-1 and Model-2

#### C. Scare-away Mechanism

The necessary inputs were manually given to test the scare away mechanism. The system

successfully understood the input and produced an appropriate scare-away mechanism. A scare-away mechanism was implemented for 10 seconds after the trigger of an appropriate scare-away mechanism was activated based on the detected animal. As per our testing, the scare away mechanism worked very well every time according to the prediction.

#### D. Alert the User

The system was built to send an alert to anyone who installed the mobile application. An alert was sent to the user's mobile application as soon as an animal was detected. At the instance of the detection of animals, information is saved into the firebase's real-time database. Figure 6 shows the screenshot of the alert messages when an elephant, buffalo, and wild boar were detected. We found that the user received the alert in real-time and effectively as a result of the internet based alert system. Since the system was based on the internet, the ability to receive an alert was not affected by the distance between the system and the user. However, the performance of the mobile application could vary based on the availability of the internet.

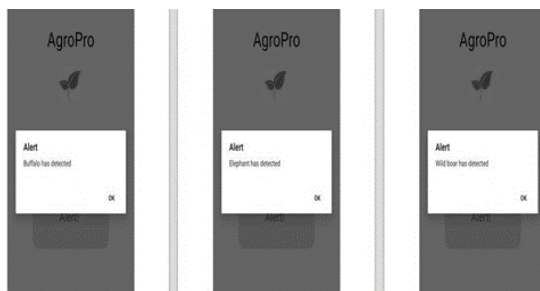

Figure 6: Screenshot of user alerts

#### Conclusion and Future Works

A large number of human-animal conflicts have been reported in the past, causing serious damage to the crop, downturn the economy, and mishap the lives of farmers and animals. With this background, there is a need to protect the crops from the animals, and to avoid harming the animals. The

system was proposed to address human and animal conflict. A real-time deep learning-based system was suggested for animal detection and prevention of human-animal conflicts in crop field areas. The system was developed to automatically detect and scare away elephants, buffalos, and wild boars. The system has been implemented to achieve three objectives: detecting animals, preventing animals from entering the field, and alerting the user. Briefly, when an animal with a temperature above 35°C entered the area where the infrared thermometer was placed, it sent a trigger to the camera. According to the trigger of the infrared thermometer, the camera took a picture of the animal. Once the picture was taken, the captured image was sent to the classification model to predict the animal. The output of the classification model implemented a relevant scare away mechanism, for example, a bee buzzing sound, ultrasound, or sudden flash of lights. At the same time, Details of the animals will be sent to the farmer through the mobile application. Our findings indicated that the detection system provided an average accuracy of 77%. It took approximately 40 seconds from sensing the temperature to a scare-away mechanism. The accuracy of the model can be affected by the amount of data that we have used. In this case, the number of images and the number of epochs may not sufficient enough. Along with that, the transfer learning approach may lead to overfitting, specifically, in the transfer learning method any pooling layer wasn't added, which also leads to overfitting.

Some advanced features can be added to improve the system and derive a better performance. Here, the accuracy of the current model can be increased by adding more layers and increase the number of epoch and the amount of dataset. Along with that, other architecture like resnet50, GoogleNet, and others can be used as a base model, which may perform more accurately.

Animal detection accuracy and numbers of animals can be improved using pre-trained APIs to reduce the limitations of the system. The efficiency of the thermometer could increase by alternating higher range sensing thermometers. It will be better to use a large number of cameras and sensors to acquire more efficiency and accuracy of the whole system. Moreover, by inserting a SIM (subscriber identity module) module, the system can send text messages whenever the internet becomes unavailable. In the future, a revised version of the system can be applied to address other human-animal conflicts. It could be modified to scare away other animals such as monkeys, porcupines, insects, and birds. Apart from this, it can be modified to protect villages and homes from wild animals by alarming and scaring away them before they enter the boundaries. Significantly, a modified version of the system can be used to alert drivers about animal crossing areas of major roads and railway crossings. The driver could be alerted about the presence of certain animals and ensure pedestrian safety. It can reduce road accidents caused by animals.

## References

- Ahlberg, N. (2016) Sri Lankan elephant – *Elephas maximus maximus*. Available at: <http://niclasahlberg.se/portfolio-item/srilankan-elephant-elephas-maximus-maximus/?lang=en> (Accessed: 10 August 2019).
- Central Bank of Sri Lanka (2018) Central Bank of Sri Lanka Annual Report 2018. Available at: <https://www.cbsl.gov.lk/en/publications/economic-and-financialreports/annual-reports/annual-report-2018>.
- Colombo Page (2019) Agriculture Ministry focuses on prevention of crop damage by wild animals, Colombo Page. Available at: [http://www.colombopage.com/archive\\_19A/Jan09\\_1547015707.CH.php](http://www.colombopage.com/archive_19A/Jan09_1547015707.CH.php) (Accessed: 13 March 2020).
- Jayantha, J. (2020) Human-wildlife conflicts in Sri Lanka, Sunday Observer. Available at: <https://www.sundayobserver.lk/2020/01/12/human-wildlifeconflicts-sri-lanka> (Accessed: 13 April 2020).
- Karen Simonyan, A. Z. (2015) 'very deep convolutional networks for large-scale image recognition', pp. 1–14.
- King, L. E., Douglas-Hamilton, I. and Vollrath, F. (2007) 'African elephants run from the sound of disturbed bees', *Current Biology*, 17(19). doi: 10.1016/j.cub.2007.07.038.
- Norouzzadeh, M. S. et al. (2017) 'Automatically identifying, counting, and describing wild animals in camera-trap images with deep learning', pp. 1–17. Available at: <http://arxiv.org/abs/1703.05830>.
- Pandey, S. and Bajracharya, S. B. (2016) 'Crop Protection and Its Effectiveness against Wildlife: A Case Study of Two Villages of Shivapuri National Park, Nepal', *Nepal Journal of Science and Technology*, 16(1), pp. 1–10. doi: 10.3126/njst.v16i1.14352.
- Rao, V. V. et al. (2015) 'Traditional management methods used to minimize wild boar (*Sus scrofa*) damage in different agricultural crops at Telangana state, India', *International Journal of Multidisciplinary Research and Development*, 2(2), pp. 32–36. Available at: [www.allsubjectjournal.com](http://www.allsubjectjournal.com).
- Saleh, K., Hossny, M. and Nahavandi, S. (2018) 'Effective vehicle-based kangaroo detection for collision warning systems using region-based convolutional networks', *Sensors (Switzerland)*, 18(6). doi: 10.3390/s18061913.
- Santiapillai, C. et al. (2010) 'An assessment of the humanelephant conflict in Sri Lanka', *Ceylon Journal of Science (Biological Sciences)*, 39(1), p. 21. doi: 10.4038/cjsbs.v39i1.2350.
- Willi, M. et al. (2019) 'Identifying animal species in camera trap images using deep learning and citizen science', *Methods in Ecology and Evolution*, 10(1), pp. 80–91. doi: 10.1111/2041210X.13099.

Yaw Osei-Owusu, L. B. (2008) 'Human-wildlife conflict: Elephant', Wildlife Management Working Paper, 11, p. 61.

### Acknowledgement

We greatly appreciate all lecturers and the supportive members of the academic and non-academic staff of the Information Technology degree program in the Department of Computing, Rajarata University of Sri Lanka for giving contribution to complete our study.

### Author Biographies



R Lathesparan is currently a BSc in IT undergraduate with the Department of Computing, Rajarata University of Sri Lanka. His research interests are

Artificial Intelligence and Machine Learning.



A Sharanjah is currently a BSc in IT undergraduate with the Department of Computing, Rajarata University of Sri Lanka. Her research interests

are deep learning, and image processing.



Thushanth is currently a BSc in IT undergraduate with the Department of Computing, Rajarata University of Sri Lanka. His research interests are deep learning and mobile computing.



Kenurshan is currently a BSc in IT undergraduate with the Department of Computing, Rajarata University of Sri Lanka. His research interests are deep learning and IOT.



M N M Nifras is currently a BSc in IT undergraduate with the Department of Computing, Rajarata University of Sri Lanka. His

research interests are IOT and mobile computing.



Wiraj Udara Wickramaarachchi is currently a Lecturer of the Department of Computing, Rajarata University of Sri Lanka. His research

interests are Biometrics, Information Security and, Image Processing. Currently he is pursuing his doctoral degree at Wuhan University of Technology, China.

## Diabetes Prediction System using Machine Learning

TK Thenabadu# and WMKS Ilmini

*Faculty of Computing, General Sir John Kotelawala Defence University, Ratmalana, Sri Lanka*

#thamindu@gmail.com

**Abstract:** Diabetes is a deadly chronic disease which affects entire body system harmfully. Millions of people are affected by this disease and a considerable number of patients die every year because of its side effects. A diabetic patient suffers from a high level of blood sugar in the body. Undiagnosed diabetes may cause the nerve and kidney damage, heart and blood vessel disease, slow healing of wounds, hearing impairment and several skin diseases. Early detection of diabetes is very essential to have a healthy life. The recent development of Machine Learning approaches solves this kind of critical problems. The main objective of this study is to present a Machine Learning based solution (Artificial Neural Network) to solve the above problem. And also, the technologies and approaches used in previous researches to predict diabetes have been reviewed with their accuracy levels. All the previous studies have used “Pima Indian Diabetes Dataset” (PIDD) as the dataset but this research is based on a newly collected dataset. The overall development process can be categorized into four major development phases namely data collection and preprocessing, statistical analysis, development of machine learning model and development of front-end. Artificial Neural Network model has been developed and deployed while the model provides more than 92% accuracy on the sample testing dataset.

**Keywords:** Diabetes, Machine Learning, Artificial Intelligence, Artificial Neural Network, Android, Tensorflow, Firebase

### Introduction

Diabetes is considered as one of the deadliest chronic diseases which can affect the entire body system adversely and there are millions of people affected by diabetes all over the world. According to WHO (Who.int, 2019), there were 422 million diabetes patients and it is 8.5% of the total population in the world. Diabetes increase the nerve and kidney damage, heart and blood vessel disease, slow healing of wounds, hearing impairment and also several skin diseases. In 2016, 1.6 million deaths were recorded because of diabetes. Almost half of all deaths occurred before the age of 70. According to WHO, diabetes was the 7th leading cause of death in 2016.

According to the research done by Katulanda and others (Katulanda et al., 2009), it is mentioned that by 2025 South East Asia will be the region with the highest number of diabetes patients in the world. Early identification of diabetes is important to have a healthy life. A healthy diet, regular exercises, maintaining average body weight, and eliminating alcohol and smoking are ways to prevent or delay the onset of type 2 diabetes. Diabetes can be controlled, and its consequences avoided or delayed with diet, physical exercises, medication and treatment for complications.

Machine Learning is an Artificial Intelligence application which provides systems with the ability to learn and improve from its own experience without being explicitly programmed. Previous studies which have been done to predict diabetes used some machine learning classification algorithms

such as Support Vector Machine (SVM), Decision Tree, Random Forest (RF), Naïve Bayes and Neural Network. All most all the previous studies have used “Pima Indian Diabetes Dataset” (PIDD) as the dataset. The performance of those various Machine Learning models has been reviewed in terms of accuracy and precision.

A new dataset has been collected to build the machine learning model and the related risk factors were originally discovered. Discovered risk factors are gender, age, BMI, waist circumference, frequency of doing exercises and having fruits/vegetables, high blood pressure, and risk score. This research aims to improve health care in Sri Lanka through, predicting diabetes at an early stage and giving recommendations to maintain a healthy life.

### Literature Review

According to the World Health Organization, (Who.int, 2019) diabetes has become a leading cause of death in the world. Most of the diabetes patients are in low- and middleincome countries. A lot of researches have been done specifically using Machine Learning and Neural Networks in diagnosing diabetes mellitus and some approaches are discussed including their aim, materials and methods used, results and conclusion.

Kaur and Kumari (Kaur and Kumari, 2018) have discussed “Predictive modelling and Analytics for Diabetes using Machine Learning” in their research paper. The main aim of that research was to find out what is the most accurate predictive model to predict diabetes mellitus among 5 predictive models which are known as “Linear Kernel” and “Radial Basis Function” (RBF), “Multifactor Dimensionality Reduction” (MDR), “k-Nearest Neighbor” (kNN), “Kernel Support Vector Machine” (SVM) and “Artificial Neural Network” (ANN). They have used R data manipulation tool to investigate the diabetes dataset, which is

known as Pima Indian Diabetes Dataset, originally owned by the “National institute of diabetes and digestive and kidney diseases”, India. This dataset contains 768 instances classified into two classes; diabetic and nondiabetic. And there are eight different risk factors. They have trained their model with 70% training data and tested with 30% remaining data. Those five different models developed using supervised learning methods mentioned above have been experimented in R programming studio.

Table 1: Accuracy of different Predictive models. (Kaur and Kumari, 2018)

No	Predictive Model	Accuracy
1	Linear Kernel SVM	0.89
2	Radial Basis Kernel SVM	0.84
3	k-NN	0.88
4	ANN	0.86
5	MDR	0.83

According to the above table, Linear Kernel SVM model is the most accurate model among those 5 predictive models.

From the above research, it can be said that “SVM-linear” and “k-NN” are the two best models to predict diabetes.

Zou and others (Zou et al., 2018) have discussed the “Prediction of Diabetes Mellitus with Machine Learning Techniques in their research paper”. The main objective of this study was to find out which is the most accurate machine learning technique to predict diabetes mellitus. Researchers have obtained two different datasets named as Luzhou dataset and Pima dataset. Luzhou dataset was obtained by the hospital physical examination data in Luzhou, China. And there are two parts of this dataset; healthy people and the diabetic people and it contains 14 different examination indexes. And the Pima dataset was the same as the previous research mentioned above. “Decision Tree” (DT), “Random Forest” (RF) and “Neural Networks” have been used as the

classifiers. DT and RF were implemented in WEKA while Neural Network was implemented in MATLAB. In this study, J48 decision tree was used in WEKA.

Table 2: Accuracy of different classifiers in Luzhou dataset. (Zou et al., 2018)

No	Classifier	Accuracy
1	Decision Tree (J48)	0.7853
2	Random Forest	0.8084
3	Neural Network	0.7841

Table 3 : Accuracy of different classifiers in Pima dataset. (Zou et al., 2018)

No	Classifier	Accuracy
1	Decision Tree (J48)	0.7275
2	Random Forest	0.7604
3	Neural Network	0.7667

By comparing the results of three classifications, there is not much difference among the three classifications, but random forest is better than other 2 classification methods. The value 0.8084 is the best accuracy in the Luzhou dataset while 0.7667 is the best accuracy in the Pima Indian dataset. And those results proved that machine learning can be used to predict diabetes.

Deepti Sisodia and Dilip Sisodia (Sisodia and Sisodia, 2018) have discussed the prediction of diabetes using Classification Algorithms namely Naïve Bayes, Decision Tree and SVM. The main objective of this study is to design a model which can predict the possibility of diabetes with maximum accuracy. Pima Indian Diabetes dataset used as the main dataset and WEKA Tool was used for data classification.

According to the above table, Naive Bayes classification is the most accurate classification comparatively other two algorithms.

Table 4 : Accuracy of different classifiers. (Sisodia and Sisodia, 2018)

No	Classifier	Accuracy
1	Naive Bayes	0.7630
2	SVM	0.6510
3	Decision Tree	0.7382

Pradhan and Sahu (Pradhan and Sahu, 2011) have observed using Artificial Neural Networks to predict diabetes. The main objective of this study was to find out what is the most accurate classification model to predict diabetes mellitus among 7 classification models which are known as FLANN (Functional Link Artificial Neural Network), Novel Artificial Neural Network, MFS1 (multiple feature subset), MFS2 (multiple feature subset), Nearest neighbors with NN, KNN, BSS. And Genetic Algorithm is used for feature selection and trained with Back Propagation algorithm.

Table 5: Accuracy of different classifiers. (Pradhan and Sahu, 2011)

No	Classifier	Accuracy
1	NN	0.651
2	kNN	0.697
3	BSS	0.677
4	MFS1	0.685
5	MFS2	0.705
6	Novel ANN	0.734
7	FLANN	0.598

According to the above table, it is revealed that their suggested Novel ANN is performing better compared to other 6 classification algorithms.

Saru and Subashree (Saru and Subashree, 2019) have discussed analyzing and predicting diabetes using Machine Learning. The main aim of this research was to find out which is the most accurate machine learning technique to predict diabetes mellitus among the selected classifiers. Pima Indian Diabetes Dataset was used as the dataset. Logistic regression with SVM, Decision tree(J48),



kNN(k=1) and k-NN(k=3) are the classifiers. According to the results, Decision tree(J48) has the highest accuracy of 0.944.

Islam and Jahan (Aminul and Jahan, 2017) also discussed various Machine Learning methods which can be used in diabetes prediction. The main aim of this research was to find out which is the most accurate machine learning technique to predict onset diabetes among the selected classifiers. Naïve Bayes (NB), Logistic Regression (LR), Multilayer perception (ML), Support Vector Machine (SVM), IBK, AdaBoostM1, Bagging, OneR, J48 and Random Forrest are the selected classifiers. Pima Indian Diabetes Dataset was used to train the models. According to the results, Logistic Regression performed the best accuracy among all 10 classifiers.

Sneha and Gangil (Sneha and Gangil, 2019) have researched the optimal features that can be used for early prediction of diabetes mellitus. The main aim of this study is to design a model which can predict the possibility of diabetes with maximum accuracy. SVM, Random Forest, NB, Decision Tree and KNN are the 5 classification algorithms used in this study and the used dataset was Pima Indian Diabetes dataset.

No	Predictive Model	Accuracy
1	SVM	0.7773
2	Random Forest	0.7539
3	NB	0.7348
4	Decision Tree	0.7318
5	KNN	0.6304

Table 6 : Accuracy of different classifiers. (Sneha and Gangil, 2019)

According to the above table, SVM has the highest accuracy compared to other 4 algorithms.

Table 7: Comparison of the best models of the papers

Paper	Best Model	Accuracy
Kaur and Kumari, 2018	Linear Kernel SVM	0.8900
Zou et al., 2018	Random Forest	0.8084
Sisodia and Sisodia, 2018	Naïve Bayes	0.7630
Pradhan and Sahu, 2011	Novel ANN	0.7340
Saru and Subashree, 2019	Decision Tree	0.9440
Aminul and Jahan, 2017	Logistic Regression	-
Sneha and Gangil, 2019	SVM	0.7773

All the previous researches mentioned in Table 7 is based on “Pima Indian Dataset”. Only the Machine Learning Methodologies and Models that have been selected are different from one research to another. Because of that, it is fair to compare the best models in each previous research to identify the best Machine Learning Model. According to the above table, it is clear that the Decision Tree in the 5<sup>th</sup> paper has the highest accuracy. But each model has its advantages, as well as disadvantages. And the accuracy level depends on the methodology which they have used.

## Methodology

### A. Anatomy of Diabetes Prediction System

This section discusses the design and the implementation of the Diabetes Prediction System which is being developed using Artificial Neural Networks. The system aims to improve the healthcare system in Sri Lanka through, predicting diabetes in an early stage and giving recommendations to maintain a healthy life. So, the most important function of the system should be the prediction part. The basic procedure of this system contains 3 major steps. First, the

user should enter some details through the mobile application. Then the backend of the system provides an accurate prediction based on the previously trained model. Finally, the system provides recommendations to the user to stay healthy. Figure 1 shows the overall solution for the research problem.

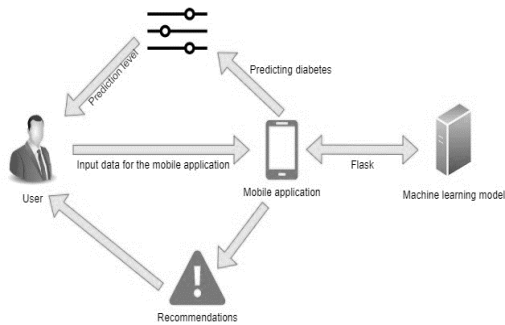

Figure 1: Overall solution diagram

The overall architecture of the system can be depicted as sub-systems such as problem identification and algorithm selection, data collection and training, prediction and finally the mobile application integration. Figure 2 shows the high-level architecture of the Diabetes Prediction System.

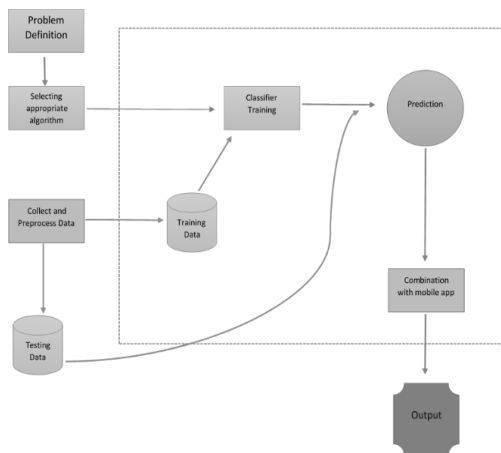

Figure 2: High-level architecture

The following use case diagram represents how the user interacts with the diabetes prediction system. The core of the system is the ANN model. The user can access the trained model through the Android application. The Android application should be able to predict the results according to the user inputs.

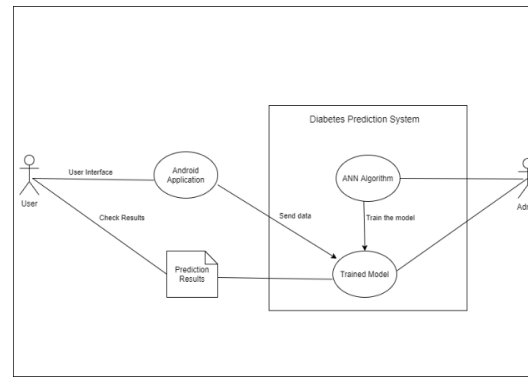

Figure 3: Use case diagram of the prediction system

## B. Overall Development Process

The overall development process can be categorized into four major development phases namely data collection and preprocessing, statistical analysis, development of machine learning model and development of front-end. A brief description of each development phase is given below.

### 1. Data collection and preprocessing

A sufficient amount of data needs to feed the Machine Learning algorithm to have good accuracy. Pima Indian Dataset, which has been used by previous research works, contains only female data which may not be able to predict diabetes of males. Because of that, it is decided to collect a dataset which is suitable for both male and female to predict diabetes and also the related risk factors have been originally discovered. Related risk factors were identified using the research done by Lindstrom and Tuomilehto related to a diabetes risk score of type 2 diabetes. (Lindstrom and Tuomilehto, 2003)

Google forms and printed surveys are used to collect the dataset. The collected dataset contains both male and female data of different age groups to balance the dataset

### 2. Statistical analysis

A correlation analysis has been done to check whether the selected risk factors are suitable for predicting Diabetes. According to Kumar and Chong “Correlation analysis is an

extensively used technique that identifies interesting relationships in data. These relationships help us realize the relevance of attributes concerning the target class to be predicted.”(Kumar and Chong, 2018). So, it is very important to do a correlation analysis to check whether the selected factors are connected in a way that can produce good accuracy in the model. R software, which is very useful in statistical analysis has been used to do the correlation analysis (Lafaye de Micheaux et al., 2013). Results of the statistical analysis are discussed under the results section.

#### Development of Machine Learning model

In this stage, the Artificial Neural Network based Machine Learning algorithm has used for predicting diabetes. Libraries like Tensorflow and Pandas are mostly used. After preprocessing the collected dataset, training and testing the model should be done. The generated model should be converted into a TensorFlow Lite model which can be implemented in the Android application. (TensorFlow Lite | ML for Mobile and Edge Devices, 2020)

ANN uses a sequential model which contains three dense layers. In the first layer there are 12 nodes and the activation function is ReLu. In the second layer there are 8 nodes and the activation function is ReLu. In the third layer there is only 1 node and the activation function is Sigmoid.

#### Development of Front-End

Since this is an android based research, the front-end is being developed using Android Studio. The authentication part has been done using Google Firebase (Khawas and Shah, 2018). Machine learning model conversion has been done using TensorFlow Lite. Main modules of the Android application would be Diabetes Info Center, Prediction module, Recommendation module, Diabetic Diet and User profile.



Figure 4: Prediction module user interfaces

## Results

### Statistical Analysis

Selected risk factors used in the statistical analysis are mentioned with their abbreviations below.

- GND – Gender
- AGE – Age
- BMI – Body Mass Index
- WC – Waist Circumference
- DE – Daily physical activities for at least 30 minutes? (including normal daily activities)
- FVD – How often do you eat fruits and vegetables?
- HBP – Have you ever taken medication for high blood pressure?
- HBG – Have you ever been found to have high blood glucose?
- RS – Risk Score
- DP – Diabetes Patient or not

A sample dataset has been plotted using R software and the correlation was calculated from 3 different methods. (Spearman Method, Kendall Method, Kendall Method). Related graphs for correlation analysis process is given below.

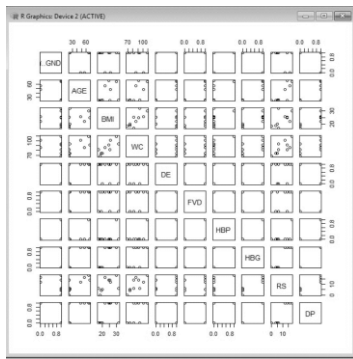

Figure 5: Plot of Risk Factors

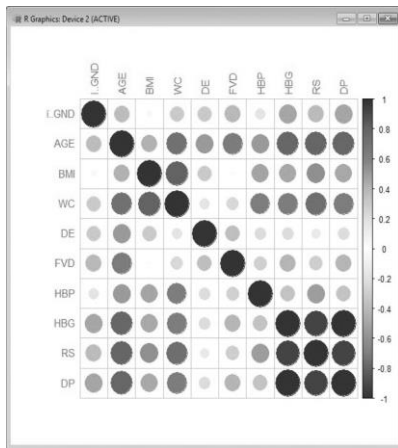

Figure 6: Correlation Analysis (Graphical)

According to the above diagrams, there are several strong correlations between risk factors. Because of that, the selected risk factors are suitable for use in the machine learning model.

### B. Machine Learning model

Results related to machine learning model can be categorized into two sub parts, accuracy on the training dataset and accuracy on the testing dataset which the model hasn't been seen before. Those accuracies calculated from collected dataset are mentioned below.

Accuracy on the training dataset = 93.65%

Accuracy on the testing dataset = 92.48%

According to the above graph, the ANN model has achieved 92.48% accuracy on the testing dataset. Pradhan and Sahu (Pradhan and Sahu, 2011) have observed using Artificial Neural Networks to predict diabetes but the achieved accuracy was 73.40%. Other researches discussed under

literature review, used different machine learning approaches to predict diabetes. (Table 7)

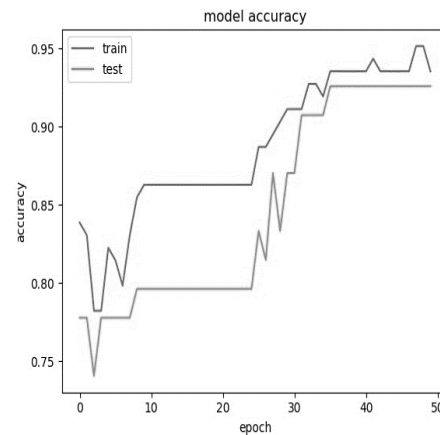

Figure 7: Training and Validation graph

### Discussion and Conclusion

Diabetes has no cure, but early detection of Diabetes can reduce severe health issues and the cost for medicine. Because of that, it is very important to predict it as soon as possible. This paper has reported our research on the use of an ANN in predicting type two diabetes. Several researches have been done research works to predict diabetes using Machine Learning techniques. "Pima Indian Diabetes Dataset" only contains 298 instances and it is not enough to build a strong predictive model. And, the dataset contains instances only about females. Because of that, the predictivity of diabetes for a male is not so accurate. Since this research has been done to predict diabetes of both males and females, instead of using PIMA Indian dataset, a new dataset has been collected. The overall development process can be categorized into 4 major development phases namely data collection and preprocessing, data analysis, development of machine learning model and development of front-end. By observing accuracy values of the machine learning model, it is clear that the developed ANN is usable of using in predicting diabetes of both males and females.

## Future Works

The research has not been completed yet. Only the data collection and machine learning model has been implemented in the Android environment. Prediction Module has implemented in the Android application. Features like recommendation system will be added to the Android application in the future. preprocessing, statistical analysis, development of the machine learning model have been completed.

## References

- Aminul, Md., Jahan, N., 2017. Prediction of Onset Diabetes using Machine Learning Techniques. *Int. J. Comput. Appl.* 180, 7–11.
- Diabetes [WWW Document], n.d. URL <https://www.who.int/westernpacific/health-topics/diabetes> (accessed 10.19.19).
- Katulanda, P., Sheriff, M., Matthews, D., 2009. The diabetes epidemic in Sri Lanka – a growing problem. *Ceylon Med. J.* 51, 26.
- Kaur, H., Kumari, V., 2018. Predictive modelling and analytics for diabetes using a machine learning approach. *Appl. Comput. Inform.* S221083271830365X.
- Khawas, C., Shah, P., 2018. Application of Firebase in Android App Development-A Study. *Int. J. Comput. Appl.* 179, 49–53.
- Kumar, S., Chong, I., 2018. Correlation Analysis to Identify the Effective Data in Machine Learning: Prediction of Depressive Disorder and Emotion States. *Int. J. Environ. Res. Public Health* 15, 2907.
- Lafaye de Micheaux, P., Drouilhet, R., Lique, B., 2013. *The R Software: Fundamentals of Programming and Statistical Analysis, Statistics and Computing*. Springer New York, New York, NY.
- Lindstrom, J., Tuomilehto, J., 2003. The Diabetes Risk Score: A practical tool to predict type 2 diabetes risk. *Diabetes Care* 26, 725–731.
- Pradhan, M., Sahu, D.R.K., 2011. Predict the onset of diabetes disease using Artificial Neural Network (ANN). *Emerg. Technol.* 2, 9.
- Saru, S., Subashree, S., 2019. ANALYSIS AND PREDICTION OF DIABETES USING MACHINE LEARNING 5, 9.
- Sisodia, D., Sisodia, D.S., 2018. Prediction of Diabetes using Classification Algorithms. *Procedia Comput. Sci.* 132, 1578–1585.
- Sneha, N., Gangil, T., 2019. Analysis of diabetes mellitus for early prediction using optimal features selection. *J. Big Data* 6, 13.
- TensorFlow Lite | ML for Mobile and Edge Devices [WWW Document], n.d. . TensorFlow. URL <https://www.tensorflow.org/lite> (accessed 7.24.20).
- Zou, Q., Qu, K., Luo, Y., Yin, D., Ju, Y., Tang, H., 2018. Predicting Diabetes Mellitus With Machine Learning Techniques. *Front. Genet.* 9, 515.

## Finger spelled Sign Language Translator for Deaf and Speech Impaired People in Srilanka using Convolutional Neural Network

HKK Perera#, DMR Kulasekara, Asela Gunasekara

*Department of Computer Science, General Sir John Kotelawala Defense University, Sri Lanka.*

#adorekasun@gmail.com

**Abstract:** Sign language is a visual language used by people with speech and hearing disabilities for communication in their daily conversation activities. It is completely an optical communication language through its native grammar. In this paper, hoping to present an optimal approach, whose major objective is to accomplish the transliteration of 24 static sign language alphabet words and numbers of Srilankan Sign Language into humanoid or machine decipherable English manuscript in the real-time environment. Since Srilanka has a native sign language deaf/Signers become uncomfortable when expressing their ideas to a normal person which is why this system is proposed. Artificial Neural Networks (ANN) and Support Vector machines (SVM) have been used as the technologies of this proposed system. Pre-processing operations of the signed input gestures are done in the first phase. In the next phase, the various region properties of the pre-processed gesture images are computed. In the final phase, based on the properties calculated of the earlier phase, the transliteration of signed gesture into text and voice is carried out. The proposed model is developed using Python and Python libraries like OpenCV, Keras, and Pickle.

**Keywords:** Artificial Neural Networks, Static gestures, Gesture recognition, Support Vector Machines, Gesture Classification

### Introduction

Now a day's technology has advanced to help people with any kind of disability. It almost makes IoT devices and there are robots to

help people in every situation. People who are suffering from hearing impairments, struggle daily in communicating their ideas to other people. Essentially to the oral language, sign language has a lexical, a "phonetic". (Saldaña González et al., 2018) (rather than verbalized sounds it has enunciated signs), a "phonology" (rather than phonemes, it has components from various natures that achieve a similar differential capacity from the words visual structure), punctuation, a semantic, and it's very own practice. Being a trademark from every nation and culture, and not widespread permits portraying all the truth that includes us, what users see, feel, or think. In order to fill that gap in Srilanka, Video Relay Service (VRS) (Gebre et al., 2014) is used in Srilanka for now. In VRS what happens is, a human interpreter translates the hand signs to Voice and the same is the inverse. The problem that lies there is that the communication speed is kind of slow and there is no privacy at all. Many researchers have been carried out to solve this problem in Srilanka, but the problem is that Srilankan sign language is not static. Meaning that the same word can be interpreted in many ways. Just as speakers have different voices, signers have different signs. (Gebre et al., 2014) And also the camera induces scale, translation, and rotation errors which may make noises. (Saldaña González et al., 2018)

This system is carried out using the camera, so the environmental conditions also affects but some systems don't care about the

environmental conditions because they are carried out with a wearable device.

Sri Lankan Sign Language (SSL) consists of 56 characters and overall, it has about 1000+ signs for now and its increasing day by day because people tend to form new signs for the words they use usually. According to the census results of housing 2012, there are a total of 569910 people including people with both hearing and speech impairments in Srilanka. Since the inability to convey the messages from the normal people and them they have lost the right to live a normal life. This paper suggests a method to solve that barrier and break the unfairness between the people. (Garcia and Viesca, n.d.) This system is proposed to find solutions for the following facts about the previous systems made.

- Environmental concerns.
- Occlusion (Detecting signs which are made from the reference box).
- Coarticulation (Signs are affected by the sign which is made before or after).

This proposed system only identifies the manual signs which are made by the hands (fingers). Taking ASL (American sign language) as a reference, where the dictionary contains 7154 sign words that visually look the same, which can lead to miscommunication. For example, signs for 'Chocolate' & 'Cleveland' are similar, they are not the same at least they cannot get even close. It is very hard to catch when a conversation is messed up (Mahesh Kumar et al., 2018). Basically, Communication via gesture recognition is a significant utilization of motion recognition. Gesture-based communication acknowledgment has two unique approaches.

1. Glove Based Approach
2. Vision-Based Approach

Mainly there are 2 main gesture types in Sinhala sign language. (Punchimudiyanse and Meegama, 2017) One is Conversational type, that has a set of sign gestures for common words and phrases which are made dynamically for the ease of use. And the second one uses fingerspelling alphabet to decode Sinhala words that are not there in the alphabet using letter by letter. For example, the word "Janaki/ජානකී" is spelled as J + A + N + A + K + I when converted to SSL its, ජ් + අ + න් + අ + ක් + ඉ.

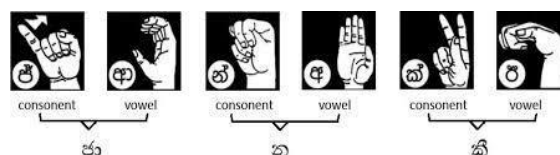

Figure 1: Sinhala Finger Spelling Word

Talking about the numbers in SSL, the basic numbers which normal people use is valid as it is and special number patters are available for,

- Numbers from 0 to 19.
- Signs from 20 to 90.
- Signs from 100 to 900.
- Signs for 1000, 100 000, Million and Billion.

The proposed system will help the deaf and speech impaired individuals in catching their sign-based message by means of the portable camera and afterward convert it into Sinhala content. Consequently, like average talking, it will be simple for them to speak with any individual at wherever and complete their work easily. Subsequently, the hardships they experience during the commitment to talk will be abridged.

This article is organized as follows: Section II presents the Related work on sign language recognition, Section III

Methods, and Approach, Section IV offers Design, Section V contains Results and

Evaluation and finally, section VI discusses the Conclusion and Future works.

### Related Works

Many types of research have been conducted in the field of Sign Language Recognition using various novel approaches. Such as skin filtering technique, use of gloves, use of Microsoft Kinect sensor for tracking hand, Fingertip Search method, Hu Moments method, Convolutional Neural Network (CNN), shape descriptors, Grid-Based Feature Extraction technique in feature extraction, and Artificial Neural Network (ANN), etc. Sign language recognition can be mainly categorized into 2 main parts as,

#### A. Manual Signs

Manual signs are the signs which are made from the hands. It can again be categorized into 2 main parts,

1) Vision-Based Recognition: Image processing algorithms are utilized in a Vision-based system to recognize and track hand signs and outward appearances of the signer. This system is simpler to the signer since there is no compelling reason to wear any additional equipment. Notwithstanding, there are exactness issues identified with image processing algorithms, and these issues are yet to be adjusted. There are two distinct methodologies in vision-based sign language acknowledgment:

1. 3D model based
2. Appearance-based

3D model-based techniques utilize 3D data of key components of the body parts. Utilizing this data, a few significant parameters, like palm position, joint edges and so forth., can be taken. This methodology utilizes volumetric or skeletal models or a mix of the two. The volumetric technique is more qualified for the PC animation field and PC Computer vision. This methodology is exceptionally computational concentrated and furthermore, frameworks for live

identification are still to be created (Escudeiro et al., 2014).

Appearance-based methods use images as information sources. A few formats are the deformable 2D layouts of the human pieces of the body, especially hands. The arrangements focus on the blueprint of an article called deformable layouts. This proposed system is an Appearance-based system. Some algorithms based on vision-based recognition are,

Support Vector Machine (SVM): American Sign Language recognition system which is proposed by Shivashankara (Department of Computer Science & Engineering, Sri Jayachamarajendra College of

Engineering, Mysuru, India et al., 2018) uses SVM for both numbers and letters and letters performed with an accuracy of 97.5% and numbers performed with an accuracy of 100%. Data was collected from the ASL which is a freely available dataset.

Artificial Neural Networks (ANN): Recognition and classification of sign language systems (Saldaña González et al., 2018) proposed for Spanish was made using a glove while also carrying the same project on artificial neural networks giving an accuracy for the Ann 90%. And giving an error rate of 2.61% which is independent of the user. The same paper presented a system using a glove and ANN which was 97% independent of the user.

Convolutional neural networks. (CNN): Real-time ASL recognition system with CNN (Garcia and Viesca, n.d.) proposes a system that compromises over 90% of accuracy without using any motion-tracking gloves. This also uses heuristics and the letter classification was done in ConvNet. Dataset was consisting of 65000, 150\*150px images each image with 2 of the same images which are color image and depth image.



SURF and Hu- Moment: Paper (Rekha Jayaprakash et al., 2011) combines Speeded Up Robust Features (SURF) and Hu-moment invariant methods to get the maximum features extracted from the image. The system has taken a dataset of 3 different backgrounds and environmental conditions and with 50 videos and a Total of 600 images, 400 negatives, and 200 positive images. Many Backgrounds were used here. Hand segmentation is done using the K Means clustering and skin color pixels are separated. To recognize the letters SURF and Hu moment is used while minimum Euclidean distance identifies the gesture. SIFT with KNN gave 68%, SURF with KNN gave 84.6% with 3 times faster. Word recognition accuracy was 96%. So overall SURF with KNN performed well.

2) Sensor-Based Recognition: Sensor-based recognition systems are those that were proposed to be made from the sensors which were made by a company like Microsoft Kinect. In this section, the signer wants to wear a glove before making his gestures. The disadvantage of this system is the signer always wants to wear the sensor hardware and the glove during the operation of the system.

Research and Implementation of a sign language recognition system using Kinect paper (Yuqian Chen and Wenhui Zhang, 2016) proposes a method that gives 89.6% accuracy by using relative distance, angle, and motion vector theories. The gesture was identified by the golden section search algorithm. Each word is signed by 7 signers each with 5 times color depth and skeleton info was taken by Kinect. The dataset was created using 25200 images and obtained the highest accuracy of 98.6% with a single hand and 70.3% with double hands.

From the above data, it can be concluded that the most accuracy is obtained through the vision-based approach and overall accuracy is good in convolution neural networks and

that's over 90%. And due to the hardships faced in using the glove-based method Srilankan culture won't fit in that. Here is a summary of the most relevant and effective steps that recent studies have conducted, on the Sign language recognition systems so far made using the visionbased method.

- Image Process: Manipulating the image to machine reprehensible format
- Edge Detection: To spot the dark side of the hand.
- Thresholding: Converting resourceful image to binary format
- Grey Scale: to acquire the full image without color variations.
- Training the Model: appending the images to the dataset to increase the accuracy.
- Making Predictions: Making predictions from the trained data on the live feed

## Methods and Approach

### A. Classifier Development

1) Algorithm Overview: Proposed SSL classification is finalizing utilizing a convolutional neural system (ConvNet / CNN). CNNs are AI algorithms that have seen amazing achievement in taking care of an assortment of assignments identified with preparing recordings and pictures. Recently, the field has encountered a blast of development and applications in picture classification and Object detection. An essential bit of leeway of using such procedures stems from CNNs capacities to learn includes just as the weights compared to each feature. Like other machine learning algorithms, CNNs look to enhance a few target functions, explicitly the loss function. Here, a SoftMax-based loss function is used:

$$Loss = \frac{1}{N} \sum_{i=1}^N -\log \left( \frac{e^{f_i, y_i}}{\sum_{j=1}^C e^{f_i, j}} \right) \quad (1)$$

$$f_j(z) = \frac{e^{z_j}}{\sum_{k=1}^C e^{z_k}} \quad (2)$$

N = total number of training examples  
 C = total number of classes

Figure 2: SoftMax Equation

Above shown is the SoftMax equation. To produce total SoftMax loss, the equation takes feature vector  $z$  for the given training data and separates its values to a format of  $[0,1]$  and that values go to the 1st equation. Then equation 01 gives mean a loss for each training data. Utilizing a SoftMax-based classification head permits us to yield estimates like probabilities for every SSL letter. This contrasts from another famous decision: the SVM loss. Utilizing an SVM classification would bring about scores for every ASL letter that would not straightforwardly guide to probabilities. These probabilities stood to us by the SoftMax loss permit us to more naturally decipher our results and demonstrate value when running our classifications through a language model.

2) Transfer Learning: It is the reusing of a model that is previously built for a problem that is related to the current problem. In deep learning, transfer learning is a procedure whereby a neural system model is first prepared on an issue like the issue that was already solved. At least one layer from the prepared model is then utilized in another model prepared on the issue of interest (at least one layer should be updated by changing parameters). The most essential case of this would be a completely prepared network whose last order layer weights have been changed to have the option to characterize a few new arrangements of data. The essential advantage of these methods is they require less time and fewer data processing. Notwithstanding, the test in

transfer learning comes from the contrasts between the first data used to prepare and the new data being characterized (new training dataset). Bigger deviation in these data sets regularly requires re-introducing or expanding learning rates for deeper layers in the net. In simpler words, it's using a pre-trained model. Perhaps the most popular pre-trained models are,

- 01.VGGnet which is also known as VGG16 or VGG19
- 02.Google Net (ex.Inception v3)
- 03.Residual Network. (Resnet50)

From the above mentioned pre-trained models, the proposed system uses the VGG net.

3) VGG (VGG16 or VGG19): VGG model was developed by a team called Visual Graphics group in oxford which is described in the paper (Garcia and Viesca, n.d.). mainly VGG has consistent and repeating steps that can integrate into the proposed model. By default, images should be scaled to  $224 \times 224$  squares but in this project, have modified and inserted images of  $96 \times 96$  px to increase the accuracy of the system.

#### B. General Techniques.

The main target of this phase is to finetune the VGG model according to the images which have got in the prepared SSL dataset. The data which is collected for this project is on 20 signs (since this is an ongoing project) which is completely different from one another in one class of dataset, it has got the same sign which is differentiated in backgrounds and different angles and orientations. Then to test the effectiveness of the system, changed the weights, depths, and stepped-up the learning rates of the neural network algorithm by a factor of 10 (roughly).

### C. Developing Pipeline

To take the Realtime signs done by the signer, made a desktop application and a mobile application where the desktop application uses OpenCV for capturing images and the mobile application uses java(android). when capturing images, the system captures images in frames and then sends the frame to the model and then takes the output of the model which is the prediction of what the sign is. When developing the model to fit the mobile application, first made the dataset and the model using the computer and then converted the model file (format:h5) to the 'tflite' format which can use it to the mobile application without any delay due to performance errors.

1) Model Design: In the proposed model, there is only one convolution layer and it has 32 kernels of size 3\*3 to extract features from the input image. And for the subsampling process, this convolution layer is then followed by a 3\*3 max pooling layer with a stride of 5. After pooling, the feature map obtained will be flattened into a vector and fed into the fully connected layer (FC layer). In order to classify the outputs, ReLU and SoftMax activation functions have been used in the FC layer. A dropout regularization of 20% has been used to cut off the images temporarily in each update cycle to reduce overfitting in the model. A diagram of the proposed model is given in Fig 3.

#### Design



Figure 3: Left-අඳ Middle-අඳ Right-අඳ

### A. Dataset Description

Datasets of this sign language can be mainly separated into 2 categories.

01.Color images

02.Depth images

To use depth images, it needs to have another camera that has depth sensors that are not available in most of the cameras as well as web cameras. So, used color images to develop the dataset. The dataset comprises 20 signs which are taken from 5 people and in many backgrounds. Altogether it contains about 50,000 RGB images. Some are closeups of the hand sign while some are a bit distanced. Since data of 5 people have been collected, have used a mixed combination to train, validate, and to test the data. To take the signs of the user in real-time made a different application that accesses the camera of the laptop and takes the video and then splits it into frames. it was made using python and OpenCV (cv2) and stores captured images in the local storage. Then again also took some photos using my mobile camera (12MP) and in there, one picture was around 5mbs which is too much for a dataset which took many gigs when completing the dataset. Therefore, it was decided to take a video the same as in the desktop version and split them to the frames in which one image was around 80kb. Mainly the dataset contains the static images of the Sinhala sign language.

1) Preprocessing Data: Since the images were taken by the video splitting have many errors like images are in different sizes and so on. Then changed the image size to 270\*480 px to match the input image size of the VGG net which has overwritten. furthermore, then made a horizontal flip to all images to take the right hand and left-hand effect. And, applied some zooming effect to the images to differentiate between the distances. Since the dataset needs to have

variety in it, also changed the qualities of the images, some were increased, and some were decreased. Most of the images are in the quality range of 65.5%.

- 2) Loading Dataset: The whole dataset was divided into three categories as train, validate, and test datasets. A ratio of 60:20:20 has been selected to separate out the train, validate and test datasets, respectively. To specify in terms of each hand sign, there were 1200 images in each training dataset, 400 images in each validate the dataset, and again 400 images in each test dataset.

### B. Cnn Model

- 1) Proposed Model:

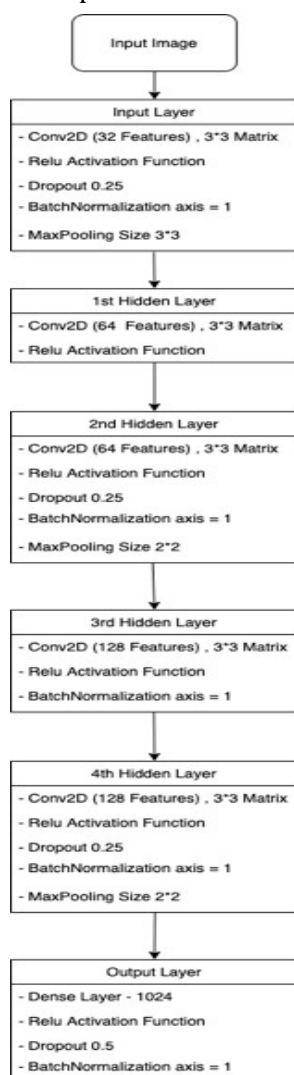

Figure 4: Architecture of the Proposed Model

- 2) Training and Validation Phase: Mainly the model was trained and tested many times by changing parameters and variables which the results are included in the results in the Results part. Main cases where I changed the parameters are,

- Number of features to be extracted
- Activation function
- Matrix Size in which the image is being classified.
- Dropouts size
- Number of Hidden Layers etc.

The main activation function which I used in the project is “Relu” and the matrix size is 3\*3.

- 3) Test Phase: The model I got after the training process freely as other common people in the society irrespective was tested with the images of the testing dataset which are of the language barrier. The technique pursues a vision completely different from the training dataset and gave based sign recognition framework to perceive static, good results.

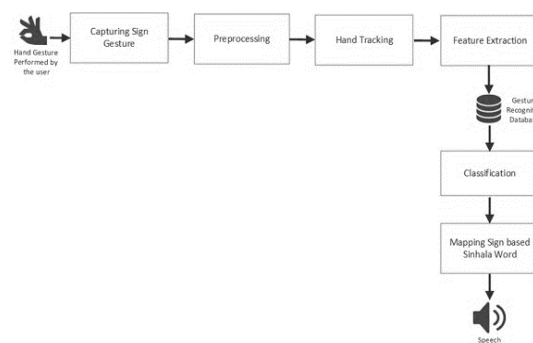

Figure 5 High-Level Architecture of Proposed System.

### Results and Evaluation

After checking the graph received for the first training using the separated frame images the validation accuracy was always around 3.54 while the training accuracy was 99.34% always. This was the overfitting condition faced in the dataset and then reduced some

images of the database to overcome the challenge. Initial Configs are as below,

- Epochs = 3, Batch Size = 32, Image dimensions = (96, 96, 3)
- Result: loss: 0.3269 - acc: 0.8870 - val\_loss: 0.0521 - val\_acc: 0.9827

To overcome the overfitting drop out of the final layer was increased from 0.25 to 0.5. And, the neurons of the final layer were also increased to 1024. Final configs are,

- Epochs = 8, Batch Size = 64, Image dimensions = (96, 96, 3)
- Result: loss: 0.0731 - acc: 0.9743 - val\_loss: 0.2114 - val\_acc: 0.9322

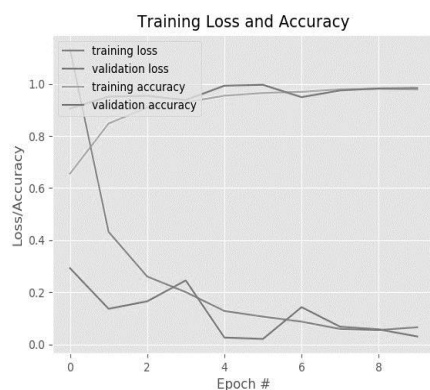

Figure 6: Final Model Details

## Conclusion and Future Works

The aim of this research is to develop a system for the deaf and speech impaired Sri Lankans and to help them behave dynamic, and fingerspelling expressions of SSL. This methodology is conservative and can be executed even with a portable camera which makes it very easy to use to be utilized by a typical man. The presentation of sign-based strategy created exceptional outcomes in unique motion acknowledgment. Because of the absence of accessibility of the dataset in SSL, another dataset is made which incorporates static gestures, dynamic gestures, and fingerspelling letters in order. Examination results show great acknowledgment precision for static and dynamic gestures, fingerspelling words, and

co-explanation discovery and disposal. On the way to solve that bigger problem, as the initial step, a system was built to recognize the static gestures of the Sinhala alphabet with the future of information procurement of hand gestures indicating NUI (Natural User Interfaces) utilizing profundity sensors.

## Acknowledgement

The authors would like to sincerely thank all who rendered their support in this study.

## References

- Athira, P.K., Sruthi, C.J., Lijiya, A., 2019. A Signer Independent Sign Language Recognition with Co-articulation Elimination from Live Videos: An Indian Scenario. J. King Saud Univ. - Comput. Inf. Sci. S131915781831228X. <https://doi.org/10.1016/j.jksuci.2019.05.002>
- Boulares, M., Jemni, M., 2012. Mobile sign language translation system for deaf community, in: Proceedings of the International Cross-Disciplinary Conference on Web Accessibility - W4A '12. Presented at the International Cross-Disciplinary Conference, ACM Press, Lyon, France, p. 1. <https://doi.org/10.1145/2207016.2207049>
- Department of Computer Science & Engineering, Sri Jayachamarajendra College of Engineering, Mysuru, India, S, Shivashankara, S, Srinath, 2018. American Sign Language Recognition System: An Optimal Approach. Int. J. Image Graph. Signal Process. 10, 18–30. <https://doi.org/10.5815/ijigsp.2018.08.03>
- Escudeiro, P., Escudeiro, N., Reis, R., Barbosa, M., Bidarra, J., Gouveia, B., 2014. Automatic Sign Language Translator Model. Adv. Sci. Lett. 20, 531–533. <https://doi.org/10.1166/asl.2014.5344>
- Garcia, B., Viesca, S.A., n.d. Real-time American Sign Language Recognition with Convolutional Neural Networks 8.
- Gebre, B.G., Crasborn, O., Wittenburg, P., Drude, S., Heskes, T., 2014. Unsupervised Feature Learning for Visual Sign Language Identification, in Proceedings of the 52nd Annual Meeting of the Association for Computational Linguistics (Volume 2: Short Papers). Presented at the Proceedings of the 52nd Annual Meeting of the Association for Computational Linguistics (Volume 2: Short Papers), Association for Computational Linguistics, Baltimore, Maryland, pp. 370–376. <https://doi.org/10.3115/v1/P14-2061>

Gebre, B.G., Wittenburg, P., Heskes, T., 2013. Automatic sign language identification, in 2013 IEEE International Conference on Image Processing. Presented at the 2013 20th IEEE International Conference on Image Processing (ICIP), IEEE, Melbourne, Australia, pp.

2626–2630.

<https://doi.org/10.1109/ICIP.2013.6738541>

Joslin, C., El-Sawah, A., Qing Chen, Georganas, N., 2005. Dynamic Gesture Recognition, in 2005 IEEE Instrumentation and Measurement Technology Conference Proceedings. Presented at the 2005 IEEE Instrumentation and Measurement Technology, IEEE, Ottawa, ON, Canada, pp. 1706–1711.

<https://doi.org/10.1109/IMTC.2005.1604461>

Kishore, P.V.V., Rajesh Kumar, P., 2012. A Video-Based Indian Sign Language Recognition System (INSLR) Using Wavelet Transform and Fuzzy Logic. *Int. J. Eng. Technol.* 4, 537–542. <https://doi.org/10.7763/IJET.2012.V4.427>

[No title found], n.d. . *Int. J. Adv. Res. Comput. Sci. Softw. Eng.*

Parcheta, Z., Martinez Hinarejos, C.D., 2018. Sign Language Gesture Classification using Neural Networks, in: *IberSPEECH 2018*. Presented at the *IberSPEECH 2018*, ISCA, pp. 127–131.

<https://doi.org/10.21437/IberSPEECH.2018-27>

Saldaña González, G., Cerezo Sánchez, J., Bustillo Díaz, M.M., Ata Pérez, A., 2018. Recognition and Classification of Sign Language for Spanish. *Comput. Sist.* 22. <https://doi.org/10.13053/cys-22-1-2780>

Yuqian Chen, Wenhui Zhang, 2016. Research and implementation of sign language recognition method based on Kinect, in: *2016 2nd IEEE International Conference on Computer and Communications (ICCC)*. Presented at the 2016 2nd IEEE International Conference on Computer and Communications (ICCC), IEEE, Chengdu, China, pp. 1947–1951.

<https://doi.org/10.1109/CompComm.2016.7925041>

Punchimudiyanse, M., Meegama, R.G.N., 2017. Animation of Fingerspelled Words and Number Signs of the Sinhala Sign Language. *ACM Trans.*

*Asian LowResour. Lang. Inf. Process.* 16, 1–26. <https://doi.org/10.1145/3092743>

### Author Biographies



Kalhara Perera is a final year undergraduate of Kotelawala Defense university who is a passionate researcher of image processing and machine learning technologies. And, he is a Software Engineering intern at Epic Technology Group. His Final Year individual Project is also based on a Sinhala Sign Language translator.

## Automated Generation of Sinhala Lyrics using Recurrent Neural Networks

Sheng Kao<sup>#</sup> and Kalani Ilmini

*Department of Computer Science, Faculty of Computing, General Sir John Kotelawala Defence University,  
Ratmalana, Sri Lanka*

<sup>#</sup>fushenkao@gmail.com

**Abstract:** This paper discusses the approaches involved in implementing automated song lyrics system in the Sinhala language. Which includes an overview of the complexity of writing song lyrics and develop an automated application for Sinhala song lyrics generation. Before the implementation was carried out, a set of Sinhala song lyrics has been collected to create a corpus, and it has been used to develop an RNN model with LSTM layers using different temperatures and epochs. Then the created models were used to carry out a comparison process to evaluate the effect of the corpus size and the number of epochs per model training to get a better understanding of the RNN training behaviors. Finally, the system was served to a web host to give the user a friendly UI, where the user can enter desired keywords and generate new Sinhala song lyrics. The initial results were obtained through different models and we could see that with the increment of the number of epochs and the number of song lyrics that are trained in each model, the generated output had a clear growth in terms of accuracy and meaning of the song.

**Keywords:** Recurrent Neural Networks, Deep Learning, Lyrics Generation, LSTM

### Introduction

From the very dawn of the human race, there has been one of the oldest arts that ever existed, which is, Music. It is a universal language that anyone can understand regardless of age, religion, gender, nationality, language, race, or skin color.

Despite the booming entertainment industry today, for many people music production and songwriting have become professionalism. Currently, the singers in the music industry have faced an issue where they have to release songs at a quick rate to keep up in the industry since it has become more demanding than ever before. And together with music creation comes songwriting. Composing lyrics has consistently been a provoking assignment to new musicians or individuals who have the enthusiasm to get compose their self-written lyrics as a music lover, as it includes imagination as well as motivation. Numerous forthcoming lyricists and individuals who are energetic about songwriting additionally need a launch or a motivation, to begin with. The system that is supposed to be built will be a helping hand to this problem, which could become a very helpful resource for musicians and especially for the songwriters. Also, nowadays the lyrics of most of Sinhala songs have been very poor in value and in quality too.

One of the main issues of building a generating system in the Sinhala language is dealing with morphology, syntax, and semantics. Because it is much more complex compared to the English language. (Especially with ස්වර පිල්ලම්, සන්ධි in Sinhala) Also, make them correct and accurate to generate meaningful sentences or phrases. This automated lyrics generating system will be some assistance to this issue, which will be the possibility to turn into an exceptionally compelling system for lyricists and performers. Also finding a large corpus

of Sinhala song lyrics is impossible while most English song corpora are readily available to download in an instant. This becomes a subproblem when digging into this project.

So, the system is supposed to be built using Recurrent

Neural Networks (RNN) with the aid of Long-Short-TermMemory (LSTM) layers. This creation of Sinhala lyrics corpus will be the first task to complete. The user will be enabled to enter a few keywords as his desire according to the topic the person wants to generate lyrics, then the system is supposed to generate lines of Sinhala lyrics according to the keywords given. It can be further developed to let the user choose the desired type of lyricist and generate lyrics according to the selected lyricist.

Many lyrics generating systems have been tried to create using LSTM and some of them are successful. But all of them are either in English, Chinese or some type of a widely used/popular language. But this research is going to be in Sinhala language and it's in a completely different grammar structure compared to the existing system languages' grammar structure. So, this will be a research conducted to test whether the use of LSTM networks can perform to generate lyrics in a complex language like Sinhala as well.

The rest of the paper is organized as follows, section II includes literature review, sections III includes technologies, section IV describes the implementation, section v includes results and evaluation and finally section VI discusses the conclusion of the project.

## Literature Review

### A. Lyrics generator with the use of rhythm

This system by Hugo R. and others (Oliveira, Cardoso and Pereira, 2007) was named as Tra-la-la-lyrics that is intended according to a specific pre-generated melody for the generation of lyrics. They researched the

relationship between phrases, musical beats of melodies and rhymes. They introduced numerous algorithms by using Java that divided the syllables and it could extract the 'syllabic stress' on a specific word. They also developed an SQL database that was intended to store words and grammar type. As they mentioned they could not achieve the results as they expected.

### B. Generating rap lyrics

By Nguyen and Sa, a Rap Lyrics Generator was developed (Nguyen and Brian Sa, 2009). The software consisted of a collection of about forty thousand recorded rap lyrics. The words and verses were used in existing lyrics then generate a new lyric. The lyrics were made using a linear-interpolated tri-gram model technique. The result has, however, been graded as lacking flow. Hence, they have shifted the model into a quad-gram model from a tri-gram model. They also introduced a corpus of rhyming words in a MySQL database, containing two separate sentences. They have built sentences that rhyme with each other in this way. Ultimately, All the sentences were brought together according to the song's form and style.

### C. Automated generation of poems

This system which includes natural language generation (NLG) techniques is the first poem generating system using artificial intelligence where it was developed by, Hisar Maruli, and others (Maruli Manurung, Graeme and Thompson, 2000). They named the implemented system as WASP (Wishful Automatic Spanish Poet). The program collects user inputs and consumed them as seeds. They used a Stochastic Hillclimbing Model because the creative element of the generation of poetry seems perfectly suited to a method with a certain element of randomness. The system is based on a forward reasoning ruled-based system. Even though the sample outputs showed that the



stochastic hillclimbing search model is effective in producing text, results obtained have been evaluated as weak and not very productive.

D. Determining Semantic similarity in song lyrics To identify and classify music automatically and to determine artistic similarity, Logan, and others experimented with the use of lyrics around 400 artists (Logan, Kositsky and Moreno, 2004). On the internet, song lyrics have been collected from different sources. Different techniques such as Probabilistic Latent Semantic Analysis (PLSA) and methods of clustering k-means were used to identify and extract content and semantics. The evaluation was performed by comparing the system to another audio system to test the similarities. Both PLSA and K-nearest clustering methods had their advantages as well as disadvantages. So they have suggested a mix of the both methods which will provide much better results and it was mentioned in their future works.

#### E. LyriCloud and Titular

Burr Settles (Settles, 2010) created two software tools named Titular and LyriCloud which built for songwriters and musicians intending to create an artificial intelligent lyric generating system. A set of words related to the input seeds were suggested by LyriCloud, while the semiautomatic generation of song titles were provided by the Titular system. A technique based on templates was employed with the aid of a database which contains the existing song titles. Rude, slang and insulting phrases have been stripped out, and words that feature in the database more often would most definitely enter the output song title generated. They obtained good results, but there was still no semantic sense in the titles and the readers didn't had much of an understanding of the output.

#### F. Lyrics generation with NLP

By using basic natural language processing tools, Mahedero, and others (Mahedero et al., 2005) analyzed song lyrics. Lyrics have experimented so that the languages were known, categorized according to different topics, and the structure extracted, and similarities were sought among them. Selected from various websites was a list of 500 lyrics English, German, Spanish, French and Italian were the languages included. They succeeded to achieve a 92% accuracy from the results gained. A Naive Bayes classification has been deployed. The Inverse Document Frequency (IDF) was used to calculate similarity in long with cos distance (Cosine value of the distance measured). The similarity was assessed. Relative to the other researches, it was concluded that it is easier to identify the languages by these techniques.

G. Lyrics Classifier based on rhyme and style Rudolf and others (Mayer, Neumayer and Rauber, 2008) experimented with the characteristics of lyrics using the rhyme and style of a song. They managed to use statistical features to process lyrics with the aid of a bunch of words with POS (Parts-of-speech) tagging. Basically, two words which can sound similar when spelled are called as a rhyme. This feature is often used in the end of a verse. They performed experiments for a test collection of 397 song lyrics with Naive Bayes, k-Nearest Neighbor classifiers, and SVMs with linear and polynomial kernels. By all three classifiers, SVM classifier results given the best result of all experiments.

#### H. Generating Sega lyrics automatically

In the Mauritian criollo language, Didoral and Pudaruth (Pudaruth, Bhaukaurally and Didorally, 2012) worked to develop a lyrical tool for generating Sega lyrics. The results were given to 63 people to identify whether the given 10 songs are either written by a man or a whether it is generated by a computer. Five of them were computer-

generated out of these 10 songs. However, the lyrics generated were in a very high standard because about almost half (50% of the participants) were uncertain about whether the lyrics were already existing or computer-generated. The main fault of this work is that there is no information on how the phrases are actually created or generated in the implementation section.

#### I. Essay Generation for a given topic

Xiaocheng and others (Feng et al., 2018) have developed an essay generating system in the Chinese Language. They thought to test their progress towards artificial intelligence would be a compelling way if they managed to create a computer program to generate essays automatically. To overcome common natural language generation challenges, they develop a multi-topic-aware long short-term memory (MTA-LSTM) approach for essay generation. Since there was no huge dataset to be tested, they have constructed two datasets of essays written in Chinese. The length of the produced essay was found to not affect the quality of the essay, also the final outcome of the methods they used were not very strong. Concluded as duplication and selfcontradiction of phrases were the main issues in the system.

#### J. Generating lyrics with LSTM

Depending on a particular artist's style, a lyrics generating system was developed by Olga, and others (Vechtomova et al., no date). The system has used a variational autoencoder with artist embeddings. They created a corpus of lyrics by picking seven artists. And they are picked on the basis of selecting one from each genre type. They trained a Convolutional Neural Network (CNN) classifier to predict artists. It was based on MEL spectrograms of their song clips. The initial findings discovered by the spectrogram classifier indicated that there is a gain in implementing the embedding of artists with the depictions. The final results

indicated that except for one case, the generated results were satisfying, and related to the artists' style most of the time.

#### K. Word-Embedded for Text Classifier

Using machine learning to automate text classification will make the whole process super-fast and efficient was the motivation for Ya-Chuan and Chia-Wei (Huang, 2016) to build a text classifier with word-embedded. They adopted the Convolution Neural Network (CNN) without pre-trained words embedded on IMDb movie review data and evaluate with the baseline Naive Bayes Classifier to prove that their CNN algorithm works. developed model focus on extracting the sentiment from the 20 Newsgroups dataset so they could find the accurate category of the input news. They concluded that Naive Bayes outperformed CNN in such a simple task, but when it moves to a more complex task, the generative model NB has decreased dramatically. They have mentioned using Recurrent Neural Network (RNN) would be the perfect way to use neural networks over such a sequence of data.

#### L. Text Generation using Recurrent Neural Networks

Since text generating is difficult to perform by using Hidden Markov Models and Markov Chains, Partiksha and Karun (Taneja and Verma, 2017) have decided to use Recurrent Neural Networks (RNN) with its variants LSTM and GRU to develop a language model so that can generate whole new text word by word automatically. They have trained different RNN in two stages. First is the training of simple RNN, LSTM, and GRU on different datasets and in the second stage sampling them is done to generate the output text. They have implemented 5 different datasets as input and trained all threw network according to them. Then 15 models gave been generated text as output. By the results, they concluded that the performance

is based on the input text and GRU performed better as it generated more realistic text and training loss was smallest in GRU.

M. Automatic Generation of News comments  
Hai-Tao and others (Zheng et al., 2018) have developed a system to automatic generation of news comments since they found out that it was not studied well in Natural Language Generation field. This task included the contextual connection with real-world news. So, to accomplish this they have decided to use a Gated Attention Neural Network model (GANN) to generate news comments. Also, to produce feedback with various topics and related grades, they used some arbitrary samples of data. To different perplexity scores, they showed that GANN is outperforming current word generation methods. The evaluation was done by using several human resources and the results were hardly distinguishable with real-world news comments and the generated ones.

#### N. Generating Text with Multiplicative Recurrent Neural Networks

Hessian-free optimization have achieved to outperform the obstacles with RNN trainings regarding to the other optimization methods. So, Ilya and others (Sutskever, Martens, and Hinton, 2011) decided to use it solve challenging sequence problems. And they have decided to develop a system to generate text using the variant of RNN, which is Multiplicative Recurrent Neural Networks (MRNN). The RNNs were trained using the Hessian-Free optimizer (HF) by applying them to character-level language modeling tasks. And they have trained them for five straight days on eight high-end GPU's. From the results they have concluded in contrast, the MRNN's nonlinear dynamics enabled to extract higher-level "knowledge" from the text and have produced better results compared to previous systems.

Summarized comparison of the most relatable works to this research has been discussed in the following Table 1.

By comparing and contrasting the technologies and the results of the above mentioned related works, it can be decided that the most suited approach to this project would be to use Recurrent Neural Networks (RNN) over the Conventional Neural Networks (CNN) and also other methods. CNN is best fitted to classify text data and has given better results but lacked in quality of text generation. While RNN has performed far better than CNN and other methods to generate text even though the training time is higher and complex in implementing.

Table 1: Comparison of the Literature Review

Work	Aim	Technology	Result
Tra-la-lalyrics	Generate lyrics for given melodies	Used three strategy Algorithms in Java, MySQL as a database engine	Generated lyrics with some meaning from three strategies but, there were no explicit semantics in the output
Rap Lyrics Generator	Outputs a rap song based on the words from the corpus	Linearinterpolated Tri-gram Model & Quad-gram model with MySQL database	Produces sentences that are usually grammatically correct, but not meaningful enough
Computational Creativity Tools for Songwriters	Create intelligent and interactive lyrics writing tools	Semantic networks and templatebased approach to title synthesis	Better results than previous generating tools but titles didn't have semantic meaning
Natural Language Processing of Lyrics	Experiment on the use of standard natural language processing (NLP) tools for the analysis of music lyrics	Ted Dunning' statistical identification algorithm to identify language and NLP techniques	The results made believe that NLP techniques can be successfully used for the creation of extensive ground truth metadata of lyrics
A SemiAutomated Lyrics Generation Tool for Mauritian Sega	Develop a lyrical tool for generating Sega lyrics (a major form of art of the Mascarene islands)	Implemented in PHP: and MySQL as a database engine	48.15 % of people thought that semigenerated lyrics were written by human beings
Generating lyrics with LSTM	Generating song lyrics lines depending on a particular artist's style	CNN classifier with LSTM and MEL spectrograms	Generated lyrics related to the artists' style most of the time.
Generating Text with Recurrent Neural Networks	Demonstrate the power of large RNNs trained to computergenerate text	Recurrent Neural Networks (RNNs) with the HessianFree optimizer (HF)	Represented the largest recurrent neural network application to the published date and produced surprisingly good language models

## Technologies

We will explore some context information in this segment of the main technologies used to build the lyrics generating system.

### A. Recurrent Neural Network (RNN)

Recurrent Neural Networks have shown

promising results in the field of AI especially in machine translation tasks (Liu et al., no date). In comparison to feedforward neural networks, RNNs are capable of controlling the feedback of a Sequence of variable length by having a recurrent hidden state in which each activation depends on the previous

period. The below diagram describes an RNN, which is being unfolded to a full network. If we take an example of a sentence of four terms, the network will be unrolled into a neural network of four layers.

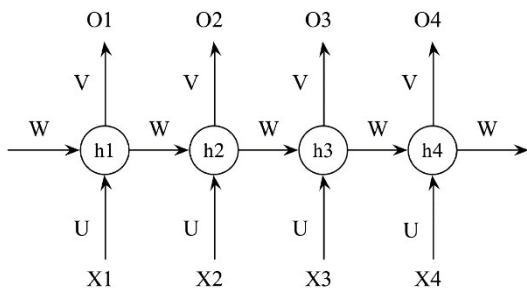

Figure 1: An unrolled RNN

The formulations in an RNN which govern the calculations are as follows.

Let  $x_t$  be the input at time step  $t$ . For example,  $x_i$  can be a one-hot vector or word embeddings corresponding to the  $i^{\text{th}}$  word of a sentence.

$h_t$  be the hidden state and the “memory” of the network at time step  $t$ .  $h_t$  is calculated according to the previous hidden state and the input at the current step:

$$h_t = (Ux_t + Wh_{t-1})$$

Here, to calculate the first hidden state,  $h_0$  is usually initialized to a vector zero.

- $o_t$  will be the output at each time step  $t$ . For sentiment classification of short texts, it would be a vector of probabilities across all the sentiment categories.  $o_t$  will be calculated as follows:

$$o_t = \text{softmax}(Vh_t)$$

**B. Long Short Term Memory (LSTM)** LSTM is a special kind of RNN. They are capable of learning long-term dependencies (Understanding LSTM Networks -- colah’s blog, no date). LSTM is initially introduced by Hochreiter & Schmidhuber in 1997, and several men were mastered and popularized in subsequent research. They work immensely well on a wide range of problems and are now broadly used.

All recurrent neural networks take the shape of a series of repeating neural network modules. In both standards, RNN’s and LSTM’s they have a chain-like structure, but the repeating module in LSTM has a different structure compared to the RNN’s simple structure. That is, it has 4 layers that interact in a typical way instead of having a single neural network layer.

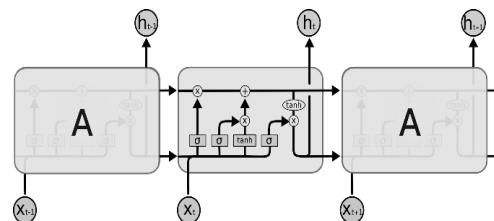

Figure 2: The repeating module of an LSTM

The learning phase depends on the magnitude of weights in the transition matrix. If the weights of the matrix are small this means that the gradients are called vanishing. But, if the transition matrix weights are large, it makes learning to get diverged. So, a typical LSTM model has a memory cell where it solves the issues of vanishing and diverging gradients.

### C. Flask web framework

Flask is a Python web framework designed with a small core and in an easy-to-extend philosophy (Flask, no date). As the equivalent Flask web program becomes more transparent in common cases, Flask becomes considered more of a Pythonic software platform than other approaches. By default, Flask doesn't have a database abstraction layer, type validation, or anything else because there are already specific libraries that would handle them. Conversely, Flask allows plugins to apply to the program certain features as if it were implemented in Flask itself. This web framework work is used to connect the web application with the python coded program in this project as it will be the linker of the web UI.

#### D. Nvidia CUDA toolkit

CUDA (Compute Unified Device Architecture) is developed by Nvidia for a parallel computing platform and it is an application programming interface (API) model where it allows software developers to use CUDA-enabled graphics processing unit (GPU) for the general-purpose data processing ('CUDA', 2020). The CUDA interface is a software framework that provides direct access to the virtual instruction set of the GPU and parallel computing elements for computer kernel execution. Some of the advantages of using a CUDA enabled GPU for the training process are, it can scatter read the code from arbitrary addresses in memory, enables faster downloads and readbacks to and from the GPU and exposes a fast shared memory region that can be shared among threads.

#### Implementation

This system has been implemented in three main stages; named the creation of Sinhala lyrics Corpora and the Extraction & scraping stage, the Model training stage, and the Web serving stage. In this section, this paper will be discussing the implementation of the system based on these three stages.

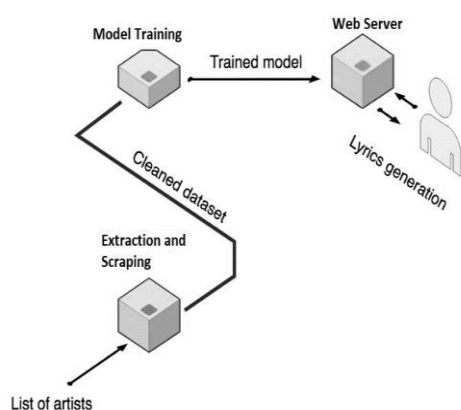

Figure 3: The big picture

#### A. Extraction & scraping stage

First, the creation of Sinhala lyrics corpora is done by collecting various song lyrics from different sources and categorizing them

according to the lyricist and also another full dataset with all the lyrics combining without any specification of the lyricist type for the sake of different testing and evaluations. Since there is no such Sinhala song lyrics dataset/corpus available to be directly downloaded on the internet, creating a large set of such datasets is also a challenging task. Then the collected lyrics are scraped manually to eliminate the use of repetitions, signs, ellipses, and explanation abbreviations such as chorus, verse, etc.

#### B. Model training stage

Then the scraped cleaned dataset of lyrics are fed into the system for the creation of the training

RNN model which will be the core behind generating new lyrics. The models are trained with different parameters and temperatures to obtain a various set of outputs to compare and get a detailed idea about the accuracy and success of the generating output. Many neural network implementations are available online currently. But it is intended to choose one and fine-tuned implementation to fit the need: textgenrnn - a python project for text-generation using neural network. For this model training process, the CUDA enabled GPU acceleration has been used to obtain a faster training time compared to ordinary CPU training.

#### C. Web serving stage

After training the model the testing is done and the generated model is served in the localhost. A separate web UI front-end has been developed to interact with the user for the ease of using the system, where it will allow a user to enter just a few keywords according to his/her preference then hit a button to generate lyrics and display the generated lyrics in the same webpage. To serve the application, the flask python framework is used, so it will be easy to fit the

system into a web server to provide a user-friendly UI.

**Results and Evaluation**

Three basic models were created initially with different parameters and epochs and the same input of two keywords was given to each model to test the results of the generated lyrics output for the comparison. Two outputs from the same keyword were generated for this task.

Input keywords: “ඔබට මම” A. Model-1 results

Corpus size: 30 songs

No.of epochs: 10

*Table 2: Model-1 results*

Output 1	Output 2
ඔබට මම ආදරය මට නිමල දැවෙන යටින් මා මා මන් බැඳී රංජනා	ඔබට මම ආදර හද කී ටොලී තෙ තෙ මා තනිටෙම අහමවබන් දෙව ටේ

B. Model-2 results

Corpus size: 78 songs

No.of epochs: 25

*Table 3: Model-2 results*

Output 1	Output 2
ඔබට මම ආදරය පෑ දෙව ටේ ඔබ උන්ටු තැන හවේ තාමන් හරිම උණසුමයි	ඔබට මම ආදරය දෑ ම ඇයිපිය වනාවහළනො දුර ඇත සුලවේද පාවී හමන්වන්

C. Model-3 results

Corpus size: 78 songs

No.of epochs: 50

*Table 4: Model-3 results*

Output 1	Output 2
ඔබට මම එහා දුක් ජීවිවන් ටේවන්හවේ හැටුවන් හීනාවහනො ඔබ මා හඬනා දෙව ටේ ඔබ මා යළි හමුටෙන්නේ ටේ ටේවන ල ටේ න තෙ නෑ	ඔබට මම එහා මද අදුවේ ටේවන පුරා මල් පැළදි ලීවේ වහාද හීන ටුවේ කරමි තෙ වලාටෙකින් ලබන්නද

These are some outputs generated from the system and we can evidently see that with

the increment of the number of epochs and the number of song lyrics that are trained in every three models, the generated output has a clear growth in terms of accuracy and meaning. Model 3 which is built with 78 songs and trained with 50 epochs has produced far better results compared to model 1 where it has only 30 songs and trained with 10 epochs. Furthermore, we can see that with the increase in the number of lyrics trained, and the training number of epochs, the generating results will be more accurate and semantically meaningful.

The final system will be having a model with ten times the number of song lyrics currently it has with it and they will be trained with more epochs into different temperatures to generate better Sinhala lyrics. And a human evaluation will be conducted in the future to assess how well the generated lines are in terms of the lyrics is either an existing one, written by a lyricist or a generated one from the system.

**Conclusion**

Today, nearly every industry in the world uses somewhat of software to perform a specific task. The purpose of this research work was therefore to incorporate an innovative method that could aid the songwriters in their task. This system uses lyrics corpus with a deep RNN model to train them and, the user can enter his desire keywords to the system to generate new lines of Sinhala lyrics. The generated initial results were promising than expected and they were grammatically meaningful most of the time. By increasing the number of lyrics count in the corpus and performing many epochs in different temperatures while training will be resulting to improve the quality of the generated lyrics. In future work, the system will be developed by using different models categorized by each lyricist, so the user will be able to select his/her desired lyricist and generate new lines of lyrics according to the selected lyricist style.

And also, to explore other approaches to determine whether there are any better solutions to generate lyrics except RNN models.

### Future Works

As for the future works, it is supposed to develop the models with more song lyrics to increase the size of data in the corpora to develop even more rich models. Also, we can perform a data augmentation process to increase the size of the corpora so it will be more of an efficient and time-saving way rather than increasing the entire corpora size manually. Then it is supposed to fine-tune the models by changing the temperatures in the core system. Also, we can try out the results by changing the architecture we currently initialized and then check the results to find whether we can implement a better way compared to the current architecture. Another improvement of the system will be to categorize the generating lyrics according to the type of the lyricist. This can be done by creating different models for each lyricist and train them to generate according to that lyricist type. Finally, it is supposed to create a complete web interface for the user to interact with the system in a pleasant and userfriendly way.

### References

- 'CUDA' (2020) Wikipedia. Available at: <https://en.wikipedia.org/w/index.php?title=CUDA&oldid=961783159> (Accessed: 9 July 2020).
- Feng, X. et al. (2018) 'Topic-to-Essay Generation with Neural Networks', in Proceedings of the Twenty-Seventh International Joint Conference on Artificial Intelligence. Twenty-Seventh International Joint Conference on Artificial Intelligence {IJCAI18}, Stockholm, Sweden: International Joint Conferences on Artificial Intelligence Organization, pp. 4078–4084. doi: 10.24963/ijcai.2018/567.
- Flask (2017). Available at: <https://www.fullstackpython.com/flask.html> (Accessed: 9 July 2020).
- Huang, R. (2016) 'Convolutional Neural Networks and WordEmbedded for Text Classifier', p. 90.
- Liu, S. et al. (2014) 'A Recursive Recurrent Neural Network for Statistical Machine Translation', p. 10.
- Logan, B., Kositsky, A. and Moreno, P. (2004) 'Semantic analysis of song lyrics', in 2004 IEEE International Conference on Multimedia and Expo (ICME) (IEEE Cat. No.04TH8763). 2004 IEEE International Conference on Multimedia and Expo (ICME), Taipei, Taiwan: IEEE, pp. 827–830. doi: 10.1109/ICME.2004.1394328.
- Mahedero, J. P. G. et al. (2005) 'Natural language processing of lyrics', in Proceedings of the 13th annual ACM international conference on Multimedia - MULTIMEDIA '05. the 13th annual ACM international conference, Hilton, Singapore: ACM Press, p. 475. doi: 10.1145/1101149.1101255.
- Maruli Manurung, H., Graeme, R. and Thompson, H. (2000) 'Towards A Computational Model of Poetry Generation', p. 11.
- Mayer, R., Neumayer, R. and Rauber, A. (2008) 'RHYME AND STYLE FEATURES FOR MUSICAL GENRE CLASSIFICATION BY SONG LYRICS', p. 6.
- Nguyen, H. and Brian Sa (2009) 'Rap Lyric Generator', p. 9.
- Oliveira, H. R. G., Cardoso, F. A. and Pereira, F. C. (2007) 'Tra-la-Lyrics: An approach to generate text based on rhythm', p. 9.
- Pudaruth, S., Bhaukaurally, B. F. and Didorally, M. H. A. (2012) 'A Semi-Automated Lyrics Generation Tool for Mauritian Sega', IAES International Journal of Artificial Intelligence (IJ-AI), 1(4), pp. 201–213. doi: 10.11591/ijai.v1i4.801.
- Settles, B. (2010) 'Computational creativity tools for songwriters', p. 9.
- Sutskever, I., Martens, J. and Hinton, G. (2011) 'Generating Text with Recurrent Neural Networks', p. 8.
- Taneja, P. and Verma, K. (2017) 'Text Generation using different Recurrent Neural Networks'.



Understanding LSTM Networks -- colah's blog (2015). Available at: <https://colah.github.io/posts/2015-08Understanding-LSTMs/> (Accessed: 3 July 2020).

Vechtomova, O. et al. (2018) 'Generating lyrics with variational autoencoder and multi-modal artist embeddings', p. 5.

Zheng, H.-T. et al. (2018) 'Automatic Generation of News Comments Based on Gated Attention Neural Networks', IEEE Access, 6, pp. 702–710. doi: 10.1109/ACCESS.2017.2774839.

### **Acknowledgement**

I would like to express my highest gratitude towards my supervisor Ms. Kalani Sriya Ilmini for the help in writing this paper. Thank you for your guidance and the support given throughout this project and I am eternally grateful once again.

### **Author Biographies**



Sheng Kao is an undergraduate student in the Computer Science department, faculty of computing at General Sir John Kotelawala Defence

University, Ratmalana, Sri Lanka. And he will be graduating in 2021 with a BSc in Computer Science. Sheng has a strong interest in the field of Machine learning, Artificial Neural networks, and Computer Music.



Kalani Ilmini is a lecturer at General Sir John Kotelawala Defence University, Ratmalana, Sri Lanka. Her research interests include

Deep Learning, Artificial Neural Networks, Data mining and Affective Computing.

## A software based solution to estimate the angles of incidence of AK bullets using bullet hole features on 1mm sheet metal

Major Bandula Nishshanka<sup>#1</sup>, Dr Chris Shepherd<sup>2</sup> and Major Randika Ariyaratna<sup>3</sup>

<sup>1,3</sup>Centre for Research and Development (CRD) – Ministry of Defence, Sri Lanka

<sup>2</sup>School of Physical Sciences, University of Kent, UK

<sup>#</sup>bmsnishshanka@yahoo.com

**Abstract:** Bullet holes and their characteristics are considered important evidence in shooting incidents and can play a major role in the determination of a fired bullet's trajectory. This research aimed to design a software-based tool for bullet trajectory determination in shooting investigations. The development of the tool was based on the analysis of data from previous empirical test results of two research papers from the authors relating to the numerical relationship of AK bullet hole features and the angles of incidence when AK bullets (7.62mm x 39mm) perforate and ricochet off 1mm zinc coated automotive sheet metal. The proposed solution suggests an alternative method to existing bullet trajectory estimation methods used in shooting investigations through a novel software-based approach.

**Keywords:** Forensic Ballistics, Shooting Incident Reconstructions, Bullet Trajectory Determination

### Introduction

Bullet holes and their characteristics are considered an important source of evidence from shooting incidents and can potentially play a major role in the determination of fired bullet's trajectories to estimate the approximate location of the shooter (Bureau of Criminal Apprehension, 2009). There are currently a few methods that are used to determine the trajectory of fired bullets from bullet holes and the trajectory rod method (Haag & Haag, 2006) can be identified as the most commonly used method. This method ideally uses two consecutive bullet holes caused by a single bullet in a primary and

secondary target surface to determine the trajectory of fired bullet and the approximate angle of incidence is identified using a rod to connect the two bullet holes. The laser method (Vecellio, 2013) and stringing method (Parkinson, 2003) may also assist to indicate angles using lasers and strings respectively between two bullet holes. However, when there is a single bullet hole, it is challenging to identify the angle of incidence for a perforating bullet interacting with any surface. In such occasions the lead-in method and ellipse methods (Mattijssen and Kerjhoff, 2009) are used and the approximate angle of the bullet is estimated using the physical characteristics and dimensions of the bullet hole on the target surface. However, each method has its own limitations and the accuracy and the reliability of the estimated angles of incidence are dependent on many factors, most importantly the target surface and the bullet design (Mattijssen and Kerjhoff, 2009). Therefore, alternative methods to accurately identify the angles of incidence for fired bullets interacting with a target surface types have become a contemporary requirement to correctly identify trajectories for accurate incident reconstructions.

Out of the many bullet types and associated target surface types reported in previous shooting incidents, the AK family rifles (Figure 1) and zinc-coated 1mm sheet metal are a common firearm and surface combination in urban shooting incidents worldwide, including in Sri Lanka. With this rifle type being a popular choice of terrorists

and criminals with its availability, all weather use, reliability to name but a few reasons (The Economist, 2014) and the great existence of 1mm sheet metal in urban environments in various forms, such as automotive bodies, partitioning, house walls, roofs, electronic equipment, storage equipment, display and sign boards, air craft wings etc., this combination makes it ideal for simulating an urban environment for bullet trajectory reconstruction studies. This combination of materials is only expected to become more prevalent in the future due to increased use of 1mm sheet metal used in different urban constructions, applications and the continuous popularity of the AK family firearms amongst criminals, already dubbed the “deadliest gun of the earth” (Balke, F 2018 )



Figure 1: An AK-47 Assault rifle with its ammunition (7.62x39mm) Source: Business insider, 2017

This research aimed to design a software-based tool for trajectory determination of fired AK bullets, using the previously observed numerical relationships between AK bullet holes, feature dimensions and angles of incidences for AK bullets. The source of data to produce the software came from author’s previous studies; an AK bullet ricochet study on 1mm sheet metal (Nishshanka, Shepherd and Parnitharan, 2020) and an AK bullet perforation study on 1mm sheet metal (Nishshanka, Shepherd and Ariyaratna, 2020). The tool was initially designed to be a desktop application and it later proved to be possible for development as an Android application which can be installed and used with a mobile phone or smart device.

## Methodology

Reported consistent relationships between the lengths of the ricochet, perforation marks, lengths of the double headed impact mark (Figure 2) and the bullet’s angle of incidence during the two empirical studies (Nishshanka, Shepeherd and Parnitharan, 2020) and (Nishshanka, Shepherd and Ariyaratna, 2020) were utilized to design the software-based tool. The summary of measurements recorded in both the experiments with regard to the average full lengths and average lengths of the first head of the double headed impact mark is summarized in Tables 1 and 2. Data had been collected under similar conditions during both the studies and involved firing 7.62 mm x 39 mm bullets (Ball rounds with a lead and steel core bullet and copper casing) into 1 mm sheet metal surfaces from 3 degree to 90 degree angles. The experimental arrangement that was used for data collection is shown in Figure 3.

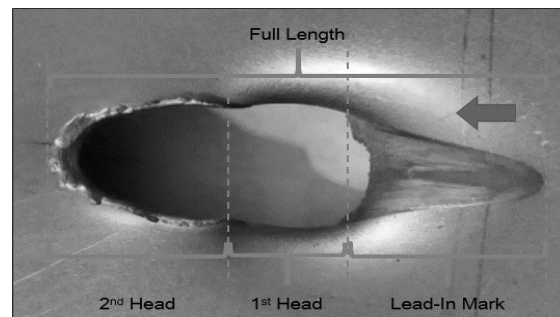

Figure 2: A double headed impact mark and its characteristics. The phenomenon was reported in both the studies as a common occurrence when AK bullets interact with 1mm sheet metal at low angles of incidence.

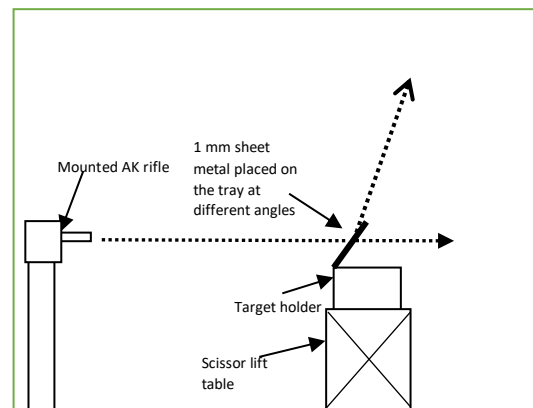

Figure 3: Experimental Arrangement (Nishshanka, Shepherd and Paraneetharan, 2020)

*Table 1: Summary of angles of incidence and the average full lengths of the bullet impact marks created by AK bullets on 1 mm sheet metal.*

Angle of incidence (Degrees)	Average full length of the impact mark (mm)	Reference
90	7.63	Nishshanka, Shepherd and Ariyaratna, 2020 (AK Bullet Perforation Study)
80	7.78	
70	7.96	
60	8.87	
50	9.98	
40	12.23	
30	17.71	
20	27.36	
15	37.96	Nishshanka, Shepherd and Parnitharan, 2020 (AK Bullet Ricochet Study)
13	36.66	
10	42.31	
8	47.84	
5	64.97	
3	94.73	

*Table 2: Summary of angles of incidence and the average length of first head from impact mark related to the double headed impact marks created by AK bullets on 1 mm sheet metal.*

Angle of incidence (Degrees)	Average length of first head from impact mark (mm)	Reference
30	5.01	Nishshanka, Shepherd and Ariyaratna, 2020 (AK Bullet Perforation Study)
20	6.69	
15	8.16	Nishshanka, Shepherd and Parnitharan, 2020 (AK Bullet Ricochet Study)
13	10.35	
10	13.42	
8	17.62	

The full lengths of the bullet hole and the measurement of the first head of a special bullet hole feature, the double headed impact mark, were analyzed and these two variables were identified as having a very consistent relationship with the angles of incidence of the AK bullets. Data was imported to

MATLAB software and a regression analysis was performed. The equations proposed by the analysis were used to design the software-based application. Figures 4 and 5 highlight the relationship identified along with the equation of the best fitted curves.

General model Rat22:  
 $f(x) = (p1*x^2 + p2*x + p3) / (x^2 + q1*x + q2)$   
 Coefficients (with 95% confidence bounds):  
 p1 = -5.995 (-11.12, -0.8724)  
 p2 = 829.5 (522.5, 1137)  
 p3 = -5554 (-7313, -3796)  
 q1 = -1.69 (-7.734, 4.354)  
 q2 = -40.59 (-82.59, 1.403)

Goodness of fit:  
 SSE: 23.71  
 R-square: 0.998  
 Adjusted R-square: 0.9972  
 RMSE: 1.54

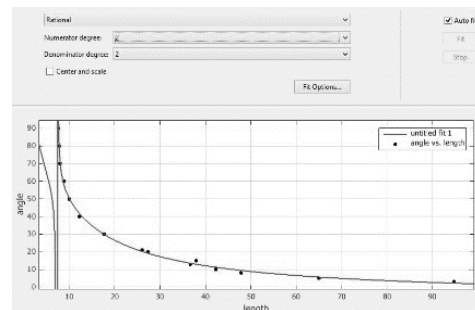

*Figure 4: Relationship identified in MATLAB between the average full lengths of the AK bullet mark and the angles of incidence of AK bullets.*

General model Rat21:  
 $f(x) = (p1*x^2 + p2*x + p3) / (x + q1)$   
 Coefficients (with 95% confidence bounds):  
 p1 = 0.003461 (-1.099, 1.106)  
 p2 = 3.008 (-25.79, 31.81)  
 p3 = 71.11 (-141.4, 283.6)  
 q1 = -2.141 (-5.442, 1.16)

Goodness of fit:  
 SSE: 1.477  
 R-square: 0.9957  
 Adjusted R-square: 0.9914  
 RMSE: 0.7018

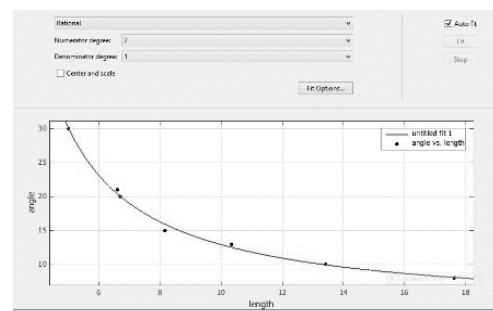

*Figure 5: Relationship identified in MATLAB between the average first head lengths for the bullet holes and the angles of incidence of AK bullets.*

The technologies associated with the development of the software tool are illustrated in Figure 6 and the system diagram is illustrated in Figure 7.

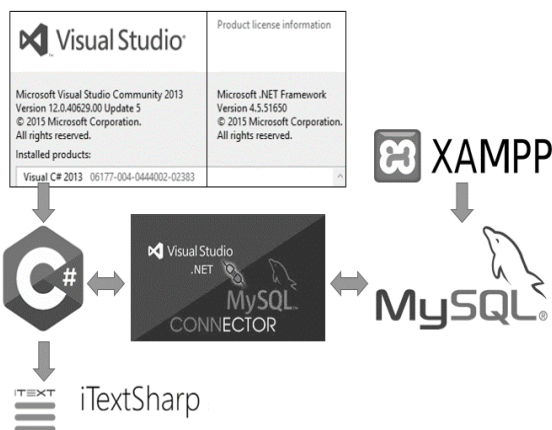

Figure 6: Technologies used to implement the angle of incidence finder desktop application.

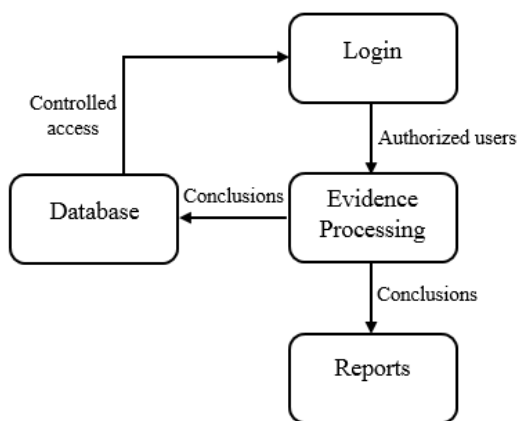

Figure 7: The system diagram for the software tool.

The implementation of the software program was done using the C# programming language which is integrated to the Microsoft Visual Studio development environment. The MySQL relational database management system, which runs on the XAMPP cross-platform web server solution, was used to store user logins. MySQL Connector for .NET handled the data parsing between the C# and MySQL. Logged in users can see the output results generated by the software and outputs can be generated as presentable reports via iTextSharp PDF generating library and stored in the database.

## Results and Discussion

The designed software tool was capable of directly inserting the manually measured full lengths of a bullet impact mark and first head's length of double head impact marks to the system to generate a value for the approximate incoming angle of fired bullets. An example of the designed solution is illustrated in Figures 8 and 9.

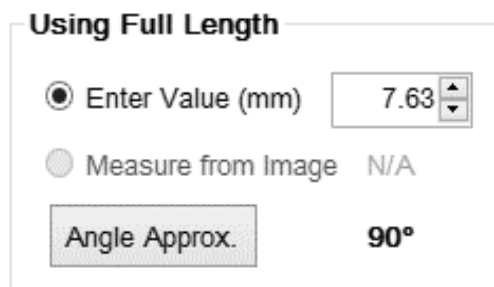

Figure 8: Using mark full length value directly to generate the approximated incidence angle.

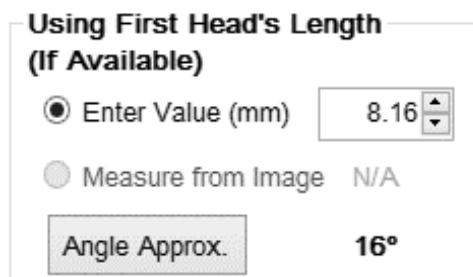

Figure 9: Using first head's length value directly to generate approximated incidence angle.

Alternatively, the tool was designed to use an image of the bullet impact mark as an input to generate the approximate angles of incidence. An investigator who wishes to use the second option needs to take a close picture of the bullet impact mark, placing a crime scene ruler adjacent to the bullet hole. The picture is then imported into the software and two reference points which depict a known distance along the crime scene ruler be marked as reference points A and B using a mouse pointer or a digital pen. This is done to find how many pixels were there to represent the measured length. With reference to that length, the software identifies the actual distances measured in the captured image. This process calibrates

the software. Afterwards, the distance inputs are to be feed in to the system in the same way as two reference points were marked. A system generated message is designed to appear with the relevant instruction in the software to guide the user through the process. Initial software calibration method is illustrated in Figure 10.

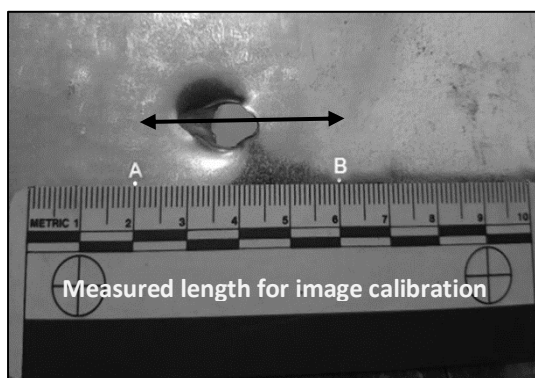

Figure 10: A pictorial illustration of the calibration process.

Thereafter, the system generates results for the full impact length and the first head's length measured on the image. The system also indicates whether the bullet hole is produced as a result of an AK bullet perforation or ricochet off the surface, based on the ricochet and perforation data in Tables 1 and 2. An example case of generating an incidence angle based on the full length measured on a calibrated image is shown in Figure 11.

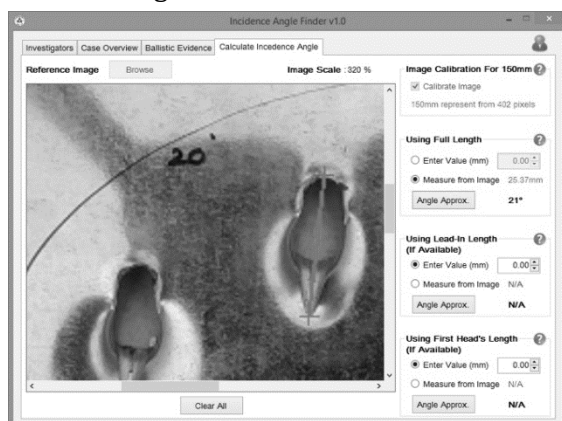

Figure 11: Using full length measurements on calibrated image to generate approximated incidence angle.

The system was developed initially as a desktop application to assess the feasibility of designing a software-based solution and

proved to be viable for upgrading to an Android application for the practical use so that an investigator can install the app on their smart devices and use at a shooting scene to instantly scan an AK bullet hole on 1 mm sheet metal surface. The system also has the possibility of introducing this method for other ammunition and target combinations which are commonly reported in shooting incidents. For this experimental data already available can be used or collated in empirical studies using the same methodology.

The results were tested using a field test in which a different AK rifle (Type 56 MK II) was randomly fired at 1mm sheet metal surfaces in different angles from 90 to 3 degrees. The obtained approximate angles through the new tool were compared with the actual angles of incidence for the bullets. The generation of the approximated angle of incidence achieved up to 95% accuracy when the user directly input the full mark length and the first head's length of the bullet hole while a 92% accuracy rate achieved when the image processing method was employed. It is understood that errors made while marking the reference points for the calibration and when marking the exact edges of the bullet impact mark can affect the outputs, helping explain the reported lower accuracy rate from the image processing option over direct value input. However, as the "accepted margin of error for bullet trajectory determination within the shooting reconstruction community is typically plus or minus 5 degrees, both vertically and horizontally" (Huesky E.E, 2020), the results are viable for use in reconstruction efforts.

## Conclusion

Empirical test result from two previous studies by the authors were used to design a software-based tool to support AK-related shooting incident reconstructions when impacting 1 mm sheet metal target surface. A software solution was designed based on the relationships identified between the lengths

of the bullet holes, the lengths of the first head of the previously reported double headed impact marks and angles of incidence of AK bullets. The initial desktop application proved to be an effective method to quickly provide approximate angles of incidence for AK bullets perforating through or ricocheting off 1mm sheet metal surfaces. Based on the results, it is also expected that an Android-based application compatible with mobile phones or smart devices can now be produced as well. In relation to the direct analysis from photographs, image processing and machine learning may be employed to generate more accurate results invariant of colour, rotation, scaling, skewing of the source image along with a cloud services-based solution are also expected to be incorporated to further upgrade the system for the effective use of this tool by authorised individuals or investigation organisations globally.

This tool has added an alternative method for the analysis of single bullet holes to the currently practised processes (lead in method and ellipse method (Mattijssen and Khoff 2016). Therefore, the solution proposed here could also be used as an alternative method to confirm the findings from existing methods or could be used alone as a reliable method to estimate the approximate angle of incidence for AK bullets fired into 1mm sheet metal surfaces in shooting incidents. The software tool can be further expanded by incorporating empirical test results for other ammunition types and interaction surface combinations and could be made accessible to law enforcement and other investigative end users around the world.

## References

Balke, F (2018). Meet the AK-47 Assault Rifle: The Deadliest. Available at: <https://nationalinterest.org/blog/buzz/meet-ak-47-assault-rifle-deadliest-gun-planet-37042> (Accessed on 23 July 2020)

Bureau of Criminal Apprehension (2019) Shooting Scene Reconstruction. Available at: <https://dps.mn.gov/divisions/bca/bca-divisions/forensic-science/Pages/forensic-programs-crime-scene-ssrecon.aspx>. Accessed; 9 April 2020. Business insider, 2017

The Economist (2014) Why did the AK-47 become so popular? Available at <https://www.economist.com/the-economist-explains/2014/01/08/why-did-the-ak-47-become-so-popular>. Accessed on 5 June 2020

Haag, M. G and Haag, M. C (2006) Shooting Incident Reconstruction. First Ed. Elsevier Inc.

Mattijssen E.J.A.T and Kerkhoff, W (2016) 'Bullet trajectory reconstruction - methods, accuracy and precision', *Forensic Science International*, 262, pp. 204-211 Available at: <https://www.sciencedirect.com/science/article/pii/S0379073816301268> (Accessed on 21 April 2020)

Mattijssen E.J.A.T, Kerkhoff, W, Besterbreurtje, M.E (2018) 'Bullet Trajectory After Impact on Laminated Particle Boards', *Journal of Forensic Sciences*, 63 (5).

Nishshanka, B, Shepherd, C and Paraneetharan, P (2020) Forensic based empirical study on ricochet behaviour of Kalashnikov bullets (7.62 mm × 39 mm) on 1 mm sheet metal. *Forensic Science International*. Vol 312.

Nishshanka, B Shepeherd, C and Ariyaratna, R (2020) Unpublished Research work submitted to *Forensic Science International*.

Parkinson, G.A (2003) 'Stringing a Crime Scene to Determine Trajectories', *Journal of Forensic Identification*, 54 (3) Available at: <https://studylib.net/doc/7835301/stringing-a-crime-scene-to-determine-trajectories> (Accessed on 13 July 2020).

Vecellio, M (2013) 'Lase visualization of bullet paths', *Evidence Technology Magazine*, 54 (3) Available at: <http://www.nxtbook.com/nxtbooks/evidencetechnology/20130708/index.php?startid=14#/16> (Accessed on 13 July 2020).

## Acknowledgment

A software based solution to estimate the angles of incidence of AK bullets using bullet

hole features on 1mm sheet metal is a research project carried out at the Centre for Research and Development, Ministry of Defence, Sri Lanka.

### Author Biographies



Major Bandula Nishshanka. A forensic ballistics and firearms specialist at the Centre for Research and Development- MOD, Sri Lanka. Followed a Masters Degree on Forensic Ballistics at Cranfield

University of the UK and currently a reading for a PhD on Forensic Ballistics at the University of Kelaniya.



Dr Chris Shepherd. A ballistics expert and senior lecturer in forensic science based in the School of Physical Sciences at the University of Kent in the United

Kingdom. Chris previously completed his undergraduate BSc(Hons) in Biochemistry at the Bristol University before completing his MSc in Forensic Engineering and PhD in Shock Physics and Wound Ballistics at Cranfield University.



Major Randika Ariyaratna. A Graduate of University of Colombo School of Computing from the field of Computer Science. Currently attached to the Explosive,

Armament, Ammunition and Ballistic Wing-CRD.



## Disease Identification in Leafy Vegetables Using Transfer Learning

JAA Hansika and WMKS Illmini

*Faculty of Computing, General Sir John Kotelawala Defence University, Sri Lanka*

<sup>1</sup>achinihansika.j@gmail.com, <sup>2</sup>kalaniilmini@kdu.ac.lk

**Abstract:** Plants are the major source which gives foods for human to survive. In developing countries like Sri Lanka agriculture plays a major role in the economic success of people live there and as well as for the whole country's success. In such a situation diseases cause huge losses to farmers. The key concept of maintaining quality and quantity of crops is to detect diseases in earlier stages at the correct time and to take preventive actions against the disease. Usually, farmers recognize diseases through naked eye observation. So, it may not be the right caption and it tends to spread wrong pesticides and overdoses of pesticides. Hiring expertise in this area is highly costing and not possible to find that many experts. Here include many techniques used to identify diseases in various types of plants. But those papers do not address the area of Sri Lankan leafy vegetable disease identification. This research work proposed a system with a learning approach for disease identification procedure named transfer learning and fine-tuning, partially tested, and obtain better results. InceptionV3 and VGG16 are the two pre-trained models use to retrain the model. InceptionV3 gain 0.95 training accuracy and 0.79 validation accuracy. VGG16 gain 0.91 training accuracy and 0.86 validation accuracy. At the initial stage the tested system has capable of recognizing brown spot disease at 0.43 and 0.48 testing probabilities in Gotukola, and leaf-spot disease at 0.58 and 0.90 testing probabilities in the Mukunuwana plant through VGG16 and InceptionV3 respectively.

**Keywords:** Convolutional Neural Networks, Transfer Learning, Fine-tuning, crop diseases

### Introduction

Economic success gain through agriculture highly affects the country's success and for the existence of living beings. Agriculture is the main source that supplies food for us. Plant disease causes huge loss to crops by changing the plant's shape, color, and size. Due to the weather changes from time to time, fertilizer in the soil, bacteria, virus, pests tend to cause plant diseases. For example at the end of 2018, Fall Army worm (FAW) which known as Sena Dalambuwa ("Protecting crops from invasive species | Sunday Observer," 2019) widely spread throughout the Sri-Lanka. It firstly infects corn yields and loss of 25% cause from each yield due to the damages of the FAW. Then worms infect for paddy fields. Recently yellow-spotted grasshoppers ("In Sri Lanka, crop-destroying insects follow the COVID-19 pandemic," 2020) hugely spread with the climate at that time throughout Sri Lanka. Those grasshoppers cause damage mainly to coconut plantations. These types of infections make hesitate in those days by rapidly spreading throughout the country and there was no method to control it. If unable to control disease spreadness finally it impact on food security. "25%-30% losses in agricultural products due to diseases, pest and weeds". Diseases make whole crop kill and farmers should regrow them again. This financially affect for farmers and the country. So, to maintain the above state real time disease identification should done in early

stages. If not, expenditure cost increased, and income cost gets decreased. Then there may not any profit remain for the farmer. To maintain the quantity and quality of the crops it should detect plant disease properly and put suitable pesticides to control it at the correct time.

Farmers identify diseases by their naked eye. It may not be the right recognition. Then adding the wrong pesticide and using overdosage also tend to minimize the quantity and quality of the plant. Identify disease at the correct time and using pesticides at the right time is the main scenario when maintaining crops. Hiring expertise in this area for identifying diseases is a high cost for small scale farmers and that person should do certain procedures to identify the disease and it takes much time to process those data. Also, people who involve newly to the agricultural field cannot recognize these diseases one from another. Those who are growing leafy vegetables in houses for their use haven't any idea about these diseases and chemicals adding procedure. Then it tends to use inappropriate pesticides and sometimes overdose usage. Using chemicals for disease reduction in leafy vegetables not good for the health of farmers who are working and eating these leafy vegetables.

The model present in this paper able to identify brown-spot disease in Gotukola plants and leaf-spot diseases in Mukunuwanna plants. The system going to develop will also provide eco-friendly solutions for the disease reduction process. Also, able to prevent over usage of chemicals by giving the exact amount of pesticides we should use to overcome those threats. And it is more accurate and faster than manual methods. Farmers who doing their cultivation on a small scale as well as in largerscale this automated system will be a solution to identify disease in early stages

and to take advice to keep their cultivations in a good state.

The rest parts of the paper organize as follows, section 2 describes an overview of existing systems of disease identification procedure of different kinds of plants.

Section 3 highlights the methodology of the system. Overview of diseases identified by the system depicted in section 4. In section 5 depicts the test results of the model. Finally, the conclusion and further works demonstrate in section 6 and section 7.

### Literature Review

This section includes researches done throughout the world by various people to identify diseases of plant varieties using different kinds of technologies. And methodologies followed by them to configure diseases. About how much accurate the system they proposed and how much success they are, Azzeddine Elhassouny and Florentin Smarandache (Elhassouny and Smarandache, 2019) proposed a smart mobile application model to identify ten types of most common tomato leaf diseases using 7176 leaf images. That model developed based on

MobileNet (Howard et al., 2017) convolution neural network model. To get classification of diseases, the model is ended by the average Pooling of pooling layers, fully connected and the Softmax function with 10 classes. It obtained 86.7%, 88.9%, and 90.3% overall accuracies by changing learning rates 0.01, 0.005, and 0.001 respectively. Xiaoxiao Sun et al (SUN et al., 2018) proposed a system used convolution neural network (CNN) for disease detection of tea leaves 15 063 images with 6 types of infected leave types and damaged leaves. Image enhancement is done by rotating, flipping, and adding noises to the images. After that, the total number of images obtained was 25 186. 93.75% of accuracy gained from CNN algorithm at 0.00007 learning rate. Then compare the obtained

result using Support Vector Machine (SVM) and Back Propagation (BP) neural network to enhance CNN. Those gained 89.36% and 87.66% accuracies respectively. Omkar Kulkarni(Kulkarni, 2018) used health and infected crop leaves images of five types of crop species to use to retrain CNN MobileNet(Howard et al., 2017) and InceptionV3(Szegedy et al., 2015a) models with 5277 images to detect three types of crop diseases from each class. Images gathered from the public ImageNet(Deng et al., n.d.) data set. In crop disease detection, 99.04% gain by MobileNet(Howard et al., 2017) and 99.54% by Inception V3(Szegedy et al., 2015a) model. Boikobo Tlhobogang and Muhammad Wannous

(Tlhobogang and Wannous, 2018)proposed an android based disease detection system using transfer learning models GoogleNet(Szegedy et al., 2015b) and Inception V3(Szegedy et al., 2015a) models. Used 4306 images of Setsewana herb plants from the PlantVillage(Hughes and Salathe, 2016) dataset to train the models. Sharada Prasanna Mohanty et, al(Mohanty et al., 2016) used a public dataset of 54 306 images with healthy and infected leaves and train those using the deep convolution neural network "Caffe"(Jia et al., 2014) to distinguish 14 types of crop species and 26 diseases. The accuracy obtained was 99.35% and 85.53% from GoogleNet(Szegedy et al., 2015b) and AlexNet(Krizhevsky et al., 2012) respectively. The same Caffee(Jia et al., 2014) framework used by Srdjan Sladojevic et, al(Sladojevic et al., 2016) distinguishes 13 variety of plant diseases.

Neethu K. S and P. Vijay Ganesh. (Ganesh, 2017) This proposed system uses to identify leaf disease of lemon, mango and gives fertilizers to control the diseases. Diseases diagnosis using Artificial Neural Networks (ANN). Namita M. Butale and Dattatraya V. Kodavade(Butale and Kodavade, 2019) proposed a disease detection system that

used five different species of plant leaves to detect eight disease types. 63% accuracy obtained by the SVM classifier at last SVM output the infected disease name and the solution to overcome from those diseases.

Varsha P. Gaikwad and Vijaya Musande(Gaikwad and Musande, 2017) proposed a system to identify diseases in the wheat plant. Two classifiers were used in this proposed system. One is a neural network that focuses on color, shape, and texture features. It gave 80.21% of accuracy. The other one is the support vector machine used based on the texture and shape feature of the image. SVM gave 89.23% accuracy.

Chaitali G. Dhaware and K.H. Wanjale(Dhaware and Wanjale, 2017)proposed a system used SVM classifier extract color, texture, and co-relation features and classify whether images of leaves are healthy or infected.

Above research paper publishers address different kinds of disease identification in different plant varieties. There is no such paper for disease classification in leafy vegetables.

## Methodology

This section briefly describes the procedures followed to develop a model for disease identification procedure.

### A. Image Acquisition

Samsung J7nxt and Huawei y7 smartphones are used to grab images of healthy and infected leafy vegetables. Leafy vegetables hugely growing in the Gampaha district and the climate of the environment is mostly similar to the weather condition of other areas in Sri Lanka. I preferred KalEliya and Pallewela area for picture gathering procedure and some pictures are gathered around my home.

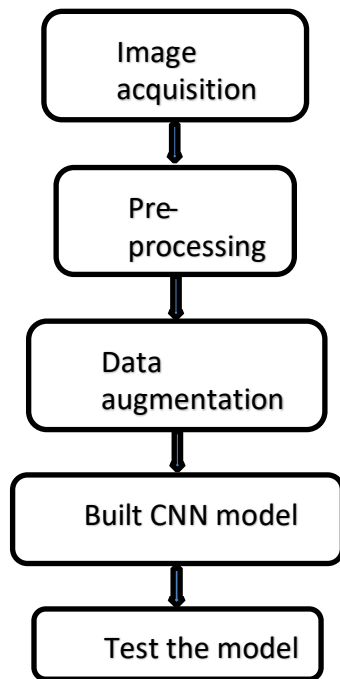

Figure 1: Methodology of the system

#### B. Image Pre-processing

Go through the collected images to select the ones better in quality and remove unwanted images. Then those good quality images separate into folders by going through each by each according to their disease type and leafy type. Images divide into two sets in 24:1 ratio one for training and another for validating and testing. And rename them according to the numbering procedure applied as in pretrained models.

#### C. Data Augmentation

Data augmentation techniques apply to enhance the number of images use to train the model by applying position augmentation horizontal flipping and rotation. Those techniques are used to prevent overfitting and to generate models better.

#### D. CNN Model Build

Retrained the model applying transfer learning and finetuning approaches. InceptionV3(Szegedy et al., 2015a) and VGG16(Simonyan and Zisserman, 2015) are the pretrained models used in here. It's easier to retrain a model than building it

from scratch. Model building from scratch is time-consuming and required more data. Segmentation, feature extraction, classification, and prediction are done by CNN itself. In segmentation infected areas are captured from the image. And from that segmented part features are extract and images are classified according to the similarities in extracted features. Layers of the pre-trained model act as feature extractors. The classification layer, the last layer adds when transfer learning. Finetune by freezing the bottom layers and retrain the remaining top layers of the model. Model train using Stochastic Gradient Descent(SGD) optimizer with 0.001 learning rate, 0.9 momentum and 3 epoches.

#### E. Test the model

Test the developed model using already separated testing data separately for each class. By inputting one image at a time test the model whether predict correctly or not.

### Overview of Leafy Vegetable Diseases

Major disease types cause for leafy vegetables used to train disease identification model as follows,

#### A. Symptoms of brown-spot disease on Gotukola leaves



Figure 2: brown-spot in gotukola

This disease occurs due to Cercospora fungus variety, Purple color rounded spots can be seen in the leaves. At the end leaves turn into yellowish and leaves get to die.

## B. Symptoms of leaf-spot disease on Mukunuwanna leaves



Figure 3: leaf-spot in Mukunuwanna

This disease occurs due to *Cercospora* fungus variety, reddish-brown color spots can be seen in the leaves and spread throughout the leaf and turn it into brownish and dropdown. Mostly can be seen on the matured leaves.

### Results and Discussion

The trained model test for three classes healthy Gotukola, the brown spot in Gotukola, and leafspot in Kankun plants. After training the inceptionV3 model it gains 0.95 training accuracy and 0.79 validation accuracy. VGG16 gain 0.91 training accuracy and 0.86 validation accuracy.

#### A. Prediction results of VGG16 model

Firstly, test the model using an image of brown-spot disease in Gotukola. After inputting an image into the model, it outputs the prediction graph fig.5 and resized image to the target size of 299 x 299 as fig.4.

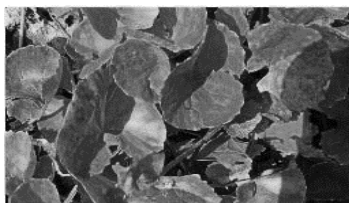

Figure 4: brown-spot in gotukola

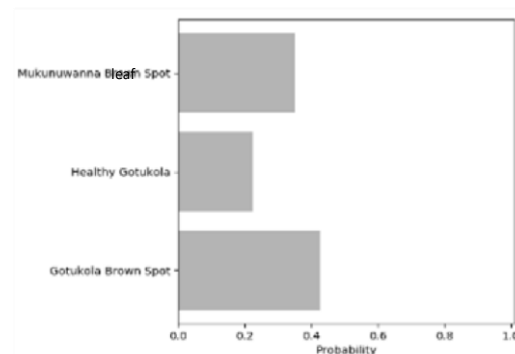

Figure 5: prediction graph

Then test the model using an image of leaf-spot disease in Mukunuwanna. Obtained outputs as the above-tested image depicted using below fig.6 and fig.7



Figure 6: leafspot in Mukunwanna

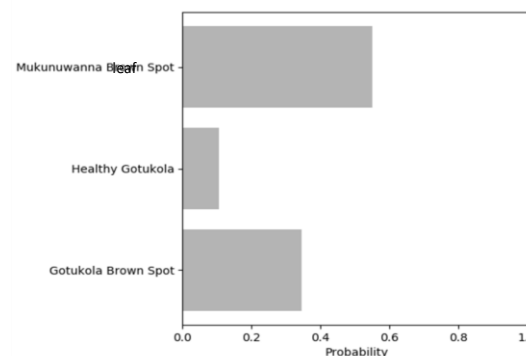

Figure 7: prediction graph

#### B. Prediction results of INCEPTIONV3 model

Firstly, test the model using an image of brown-spot disease in Gotukola. After inputting the image into the model, it outputs prediction graph fig.9 and resized image to the target size of 299 x 299 as fig.8.

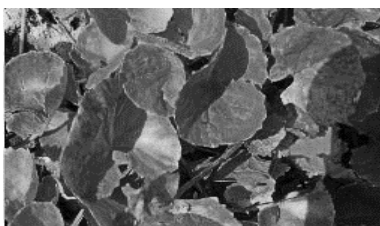

Figure 8: brown-spot in gotukola

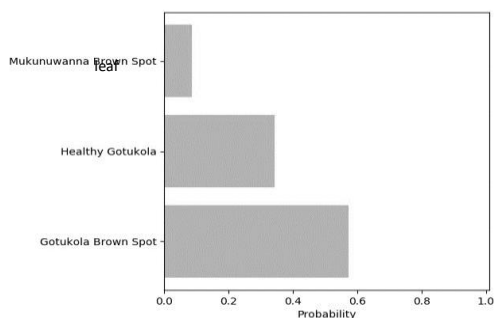

Figure 9: prediction graph

Then test the model using an image of leaf-spot disease in Mukunuwanna. Obtained outputs as the above-tested images depicted using below fig.10 and fig.11.



Figure 10: leafspot in mukunuwanna

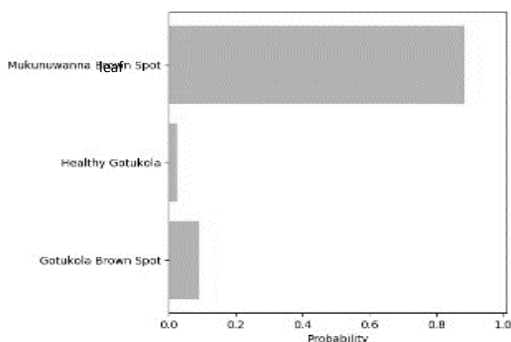

Figure 11: prediction graph

Based on the prediction graph's results in both VGG16 and InceptionV3, better predictive results gained through the inceptionV3 model.

This system further trained for other leafy types Kankun and leafy disease varieties brown spot in Kankun, leaf folding

caterpillars in Mukunuwanna, sap-sucking bug infection in Gotukola and for pest infections. Training and testing results obtained for some of these disease types not accurate much as the above results gained model. Currently, I figuring out reasons for this inaccurate results.

### Conclusion

To increase the productivity of leafy vegetables it is a must to identify diseases at the right time and take preventive actions against diseases. Hence the above-proposed method is accurate to detect diseases at early stages. In terms of testing and training accuracies, InceptionV3 performs better than the VGG16. Also after train the model for other disease types of leafy varieties, after testing for some images it doesn't predict correctly what disease is. Model should make as they predict accurately.

### Further Works

We are going to develop further this model for other leafy vegetable types Kankun, Niwithi, etc, and for other disease types sap-sucking bug infection, leaf folding caterpillar, and other pest infections by enhancing dataset to get better predictive results. Decided to illustrate this model to the farmers by an android mobile application to view the disease and pesticides or natural methods that should follow to overcome form diseases.

### References

Butale, N.M., Kodavade, D.V., (2019). Detection of Plant Leaf Diseases using Image Processing and Soft-Computing Techniques 06, 4.

Deng, J., Dong, W., Socher, R., Li, L.-J., Li, K., Fei-Fei, L., n.d. ImageNet: A Large-Scale Hierarchical Image Database 8.

Dhaware, C.G., Wanjale, K.H., (2017). A modern approach for plant leaf disease classification which depends on leaf image processing, in: 2017 International Conference on Computer Communication and Informatics (ICCCI). Presented at the 2017 International Conference on Computer Communication

and Informatics (ICCCI), pp. 1–4.  
<<https://doi.org/10.1109/ICCCI.2017.8117733>>

Elhassouny, A., Smarandache, F., (2019). Smart mobile application to recognize tomato leaf diseases using Convolutional Neural Networks, in: 2019 International Conference of Computer Science and Renewable Energies (ICCSRE). Presented at the 2019 International Conference of Computer Science and Renewable Energies (ICCSRE), pp. 1–4.  
<<https://doi.org/10.1109/ICCSRE.2019.8807737>>

Gaikwad, V.P., Musande, V., (2017). Wheat disease detection using image processing, in: 2017 1st International Conference on Intelligent Systems and Information Management (ICISIM). Presented at the 2017 1st International Conference on Intelligent Systems and Information Management (ICISIM), pp. 110–112.  
<<https://doi.org/10.1109/ICISIM.2017.8122158>>

Ganesh, P., (2017). Leaf Disease Detection and Selection of Fertilizers using Artificial Neural Network.

Howard, A.G., Zhu, M., Chen, B., Kalenichenko, D., Wang, W., Weyand, T., Andreetto, M., Adam, H., (2017). MobileNets: Efficient Convolutional Neural Networks for Mobile Vision Applications. arXiv:1704.04861 [cs].

Hughes, D.P., Salathe, M., (2016). An open access repository of images on plant health to enable the development of mobile disease diagnostics. arXiv:1511.08060 [cs]. In Sri Lanka, crop-destroying insects follow the COVID-19 pandemic, (2020). Mongabay Environmental News. URL <<https://news.mongabay.com/2020/06/in-sri-lanka-cropdestroying-insects-follow-the-covid-19-pandemic/>> (accessed 7.24.20).

Jia, Y., Shelhamer, E., Donahue, J., Karayev, S., Long, J., Girshick, R., Guadarrama, S., Darrell, T., (2014). Caffe: Convolutional Architecture for Fast Feature Embedding. arXiv:1408.5093 [cs].

Krizhevsky, A., Sutskever, I., Hinton, G.E., (2012). ImageNet Classification with Deep Convolutional Neural Networks, in: Pereira, F., Burges, C.J.C., Bottou, L., Weinberger, K.Q. (Eds.), Advances in Neural Information Processing Systems 25. Curran Associates, Inc., pp. 1097–1105.

Kulkarni, O., 2018. Crop Disease Detection Using Deep Learning, (2018). Fourth International Conference on Computing Communication Control and Automation (ICCUBEA). Presented at the 2018 Fourth International Conference on Computing Communication Control and Automation (ICCUBEA), pp. 1–4.  
<<https://doi.org/10.1109/ICCUBEA.2018.8697390>>

Mohanty, S.P., Hughes, D.P., Salathé, M., (2016). Using deep learning for image-based plant disease detection.

Frontiers in Plant Science 7, 1419.  
<<https://doi.org/10.3389/fpls.2016.01419>>

Protecting crops from invasive species | Sunday Observer, (2019). <<http://www.sundayobserver.lk/2019/01/27/business/protectingcrops-invasive-species>> (accessed 10.21.19).

Simonyan, K., Zisserman, A., 2015. Very Deep Convolutional Networks for Large-Scale Image Recognition. arXiv:1409.1556 [cs].

Sladojevic, S., Arsenovic, M., Anderla, A., Culibrk, D., Stefanovic, D., (2016). Deep Neural Networks Based Recognition of Plant Diseases by Leaf Image Classification. Computational Intelligence and Neuroscience.  
<<https://doi.org/10.1155/2016/3289801>>

SUN, X., MU, S., XU, Y., CAO, Z., SU, T., (2018). Image Recognition of Tea Leaf Diseases Based on Convolutional Neural Network, in: 2018 International Conference on Security, Pattern Analysis, and Cybernetics (SPAC). Presented at the 2018 International Conference on Security, Pattern Analysis, and Cybernetics (SPAC), pp. 304–309.  
<<https://doi.org/10.1109/SPAC46244.2018.8965555>>

Szegedy, C., Vanhoucke, V., Ioffe, S., Shlens, J., Wojna, Z., (2015a). Rethinking the Inception Architecture for Computer Vision. arXiv:1512.00567 [cs].

Szegedy, C., Wei Liu, Yangqing Jia, Sermanet, P., Reed, S., Anguelov, D., Erhan, D., Vanhoucke, V., Rabinovich, A., (2015b). Going deeper with convolutions, in: 2015 IEEE Conference on Computer Vision and Pattern Recognition (CVPR). Presented at the 2015 IEEE Conference on Computer Vision and Pattern Recognition (CVPR), pp. 1–9.  
<<https://doi.org/10.1109/CVPR.2015.7298594>>

Tlhobogang, B., Wannous, M., 2018. Design of plant disease detection system: A transfer learning approach work in progress, in: 2018 IEEE International Conference on Applied System Invention (ICASI). Presented at the 2018 IEEE International Conference on Applied System Invention (ICASI), pp. 158–161. <https://doi.org/10.1109/ICASI.2018.8394556>

### Biography of Authors



Achini Hansika is an undergraduate student who follows the software engineering degree program at Kotelawala defense university, Ratmalana, Sri Lanka.



Kalani Sriya Illmini is a lecture at Kotelawala defense university, Ratmalana, Sri Lanka. Her research interests include deep learning, artificial neural networks, data mining, and affective computing



## Plant Recognition System based on Leaf Images: A Systematic Literature Review

S Donesh#, and UA Piumi Ishanka

*Department of Computing and Information Systems, Faculty of Applied Sciences,  
Sabaragamuwa University of Sri Lanka  
Belihuloya, Sri Lanka*

#sdonesh@std.appsc.sab.ac.lk

**Abstract:** Plant plays a vital role in the environment. Nature has enormous members of plants, identifying them and classifying them is an important task for botanists. They are still finding difficulties in recognizing those plants and it is complex, time-consuming, and due to the use of specific botanical terms, frustrating for the non-experts. There are various ways to recognize a plant, like a flower, root, leaf, fruit, etc. But usually, plants are recognized by leaf and their characteristics like shape, texture, vein structure, color, etc. The availability of relevant technologies, such as digital cameras, new techniques in image processing and pattern recognition thoughts, leads to researching plant leaf recognition systems using image processing techniques rather than using the other parts of the plants. Searching of research papers related to the domain was done in the IEEE computer society digital library, Springer Link, Science Direct, ACM Digital Library, Academia, and other research sites using the search terms like plant leaf identification, plant leaf prediction, plant leaf classification, plant leaf recognition, and image processing techniques. Then started to work on the Systematic Literature Review (SLR) with forty research papers; out of forty, most articles are related and some are not related. Then these articles are filtered and sorted to SLR. Nineteen papers which are published in the past ten years and mostly related to my topic and methodology, were selected to perform SLR. Then the methodologies of the studies were analyzed to identify different

preprocessing and feature extraction methods that researches have employed to identify leaves. Then classification accuracy was compared with related papers and traced the optimal range of the accuracy for leaf recognition, which will be the benching accuracy level for the suggested study.

**Keywords:** plant leaf recognition, image processing techniques, feature extraction, systematic literature review

### Introduction

Plants are the essential natural sources of the earth. Plants play a crucial role in human life by providing shelter and by maintaining a healthy breathable environment. There will be no existence of the earth's ecology without plants. However, recently, several species of plants are at the danger of extinction. To protect plants, a plant database classification is essential. In a manual identification process, botanist uses different plant leaf characteristics as identification keys such as shape, texture, vein structure, color, etc. But this manual process took more time and complex to adapt. To handle such issues of information about plant leaf, the development of a rapid and competent classification techniques has become an active area of research. An image classification process can generally be divided into the following steps, such as Image Acquisition, Preprocessing, Feature Extraction, and Description and Classification. So these techniques can help the plant classification accurately. This paper discusses the existing feature extraction

techniques and classification techniques in the state of the art and proposed a novel method for plant leaf classification.

SLR is a preliminary study since it only focused on articles in IEEE explore, Springer Link, google scholar, Science Direct. Although the main reasons for this limitation come from our financial and time issues, we can easily guarantee the quality of articles in our review by this limitation. SLR focused on related researches done by various researchers. So it's very helpful to continue doing this research because it includes various research paper's methodologies, technologies, limitations, results, and future works. SLR is a useful tool to know such trends. We thus performed SLR on traceability and report the results in this paper. Before performing SLR, we had several biases in traceability researches according to our daily research activities.

### **Systematic Literature Review**

SLR is a useful tool to know trends in the plant leaf recognition system while helping to find the most relevant papers within the research domain. It involves identifying, evaluating, and interpreting available research relevant to a certain research question. In our SLR, we are posing the following research questions;

- RQ1: How can a classification help to increase the accuracy of the plant leaf classification? And what type of classification can be used?
- RQ2: How to recognize plant species using image processing techniques that can help botanists and scientists?
- RQ3: What are the appropriate features for plant species recognition in feature extraction?

To refine the number of studies considered in our SLR, we support our question with a set of inclusion and exclusion criteria.

- Research papers in ACM digital library, IEEE computer society digital library, Springer Link, Science Direct, Academia sites were included.
- Articles published from 2010 to 2019 were included, and other articles were excluded. Note that this research was started at the start of November 2019.
- Plant leaf recognition related software and image processing technics were included, and others were excluded.
- Research papers that methodology deviates from image processing techniques were excluded.
- Different types of research methodologies were included.

### **Search Strategy.**

Article papers were identified from searches of Google scholar, IEEE Explore, Springer Link, ACM digital library, Science Direct, and Semantic Scholar. And we searched keywords such as plant leaf identification, plant leaf recognition, plant leaf classification, and plant leaf prediction.

### **Sources**

According to the tertiary study accomplished previously, the following databases were identified as the most relevant databases which contain studies more appropriate to the research domain. Hence, the search was performed in the following databases.

1. IEEE Xplore (<http://ieeexplore.ieee.org>)
2. Springer Link (<https://link.springer.com>)
3. Science Direct (<https://www.sciencedirect.com>)
4. Academia (<https://www.academia.edu>)
5. Research Gate (<https://www.researchgate.net>)
6. ACM Digital library (<https://dl.acm.org>)

## Limitations

In this section, different kind of limitation of this review study are discussed,

Some of the papers were irrelevant to the topic selected.

Some of the research papers unavailable to download

Difficulty in filtering papers according to the domain.

## Results and Findings

The results are about identifying, analyzing, and comparing research work in the field of plant leaf identification using image processing techniques. A systematic review was conducted driven by research questions and using a well-defined process for data extraction and analysis. The following findings summarize the principal results of this systematic review and provide directions for future research. Following are some conclusions,

1. Most studies were conducted by computer scientists.
2. Most studies used images with a plain background, avoiding segmentation
3. The main research focus on leaf analysis for plant identification
4. The shape is the dominant feature for plant identification
5. Contour based shape description was more popular than the region-based description
6. Multi-feature fusion facilities lead to higher classification accuracy

Figure 1 state about how the SLR is conducted and how the papers are acquire related to our research.

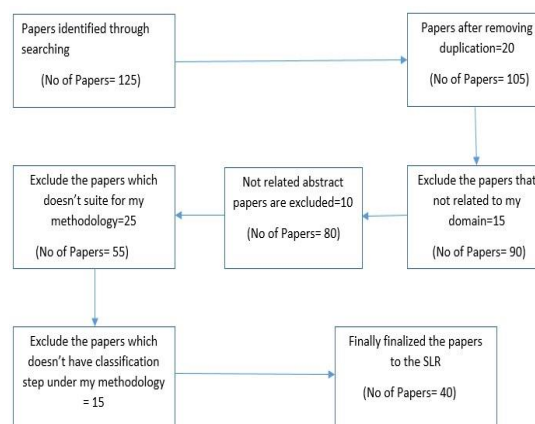

Figure 1: Prisma flow diagram

## Data Collection

32 plant species are taken from the database of <sup>1</sup>Flavia leaves the dataset website, which contains 1909 leaves images. Sample leaves images are stated below in figure 2. They have been categorized according to their scientific name and the common names for easily understanding the image. The images are taken in every possible direction that whatever shape it contains must give more accurate results for that leaf classification.

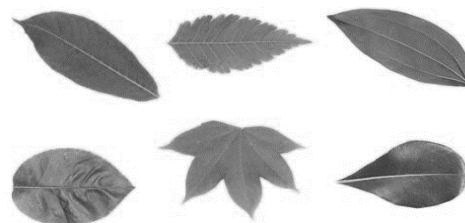

Figure 2: Sample dataset

## Methodology

In this research method, we followed the well-known guideline from conducting my SLR. Figure 3 state about the methodology of the research.

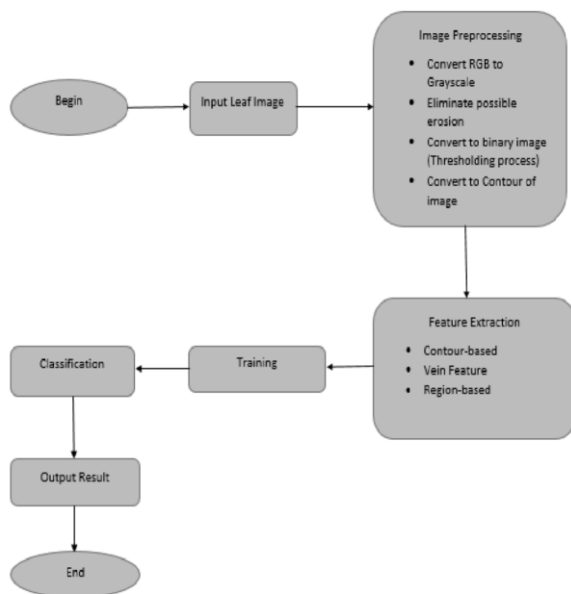

Figure 3: Methodology

In this paper, the research methodology consists of major phases they are image pre-processing, feature extraction, training, and classification.

Image pre-processing consists of convert RGB to grayscale, eliminate possible erosion, convert to a binary image, and convert to the contour of the image.

Feature extraction consists of contour-based, region-based, and vein feature extraction.

Above mentioned phases are implementing using the Jupiter notebook environment in the python.

### Image Preprocessing, Feature Extraction, and Classification Approaches

Commonly most of the research papers describe the same image pre-processing techniques that images are converted RGB to grayscale, eliminate possible erosion, convert to a binary image, image segmentation convert to the contour of the image. The above mention techniques are common approaches in image pre-processing incorporated studies.

Table 1: Feature extraction and classification techniques

Category	Techniques	References	Year
Feature extraction	Basic Geometric Features, Digital Morphological Features	[5]	2012
	Curvelet Transform Descriptors (CTD), Local Binary Pattern, Gray Level Cooccurrence Matrix	[6]	2017
	Shape	[1]	2012
		[4]	2015
		[6]	2013
		[8]	2015
		[9]	2017
	Vein	[7]	2019
		[4]	2015
	Contour	[10]	2010
		[6]	2013
		[5]	2018
		[4]	2015
	Gray Level Cooccurrence Matrix	[7]	2019
[5]		2018	
[3]		2017	
Classifications	Support Vector Machine (SVM)	[9]	2017
		[2]	2012
		[11]	2013
		[19]	2014
		[5]	2018
		[18]	2019
	Artificial Neural Network (ANN)	[8]	2015
		[15]	2015
		[13]	2014
	Probabilistic Neural Network(PNN)	[16]	2007
		[9]	2017
	CNN	[12]	2018
		[14]	2018
	KNN	[11]	2013
[17]		2013	
[9]		2017	

One of the relatively superior and competent classifiers is ANN, especially in terms of its accuracy. This is because ANN is pertinent to resolve non-linear problems like leaf pattern recognition. However, previous research revealed that the leaf with an oblong pattern

could increase the error rate of recognition, possibly due to the uniform structure.

SVM is to define decision boundaries of feature vectors on decision planes, which separates features unanimously. Since the distinction in feature between the images is evident, the images will be classified into their respective class with little to no complication. CNN may involve multiple features extraction, and at the same time, providing detail and quick detection and to robust to the noise. KNN classifies images by comparing the input images to the closest training samples from the feature space. PNN classifier trains the loaded feature vector with a higher speed rate as compared to that of a backpropagation system (See table 1).

### Conclusion

Plant leaf recognition system using image processing techniques have been continuously proposed and evaluated in the literature. By conducting our SLR about software and image processing techniques, we gathered, classified, and analysed such techniques from research questions (RQs) drawn in the Literature Review. The RQs are based on our SLR mentioned in the Introduction. We reviewed forty articles from the IEEE computer society digital library, Springer Link, Science Direct, ACM Digital Library, Academia, and other research sites and then filtered up to nineteen papers to conduct SLR. We got the results and finding, as we mentioned above.

### References

H. Rongxiang, J. Wei, L. Haibin and H. and Deshuang, "Multiscale Distance Matrix for Fast Plant Leaf Recognition," *IEEE TRANSACTIONS ON IMAGE PROCESSING* 2012, vol. 21, pp. 4667-4672, 2012.

C. ArunPriya and T. Balasaravanan, "An Efficient Leaf Recognition Algorithm for Plant Classification Using Support Vector Machine," *International Conference on Pattern*

*Recognition, Informatics and Medical Engineering, March 21-23, 2012*, pp. 428-432, 2012.

A. E. Heba, "Feature Selection for Texture-Based Plant Leaves Classification," *IEEE 2017*, pp. 9196, 2017.

T. Vijayashree and G. and A., "AUTHENTICATION OF LEAF IMAGE USING IMAGE PROCESSING TECHNIQUE," *2006-2015 Asian Research Publishing Network (ARPN)*, vol. 10, pp. 4287-4291, 2015.

Vidyashanakara, M. Naveena, and H. K. G, "Leaf Classification Based on GLCM Texture and SVM," *International Journal on Future Revolution in Computer Science & Communication Engineering*, vol. 4, no. 3, pp. 156-159, 2018.

B. Anant, K. Manpreet and K. and Anupam, "Recognition of plants by Leaf Image using Moment Invariant and Texture Analysis," *International Journal of Innovation and Applied Studie*, vol. 3, pp. 237-248, 2013.

T. Muammer and H. Davut, "Recognition of plant leaves: An approach with hybrid features," *e: www.elsevier.com/locate/amc*, pp. 1-14, 2019.

A. Aimen and F. K. Muhammad, "Automatic classification of plants based on their," *2015 IAgRE*, pp. 66-75, 2015.

X. K. H., J. L. and L. Z. and F., "Classification of Medicinal Plant Leaf Image Based on MultiFeature Extraction," *ISSN 1054-6618, Pattern Recognition and Image Analysis, 2017*, vol. 27, pp. 581-587, 2017.

H. Javed and A. A. M., "Leaf Shape Identification Based Plant Biometrics," *Proceedings of 13th International Conference on Computer and Information Technology (ICCIT 2010)*, pp. 458463, 2010.

C. Ali, G. Oguzhan and B. C. and Ahmet, "A Plant Recognition Approach Using Shape and Color Features in Leaf Images," *Springer-Verlag Berlin Heidelberg 2013*, pp. 1-10, 2013.

B. Ali and F. Karim, "Leaf Classification for Plant Recognition with Deep Transfer Learning," *2018 4th Iranian Conference on Signal Processing and Intelligent Systems (ICSPIS)*, pp. 21-26, 2018.

L. C. Azeil and S. Geoffrey, "Plant Leaf Recognition by Venation and Shape Using Artificial Neural Networks," *IEEE 2014*, pp. 1-4, 2014.

A. P. S., S. K. V. and H. and S., "A study on plant recognition using conventional image processing and deep learning approaches," *Journal of Intelligent & Fuzzy Systems xx (2018)*, pp. 1-8, 2018.

S. Satnam and M. S. B. Dr., "Leaf Identification Using Feature Extraction and Neural Network," *IOSR Journal of Electronics and Communication Engineering (IOSR-JECE)*, vol. 10, no. 5, pp.

134-140, 2015. F. S. B. Stephen Gang Wu1, Y. X. Eric, W. YuXuan, C. Yi-Fan and X. and Qiao-Liang, "A Leaf Recognition Algorithm for Plant

Classification Using Probabilistic Neural Network," *2007 IEEE International Symposium on Signal Processing and Information Technology*, pp. 11-16, 2007.

S. VIJAY, S. ANSHUL and S. SHANU, "AN

AUTOMATIC LEAF RECOGNITION SYSTEM FOR PLANT IDENTIFICATION USING MACHINE VISION TECHNOLOGY," *International Journal of Engineering Science and Technology (IJEST)*, vol. 5, pp. 874-879, 2013.

Z. Xiang, Z. Wanqing, L. Hangzai, C. Long, P. Jinye and F. Jianping, "Plant recognition via leaf shape and margin features," *Springer Science+Business Media, LLC, part of Springer Nature 2019*, pp. 1-27, 2019.

B. Yanikoglu, E. Aptoula, C. Tirkaz, "Automatic plant identification from photographs" Springer-Verlag Berlin Heidelberg 2014, pp. 1369-1383, 2014.

## CNN based image detection system for elephant directions to reduce human-elephant conflict

K.S.P.Premarathna, and R.M.K.T. Rathnayaka

*Department of Computing and Information Systems, Sabaragamuwa University of Sri Lanka, Belihuloya, Sri Lanka  
Department of Physical Sciences and Technology, Sabaragamuwa University of Sri Lanka,  
Belihuloya, Sri Lanka*

ksppremarathna@std.appsc.sab.ac.lk

**Abstract:** Human-Elephant Conflict has been a major issue in the forest border areas, where the human habitat is destroyed by the entry of wild elephants. This conflict depends due to the shared field of humans and elephants. Conflict often occurs over access to water and competition for space and food. Economic losses happen due to agricultural destruction or loss of cattle during predation. The major aim of the study is to minimize the human-elephant conflict in the forest border areas and the conservation of elephants from human activities as well as protect human lives from elephant attacks. Humans use various technical and nontechnical methods to reduce this conflict. As this research is using neural networks and image processing technologies, forest authorities can detect how many elephants are in the nearby forest border areas and distinguish elephants from other animals easily. Then authorities can inform villagers and tourists hence reducing the human-elephant conflict. Convolutional Neural Network (CNN) is playing a major role in elephant detection by supporting efficient image classification. CNN's performance

was evaluated by training and testing the dataset by increasing the number of training and testing images. The dataset includes 5000 images of elephants. The trained model is designed for identifying the elephants. The conclusions drawn from work prove that the achievement percentage is 92% accuracy.

**Keywords:** Human Elephant Conflict, Elephant detection system, Convolutional Neural Networks(CNN)

### Introduction

HEC is a real-world application, which is taken as a case study for this proposed research work. The idea is to provide an early warning indicating elephant detection; therefore it is useful forest officials to chase the pachyderm back into the forest and to help the public save their property and life, which is located near the forest boundary(Eikelboom *et al.*, 2019). Many implementations in the real world include border control networks, environmental monitoring, etc. This paper may have made the first attempt to exploit the benefits of deep learning in forest boundaries for real-world problem detection of elephants(Suganthi, Rajathi and M, 2018). The proposed work is inspired by the automatic identification of species from the camera trap and the identification of elephant images from other photos of specifics according to the literature, cameras played a vital role in elephant detection using different database comparisons utilizing image processing techniques. But the inclusion of false alerts is unavoidable. The objective of the proposed work is to minimize HEC by efficient detection of camera images utilizing the advancement in technical contributions of deep learning. Human elephant conflict affects two broad categories('ele\_survey\_2011.pdf', no date).

One is a problem faced by humans, another one is a problem faced by elephants. The solution for these problems targets to save our life from elephants attack as well as to protect the elephant from human attacks.

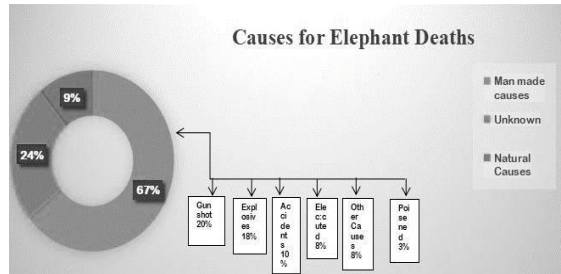

Figure 1. Causes of elephant deaths

Elephants cause more than \$10 million in property damage annually and the farmers kill the elephants in revenge. On average 225 elephants have been killed by peoples annually and elephants have killed about 60-80 people annually, most in their villages and fields (Krötzsch, Siman̄ and Horrocks, 2013).

The boundary between Wasgamuwa National Park and the main water and food source of the elephant is important to elephants but it is also used by villagers living adjacent to the forest reserve (Li *et al.*, 2018). It is not unusual to see children, men, and women walking and biking while elephants are present, always fearful of an elephant attack. And they harass the elephants to scare them away, and unfortunately, this action makes elephants more aggressive than people's fears.

Sri Lanka Conservation Wildlife Society (SCWS) purchases a bus to provide service through the elephant corridor (Sahlol, 2017) The bus will provide secure transport for the villagers while allowing the elephants to use the corridor without being harassed, injured, or chased from their habitat. In general, there are two kinds of losses, human death, and elephant death. Thinking in a short while, the root cause of these losses is caused by both humans and elephants.



Figure 2: Loss of Property

Throughout the forest boundary regions, there are many common methods used to drive away from the elephants once they reach the human settlement regions. They mainly use noise-making techniques including firecrackers, pipe cannons, vehicle horns, shouts, rifle- shots, and banging on things such as drums, tins, etc. Sometimes, they create a fence strung with beehives made out of hollow logs and burn elephant dung along with chili or any other material that will smolder to create a heavy acrid smoke (Ahmed, Jalal and Kim, 2019). However, as time goes on, elephants become accustomed to these approaches and gain the ability to conquer conventional techniques. Therefore a monitoring and detection system is required to send the incoming elephants an alert in advance so that appropriate safety measures can be taken. We are introducing a detection system based on convolutional neural networks.

This detection system helps to find the elephants are nearing the forest border area, thus disseminating warning at the appropriate times and thereby helping in reducing human-animal conflicts in forest areas.

### Methodology

In this paper, the Convolution Neural Network is used as an object detection algorithm. Object detection relates to both machine learning and image processing which is used to detect the instances of the



object. The algorithms for object detection are popularly used in realtime applications.

### A. Convolutional Neural Networks

Convolutional neural network (CNN) is a deep-rooted type, the artificial neural network used for feed-forward to deliver correct computer vision results tasks, for example, classification and identification of images. CNN they're like conventional neural networks, but with deeper strata. This has weights, biases and a nonlinear efficiency Switch on(S, Ramesh and Divya, 2016).

The CNN neurons are organized in a volumetric fashion like height, width, and depth. Illustration figure 3 shows CNN architecture, it consists of completely linked layer, convolutionary layer, pooling layer. Usually, traditional layer and pooling layer are alternated, and each filter's depth increases from left to right, while the output size (height and width) decreases.

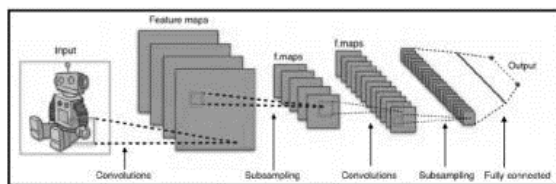

Figure 3. Layered architecture

The input is an image that contains values for pixels. The example is  $[50 \times 50 \times 3]$ , it has three dimensions such as width, height, and depth (RGB channels). The convolutionary layer shall measure the output of the associated neurons output to regional areas (Dharmaratne and Magedaragamage, 2014). The parameters of the layer are composed of a series of learnable filters (or kernels) that translated over the width and height of the input volume extending through its depth, computing the dot product between the input and the filter entries(Wijnhoven and De With, 2010). It provides a 2-dimensional activation map of the filter, and therefore, the network learns filters that occur when a specific type of

feature is detected at some spatial location in the input.

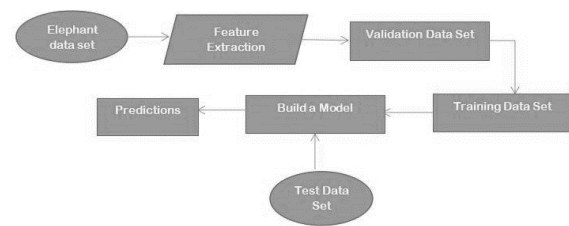

Figure 4. Flowchart of the process

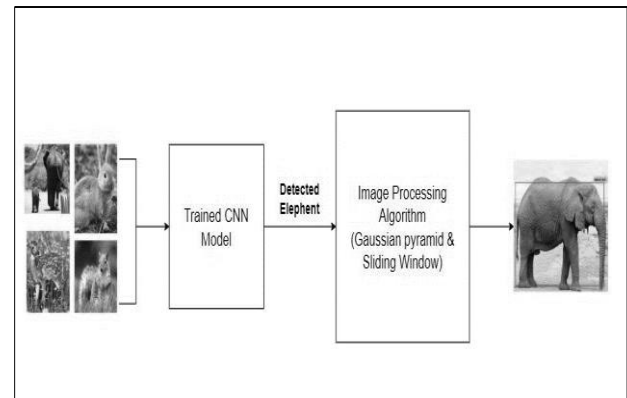

Figure 5. The overall methodology for elephant detection

### B. Create the Model

The image is passed through a series of convolutional, non-linear, pooling and fully connected layers, and then generates the output. A neural network consists of several different layers such as the input layer, hidden layers, and an output layer. They are best used in object detection. The secret layers function as a filter receiving input first, transforming it using a particular template, and sending it to the next layer.

With more convolutionary layers they are modification layer. CNN's have a standard organization: the system includes the multi-layered architecture of feature identifying neurons. Every layer will address all of its previous layer's input combination(Dhanaraj and Kumar Sangaiah, 2018)

### C. Training the model

Now we will train our model. To train, we will use the 'fit()' function on our model with the following parameters: training data (train\_X),

target data (train\_y), validation data, and the number of epochs. For our validation data, we will use the test set and split into X\_test and y\_test. The number of epochs is the number of cycles that data go through the model. The more epochs we run, the model will improve, up to a certain point. After that point, the model will stop improving. For our model, we will set the number of epochs to 50.

Layer (type)	Output Shape	Param #
conv2d_1 (Conv2D)	(None, 798, 598, 32)	896
activation_1 (Activation)	(None, 798, 598, 32)	0
max_pooling2d_1 (MaxPooling2D)	(None, 399, 299, 32)	0
conv2d_2 (Conv2D)	(None, 397, 297, 32)	9248
activation_2 (Activation)	(None, 397, 297, 32)	0
max_pooling2d_2 (MaxPooling2D)	(None, 198, 148, 32)	0
conv2d_3 (Conv2D)	(None, 196, 146, 64)	18496
activation_3 (Activation)	(None, 196, 146, 64)	0
max_pooling2d_3 (MaxPooling2D)	(None, 98, 73, 64)	0
flatten_1 (Flatten)	(None, 457856)	0
dense_1 (Dense)	(None, 64)	29302848
activation_4 (Activation)	(None, 64)	0
dropout_1 (Dropout)	(None, 64)	0
dense_2 (Dense)	(None, 2)	130
activation_5 (Activation)	(None, 2)	0

Figure 6. Output after applying CNN

#### D. Image Processing

Image processing is a process of mutating which converts input picture in digital form, and some more added submit image operations to receive a renovation image or to derive any valuable knowledge from the embedded picture. In this method, the input and output of which is often in the form of photographs involve processes that extract features from images up to the end, including the recognition of individual objects in the image. (Lin *et al.*, 2010)

There are two algorithms used for image processing.

1). Gaussian pyramid: The idea of a gaussian pyramids are constructing smoothed copies of a given image at different scales. In the object detection phase, it is important to classify windows at multiple scales. This algorithm is written in python with the help of OpenCv library. may be pretty big. Smaller pictures mean our model can practice more quickly.

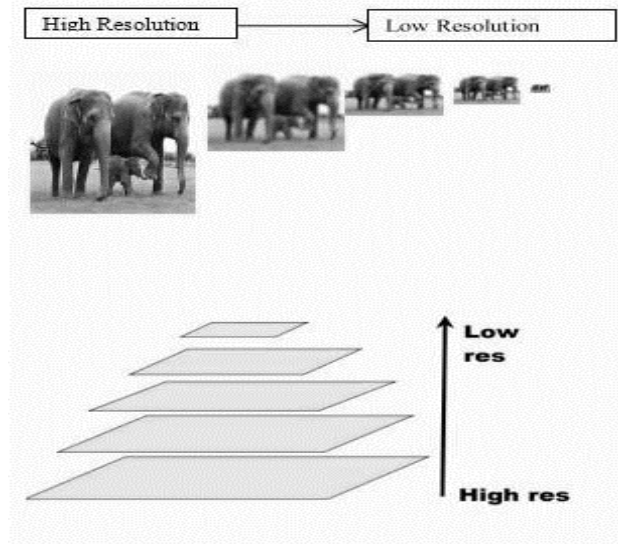

Figure 7. Gaussian pyramid

**Sliding window algorithm:** In the context of image processing and computer vision, a sliding window algorithm is simply a rectangular region of fixed width and height that slides across an image. For each window location we apply an image classifier to determine if the window has an object that interests us. We can construct image classifiers combined with image pyramids that can identify objects at varying sizes and positions in the picture. (Song and Zhang, 2008)

#### Results

##### A. Experimental dataset

Before train the model, need to gather lots of images. In here used 20500 images. Objects in terms of lighting and context should be different from one another so that the model can generalize better. Detailed information about the no. of images in each class are tabulated in Table 1.

Like this gather data and put that data into two folders, training dataset and testing dataset. After gathering the data, we need to resize our images because some of them

Further, the dataset is increased by performing image augmentation such as flip, rescale, zoom the image, and by varying contrast.

Combining a total of 10500 images are used. From 10500 image, 7000 images are used for training, and 3500 images are used for testing. Resizing of images with padding is performed to ensure that the images are of uniform dimension.

Table 1. No of images collected from different datasets

Name	Number of Elephants
Elephant	5000
Deer	800
Bear	600
Hen	3100
Tiger	950
Cat	50

1).*Dataset preparation:*The preparation of data sets plays a significant role in detecting elephants. The neural network will perform better if it is trained using a large dataset. Increasing the dataset will result in making our neural network to learn more feature and perform more accurate identification. In this paper, own dataset of images is collected from numerous website which includes many classes (elephant, bears, buffalo, cat, cheetah, deer, hen), where each class contains about an 10500 images as represented in Table 1. Data augmentation is performed to improve the invariance property of the images. The dataset split is about a 2:1 ratio.

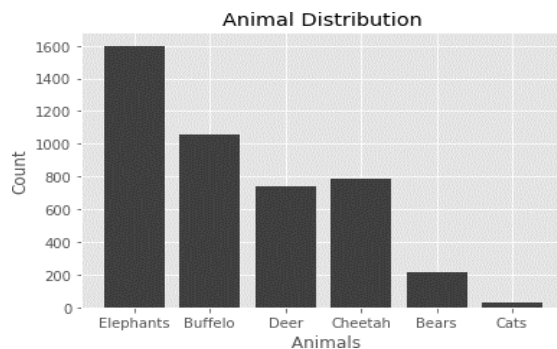

Figure 8. Summerized data graph

The collected dataset includes various image sizes of different aspect ratios. To retain the same size and aspect ratios, all images collected are redimensioned using an online image resize tool.



Figure 9. Sample images of elephants used for training(elephants, 2020)

2).*Data Augmentation:* Initially, the collected dataset contains images captured under controlled conditions but our target application is of a diversified condition such as variation in orientation, location, brightness, color, some added noises, etc. In order to overcome those conditional variation properties, the dataset is augmented in such a way that the invariance property is be minimized. The augmentation used for the dataset is Flip, rescale, and zoom.

### B.Feature Extraction

Features are extracted from the foreground. Here shape feature is considered. Orientation, eccentricity, major axis length, minor axis length, convex area, equidiameter, solidity, and extent are the shape features that are extracted from each of the segmented images.

### C.Recognition Results

Classification is done using CNN. Elephant acceptance is denoted by 'YES' and 'NO' otherwise. This elephant recognized as an elephant and all other animals are not recognized as elephants. The graph below shows the exactness and the loss of each epoch. A number of iterations here have

improved precision, too. The data set was divided into data sets for training and testing, and the accuracy of both data sets in iterations is seen in the two graphs below.

1) *Accuracy and Loss graph:* We got a very good accuracy as a result of checking the model: 90% after 50 epochs of accurate classification samples. We have decided to develop two parcels for this.

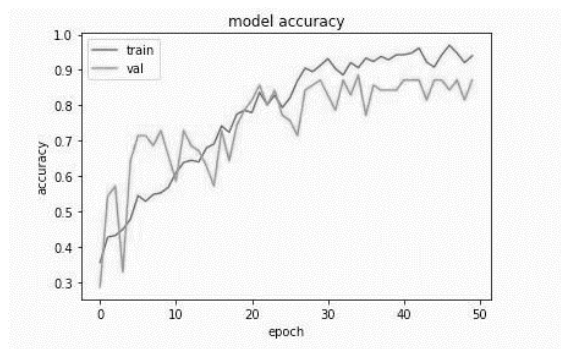

Figure 10. Accuracy with training and validation data

The first demonstrates how much the accuracy of the measurement depends upon the number of epochs. The accuracy of the evaluation was determined using 400 images from other datasets. The second plot demonstrates the exactness and validity of the number of epochs during the study.

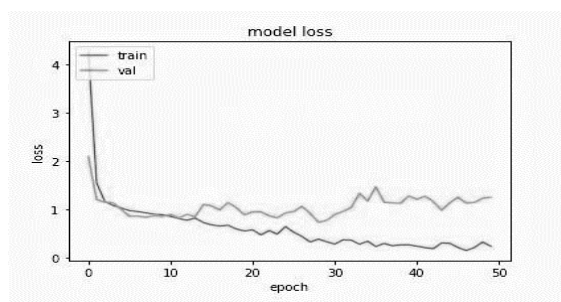

Figure 11. Loss with training and Validation data

2) *Object detection:* The recognition of objects in image processing is the method of in the image sequence or video search for a given target object. There are a number of 'features' in a picture of any object that is the best points on the item to be processed for output. Object information function. Such information derived from a target image

training will then be used to identify the object when attempting to locate the target object in the entire image that includes other objects in check.

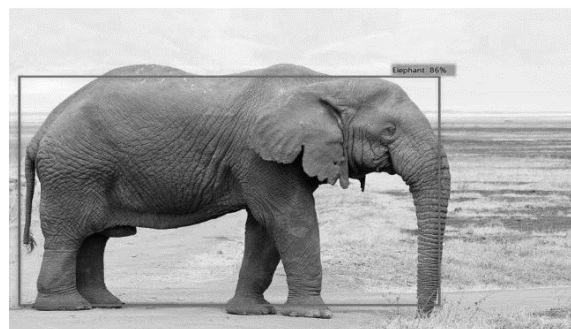

Figure 12. Result of the elephant detection

## Discussion and Conclusion

In conclusion, the findings of work contribute to elephant conservation issues. The work provides solutions to human-elephant conflict. The real-time elephant identification system provides solutions to the problem of human-elephant conflict in forest border areas and provides a solution for the unsupervised process of individual species identification specifically for elephants. Human-Elephant conflict have been continuously proposed and evaluated in the literature. The identification of artifacts has become one of the main fields of image processing. In this paper, the object is described as an elephant. More significantly, these findings show the importance of consistency in the detection of elephants entering human living spaces and provide early warning about the entry of elephants into human habitat. This technique of real-time image processing for recognizing an approaching individual elephant as well as a group of elephants.

The real-time automated solution minimizes manual work which is not always feasible because it is difficult to manually track the presence of elephants as the herd's march towards the forest boundaries.

## Acknowledgement

We would like to express our thanks to the team of the Department of Wildlife Conservation who collected the images, made it possible to publish this data-set and provided helpful feedback.

## References

- Ahmed, A., Jalal, A. and Kim, K. (2019) 'Region and Decision Tree-based segmentations for Multi-objects detection and classification in Outdoor Scenes', pp. 209–214. doi: 10.1109/FIT47737.2019.00047.
- Chhabra, A. and Kiran, M. (2017) 'Classifying Elephant and Mice Flows in High-Speed Scientific Networks'.
- Dhanaraj, J. S. A. and Kumar Sangaiah, A. (2018) 'Elephant detection using boundary sense deep learning (BSDL) architecture', *Journal of Experimental and Theoretical Artificial Intelligence*. Taylor & Francis, 00(00), pp. 1–16. doi: 10.1080/0952813X.2018.1552316.
- Dharmaratne, M. P. J. and Magedaragamage, P. C. (2014) 'HUMAN-ELEPHANT CONFLICT AND SOLUTIONS TO IT IN SRI LANKA.', 01, pp. 56–58.
- Fernando, P. *et al.* (2011) 'Current Status of Asian Elephants in Sri Lanka', 35, pp. 93–103.
- Hamdan, M. *et al.* (2020) 'Flow-Aware Elephant Flow Detection for Software-Defined Networks', *IEEE Access*. IEEE, 8, pp. 72585–72597. doi: 10.1109/ACCESS.2020.2987977.
- Joubert, D. (no date) 'The Aerial Elephant Dataset: A New Public Benchmark for Aerial Object Detection.'
- Matthias, K. *et al.* (no date) 'ELPephants: A Fine-Grained Dataset for Elephant Re-Identification'.
- Ogra, M. V. (2008) 'Human-wildlife conflict and gender in protected area borderlands: A case study of costs, perceptions, and vulnerabilities from Uttarakhand (Uttaranchal), India', *Geoforum*, 39(3), pp. 1408–1422. doi: 10.1016/j.geoforum.2007.12.004.
- Ramesh, G. *et al.* (2017) 'An Automated Vision-based Method to Detect Elephants for Mitigation of Human-Elephant Conflicts', pp. 2284–2288.
- Rumbles, K.- (2014) 'An Automatic Method to Detect the Presence of Elephant  $H(z)$  IT k = l k k z - ) a a k I- Lakz-', (978), pp. 1515–1518.
- S, A. S., Ramesh, M. V and Divya, P. (2016) 'Design and Simulation of Elephant Intrusion Detection System', (Wcse), pp. 17–19. doi: 10.18178/wcse.2016.06.134.
- S, M. S. (2014) 'Recognition of Elephants in Infrared Images using Mean-Shift Segmentation', (978), pp. 2–7.
- Sahlol, A. (2017) 'Elephant Herd Based Approach For Training Feed-forward Neural Network: A case study on Acute Lymphoblastic Leukemia Diagnosis', (March 2018). doi: 10.1109/ICCES.2017.8275387.
- Sensing, M. R. (no date) 'FAST ANIMAL DETECTION IN UAV IMAGES USING CONVOLUTIONAL NEURAL NETWORKS'.
- Seo, K. (2007) 'An application of one-class support vector machines in content-based image retrieval', 33, pp. 491– 498. doi: 10.1016/j.eswa.2006.05.030.
- Studies, P. and Lanka, S. (no date) 'Mitigating Human-Elephant Conflict in Sri Lanka: Can insurance play a role?'
- Suganthi, N., Rajathi, N. and M, F. I. (2018) 'Elephant Intrusion Detection and Repulsive System', (4), pp. 307–310.
- Tuba, E., Jovanovic, R. and Tuba, M. (2019) 'Brain Image Segmentation Based on Firefly Algorithm Combined with K- means Clustering', (July). doi: 10.24846/v28i2y201905.
- Zeppelzauer, M., Hensman, S. and Stoeger, A. S. (2014) 'Bioacoustics: The International Journal Towards an automated acoustic detection system for free-ranging elephants', (December), pp. 37–41. doi: 10.1080/09524622.2014.906321.

## Author Biographies



K.S.P. Premarathna is an undergratuate student in the Sabaragamuwa University of Sri Lanka and will be gratuating in 2020 with a BSc special in Information Systems. She is

interested in doing researches related  
computer vision areas.



DR. M. Kapila Tharanga Rathnayaka is presently working as a senior lecturer in Statistics, Faculty of Applied Sciences, Sabaragamuwa University of Sri Lanka. He highly interested to do research in the field of Financial Mathematics, Time series Modeling and Data Mining approaches.

## Computer Vision Based Approach for Traffic Violation Detection

Akila Peiris<sup>1</sup>, EATA Edirisuriya<sup>2</sup>, CD Athuraliya<sup>3</sup>, Isuru Jayasooriya<sup>4</sup>

<sup>1,2</sup>*Department of Computer Science, Faculty of Applied Sciences, University of Sri Jayewardenepura, Sri Lanka*

<sup>3,4</sup>*LIRNEasia, Colombo, Sri Lanka*

#ananda@dscs.sjp.ac.lk

**Abstract** -The ever growing number of vehicles in a country present a variety of problems including but not limited to; infrastructural problems, air and water pollution and accidents with the latter being the most apparent. The main cause for this being traffic violations. This research was carried out with the intention of detecting motor traffic violations using CCTV footages. While there have been attempts to create automated traffic violation detection systems over the years, these studies have mostly been focused on more streamlined and sparse traffic conditions such as highways. But, the type of traffic conditions observed in Sri Lanka among other developing countries are unruly and chaotic. This paper proposes an automated real-time traffic violation detection system for highly congested and unruly road traffic conditions. The proposed system uses computer vision techniques, machine learning technology in creating a traffic violation detection system.

**Keywords** - Computer Vision, Traffic Violation Detection, Kalman Filter, Haar Detection.

### Introduction

The ever growing number of vehicles on roads present numerous problems to a country. Especially in a developing country like Sri Lanka where the existing infrastructures are insufficient to cater to all these vehicles. Two of the biggest problems posed by this vehicle population are traffic accidents and heavy traffic congestion. These are caused largely due to negligence and violation of traffic rules. In Sri Lanka, the existing methods for detecting traffic

violations are highly dependent on the police personnel thus, subject to human error. The idea here is to analyze the inputs gathered in the form of CCTV footages by utilizing computer vision and machine learning concepts. The reason for using CCTV infrastructure as the data source is due to the fact that, the infrastructure is easy to implement, maintain and expanded.

### Problem Definition

The challenge was to create an automated motor traffic violation detection system using CCTV footage that may facilitate ease of enforcing law and can be integrated into a complete advanced urban traffic management system. This system had to be feasible and easily maintainable to be implemented for a developing country. And the system must be robust against unruly traffic conditions.

### Literature Review

The methodological pipeline used in most of the previous works has several common steps; vehicle (object) detection, vehicle identification, tracking and traffic violation detection.

A research paper[1] proposed a way to detect vehicles using Gaussian mixture model. Detecting traffic violations is based on event detection. And events have to be considered as spatiotemporal data. Hence the goal of event detection is to identify spatio-temporal patterns of a particular nature.

A team of researchers have developed a system[2] to detect spatio-temporal patterns

(human actions) such as picking up a dropped object or waving a hand in videos of crowded areas. This system uses spatiotemporal shapes for event detection in highly dynamic and cluttered videos. The spatio-temporal event parts and their configurations are matched to a template to identify the events.

A research paper[3] has provided a comparative analysis and evaluation of Linear and Unscented Kalman Filters process models for urban traffic applications.

A team of Korean researchers proposed an image processing algorithm[4] for individual vehicle trajectory monitoring. This is done by utilizing detailed information such as speed, volume, etc. on each individual vehicle and conflict evaluation techniques.

A system, capable of counting and tracking vehicle speeds and trajectories in multi-track highways, has been proposed in an article[5] In this system, Foreground detection is done by utilizing the Gaussian

Mixture Model and then the detected foreground is morphed to reduce noise. Tracking is done using Kalman Filter. Gaussian Mixture Model handles illumination and background variation automatically.

A group of researchers[6] have developed an algorithm to address the issue of occlusion in traffic monitoring systems. They have developed an algorithm, called the Spatio-temporal Markov Random Field model which tracks each pixel in each frame and their transitions on a two-dimensional plane through the set of frames (time). And combining this with Hidden Markov Model (HMM) they have developed a system to detect traffic violations at intersections by identifying event chains.

## Methodology

### Vehicle Detection

After testing multiple methods of object detection varying from simple background subtraction methods to state of the art Deep learning methods such as Faster RCNN, we have selected Haar Cascade detection as the object detection technique for this system for its performance and accuracy.

Initially developed as a solution for face detection issues, this method can be trained to detect any form of object classes. Haar cascade uses a sliding window technique to test all possible positions to determine whether one or more objects of interest exist within the image[7].

In order to use Haar detection, first we have to train a Haar cascade classifier using a set of positive (images of objects of interest, in this case vehicles) and a set of negative (images of non vehicular objects) images which are approximately the same size. this previously trained classifier is then used in determining whether an area on an image contains an object of interest (vehicle) or otherwise.

The results are returned as bounding box positions in the (left x coordinate, top y coordinate, right x coordinate, bottom y coordinate) format.

After the initial detection, it is done at a discrete interval of the frame sequence (once in every 4 frames) and the detected data(bounding box positions) are compared with the bounding box positions of the existing KalmanBoxTracker objects(tracking data objects) using an Intersection Over Union (IOU) matrix.

If the newly detected objects do not correspond to any currently existing tracking data objects, they are passed into the next phase of the pipeline.

The tracking objects with a corresponding detected objects, the hit streak attribute is



increased by 1 and time since update attribute is set to 0 in the corresponding KalmanBoxTracker object. This attribute keeps the score of how many consecutive track detect position matches each tracking object has observed.

3) If there are tracking objects that do not correspond to any of the detected objects, the hit streak attribute is set to 0 and time since update attribute is increased by 1 in the corresponding KalmanBoxTracker object. If the hit streak value falls below the number of minimum number of hits or the frame count exceeds the minimum number of hits while the time since update is 0, the object is removed from the tracking object list.

hit\_streak attribute keeps track of the number of consecutive of a particular object. time since update attribute keeps track of the number of frames processed since the hit streak attribute is updated. (A hit is a bounding box of a tracked object which shares an IOU value of more than 0.5 when compared to the bounding box of a detected object.

### Vehicle Tracking

Then the results obtained from the haar detection are converted into the (x coordinate, y coordinate, bounding box area, width to height ratio) format.

These bounding box values are then fed into an instance of a model called KalmanBoxTracker along with a unique id assigned to each object. Then the newly created KalmanBoxTracker object is inserted into a list of such objects. This list holds the information about all the objects being tracked. During the data association phase, objects representing the newly detected objects are added and the objects which are found obsolete are removed from the list Kalman filter[8], or Linear Quadratic Estimation (LQE) is an optimal estimation algorithm. It was first used in the 1960s where it was used in the Apollo project to

calculate the trajectory of spacecrafts. Kalman filter has 2 main usages; it can be used to estimate system states that cannot be measured directly using indirect measurements and it can calculate the optimal measures of state by combining measurements from multiple sensors when the measurements are prone to noise.

Kalman filter combines the measurement and the prediction from the mathematical model to predict an optimal value for the next location of an object. In our context, this is very useful in situations where partial or complete occlusion is present.

### Violation Detection

The traffic violations are identified using the angles of the edges that connect the points of the vehicle's path.

For this purpose, we have selected to detect a specific type of traffic violation, disobeying lane laws, i.e. vehicles changing the travel path rapidly/ suddenly. We have used our own mechanism here to calculate the angles of the path of the vehicles. For every frame, we calculate the angle between 2 lines that connect the current position ( $P_k$ ) and the 2nd previous position ( $P_{k-2}$ ).

2nd previous position ( $P_{k-2}$ ) and the 2nd point previous to that ( $P_{k-4}$ ).

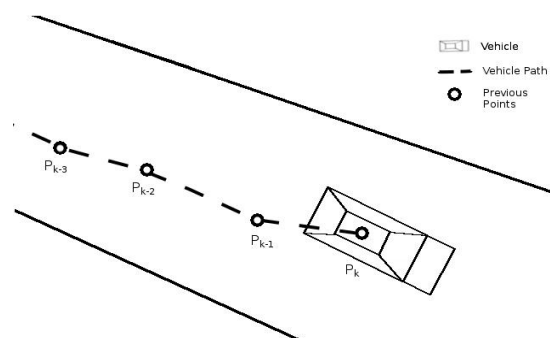

Figure 1: Vehicle path and previous positions

i.e. in a series of points where the current position is ( $P_k$ ), previous position is ( $P_{k-1}$ ) and so on, we calculate the angle made at ( $P_{k-2}$ ) by points ( $P_k$ ), ( $P_{k-2}$ ) and ( $P_{k-4}$ ). and if the angle

exceeds a certain value, the system detects it as a violation.

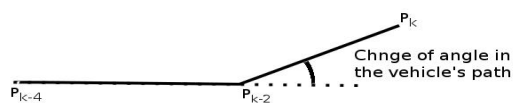

Figure 2: Change of angle

The reason that we calculate the angle by skipping a previous position (angle between  $P_k$  and  $P_{k-2}$  instead of  $P_k$  and  $P_{k-1}$  and so on is to reduce the effects of noise and small errors of the predicted tracking positions.

## Results



Figure 3: A violation being detected

The system we have developed produces results with a high MOT A (Multiple Object Tracking Accuracy) value when considering tracking accuracy. The overall system has a MOT A (Multiple Object Tracking Accuracy) value of 0.90. This value was achieved by testing 5 sets of frames, with each set having 80 frames.

The overall system was able to identify 2 out of 3 lane rule violations committed by the vehicles it tracked.

## Conclusion

Since the system is pipelined, a bottleneck in accuracies in any stage affects the accuracies in the next stage. Therefore, it is important for the detection method to achieve a low false negative rate to achieve higher accuracies in tracking and violation detection stages. Using a set of predefined areas to conduct detection and tracking and

combining the results together can improve the speed and overall accuracies of the results. This is because we can avoid tracking vehicles that are too far and limit our scope to one direction at a time which is especially in complex junctions.

## References

- N. Hirata, H. Okuda, M. Seki, and M. Hashimoto (May 2005), "Vehicle detection using gaussian mixture model for infrared orientation-code image," *Optomechatronic Machine Vision*.
- Y. Ke, R. Sukthankar, and M. Hebert (2007), Event detection in crowded videos, *IEEE 11<sup>th</sup> International Conference on Computer Vision*
- C. Aydos, B. Hengst, and W. Uther (2009), "Kalman filter process models for urban vehicle tracking," *12<sup>th</sup> International IEEE Conference on Intelligent Transportation Systems*.
- J. Oh, J. Min, M. Kim, and H. Cho (2009), Development of an automatic traffic conflict detection system based on image tracking technology, *Transportation Research Record: Journal of the Transportation Research Board*, vol. 2129, p. 4554, 2009.
- Z. Iftikhar, P. Dissanayake, and P. Vial (2014), Computer vision based traffic monitoring system for multitrack freeways, *Intelligent Computing Methodologies Lecture Notes in Computer Science*, p. 339349, 2014.
- S. Kamijo, Y. Matsushita, K. Ikeuchi, and M. Sakauchi (2000), Traffic monitoring and accident detection at intersections, *IEEE Transactions on Intelligent Transportation Systems*, vol. 1, no. 2, p. 108118.
- P. Viola and M. Jones (2001), Rapid object detection using a boosted cascade of simple features, *Proceedings of the IEEE Computer Society Conference on Computer Vision and Pattern Recognition. CVPR 2001*.
- R. E. Kalman (1960), A new approach to linear filtering and prediction problems, *Journal of Basic Engineering*, vol. 82, no. 1, p. 35, 1960.

## Acknowledgment

The authors would like to thank the Department of Police Sri Lanka for providing the CCTV footages necessary for the research. And to Miss Ayesha Dedigama for the support given throughout this research.

## Projection Profiling Based Sinhala Braille Character Recognition and Conversion

Major W Randika Ariyaratna<sup>#</sup>, Lieutenant Colonel L Rasika Kahandagamage (Retd) RSP  
and MajorWMP Wasantha Kumara (Retd)

*Centre for Research and Development (CRD) – Ministry of Defence, Sri Lanka*  
<sup>#</sup> randikaariyaratna@gmail.com

**Abstract:** The instantaneous conversion of written Braille characters to readable, colloquial text of the particular language it was written in, has been a hurdle for many sighted personal. Various solutions have been proposed in this regard and many solutions are available to convert Braille to different languages. However, there are very few attempts to do the same for Sinhala Braille symbols and at present widely using conversion method is to use an individual well versed in both Sinhala language as well as Sinhala Braille characters. As such, a considerable delay occurs in the translation process. Hence the visually impaired academics and students, as well as soldiers visually impaired due to war, who work with Braille encounter many hardships. Their teachers and superiors also have faced numerous problems as they are unable to understand Braille. One such consequence is that students sitting for exams face delays in receiving exam results as translation from Braille to Sinhala introduces additional delays in addition to often the context being lost in translation.

Proposed conversion engine will easily convert the Sinhala Braille text on papers to the corresponding Sinhala text and will assist the learning and communication processes of visually impaired citizens of Sri Lanka. The Braille printed documents to be converted through this software need to be subjected to image pre-processing, projection profiling and Braille recognition processes, capturing a picture of the Braille characters on a sheet

initiates the process. Six dots are used to create Braille symbols. This system identifies these distinct symbols using a specially constructed framework and algorithms, followed by comparing them against a database of symbols in the recognition process and the final output is derived using the Sinhala alphabet.

**Keywords:** Braille symbols, image pre-processing, projection profiling

### Introduction



Figure 1. A Braille cell

There are not many person able to read Braille. Therefore it is necessary to research, assistive technology to translate Braille in to text to make it easier to read (Subur, Sardjono, and Mardiyanto, 2016). Simply, the paper communication between the visually impaired people and non-blind people have become a problem that need to be addressed (Perera, and Wanniarachchi, 2018). Braille recognition systems can bridge the communication gap between the visually impaired and people with unimpaired vision. By being a digital guide to non-Braille academics, this system is expected to expedite the exam paper evaluation process of visually impaired students so that the release schedule for them occur parallelly with the ordinary students and therefore shall effectively

reduce or abolish the waiting time for their results. Also the visually impaired Sri Lankan citizens can move forward in their life at the same pace with general public. It also could work as a more credible method of translation which avoids the inaccuracies caused by human errors in the process of manual translation. Hence, it possesses the effect of assisting visually impaired student to fill the gap faced when navigating in a fast paced digitally integrated modern society.

There have been attempts to recognize Braille documents using the setups of a camera (Subur, Sardjono and Mardiyanto, 2016; Taha, 2014; Venugopal-Wairagade, 2016) and commercially available scanners (Wong, Abdulla and Hussmann, 2004; Antonacopoulos and Bridson, 2004; De Silva, Srilal, Athapaththu and Ranathunga, 2016) for different languages world wide (AlSaleh, El-Zaart and Al-Salman 2011; Shreekanth and Udayashankara, 2015; Kitchings, Antonacopoulos and Drakopoulos, 1995). This paper presents a method of Braille cell extraction from a digitized single sided Braille paper followed by the recognition of Braille character patterns. This aims at generating quick results for the sighted persons who need to understand visually impaired persons.

Section II of this paper will present the methodology proposed and the algorithms involved describing all the four main system processes. Section III presents test results, which are discussed in the same section.

### Methodology

The embossing of Braille dots can be on a single side or on both the sides of the Braille sheet. The data contained in the single sided Braille document is less than a double-sided Braille document for the obvious reason that the information present is only on one side. However, single sided Braille paper is simpler in nature to scan via image processing techniques. Therefore,

henceforth the research is focused on the single sided Braille documents.

The development was done in the C++ development environment with OpenCV image processing library. The system goes through four (04) major steps as shown in Figure 2.

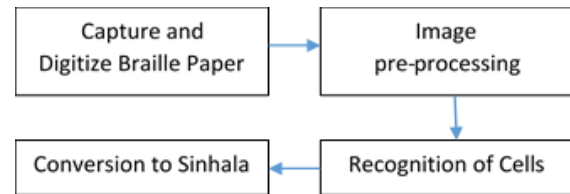

Figure 2. System process and features

#### A. Capture and digitization of Braille paper

For this research it is used single sided Braille documents written in Sinhala language. Also can use either standard document scanners or specially designed Braille document digitizer for acquiring the input image before the preprocessing task. The Braille document digitizer illuminates the Braille paper with LED in Green colour light and captures the image using Nikon D3400 24.2 MP Digital SLR Camera for obtaining relatively high resolution image. Several light sources and colours were tested and it was found that Green light was best suited to providing a high degree of contrast between the raised Braille portions of the paper and the flat ones. LED strips are positioned all around the interior to provide illumination from each edge of the Braille paper and to get highlighted the embossed dots.

Figure 3 shows the digitizer based input acquisition.

The scanner was constructed to extract the best possible image in terms of pixel density and clarity, accommodating the optimal focal length for the camera used and to mount the camera so as to eliminate movements that may introduce errors. The interior of the scanner was sealed from external influences such as wind and light that might interfere in

the image processing. The tray for placing documents is designed to enable the rapid placement of the Braille document in the correct position, correct alignment and correct orientation every single time.

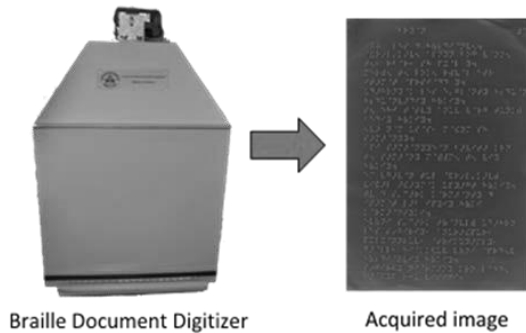

Figure 3. Digitizer based input acquisition

The resultant scanner mechanism is capable of capturing Braille sheets with a high degree of clarity and speed without compromising the integrity of the paper and embossed characters than any external or flatbed scanner. It does the process much faster owing to the extremely fast image capture time of the digital camera and the possibility of immediately accessing the image afterwards.

*B. Image pre-processing*

The acquired image is now subjected to image preprocessing. Initially, crop the full Braille cell area or required area to be converted from the input image using OpenCV implementations. If there is any rotation on the input image, corrections could be done. De-skewed image is now converted in to a grayscale image using OpenCV *CV\_RGB2GRAY* implementation. Next, the grayscale image is converted in to a binary image using *cvThreshold* function. At this stage all the embossed Braille dots that were present in the cropped image is represented in black dots with few unwanted noise. To remove that noise it is used the Erosion followed by Dilation on binary image using *cvErode* and *cvDilate*. By now there is an image which is noise free / less to further process. Figure 5 represents the pictorial flow of image pre-processing processes.

*C Recognition of cells*

On noise filtered binary images it is performed a full horizontal projection profiling comparing against the cell height in pixels, to identify the Braille rows without partial data on the cropped input image. Identified rows are shown in Figure 4.

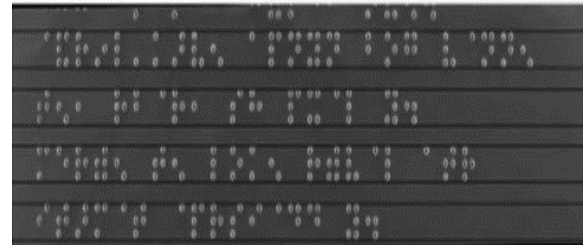

Figure 4. Identifying rows

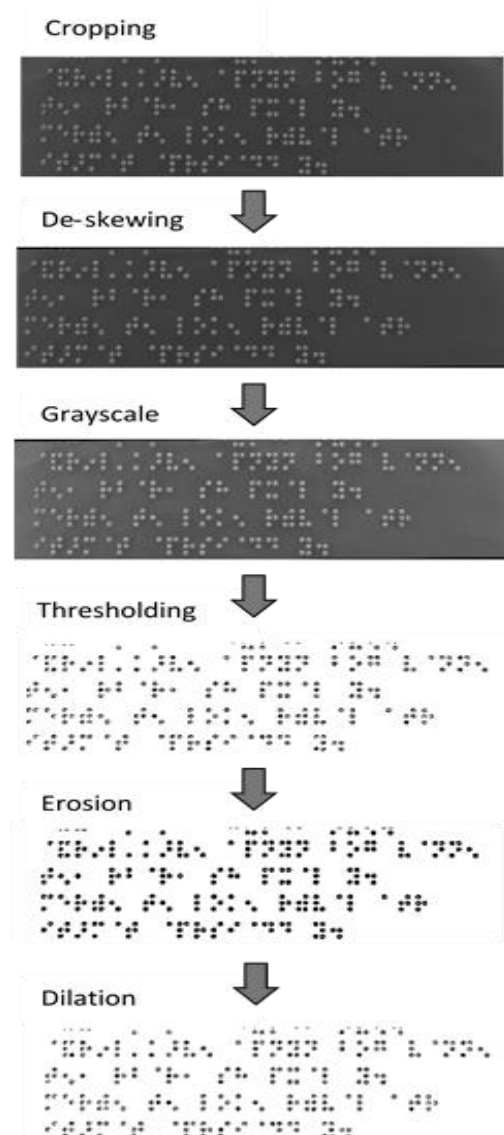

Figure 5. The flow of image pre-processing

Now perform a vertical projection profiling on each identified row comparing against the cell width in pixels, to derive best left and right boundaries for each and every Braille symbol. At the end it has the coordinates of the four (04) edges of all the Braille cells on the selected area to be recognized. Best possible left and right boundaries are shown in Figure 6.



Figure 6. Identifying all cell boundaries

#### D. Conversion to Sinhala

It is assigned an integer to each dot segment of a single cell as shown in Figure 7.

1	32	4	4
2	16	5	2
3	8	6	1

Figure 7. Assigned integer to each dot segment

If a binary data is present on each dot segment, add corresponding integers together. All the final integers are mapped to the Sinhala Alphabet. Complexity of Sinhala Braille to represent Sinhala text is also addressed in this way. As an example Sinhala characters with upper and lower connections (Figure 8) get broken down as single characters in Braille. After mapping each and every connection from the Sinhala alphabet, the final Sinhala letter is displayed to the user.

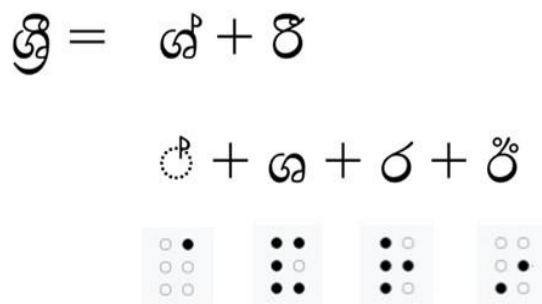

Figure 8. How Sinhala 'ඌ' character is represented in Sinhala Braille system

After mapping all the Sinhala Braille letter combinations to the Sinhala alphabet, the final output is displayed as shown in Figure 9.

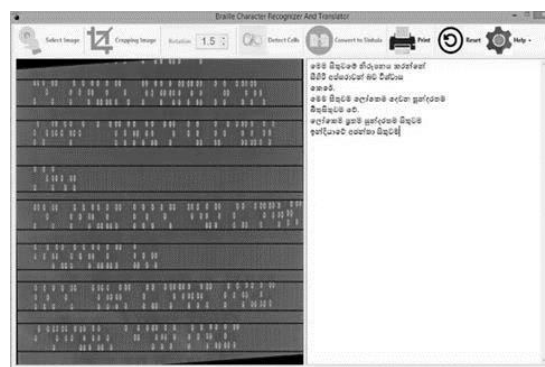

Figure 9. Visualization of converted output

### Results and Discussion

The system has been tested with a wide variety of single sided, scanned, printed and typed Sinhala and other languages' Braille documents. Character translation achieved up to 92% success rate. Typical failure cases in the single sided documents such as worn marks, paper defects and noises, directly affected on the success rate.

Conversion of other global languages' Braille documents to relevant native languages also showed with promising results using the same algorithms. Few results can be shown as follows (Figure 10).

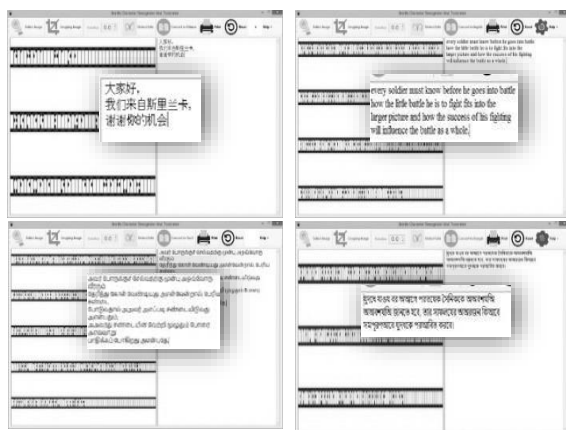

Figure 10. Support for native languages globally

The system was found to be simple and easily usable with minimal instruction. When used in conjunction with other Sinhala to Braille conversion tools, it proved to be helpful, enabling even the military personnel who are visually impaired due to the war to integrate back to the society and to be productive with a purpose.

Our further work is focused to recognize double sided Braille documents, carry out noise cancellation process and gain higher success rate in character recognition. In future iterations, it is envisioned to modify the enclosure to reduce the size and make it more compact, based on a more suitable higher resolution camera and to deploy the system as a Cloud Service to be used by other organizations globally. The ultimate aim being to make the system ubiquitous, simple, mass producible and to make it possible to have a device present for the use in any institution or individual who works with visually impaired citizens.

## Conclusion

Along with these features now there is a rapid, user friendly, easy to use and cost effective, all in one system which has quick response time based on the user experience. Also, the combined algorithms have the potential to solve the problems in vegetation counting, hand writing segmentation, number plate recognition, aerial image

analysis, remote sensing and inscription character recognition etc.

This paper proposed an algorithm to optically recognise embossed single sided Braille documents through image processing and do so in an easily accessible manner. Thus, it would be possible for the visually impaired to be more productive and engage more with the society at large and move forward with their lives at the same pace as else, as epitomised by the nature of the ever-integrated digital world we live in.

## References

- Al-Saleh, A., El-Zaart, A. and Al-Salman, A.M., 2011. Dot detection of Braille images using a mixture of beta distributions. *Journal of Computer Science*, 7(11), p.1749.
- Antonacopoulos, A. and Bridson, D., 2004, September. A robust Braille recognition system. In *International Workshop on Document Analysis Systems* (pp. 533-545). Springer, Berlin, Heidelberg.
- De Silva, W.C.N., Srilal, N.C., Athapaththu, H.B. and Ranathunga, L., 2016. Novel Segmentation Method for Optical Braille Character Identification.
- Kitchings, R.T., Antonacopoulos, A. and Drakopoulos, D., 1995. Analysis of scanned Braille documents. *Document Analysis Systems*, Bd, 14, p.413.
- Perera, T.D.S.H. and Wanniarachchi, W.K.I.L., 2018. Optical Braille Translator for Sinhala Braille System: Paper Communication Tool Between Vision Impaired and Sighted Persons. *The International Journal of Multimedia & Its Applications (IJMA)* Vol, 10.
- Shreekanth, T. and Udayashankara, V., 2015. A New Research Resource for Optical Recognition of Embossed and Hand-Punched Hindi Devanagari Braille Characters: Bharati Braille Bank. *International journal of image, graphics and signal processing*, 7(6), p.19.
- Subur, J., Sardjono, T.A. and Mardiyanto, R., 2016. Braille Character Recognition Using Find Contour And Artificial Neural Network. *JAVA Journal of Electrical and*

Electronics Engineering, 14(1).

Taha, H.M., 2014. Robust Braille recognition system using image pre-processing and feature extraction algorithms (Doctoral dissertation, Universiti Tun Hussein Onn Malaysia).

Venugopal-Wairagade, G., 2016. Braille recognition using a camera-enabled smartphone. Int J Eng Manuf, 4, pp.3239.

Wikipedia. 2020. Braille - Wikipedia. [Online] Available at: <https://en.wikipedia.org/wiki/Braille>. [Accessed 16 June 2020].

Wong, L., Abdulla, W. and Hussmann, S., 2004, August. A software algorithm prototype for optical recognition of embossed Braille. In Proceedings of the 17th International Conference on Pattern Recognition, 2004. ICPR 2004. (Vol. 2, pp. 586-589). IEEE.

### Acknowledgment

The authors would like to thank, The School for the Blind, Ratmalana, Sri Lanka for being the knowledge partner since the early stages of the project, providing invaluable insight and feedback. Additionally, the authors wish to thank the Centre for Research and Development, Ministry of Defence – Sri Lanka for being the technical partner throughout the process all the way through to its successful completion.

### Author Biographies



Major Randika Ariyaratna. A Graduate of University of Colombo School of Computing from the field of Computer Science. Currently attached to the Explosive, Armament, Ammunition and Ballistic Wing - CRD.



Lieutenant Colonel LRK Kahandagamage (Retd) RSP. A Geographic Information System and Remote Sensing specialist as well as a former Chief Coordinator of IT/GIS Wing - CRD. Followed a Masters Degree at University of Sri Jayewardenepura.



Major WMP Wasantha Kumara (Retd). A Geographic Information System and Remote Sensing as well as a former Research Officer at the IT/GIS Wing CRD. Followed a Masters Degree at University of Sri Jayewardenepura.



## Real-Time Traffic Controlling Through Multi-Agent Technology

RT Wakkumbura, B Hettige#, EATA Edirisooriya

*Department of Computer Engineering, Faculty of Computing General Sir John Kotelawala Defence University*

#budditha@kdu.ac.lk

**Abstract:** In Sri Lanka, most of the traffic controlling happens through a fixed time controlling and runs on a static environment. However, these traffic control systems are not much effective compared to human-based traffic control. This research is focused on the design and development of a multi-agent-based real-time traffic controlling system that should be capable of controlling traffic effectively. The proposed multi-agent system technology is one of the modern software techniques, capable of handling complexity in the dynamic environment. Thus, the multi-agent system has been designed with a vehicle, junction, and passengers are considered as agents. Traffic control has been arranged through communication among agents. As the initial stage of the research, traffic behaviour was simulated through the NetLogo simulation tool. The efficiency of the traffic controlling was calculated for the three different approaches including, an uncontrolled way, time-based static method, and agent-based controlling. According to the simulated results, agent-based traffic control provides remarkable efficiency than the other existing methods.

**Keywords:** Traffic congestion, Multi-agent Systems, Control

### Introduction

Moving toward a digital world almost all the fields in a country face challenges. Road transportation is one field that develops with various challenging factors like vehicle density, climatic changes, infrastructure, etc. With these challenges, traffic congestion is a

growing problem in transportation. According to the 2019 Urban mobility report (Schrank et al., 2019), most of the workers are on the road around 8.00 a.m. and 5.00 p.m. which are named rush hours. In these hours people who use both public and private transportations face delays due to traffic jams. In Sri Lanka, Colombo is the commercial capital and largest city. 7.8 million passengers' daily travel in and out to the Colombo region. Therefore, the average travel speed in Colombo drops to 10km per hour. It is expected that the passengers entering the Colombo region will increase by 4.4 million in 2035. There are 7.4 million vehicles in Sri Lanka and 70% of the roads hold traffic jams. Because of this heavy traffic congestion, Sri Lanka lost 1.5% of the GDP. Most of these traffic jams occur near junctions where traffic light systems are used to control the traffic. The main problem in this system is the way of allowing vehicles to cross junctions. This existing traffic control system in Sri Lanka and most of the countries are preprogrammed and timed based (M. Tomizuka, and P. Varaiya, n.d.). The periods are set according to two categories as peak hours and off-peak hours. Normally morning evening and night counts as peak hours and early mornings and midnight as off-peak hours. Although it is categorized as above, the system is still pre-timed and cannot be changed according to the situation. This causes serious problems especially near junctions because this system cannot change according to the actual traffic density and its roots to heavy traffic jams. When there are two consecutive junctions, a lot of time and

fuel get wasted. Sometimes along with the current traffic control system, police officers are also assigned to intersections. These traffic jams not only waste time but also give people stress, accidents, intention to break the law, etc.

There are various systems implemented for traffic controlling situations in the world. Among them (Arel et al., 2010),(Omar, 2015), and (Qingming et al., n.d.) are some of the traffic control systems proposed or developed using various technologies like reinforcement learning, fuzzy logic, IoT, distributed systems, learning classifier systems, and image processing. Commonly used technologies are fuzzy logic controllers and reinforcement learning. Almost all the systems developed as software simulations or as design models. Many systems are designed using common strategies like designed algorithms, mathematical functions, and models to cope with system complexity. Those systems address the traffic congestions in urban areas while a limited number of them address the traffic specifically in four-way junctions with the above ideas, the research has been conducted to develop an intelligent traffic control system through the multi-agent system technology.

The rest of the paper is organized as follows. The second section gives a brief review of related works including multi-agent system technology and some existing traffic control systems. The third section describes the design of the proposed system including ontology, agent model, and communication diagram. Section four demonstrates the simulation setup of the system including a detailed description of three approaches we are going to test. The last section reports the conclusion with further works of the project.

## Literature Review

### A. Multi-Agent System Technology

Multi-Agent System is one of the co fields that come under Artificial Intelligence. The main element in the Multi-agent System is called an “Agent-based system”. An agent has the autonomous action capability and multiple interaction ability. Simply agent is an entity that interacts with its environment. Here the environment may be a real or virtual space where the agent lives in. The use of agent concepts can be categorized into three levels as an organization, interaction, and agent level. According to main features in multi-agent systems (Graham Low and Quynh Tran Nhu, n.d.) capacity is limited in each agent, no global control, each agent has a partial point of view, decentralized data in the system and asynchronous calculations. Main Multi-Agent System applications areas include networks, distributed/concurrent systems, and human-computer interfaces. Multi-Agent technology can be used in situations where a problem cannot perfectly solve through algorithmic solutions. The problems solved through Multi-Agent Systems cannot be explained through flowcharts. Traffic congestion is also a similar problem. As in (Vlassis, 2007) some advantages of using Multi-Agent System technology in large scale software systems like traffic controlling are cost, robustness, scalability, speed, efficiency, reliability, flexibility, development and reusability. Multi-Agent software is different from conventional software. Multi-Agent software is a network of software agents, but conventional software is an application designed to perform a specific task. The differences between this two software are shown in Table I. Multi-Agent System technology can be applying to different large-scale complex systems to make the work effective. This technology gives the ability to transfer from a single intelligent model to a multi intelligent model that represents a human intelligent acting model. The next subsection briefly reports some related traffic control systems.

*Table 1. Software Comparison*

	Multi-Agent Software	Conventional Software
Process	Parallel	Sequential
Behaviour	Emergent	Preprogrammed
Decision	Distributed	Centralized
Approach	Knowledge-driven	Data-driven

## B. Related Works

This section focused on the existing traffic control systems and their related functions. The current method used in Sri Lanka is a pre-programmed time-based controlling system (How Do Traffic Signals Work? 2006). This method did not address the problems that occur in current traffic management. It makes the situation more complex. As an example, though there is no vehicle on the road the system gives the priority to that road according to the program. (Arel et al., 2010) developed a reinforcement learning-based multiagent system for efficient traffic signal control. The system suggests a multi-agent and Reinforcement learning framework and aims to optimize queuing delays by scheduling traffic signals at junctions. An algorithm was implemented to identify heavy traffic jams or the longest queue first. (Khaled et al., n.d.) developed an intelligent decision support system to control road traffic. In this system, an intelligent agent was assigned to assist human operators in the traffic control center. The system was designed as a collection of a subnetwork that supports intercommunication. Each agent was designed to perform three functions, monitoring and detection, traffic control, and traffic device control. (Pierre-Luc Gregoire et al., 2007) developed a learning agent-based traffic control system. Here an intelligent learning agent was created to control the traffic. The agent was created to learn the control policy with the help of machine learning algorithms to adapt to the system.

That was specially designed to control traffic congestions at intersections.

An intelligent traffic information system based on a combination of the Internet of Things (IoT) and agent technology was developed by (Omar, 2015). It is an IoT agent-based system to collect traffic information to provide a solution to this traffic problem. The system operates with mobile agent technology. All the traffic data is collected through RFID in each vehicle and sent to the server for analysis. But using a large no of RFID is an obstacle for the improvement of security factors. Zenjiang et al. proposed an agent-based distributed and adaptive platform for the transportation system (Qingming et al., n.d.). The signal control module consists of different agents' - responses to various conditions. The module runs on the traffic controller application-specific operating system for real-time operation.

Fuzzy logic controller for a traffic junction was proposed by (C. P. Pappis ; Ebrahim H. Mamdani, n.d.). The controller was designed and compared with the actuated controller. The design model is implemented by assuming the arrival of vehicles to junctions being random. The model compiled many times for reliable results. A traffic junction controller by applying a classifier system together with fuzzy logic was designed by (Cao et al., 1999). The designed fuzzy controller connects the traffic condition and traffic lights via a classifier system. The classifier system was tested with both reinforcement and evolutionary learning that determine control rules in a dynamic environment. A real-time traffic signal control system architecture and algorithm were proposed by (Mirchandani and Head, 2001). The paper discusses mainly the system architecture, designed algorithm, and analysis. The system provides four main functions as chunking the traffic problem into subproblems, predict traffic flows, use

optimization modules to solve subproblems, and utilize approaches that give fast solutions. The street detectors monitor the traffic and use the data to predict future traffic streams. The controlling process was done through algorithms like intersection and flow control.

(Blosseville et al., 1990) designed and developed a traffic measurement system with the use of the image processing technique. An algorithm was developed with various traffic images obtained from intersections and roads. Further, the algorithm was created with the ability to recalibrate to detect lanes. The system consists of various modules as line detection, vehicle detection, vehicle tracking, and detection in saturated traffic. The system dedicated hardware is still under development to build new modeling of traffic behaviour. (Walad and Shetty, 2014) proposed a traffic light control system using image processing. The basic operation is vehicles were detected using image processing, analyze the traffic, and control the traffic lights according to traffic density. The system comprises hardware, software, and interfacing components. The edge detection was used to declare the presence of vehicles and roads with high vehicle density get the priority and along with that time is also used as a parameter in the operation process. The systems avoid the waste of time happening in the existing system with priority, but the accuracy is not a hundred percent confirmed in both systems.

(Péter, 2012) proposed a nonlinear road traffic network to control the junction traffic. A specially developed mathematical model was used and through that, it examines the non-linear equation system. The regulations and large-scale traffic system can be tested using this model. Apart from that, this model is designed to use directly for simulations and analysis. Based on real-time vehicle density, the model is designed to provide

instructions for traffic canters to avoid traffic jams. (Bull et al., 2004) proposed a distributed adaptive traffic control using learning classifier systems. This approach gives the ability to develop signal control strategies according to the performance. The learning classifier system was used mainly because its rules were interpreted as action controlling, a mathematical function adopted to transform traffic measures and choices of measures of traffic conditions. (Di Febraro et al., 2004) designed a traffic control structure using Hybrid Petri Nets (HPN). HPN model is used to supervise the controller in the system and to describe vehicle flow by discrete event models and represent traffic dynamics. The model uses traffic coordination to give priority to special vehicles like ambulances. (Maduwanthi et al., 2016) proposed a traffic management scheme for both vehicles and pedestrians. The study was done to analyze the current traffic situation in Kottawa city and store the data for predictions. It uses the data to predict traffic congestion in the year 2034. The summary of the related works is shown in Table 2.

*Table 2. Review Summary*

Reference	Technology	Features
(Arel et al., 2010)	Reinforcement Learning	Algorithm-Based and designed for junction
(Khaled et al., n.d.)	Multi-Agent	Monitoring and detection, and traffic device control
(Pierre-Luc Gregoire et al., 2007)	Machine Learning	Learning algorithm and designed for junction congestion
(Omar, 2015)	IoT RFID	Controller-Based with designed algorithms
(Qingming et al., n.d.)	Learning Agents, Distributed system	Real-time and controller based

(C.P.Pappis ; Ebrahim H. Mamdani, n.d.) ,(Cao et al., 1999)	Fuzzy Logic, Classifier Systems	Four lanes with centre controller based.
(Mirchandani and Head, 2001)	Designed Algorithm	Chunking the traffic problem into subproblems, predict traffic flows, use optimization modules
(Blosseville et al., 1990)	Image Processing	Designed Algorithm for the intersection
(Walad and Shetty, 2014)	Image Processing	Real-time and not for the junction.
(Péter, 2012)	Mathematical Modelling	Controller base for a junction and real-time Provide advices for traffic centres
(Bull et al., 2004)	Learning classifier system	Four-way junction and real-time.
(Di Febbraro et al., 2004)	Hybrid Petri Nest	Real-Time. Give priority to special vehicles.
(Maduwanthi et al., 2016)	Analysing	Real-time system and give Predictions for both vehicles and pedestrians

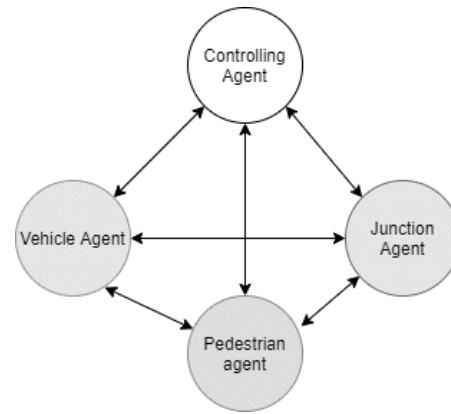

Figure 1. Experimental design for traffic control using Multi-Agent Technology

Junction Agent controls the traffic lights in each lane of the junction. The junction agent communicates with both vehicle and pedestrian agents to make the decisions. Junction Agent mainly considers the maximum waiting time of a lane in dynamic environmental situations. The vehicle agent communicates with the main agent at the intersection and it will analyze the situation.

Vehicle agents will get the priorities according to the situation. The vehicle agent also has to give a chance for the pedestrian agent. The pedestrian agent can communicate with the junction agent and may have to wait for permission to cross until other agents handle the condition efficiently. The controlling agent handles all the requirements and requests coming from the vehicle, pedestrian, and junction agent in a dynamic environment.

The study depicts the way of increasing traffic congestion and suggests some solutions like communicating with vehicles to use other roads, efficient pedestrians, and better traffic light controlling methods.

### Design of The System

Traffic controlling system has been designed with the four different types of agents namely vehicle, junction, pedestrian, and controlling agent. Figure 1 shows the agent design of the proposed system.

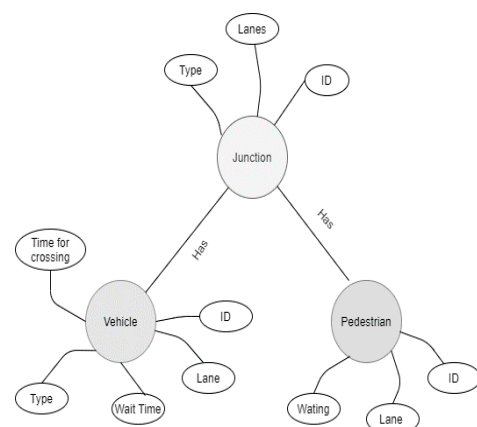

Figure 2. Ontology of the Traffic Controlling System

The ontological model of the proposed system has shown in Figure 2. In Multi-Agent technology, ontology is the main diagram that depicts detailed information of agents. It provides the metadata associated with agents and their relations.

The ontology consists of static knowledge of junction, vehicle, and pedestrian agents. This ontological data can be used to build up the knowledge base for the system. The agent communication of the proposed system has shown in Figure 3.

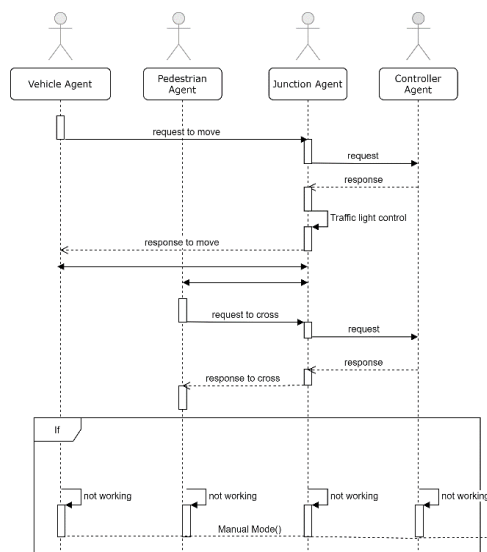

Figure 3. Communication Diagram

Agent communication in the system happens through three basic rules.

- Keep the lanes without any vehicle in disable state
- More period is allowed for lanes with more vehicle.
- Each lane comprises a maximum waiting time.

With the agent communication, controlling has been re-arranged. The vehicle agent requests the junction agent to move through the junction. The vehicle agent requests the junction agent to move through the junction. The request communicates to the controller agent and handles the scenario. The permission for moving directs to the junction agent and then to the vehicle agent. As same

the pedestrian’s request to cross the road go through the agent to the controller agent. The response to cross the road guides to the junction agent for traffic light controlling and to the pedestrian agent. If any error arises in one of the agents, the system automatically switches to the manual mode, which is the time-based method because the failure of one agent collapses the whole system.

### Working Through A Simulation Environment

With the above, concepts, as the first stage of the research, the performance of the system has been compared with other existing methods using Net Logo simulations. Figure 4 shows the simulation environment of the proposed system. With the simulation environment, performance has been calculated by comparing other approaches.

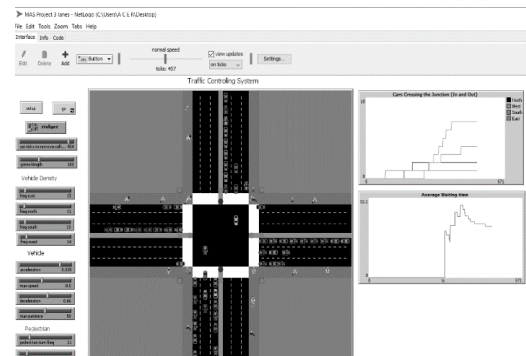

Figure 4. Netlogo Simulation Environment

In the simulation, both preprogrammed and multiagent based systems are implemented. The traffic lights in the preprogrammed system are operated into the given pattern and keep active for the given time. In Multi-agent simulation the system takes the decisions according to the previously defined rules. The lanes without any vehicles won’t get active until a vehicle appears. These situations can be simulated by changing the no of vehicles on each road. More time allocated for lanes with higher vehicle density. Some varying factors have been graphed in the simulation.

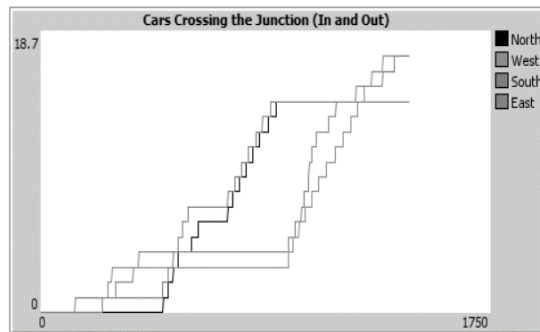

Figure 5. Graph of Vehicles crossing the junction

Figure 5 shows the density of vehicles crossing junction and goes in and out on each road. The graph values gradually increase as the vehicles come to the junction. The graphs keep in a continuous value when pedestrians crossing the roads.

### Conclusion and Further Work

According to the review, most of the traffic control systems work using fuzzy logic and reinforcement learning technologies. These systems were implemented with common functions like real-time controlling, center controller-based, with specially designed algorithms, etc. However, most of the traffic control systems don't achieve dynamic control. Especially when moving from a fixed time-based system to an autonomous intelligent system, dynamic scheduling is important to control the junctional traffic jams. Apart from fuzzy logic and reinforcement learning, technologies like image processing, learning classifier systems, IoT has been used for autonomous traffic control. When it comes to the use of Multi-Agent technology, very few systems have been implemented for traffic control. However, those systems are also mostly limited to software programs, A traffic controlling system comprises agents capable of acting independently, exhibiting control over their internal state. The environment is the interaction between the outside world and agents is determined through the environment. In a traffic control system environment is dynamic where it changes while an agent is deliberating. Ontology is the

collection of knowledge, rules, and actions. The ontology must be agreed and understood among the agent community to enable each agent to understand messages from other agents for traffic control.

The main difference in using Multi-Agent system technology for traffic control is that the system can fulfill the dynamic environmental requirements. Each lane in the junction can be monitored through this autonomous system and be able to change according to the situation. That fulfills the adaptability function. Through agent communication function the system environment can be from static to dynamic. Choosing the best agent methodology for creating a system can be a challenge. As per the study, using Multi-Agent system technology together with software and hardware solutions to traffic control could be more efficient and productive than the current time-based system.

In the next phase, we will test the system in a real-time environment by developing the hardware module. The system will implement on raspberry pi modules and image processing techniques will be used to track the vehicle density in each lane. The actual performance of the proposed system can be evaluated after implementing on real environment.

### References

- Arel, I., Liu, C., Urbanik, T., Kohls, A.G., 2010. Reinforcement learning-based multi-agent system for network traffic signal control. *IET Intell. Transp. Syst.* 4, 128–135. <https://doi.org/10.1049/iet-its.2009.0070>
- Blosseville, J.M., Krafft, C., Lenoir, F., Motyka, V., Beucher, S., 1990. TITAN: New Traffic Measurements by Image Processing. *IFAC Proc. Vol., IFAC/IFIP/IFORS Symposium on Control, Computers, Communications in Transportation*, Paris, France, 19-21 September 23, 35–42. [https://doi.org/10.1016/S1474-6670\(17\)52647-6](https://doi.org/10.1016/S1474-6670(17)52647-6)

- Bull, L., Sha'Aban, J., Tomlinson, A., Addison, J.D., Heydecker, B.G., 2004. Towards Distributed Adaptive Control for Road Traffic Junction Signals using Learning Classifier Systems, in: Bull, Larry (Ed.), Applications of Learning Classifier Systems, Studies in Fuzziness and Soft Computing. Springer, Berlin, Heidelberg, pp. 276–299. [https://doi.org/10.1007/978-3-540-39925-4\\_12](https://doi.org/10.1007/978-3-540-39925-4_12)
- C. P. Pappis; Ebrahim H. Mamdani, n.d. A Fuzzy Logic Controller for a Traffic Junction - IEEE Journals & Magazine [WWW Document]. URL <https://ieeexplore.ieee.org/abstract/document/4309605> (accessed 1.22.20)
- Cao, Y.J., Ireson, N., Bull, L., Miles, R., 1999. Design of a Traffic Junction Controller Using Classifier System and Fuzzy Logic, in Reusch, B. (Ed.), Computational Intelligence, Lecture Notes in Computer Science. Springer, Berlin, Heidelberg, pp. 342–353. [https://doi.org/10.1007/3-540-48774-3\\_40](https://doi.org/10.1007/3-540-48774-3_40)
- Di Febbraro, A., Giglio, D., Sacco, N., 2004. Urban traffic control structure based on hybrid Petri nets. IEEE Trans. Intell. Transp. Syst. 5, 224–237. <https://doi.org/10.1109/TITS.2004.838180>
- Graham Low, Quynh Tran Nhu, n.d. (1) Agent-Oriented Methodologies | Request PDF [WWW Document]. ResearchGate. URL [https://www.researchgate.net/publication/314537720\\_Agent-Oriented\\_Methodologies](https://www.researchgate.net/publication/314537720_Agent-Oriented_Methodologies) (accessed 1.22.20).
- How Do Traffic Signals Work? 2006.
- Khaled, Keshav, Hossain, n.d. An intelligent multi-agent approach for road traffic management systems - IEEE Conference Publication [WWW Document]. URL <https://ieeexplore.ieee.org/abstract/document/5280966> (accessed 1.29.20).
- M. Tomizuka, and P. Varaiya, n.d. Traffic signal timing problems with environmental and equity considerations - Li - 2014 - Journal of Advanced Transportation - Wiley Online Library [WWW Document]. URL <https://onlinelibrary.wiley.com/doi/full/10.1002/atr.1246> (accessed 1.29.20).
- Maduwanthi, C.D.S., Gunarathna, T. a. M.N., Weerasekera, K.S., 2016. A Traffic Management Scheme to ease Vehicle & Pedestrian Movements in the Kottawa Town. Eng. J. Inst. Eng. Sri Lanka 49, 35–50. <https://doi.org/10.4038/engineer.v49i2.700>
- Mirchandani, P., Head, L., 2001. A real-time traffic signal control system: architecture, algorithms, and analysis. Transp. Res. Part C Emerg. Technol. 9, 415–432. [https://doi.org/10.1016/S0968-090X\(00\)00047-4](https://doi.org/10.1016/S0968-090X(00)00047-4)
- Omar, H., 2015. Intelligent Traffic Information System Based on Integration of Internet of Things and Agent Technology. Int. J. Adv. Comput. Sci. Appl. 6. <https://doi.org/10.14569/IJACSA.2015.060206>
- Péter, T., 2012. Modeling nonlinear road traffic networks for junction control. Int. J. Appl. Math. Comput. Sci. 22, 723–732. <https://doi.org/10.2478/v10006-012-0054-1>
- Pierre-Luc Gregoire, Brahim Chaib-draa, Desjardins, Laumonier, 2007. Urban Traffic Control Based on Learning Agents - IEEE Conference Publication.
- Qingming, Zhenjiang, Feng He, n.d. Signal Controller Design for Agent-Based Traffic Control System - IEEE Conference Publication [WWW Document]. URL <https://ieeexplore.ieee.org/document/4238989> (accessed 1.29.20).
- Schrank, D., Eisele, B., Lomax, T., 2019. 2019 Urban Mobility Report 50.
- Vlassis, N., 2007. A Concise Introduction to Multiagent Systems and Distributed Artificial Intelligence. Synth. Lect. Artif. Intell. Mach. Learn. 1, 1–71. <https://doi.org/10.2200/S00091ED1V01Y200705AIM002>
- Walad, K.P., Shetty, J., 2014. Traffic Light Control System Using ImageProcessing.

### Acknowledgment

This work would not have been possible without the guidance of many people. I thank Mr. Buddhitha Hettige and Mr. Ananda Edirisooriya for the valuable support and advice. I would like to extend my appreciation to the Head of the department and lecturers of Faculty of computing,



General sir john Kotelawala Defence university for their involvement, help and encouragement

### Author Biographies



EATA Edirisuriya is a senior lecturer of the Department of Computer Engineering, Faculty of Computing, General Sir John Kotelawala Defence University.



B Hettige is Head of the Department of Computer Engineering, Faculty of Computing, General Sir John

Kotelawala Defence University. His Research interests include Multi Agent Systems, Machine Translation, Sinhala Language and Computational Grammar.



RT Wakkumbura is a Final Undergraduate of Department of Computer Engineering, Faculty of Computing, General Sir John Kotelawala Defence University. Her area of interest includes Artificial intelligence and Multi Agent system technology.

## Domain-Based Similarity Calculation Method for Calculating Document Similarity

HMLG Herath<sup>#</sup> and BTGS Kumara

*Department of Computing & Information Systems, Faculty of Applied Sciences Sabaragamuwa University of Sri Lanka*

<sup>#</sup> hmlgherath.std.appsc.sab.ac.lk

**Abstract:** Document similarity is important in different areas dealing with textual data such as knowledge management, information extraction, natural language processing, and artificial intelligence. Several methods are existing to calculate document similarity. But the results of most approaches are unsatisfactory because specific domain and contextual similarity are not taken into consideration. In this paper, a domain-based similarity calculation method to calculate document similarity is proposed by integrating context, World Wide Web (WWW), and WordNet Similarity. Context is gathered by implementing a topic modeling algorithm and generating a domain context. There are many topic modeling algorithms available and here Latent Dirichlet Allocation (LDA) is used. The World Wide Web is used to capturing the latest knowledge. The method makes it possible to get a similarity value to the words in different domains. The quality of the obtained model is compared and evaluated using human judgment to ensure the accuracy of the calculation. Results indicate the accuracy of the calculation and the proposed model can achieve the limitations of existing measures.

**Keywords:** Domain-based Similarity, Topic modeling, Wordnet Similarity, World Wide Web

### Introduction

#### A. Background

Information required by the users today become varies and users deal with textual data more than the numerical data (Niharika,

Latha and Lavanya, 2012). Since most information (more than 80%) is stored as text, it is believed that text mining has a high commercial value (Korde, 2012). It is a difficult task to apply data mining techniques to textual data instead of numerical data (Hotho, Nürnberger, and Paaß, 2005). Text mining is the mining of textual data. Text mining or text data mining is the process of obtaining high-quality information from text by analyzing and exploring unstructured text data (Potdar and Patterwar, 2016)(Aggarwal and Zhai, 2013). In the Text-Mining similarity measure plays a major role (Feldman et al., 2009).

A similarity measure is a function that calculates the degree of similarity between a pair of objects. Information acquiring, text classification, document clustering, question generation, text summarization similarity measuring is some areas that play an important role in text-similarity measuring (Agnihotri, Verma and Tripathi, 2014). When considering document similarity there are already exists plenty of techniques and tools and novel researches have been produced almost every year. In those research papers, the aim has been to explore and evaluate different techniques for similarity measures. The fundamental part of text similarity is finding the similarity between words. Then it can apply to sentences, paragraphs, and document similarities (Huang et al., 2012).

If words have a similar character sequence, they are similar lexically. This estimates the degree of similarity between the word sets of two given languages. Semantic similarity

means the likeness among text and document based on their contextual meaning (H. Goma and A. Fahmy, 2013). Determining semantic similarity between word pairs is an important component of text understanding which enables textual resources to be processed, classified, and structured (Majumder, Pakray, Gelbukh and Pinto, 2020). Ontologies, thesauri, domain corpora are several approaches used in the past, for assessing word similarity (Batet, Sánchez, and Valls, 2011). WordNet is the most popular knowledge base, which has been widely applied in many studies.

In similarity measures, it maps the distance or similarity between the symbolic descriptions of two objects into a single numeric value. It depends on two factors; properties of the two objects and the measure itself. Traditional approaches represent documents as a bag of- words and compute document similarities using measures like cosine similarity, Jaccard, Pearson Correlation Coefficient, Averaged Kullback-Leibler Divergence, and dice. From the research findings, the results of some existing approaches of calculating document similarity are unsatisfactory, as much specific semantic knowledge and contextual similarity are not taken into consideration (Agnihotri, Verma and Tripathi, 2014). And some methods are not up to date knowledge, time-consuming, and need more expert knowledge. (Feng, Wei, Lu and Dang, 2014).

#### B. Motivation

The traditional methodologies used in calculating document similarity is focused and analyzed in this study. Cosine similarity, Jaccard similarity, Dice coefficient, Pearson correlation, TF-IDF, Clustering methods like K-means, k-medoids are some methods recently used. When considering the cosine similarity, it still can't handle the semantic meaning of the text perfectly (Rahutomo, Kitasuka, and Aritsugi, 2012). Implementing cosine similarity calculation between two-

term vectors often produces syntactically inconsistent results. Syntax matching may not be able to meet the difference of the problem with semantic meaning. For further process, the information retrieval system, it may produce a false result and cause degrading in its performance (Rahutomo, Kitasuka and Aritsugi, 2012). Cosine similarity is not of up-to-date knowledge. That means if cosine similarity is implemented into a case, there exists a synonym relation or a hypernym-hyponym relation the similarity result is low (Madylova and Öğüdücü, 2009).

The most common method utilizes a lexical database as a semantic network is Wordnet (Sebti and Barfroush, 2008). The similarity between two concepts can be derived based on WordNet's exploration (Curran, 2003). WordNet glosses as a corpus of contexts one obtains about 1.4 million words, which should be processed to create the context vectors introducing a noticeable computational cost (WordNet, 2009). These measures perform poorly with some terms due to the limited coverage of specialized domains in the knowledge models (Batet, Sánchez, and Valls, 2011). They are manually created by knowledge experts, so, they represent the ideal context of a concept. WordNet does not include information about the pronunciation of words and it contains only limited information about usage. It aims to cover most of everyday English and does not include much domain-specific terminology (Kilgarrieff and Fellbaum, 2000).

#### C. Problem Statement and Research Questions

Measuring the sentence similarity is useful in various research fields, such as artificial intelligence, knowledge management, and information retrieval. Many methods are existing to measure document similarity. But the results of the most traditional approaches are unsatisfactory, as much specific semantic knowledge, contextual

similarity and domain are not taken into consideration. And some methods are not up to date knowledge, time-consuming and need more expert knowledge.

The following are the research questions relative to this research.

RQ1: How we can integrate existing methods of calculating document similarity?

RQ2: What are the trending context-based and semantic similarity methods for calculating document similarity?

RQ3: How we can capture the context?

RQ4: What are the main issues and limitations of integrating existing methods of measuring similarity?

#### D. Research Objectives and Goals

According to the study, there are many types of research in calculating document similarity that has conducted using traditional methods and also using some hybrid methods. During the systematic literature review, several gaps and shortcomings have been found in the existing researches. The objective of this work is to address those limitations by proposing a novel methodology.

##### 1) Main Objective:

Propose a domain-based similarity calculation method for calculating document similarity

##### 2) Specific objectives:

Capture the latest knowledge of the area of calculating document similarity.

Integrate the existing methods of measuring similarity.

Generating a domain context.

## Methodology

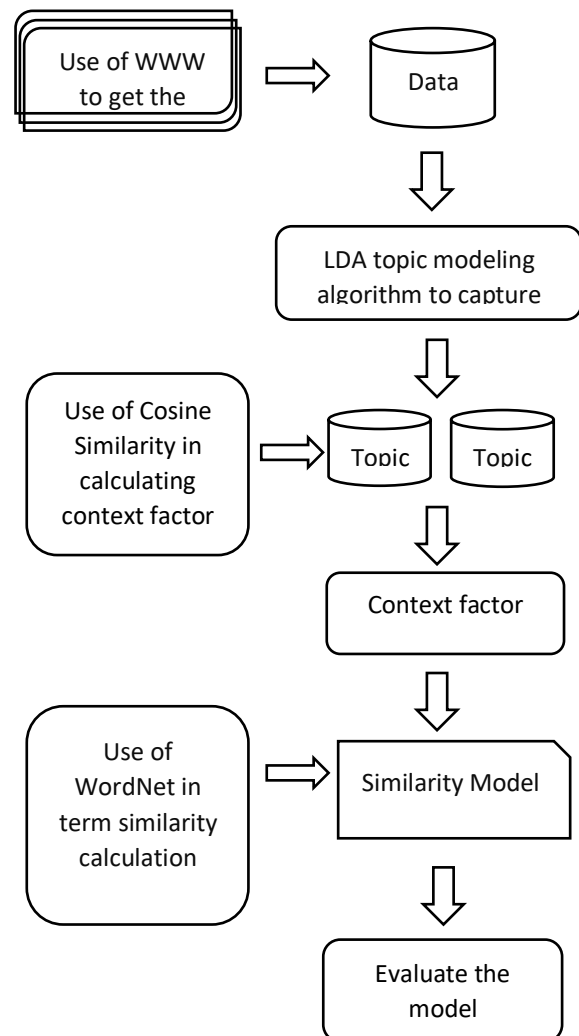

Figure 1. Methodology

#### A. Data set and Requirement analysis

Input for this research is collected using the World Wide Web. The World Wide Web is the universe of network-accessible information, a representation of human knowledge. It connected the world in a way that was not possible before and made it much easier for people to get information, share, and communicate. It provides increased capacity, greater sample diversity, easier access and convenience, lower costs, and time investment in data collection. The main intend to use WWW in here is to capture the latest knowledge captured using the WWW.

In a natural language environment, the semantic similarity of the same pair of words

may have a large difference in different areas of knowledge (Feng, Wei, Lu and Dang, 2014). As the initial step, a list of words is selected. For example, when considered the words ‘Apple’ and the ‘Computer’, apple is a fruit and a computer is a machine. It will give a less similarity value. But if we consider the two words in the technology domain, apple is a type of computer. There should be a high similarity value then. As above mentioned, a list of word pairs representing two domains is selected. Individual search results of each word and combined search results of the words have been gathered. There are unlimited search results for input in the World Wide Web. So, the amount of data captured is limited here. The data is collected manually and the collected data are saved into CSV files.

*Table 1. List of words used*

Word1	Word2	Combined Results
Apple	Computer	Apple Computer
Apple	Fruit	Apple Fruit
Blackberry	Fruit	Blackberry Fruit
Blackberry	Phone	Blackberry Phone
Bat	Animal	Bat Animal
Bat	Game	Bat Game
May	Tree	May Tree
May	Month	May Month
Orange	Color	Orange Color
Orange	Fruit	Orange Fruit
Ambulance	Vehicle	Ambulance Vehicle
Ambulance	Medical	Ambulance Medical
Minute	Time	Minute Time
Minute	Report	Minute Report
Ball	Dance	Ball Dance
Ball	Game	Ball Game
Bank	Money	Bank Money
Bank	River	Bank River
Band	Music	Band Music
Band	Hair	Band Hair
Gold	Jewelry	Gold Jewelry
Gold	Color	Gold Color

Windows	OS	Windows OS
Windows	Glass	Windows Glass
Capital	Letter	Capital Letter
Capital	Country	Capital Country
Wheel	Vehicle	Wheel Vehicle
Wheel	Tire	Wheel Tire
Ring	Bell	Ring Bell
Ring	Jewelry	Ring Jewelry
Nail	Finger	Nail Finger
Nail	Pin	Nail Pin
Palm	Tree	Palm Tree
Palm	Hand	Palm Hand
Rock	Music	Rock Music
Rock	Stone	Rock Stone
Rose	Flower	Rose Flower
Rose	Color	Rose Color
Toast	Drink	Toast Drink
Toast	Food	Toast Food

### B. Implementing the Latent Dirichlet Allocation (LDA) topic modeling algorithm

Topic modeling is an unsupervised machine learning technique that is capable of scanning a set of documents, detecting word and phrase patterns within them, and automatically clustering word groups and similar expressions that best characterize a set of documents. Latent Dirichlet Allocation (LDA) is an example of a topic model and is used to classify text in a document to a particular topic. It builds a topic per document model and words per topic model, modeled as Dirichlet distributions (Topic Modeling using Latent Dirichlet Allocation (LDA) | Honing Data Science, 2020). In this research, context is gathered with the use of LDA. Input to the LDA is the collected data from the Web. Then the topics for each input file are gathered. The LDA was applied in python using Jupyter Notebook. The process followed is mentioned below.

### 1) Loading data

Captured data from the World Wide Web is used as the input data set to LDA. Each CSV data file contains the search results for the selected words in Table 1. Then that CSV file was read.

### 2) Data cleaning

A simple preprocessing was done on the content of files to make them more amenable for analysis, and reliable results. To do that, a regular expression is used to remove punctuation, and then lowercase the text.

### 3) Exploratory analysis

To verify whether the preprocessing happened correctly, a wordcloud is made using the wordcloud package to get a visual representation of most common words. It is key to understanding the data and ensuring that whether the right track is followed, and if any more preprocessing is necessary before training the model.

### 4) Preparing data for LDA analysis

The next, step is to transform the textual data in a format that will serve as an input for the training LDA model. It is started by converting the documents into a simple vector representation (Bag of Words BOW). Next, convert a list of titles into lists of vectors, all with length equal to the vocabulary. Then plot the ten most frequent words based on the outcome of this operation (the list of document vectors). As a check, these words should also occur in the word cloud.

### 5) LDA model training and results visualization

Then the number of topic parameters need is input and visualized the results.

### C. Implementing Cosine Similarity

Cosine Similarity is a measure of similarity that can be used to compare documents and give a ranking of documents concerning a

given vector of query words. In this research, the Cosine similarity algorithm was used which is implemented in Java as the programming language and Eclipse is the IDE. In this case, input to the cosine similarity is the topics resulted from the LDA, any value between 0 and 1 is given as the output of the algorithm.

### D. Calculating WordNet Similarity

WordNet is also going to consider creating the similarity model which is an ontology-based similarity calculation method. It is a large lexical database of English. Nouns, verbs, adjectives, and adverbs are grouped into sets of cognitive synonyms or synsets, each expressing a distinct concept where synsets are interlinked through conceptual-semantic and lexical relations In the initial step of collecting data, a list of domain-based words is selected. Here, WordNet is used to compare and get the similarity of that selected pair of words.

If it is describing further, as the initial step researcher installs the WordNet software to the personal computer. After installing WordNet, an algorithm was implemented for calculating the similarity of words.

### E. Integrating Methods

The final part of the methodology is to integrate the implemented methods. There a novel equation is created as follows.

Term Similarity= Wordnet Similarity + Context factor

The gathered results of the WordNet similarity value and the Cosine similarity values are applied in the above equation and get a value for each pair.

## Results

The initial part of the research is to collect data using the World Wide Web. The selected word pairs as stated above, considering their domain are represented in Table 1. There are unlimited search results to

a word. So here search results gathered are limited, and the search results of each word and the word pairs were gathered.

Then that data set of search results were applied to the topic modeling algorithm LDA and gathered the topics of each word. Then those topics were preprocessed and calculated the cosine similarity of them.

At the same time, the WordNet similarity of the selected word pairs was calculated. In the initial part, a pair of domain-based words were selected. The WordNet similarity of that pairs is calculated here using the implemented algorithm. As a result, a value between 0 and 1 has resulted.

The next step of integrating the methods is processed using the cosine similarity results and the WordNet similarity results. There the results were applied to the following equation and calculated a term similarity value for each pair.

$$\text{Term Similarity} = \text{WordNet Similarity} + \text{Context factor}$$

After the calculation of term similarity, it was evaluated using human judgment. They were asked to give a similarity value for each pair of words. Then calculated the average similarity value for each pair of words.

The Pearson correlation was used to compute the correlation between human ratings and the term-similarity methods and calculated as:

$$r(HR, IRT) = \frac{\sum(ts_1ts_2) - \frac{\sum ts_1 \sum ts_2}{N}}{\sqrt{\prod_{i=1}^2 (\sum ts_i^2 - \frac{(\sum ts_i)^2}{N})}}$$

Here, HR is the human rating and IRT is the Information retrieval-based term-similarity method. Parameters ts1 and ts2 are the human-rating similarity and the term similarity for terms, respectively. Parameter N is the number of term pairs.

The coefficient value can range between - 1.00 and 1.00. If the coefficient value is in the negative range, then that means the relationship between the variables is negatively correlated, or as one value increases, the other decreases. If the value is in the positive range, then that means the relationship between the variables is positively correlated, or both values increase or decrease together.

*Table 2. Correlation between human rating and term-similarity methods*

Term1	Term2	Context-Aware Similarity	Human Rating	Wordnet Similarity
Apple	Computer	1	0.57	0.06
Ambulance	Vehicle	0.8	0.78	0.6
Blackberry	Fruit	1	0.73	0.3
Bat	Animal	1	0.69	0.5
May	Month	0.81	0.86	0.76
May	Tree	0.76	0.63	0.6
Minute	Time	0.99	0.85	0.89
Minute	Report	0.54	0.6	0.75
Ball	Dance	1	0.72	0.93
Bank	Money	0.68	0.85	0.85
Band	Music	1	0.81	0.68
Band	Hair	0.81	0.66	0.57
Gold	Jewelry	1	0.84	0.11
Gold	Color	0.95	0.6	0.35
Windows	OS	1	0.83	0.92
Windows	Glass	1	0.64	0.6
Capital	Letter	0.9	0.82	0.83
Wheel	Tire	1	0.68	0.67
Ring	Jewelry	1	0.84	0.83
Nail	Finger	1	0.85	0.8
Palm	Hand	0.8	0.76	0.77
Rock	Music	1	0.77	0.69
Rock	Stone	1	0.8	0.83
Rose	Flower	0.81	0.86	0.82

Toast	Food	0.76	0.81	0.66
Correlation		0.82	1	0.5

The value of 0.82 has resulted in the Correlation between human rating and context-aware similarity and the value of 0.5 has resulted in the wordnet similarity and human rating. That means there is a positive relationship between those pairs of variables. For a positive increase in one variable, there is also a positive increase in the second variable. Here, both correlations are positive values but the context-aware similarity method has the highest correlation value compare to the WordNet method. That means the strength of the relationship between context-aware similarity and human rating is higher compared to the wordnet.

### Discussion and Conclusion

In this paper, a domain-based similarity calculation method is proposed for calculating document similarity. Though there are many methods available to measure document similarity, many of them did not take into account the domain knowledge. The novel method is proposed by integrating existing methods to overcome the limitations of them. Context, World Wide Web (WWW), and Wordnet are considered here. The context is captured by implementing an LDA, a topic modeling algorithm. The World Wide Web is used to capture the latest knowledge. Methods were calculated separately and then integrated them by introducing a term similarity equation. Finally, the values were evaluated using human judgment. The experimental results (Table 2) show that the context-aware similarity method has the highest correlation value compare to the WordNet method which confirms that the relationship between the variables is positively correlated, and there is a higher relationship between context-aware similarity and human rating compared to the wordnet.

### References

- ggarwal, C. C. and Zhai, C. X. (2013) Mining text data, Mining Text Data. doi: 10.1007/978-1-4614-3223-4.
- Agnihotri, D., Verma, K. and Tripathi, P. (2014) 'Pattern and cluster mining on text data', in Proceedings - 2014 4th International Conference on Communication Systems and Network Technologies, CSNT 2014. doi: 10.1109/CSNT.2014.92.
- Batet, M., Sánchez, D. and Valls, A. (2011) 'An ontology-based measure to compute semantic similarity in biomedicine', Journal of Biomedical Informatics. doi: 10.1016/j.jbi.2010.09.002.
- Curran, J. (2003) 'From distributional to semantic similarity', University of Edimburgh. doi: 10.1.1.10.6068.
- Feldman, R. et al. (2009) 'Introduction to Text Mining', in The Text Mining Handbook. doi: 10.1017/cbo9780511546914.002.
- Feng, X., Wei, J., Lu, W. and Dang, J., 2014. Word Semantic Similarity Calculation Based on Domain Knowledge and HowNet. TELKOMNIKA Indonesian Journal of Electrical Engineering, 12(2).
- H.Gomaa, W. and A. Fahmy, A. (2013) 'A Survey of Text Similarity Approaches', International Journal of Computer Applications. doi: 10.5120/11638-7118.
- Hotho, A., Nürnberger, A. and Paaß, G. (2005) 'A Brief Survey of Text Mining', LDV Forum - GLDV Journal for Computational Linguistics and Language Technology. doi: 10.1111/j.1365-2621.1978.tb09773.x.
- Honing Data Science. 2020. Topic Modeling Using Latent Dirichlet Allocation (LDA) | Honing Data Science. [online] Available at: <<https://honingds.com/blog/topic-modeling-latent-dirichlet-allocation-lda/>>
- Huang, L. et al. (2012) 'Learning a concept-based document similarity measure', Journal of the American Society for Information Science and Technology. doi: 10.1002/asi.22689.
- Kilgarriff, A. and Fellbaum, C. (2000) 'WordNet: An Electronic Lexical Database', Language. doi: 10.2307/417141.



Korde, V. (2012) 'Text Classification and Classifiers: A Survey', International Journal of Artificial Intelligence & Applications. doi: 10.5121/ijai.2012.3208.

Madylova, A. and Öğüdücü, Ş. G. (2009) 'A taxonomy based semantic similarity of documents using the cosine measure', in 2009 24th International Symposium on Computer and Information Sciences, ISCIS 2009. doi: 10.1109/ISCIS.2009.5291865.

Majumder, G., Pakray, P., Gelbukh, A. and Pinto, D., 2020. Semantic Textual Similarity Methods, Tools, And Applications: A Survey.

Machine Learning Plus. 2020. Cosine Similarity - Understanding The Math And How It Works? (With Python). [online] Available at: <<https://www.machinelearningplus.com/nlp/cosine-similarity/>>

Medium. 2020. Topic Modeling And Latent Dirichlet Allocation (LDA) In Python. [online] Available at: <<https://towardsdatascience.com/topic-modeling-and-latent-dirichlet-allocation-in-python-9bf156893c24>>.

Niharika, S., Latha, V. S. and Lavanya, D. R. (2012) 'A survey on text categorization', International Journal of Computer Trends and Technology.

Potdar, D. S. and Pattewar, T. M. (2016) 'A novel similarity measure technique for clustering using multiple viewpoint based method', in Proceedings of the 10th International Conference on Intelligent Systems and Control, ISCO 2016. doi: 10.1109/ISCO.2016.7727007.

Rahutomo, F., Kitasuka, T. and Aritsugi, M. (2012) 'Semantic Cosine Similarity', Semantic Scholar.

Sebti, A. and Barfroush, A. A. (2008) 'A new word sense similarity measure in wordnet', in Proceedings of the International Multiconference on Computer Science and Information Technology, IMCSIT 2008. doi: 10.1109/IMCSIT.2008.4747267.

WordNet (2009) 'WordNet Domains', WordNet Affect.

## Acknowledgement

This research was supported by the Department of Computing & Information Systems, Faculty of Applied Sciences, Sabaragamuwa University of Sri Lanka.

## Author Biographies



H. M. L. G. Herath an undergraduate student in the Sabaragamuwa University of Sri Lanka and will be graduating in 2020 with a BSc special in Information Systems.



Banage T. G. S. Kumara received the Bachelor's degree in 2006 from Sabaragamuwa University of Sri Lanka. He received the master's degree in 2010 from the University of Peradeniya and Ph.D degree in 2015 from the University of Aizu, Japan. His research interests include semantic web, web data mining, web service discovery, and composition.

## Thematic Relations Based QA Generator for Sinhala

T Dissanayake<sup>1</sup> and B Hettige<sup>#2</sup>

<sup>1</sup>Information Technology Unit, Faculty of Humanities and Social Sciences University of Sri Jayewardenepura,

<sup>2</sup>Department of Computer Engineering, General Sir John Kotelawala Defence University

# budditha@kdu.ac.lk

**Abstract:** Question-Answer Generation is one of the research areas in the field of Natural Language Processing. This paper presents how the Sinhala question-answer generator operates through the thematic relation on the given input sentence. This Sinhala question generator operates on an input of a well-defined Sinhala sentence with the subject, object, and verb along with some specifically identified POS tags for the system like Nouns, Pronouns, Adjectives, Verbs and Adverbs which can make noun phrases and verb phrases from all the possible combinations. The system uses a Sinhala tokenizer, Sinhala POS tagger, Chunker, and the semantic relationship identifier with the support of the NLTK libraries. Through the syntax analysis, it can identify thematic relations for the Sinhala input sentence. Through these semantics relations, it has the ability to generate Sinhala questions and related answers through the rule-based approach. The present system has been tested with 56 sample sentences. According to the evaluation, the system shows a 93% correctness rate.

**Key Words:** Question Generation, Sinhala, Thematic Relations, Natural Language Processing

### Introduction

Natural Language Processing is the technology used to assist computers to understand the human's natural language. It is a branch of artificial intelligence that represents the interaction between computers and humans using the natural

language. Natural language processing can be used to read, decipher, understand, and make sense of the human languages in a valuable manner. In the context of education, NLP can assist teachers, students, authors, and educators for assisting in writing, analysis, and assessment procedures. Researches have been conducted on this discipline to generate smart question generation systems like ArikIturri (Intelligent question generator based on corpora and NLP techniques) (Itziar Aldabe, 2006), Intelligent factual question generation from text to generate factual WH questions (Heilman, 2011), Intelligent Question Generation using Relative pronouns and adverbs and Question generation using NLP to solve the inverse task (PayalKhullar, 2018). Natural language processing can be integrated with a large number of educational contexts. In the present scenario, teachers and any other academics would spend a lot of time manually preparing question papers, quizzes, and other related assessment materials. Similarly, students have no automated process for self-calibration. But by automating this calibre can save a lot of time on lecturers as well as students. Particularly this research can help in calibrating yourself and remove any dependencies on mentors. Thematic relations based QA generator for the Sinhala language can be used to assess students in theory-based Sinhala language subjects which can ask questions based on sentences and provide answers using sentences. The

Sinhala Language is one of the Indo Aryan family languages and it is the spoken and written language of the majority of Sri Lankans. Most of the already developed research-based methodologies are based upon English but generating a question generator from a different language is challenging because new languages would likely present new challenges for Question Generation as different languages have different syntactic constraints that form different realizations than in English. (Heilman, 2011) This paper presents thematic relations based QA generator for Sinhala which is developed to input a sentence in Sinhala and then the system extracts the thematic relations in the texts independently, analyses, and generates questions. The rest of this paper is organized as follows. Section 2 describes related works with an overview of some existing question generation systems. Then section 3 reports the Thematic relations based Sinhala Question Generator's design and implementation. Section 4 reports the results and discussion. Finally, Section 5 concludes the paper with a note on the conclusion and further works.

### Related Works

Question generation has been a task which has got slightly less attention in the research domain specially for languages like Sinhala which is the written and spoken language of Sri Lanka. Despite the language type, similar set of steps can be incorporated to generate question from an inputted text as per the Fig. 1 A tokenizer breaks a stream of text into tokens, usually by looking for whitespace (tabs, spaces, newlines). Tokenization is the process of demarcating and possibly classifying sections of a string of input characters (Anon., n.d.). The resulting tokens are then transferred on to some other form of processing. The process can be considered a sub-task of parsing input (Anon., n.d.). POS tagging is the intelligent assignment of

descriptions to the tokens. Descriptions can be called tags, which could be one of the parts of speech tags (Anon., n.d.). So POS tagging is the assignment of the appropriate part of speech tags to the tokens of a sentence.

Descriptive details (mean, standard deviation, median, mode, minimum and maximum) of mother's age, mother's BMI, newborn's birth weight and head circumference are shown in table 1. In reference to the descriptive statistics, the sample consisted of three months postpartum mothers between ages 18 to 42 years.

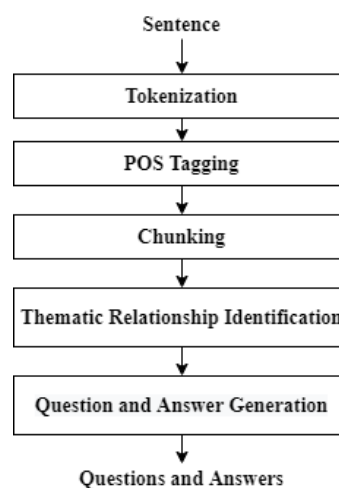

Figure 1. Question Generation process

Text chunking can also be defined as shallow parsing which follows POS tags and adds more structure to the sentence. The outcome of this is the grouping of the words in a sentence into "Chunks" (Anon., n.d.). Chunking is done using an identified chunk grammar. The thematic relations also called semantic roles of a language can be defined as various roles that a particular noun phrase play with the corresponding verb about the action or state it plays, frequently the main verb of the sentence (Anon., 2020) The concept of thematic roles has been presented to explain the syntax of a particular sentence as well as the meaning it carries. It is presented with the assumption that the pivotal factor in the formation of a sentence's meaning is the role that sentence played by

each noun phrase with the verb (Anon., n.d.). There are several approaches and methods developed and proposed for the task of question generation. The literature of the thematic relations based question generator is reviewed based on the topics Transformation based Question generation which has sub arenas like templatebased which uses matching approach of Natural Language Processing (Andrea Andrenucci, 2005), syntax-based and semantics-based which uses a syntactic tree of the inputted or given sentence to convert it to an interrogative form and logical representation of the declarative sentence to make an agglomerative sentence respectively (Michael Heilman, 2009), Ontology-based Question Generation system called OntoQue, which is an engine for objective assessment item generation based on domain ontologies which are known as knowledge representation structures which provides a conceptual model of a domain (Al-Yahya, 2011), Question generation based on Discourse Cues that can intelligently generate questions from natural language sentences using discourse connectives. with discourse connectivity, the system can be able to generate questions that look at the problem beyond the sentence level which divides question Generation into a content selection and question formation. (Manish Agarwal, 2011), Question Generation based on Dependency parses information that provides a view of a sentence provided by a parser of a given type, such as phrase structure trees or predicate-argument structure. Which presents a solution using multiple views from different parsers to create a tree structure which represents items of interest for question generation. (Anon., 2015) Topic to Question Generation and Domain-Specific concepts for Question Generation paper addresses of generating all possible questions from a preferred topic and this system considers that each topic is associated with a body of texts containing

useful information about the topic. Questions are generated by exploiting the named entity information and predicate-argument structures of the sentences present in the body of texts (Yllias Chali, 2014). Though the usage of Sinhala language is minimal in the area of researches some Natural language processing and machine learning-based systems also have been developed to a favorable extent like Ananya - A Named-EntityRecognition (NER) System for the Sinhala Language discusses data-driven techniques to detect Named Entities in Sinhala texts, with the use of Conditional Random Fields (CRF) and Maximum Entropy (ME) statistical modeling methods (S.A.P.M. Manamini, 2016). A Parser for the Sinhala Language - First Step Towards English to Sinhala Machine Translation systems comprised of a Sinhala Morphological analyzer that connects three dictionaries called the base dictionary, rule dictionary, and concept dictionary. The morphological analyzer in this system implements implication and derivations rules of the Sinhala Grammar and gives grammatical information of the words which need to be considered by the parser (B. Hettigel, 2006) Hidden Markov Model-Based Part of Speech Tagger for Sinhala Language addressed the importance of a Post tagger as it is a vital component in a natural languagerelated task which includes the analysis of the construction, behavior, and dynamics of the language which can be utilized in both the analysis of computational linguistics and automation applications (A.J.P.M.P. Jayaweera, 2014) Mahoshadha", The Sinhala Tagged Corpus-based Question Answering System addressed a novel architecture for question answering which uses basic two steps. The first one is summarizing a tagged corpus and the second one is to use the summarization to generate an answer for a query (J.A.T.K. Jayakody, 2016). Though the approaches are introduced for several tasks in question generation, developing a model

that can generate questions from a Sinhala sentence based on thematic relations which was not addressed in any of the above approaches as per the best of my knowledge.

### Design and Implementation

This chapter describes the design and implementation process of the thematic relations based on Sinhala Question Generator. The system is composed of basic modules like POS taggers, tokenizers, chunkers, and semantic relationship identifiers. The overall design of the system is composed of the basic seven processes namely Tokenization, POS Tagging, Chunking, Thematic Relation Identification, Question Generation, and Answer Generation. To perform all these processes systems have Figure 1. Question Generation process required corpus, POS tag sets, and chunk grammar as extra mechanisms. The design and implementation of the intelligent Sinhala question generator have been developed based on the following processes and modules. A. Tokenization using a tokenizer The System uses a tokenizer to split the words punctuation marks and spaces of an inputted Sinhala sentence to a list of tokens to identify each word and space in the sentence. It is developed with the default NLTK library's Sinhala corpus. To carry out the tokenizing, the system uses "word\_tokenize" from the NLTK Tokenize library. from nltk.tokenize import word\_tokenize Tokenization has performed as in the following code EXAMPLE\_TEXT = "Sample Sinhala Text." # Tokenize Defined Sentence Or Paragraph print(word\_tokenize(EXAMPLE\_TEXT))

Example: EXAMPLE\_TEXT = "ප ටොඩ්  
ලමයෝ ඇයගේ මවට පෙපමන්  
කතොකරයි."

```
print(word_tokenize(EXAMPLE_TEXT))
```

Output: ['ප ටොඩ්', 'ලමයෝ', 'ඇයගේ',  
"මවට", "පෙපමන්", "කතොකරයි", "."]

### B. POS Tagging

The Intelligent Sinhala Question generator uses a rulebased part of the speech tag system. A set of pre-defined parts of speech tags are used in the POS tag set. POS tag set is created with these POS tags specifically for this system by the author. Designed POS tag set includes Common nouns, Proper Nouns, Pronouns, Adjectives, Adverbs, and Verbs which are derived by a set of sample sentences initially used to test and develop the system. Common nouns and Proper nouns have collectively defined as Nouns in the designed POS tag set. The POS tag set is designed manually using a database table with MYSQL Libraries and SQL Queries by the author which has developed using a sample of 100 words

C. Chunking using Chunk Grammar This chunk grouping is done in the Sinhala question generation system by identifying a common chunk grammar after testing several set of chunk grammar rules to identify a common grammar which could work for all the sentences that can be made from the identified 8 patterns. Chunking is used to find phrases from a sentence like noun phrases, verb phrases, adverbial Phrases, and adjective phrases. This Intelligent Sinhala Question generation system uses Noun phrases and Verb phrases using chunk grammar to develop a parse tree. The following are the possible combinations of POS tags which can be identified as noun phrases and verb phrases according to the valid input Sinhala sentences Noun Phrase - [Noun], [Pronoun, Noun], [Pronoun], [Adjective, Noun] Verb Phrase - [Verb], [Adverb, Verb] As the sentence contains a Subject, Object, and Verb. Both Subject and Object can be considered as noun phrases. The chunking has been done using NLTK Text chunker with the use of identified chunk grammar. The system has done chunking for Noun phrasing and Verb Phrasing. The following grammar shows the finalized chunk grammar used for all

combinations For Noun phrases: NP: {||? |?}  
For Verb Phrases: VP: {|?} Overall Chunk  
Grammar: NP: {||? |?} VP: {|?} The system uses  
8 basic sentence patterns to generate  
questions as per table 1 as follows. These 8  
sentence patterns have been obtained by  
taking logical possibilities of a sentence of  
three parts (Subject, object, verb) that is 2  
3=8

Table 1. 8 basic sentence patterns

No	Subject		Object		Verb	
1	Adjective	Noun	Pronoun	Noun	Adverb	Verb
2	Adjective	Noun	Pronoun	Noun	-	Verb
3	Pronoun	Noun	-	Noun	Adverb	Verb
4	Pronoun	-	Pronoun	Noun	Adverb	Verb
5	Pronoun	Noun	-	Noun	-	Verb
6	-	Noun	Adjective	Noun	-	Verb
7	-	Noun	-	Noun	Adverb	Verb
8	-	Noun	-	Noun	-	Verb

The following sentences show examples for the 8 combinations of patterns as per the table 1

1. පොඩි ළමයෝ ඇයගේ මවට පෙනෙන්න කතාකරයි.
2. ආදර්ශවත් ගුරුතුමෝ ඔහුගේ මවට ළෙකයි
3. ඇයගේ පියෝ පොත පෙනෙන්න කියවයි
4. මම මගේ පොත පෙනෙන්න කියවයි
5. ඔහුගේ මව නිලට යයි
6. ළමයෝ සුන්දර ගම්මොනයට යයි
7. අම්මෝ කනන්දරය මිහිරිව කියයි

### 8. අම්මෝ කනන්දරය කියයි

No Subject Object Verb 1 Adjective Noun  
Pronoun Noun Adverb Verb 2 Adjective Noun  
Pronoun Noun - Verb 3 Pronoun Noun - Noun  
Adverb Verb 4 Pronoun - Pronoun Noun  
Adverb Verb 5 Pronoun Noun - Noun - Verb 6  
- Noun Adjective Noun - Verb 7 - Noun - Noun  
Adverb Verb 8 - Noun - Noun - Verb Table 1.  
8 basic sentence patterns The Following  
parse trees (Fig. 2 and Fig. 3) shows possible  
noun phrase and verb phrase combinations  
of chunks identified for some patterns as  
examples.

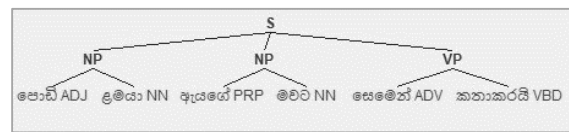

Figure 2. Chunking of the first pattern as per table 1

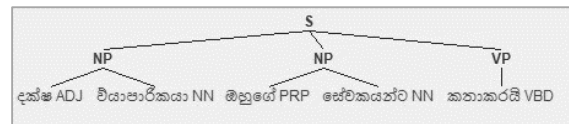

Figure 3. Chunking of the second pattern as per table 1

D. Question Generation using thematic relations  
Thematic relations based Question Generator for Sinhala uses a Semantic relationship identifier model to generate questions that were designed as a novel approach by the author to identify thematic relationships between two words in noun phrases and verb phrases. As the system generates questions based upon inputted sentences it takes sentences that have basic three parts namely subject, object, and verb. These three parts produce noun phrases and verb phrases according to the POS tags.

Thematic relations based Question Generation System's semantic relationship identifier has identified basic three formations of Noun Phrases and Verb phrases and the system has analyzed and identified common relationships for each phrase. Relationships identified for noun phrases are, noun phrases with "Pronoun" and "Noun" as first and second words always

represent the quality “අයිතිය” which denotes the ownership of the noun to the pronoun. Noun phrases with “Adjective” and “Noun” as first and second words always represent the quality “ගුණය” which denotes the qualities of the noun based on the adjective. Verb phrases with “Adverb” and “Verb” as first and second words always represent the quality “ආකාරය” which denotes the way a particular verb acts or reacts. These conclusions were derived by analyzing a sample set of noun phrases and verb phrases. The following tables (table 2 and 3 show the examples)

Table 2. Identified relationships for noun phrases

Noun	Quality	Attribute	Noun Phrase
අම්මො	අයිතිය	මම	මම අම්මො (Pronoun, Noun)
නේල	ගුණය	ජර්ධොන	ජර්ධොන නේල (Adjective, Noun)

Table 3. Identified relationships for verb phrases

Verb	Quality	Attribute	Verb Phrase
යයි	ආකාරය	පෙපමන්	පෙපමන් යයි (Adverb, Verb)

Questions have been generated using a semantic relationship identifier which was developed using MySQL and SQL Queries. Here, the noun phrases obtained from the parse tree are sent to three separate tables called NounConverter, VerbConverter, and SentencePattern. Then system writes identified Noun phrases to the NounConverter table, then noun phrase is assigned the appropriate semantic relations specified according to the rules. Identified verb phrases are also written to the Verb Converter table with the specified Semantic relationship by the system. Then the overall sentence is identified using the pre-defined pattern and written to the Sentence pattern table. Then through the identified sentence

pattern system generate a set of questions. Several questions can vary according to the number of words, various POS tags, and phrases. Answers are derived according to the created questions using the sentence patterns. The following examples show how questions are generated for the pattern one. Pattern 01 Example: ප මොඩ් ලමයො අයමේ මවට පෙපමන් කතොකරයි ([Adjective,Noun],[Pronoun,Noun],[Adverb, Verb])

Figure 4. NounConverter Table for Pattern 01

id	noun	quality	attribute
1	ලමයො	ගුණය	පොඩ්
2	මවට	අයිතිය	අයමේ

Figure 5. VerbConverter Table for Pattern 01

The following table (Table 04) represents set of questions and answers which generates based on the sentence pattern 01 as in the above example (ප මොඩ් ලමයො අයමේ මවට පෙපමන් කතොකරයි) and figure 6 shows how questions generate in the real system.

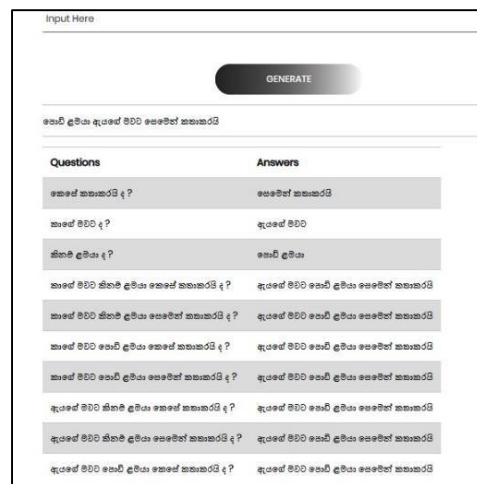

Figure 6. Screenshot of the system

Table 4. Generated Questions and Answers

Questions	Answers
පකමේ කියයි ද?	මිහිරිව කියයි
කොමේ ගුරුකුමො ද?	අපමේ ගුරුකුමො
කිනම් කතන්දරය ද?	ආදර්ශමත් කතන්දරය

කොපේ ගුරුතුමෝ කිනම් කතන්දරය පකපේ කියයි ද ?	අපේ ගුරුතුමෝ ආදර්ශවත් කතන්දරය මිහිරිව කියයි
කොපේ ගුරුතුමෝ කිනම් කතන්දරය මිහිරිව කියයි ද ?	අපේ ගුරුතුමෝ ආදර්ශවත් කතන්දරය මිහිරිව කියයි
කොපේ ගුරුතුමෝ ආදර්ශවත් කතන්දරය පකපේ කියයි ද ?	අපේ ගුරුතුමෝ ආදර්ශවත් කතන්දරය මිහිරිව කියයි
කොපේ ගුරුතුමෝ ආදර්ශවත් කතන්දරය මිහිරිව කියයි ද ?	අපේ ගුරුතුමෝ ආදර්ශවත් කතන්දරය මිහිරිව කියයි
අපේ ගුරුතුමෝ කිනම් කතන්දරය පකපේ කියයි ද ?	අපේ ගුරුතුමෝ ආදර්ශවත් කතන්දරය මිහිරිව කියයි
අපේ ගුරුතුමෝ කිනම් කතන්දරය මිහිරිව කියයි ද ?	අපේ ගුරුතුමෝ ආදර්ශවත් කතන්දරය මිහිරිව කියයි
අපේ ගුරුතුමෝ ආදර්ශවත් කතන්දරය පකපේ කියයි ද ?	අපේ ගුරුතුමෝ ආදර්ශවත් කතන්දරය මිහිරිව කියයි

### Results and Discussion

Black box testing has been conducted to test the system in the viewpoint of a user to check whether the system functions properly and provides expected outcomes concerning the execution. The finalized system of the Thematic relations based Sinhala question generation system can be performed by using a set of test cases and then these test cases have been tested by providing inputs to the system's input screen. Performance testing for the Thematic relations based Sinhala Question generator is carried out with the help of several end users with the use of a questionnaire and by giving instructions to the users to use the system in realtime to identify the quality of the questions it generates whether it has adhered to the expected requirement or not. So the final system is given to few users according to the selected sample space. The sample space for the evaluation was derived by analyzing the application of the system. Therefore, as the system can be focused a lot for the learning purposes sample space was obtained using a population of IT professionals, University Lecturers, and

University Students. So the sample space system has used 15 university students, 5 university lecturers, and 10 IT professionals which derived a performance level of 53% excellent, 30% good, 17% neutral, and 0% of bad performance. Accuracy testing was conducted by obtaining a pile of valid sample questions and checked for accuracy following the generated outcome. Therefore, it has been done using 56 sample sentences. These 56 sample sentences are created following the defined validity of the system and the sentences are being fed to the system and obtained the outcome to check whether it can generate the expected patterns of questions and answers according to the defined rule-based question patterns. Here, the system has used 56 sample sentences and from that 52 samples Sinhala sentences have been generated correctly and 4 sample Sinhala sentences have been identified as incorrect which concluded the 93% correctness rate.

Table 5. Test case sample

Sentence	Valid Parse Tree	Total QNA	Valid CNA	Invalid QNA	Final Assumption
මල්ලි වදුරන් එලවයි	T	0	0	0	T
මයිනෝ කුඩෝ පොපටන් නුවන් බැගුණි	T	5	5	0	T
අම්මෝ රු වොහිනිය මනැකමින් නරබයි	T	2	2	0	T
මෙතලයෝ මල්ලි පරොන් උරෝ පබෝයි	T	5	5	0	T
නර්තන ශිල්පිනිය වින්ර ටපේ රගෝයි	T	2	2	0	T



කුරුල්ලන් නිද සේ පියඹයි	T	0	0	0	T
මිනිසො අම්බලපම් ගිමන් රි	T	2	2	0	T
ගොයකයො සොහොන සොදර්ශන සේ ගීත ගයයි	T	5	5	0	T
දෙ රොන්රි අ සේ දිපලයි	T	2	0	2	T
නොන්නො නිවසේ ව ලය සොදයි	T	2	2	0	T

subject, object, and verb with the additional POS tags called pronouns, adjectives, adverbs. Limitations of the research have identified currently developed mechanism cannot generate questions for a sentence with 3 words that is just the basic sentence with a subject, object, and a verb. With further enhancements, more varieties of sentences can be covered with the proposed method. This project has played a foundation for various projects in Sinhala Language Question generation. Several significant areas of further works are the developed Sinhala question generator only accepts sentences with a subject, object, and verb with different other supportive POS tags as described. This system can further enhance to generate questions for complex sentences. Furthermore, it generates questions from inputted paragraphs and documentations with extensions like .doc, .pdf, .txt which can be conceded as a further enhancement of the system.

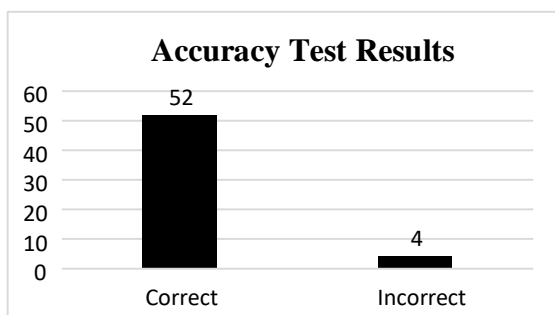

Figure 7. Test Results (Accuracy Testing)

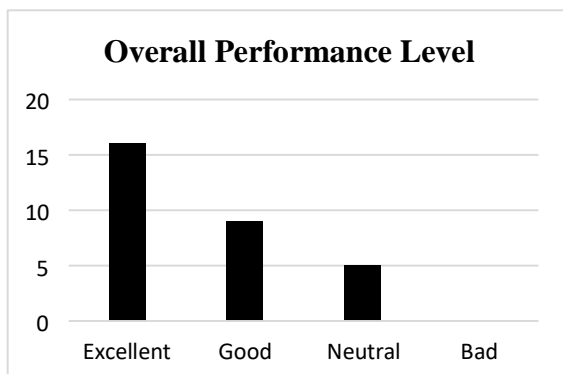

Figure 8. Test Results (Performance Testing)

### Conclusion and Further Works

Thematic relations based question generator which is developed to generate questions based on input by processing it through several stages to generate questions and answers. To achieve this system has used a semantic relationship identifier which can generate questions based on 8 identified patterns for a Sinhala sentence with the basic

### References

A.J.P.M.P. Jayaweera, N. D., 2014. HIDDEN MARKOV MODEL BASED PART OF SPEECH TAGGER FOR SINHALA LANGUAGE. International Journal on Natural Language Computing (IJNLC), 3(3), p. 15.

Al-Yahya, M., 2011. OntoQue: A Question Generation Engine for Educational Assessment Based on Domain Ontologies. s.l., s.n.

Andrea Andrenucci, E. S., 2005. Automated Question Answering: Review of the Main Approaches. s.l., s.n.

Anon., 2015. Leveraging Multiple Views of Text for Automatic Question Generation. Springer International Publishing Switzerland, p. 10.

Anon., 2020.

Wikipedia. [Online] Available at: [https://en.wikipedia.org/wiki/Thematic\\_relation](https://en.wikipedia.org/wiki/Thematic_relation) [Accessed 03 05 2020].

Anon., n.d. ello.us.de. [Online] Available at: <http://www.ello.uos.de/field.php/Semantics/SemanticsThematicrelations> [Accessed 03 05 2020].

Anon., n.d. Guru99. [Online] Available at: <https://www.guru99.com/pos-tagging-chunkingnltk.html> [Accessed 13 03 2020].

Anon., n.d. Stack Overflow. [Online] Available at: <https://stackoverflow.com/questions/380455/looking-for-a-clear-definition-of-what-a-tokenizer-parser-and-lexers-are> [Accessed 12 03 2020].

Anon., n.d. Tutorials Point. [Online] Available at: [https://www.tutorialspoint.com/natural\\_language\\_processing/natural\\_language\\_processing\\_part\\_of\\_speech\\_tagging.htm](https://www.tutorialspoint.com/natural_language_processing/natural_language_processing_part_of_speech_tagging.htm) [Accessed 12 03 2020].

B. Hettige, A. S. Karunananda, 2006. A Parser for Sinhala Language - First Step Towards English to Sinhala Machine Translation. Colombo, Sri Lanka, s.n.

Heilman, M., 2011. Automatic Factual Question Generation from Text, s.l.: s.n.

Itziar Aldabe, M. L. d. L. M. M. E. M., 2006. ArikIturri: An Automatic Question Generator Based on Corpora and NLP Techniques. Taiwan, s.n.

J.A.T.K. Jayakody, T. G. W. K. P. A. N. Y. M., 2016. "Mahoshadha", The Sinhala Tagged Corpus based Question Answering System. p. 11

Manish Agarwal, R. S. M., 2011. Automatic Question Generation using Discourse Cues. Portland, Oregon, s.n.

Michael Heilman, N. A. S., 2009. Question Generation via Overgenerating Transformations and Ranking. Language Technologies Institute School of Computer Science Carnegie Mellon University, p. 16.

PayalKhullar, K. M. M., 2018. Automatic Question Generation using Relative Pronouns and Adverbs. Melbourne, s.n.

S.A.P.M. Manamini, A. A. R. R. G. R. S. J. G. D. S. R., 2016. Ananya - A Named-Entity-Recognition (NER) System for Sinhala Language. s.l., s.n.

Yllias Chali, S. A. H., 2014. Towards Topic-to-Question Generation. Association for Computational Linguistics, 41(1), p. 20

## E-commerce model for Visually Impaired Entrepreneurs

HN Amaratunge #, and Wijendra Gunathilake

*Faculty of Computing ,General Sir John Kotelawala Defence University, Sri Lanka*

#himashaamaratunge@gmail.com

**Abstract:** According to WHO there are around 280 million people who are visually impaired and out of them 246 million are low vision people and 82% are all blind as well as most of them are women. These people getting help from someone else for their each and every purposes. When turn into their entrepreneurship they have to go for customers to sell their products with the help of someone. Sometime they face lot of adversities when they met customers. Most of customers compassion on the their career because of their disability. According to above facts, there are no any specific system which can be used to sell their products and communicate with customers directly in online platform. To accomplish this task researcher developed E-commerce system for visually impaired entrepreneurs, as android and web application using android studio, angular and firebase. This system provides an online way of solving the problems faced by entrepreneurs who are with the visual difficulties by saving their time, communication cost other difficulties and satisfaction. So, system which helps visually impaired persons to sell their products by using automated speech recognition module, with deep learning method, through that written words were translated in to spoken words. Entrepreneurship development for visually impaired person system make employees to sell their products and easier to coordinate, monitor, track and resolve customer problems and other with an effective tool. Although system mainly consist with three sections such as Visual impaired person , Customer and the

Coordinate assistant and system provide login, registration, complaint & comment and etc.

**Keywords:** Entrepreneurship, visually impaired, automated speech

### Introduction

According to (Halvorsen and Morrow-Howell, 2017) WHO there are around 280 million people are visually impaired people and out of them 36 million are colour blind. So, these people are taking help from family member or friends each and every their needs. It is very difficult for these people to when they are doing self entrepreneurship. As well as they must go for the customers to sell their products and collect their payments. Researcher developed a system to assist visually impaired entrepreneurs to sell their products and maintain appropriate communication with customers by reducing entrepreneur's time, communication cost etc. And proposed a feature to assist colour blind people to working in that system. Mainly this system contains one database with several tables such as categorized products, employees, customers etc. According to the current situation they use screen-readers for their pc's and google talk back and voice over for their phones. It provides text-to-speech information of folders, icons menus, dialog boxes and more. When apply another audio system for them is difficult to identify. So according to E-commerce system for visually impaired entrepreneur system developed online platform which is support with the keyboard. Because they mainly use keyboard for the navigate and scroll pages and there is

featured to describe button and images which is in the system.

E-commerce system for visually impaired entrepreneur system consist two separate web and android application ,one of most significant and many useful projects which developed system as well as encourage and assist customer sector and entrepreneurs can suggest possible solutions to the posted problems. The aim of this project is to develop an online entrepreneurship development for visually impaired entrepreneurs to sell their products as well as increasing their living standard who are neglected in the society by providing economic benefit to the country. Following shows the objectives,

- Planning the project in detail.
- Identify features of visually impaired e-commerce system.
- Design & Develop system with identify features.
- Review appropriate technologies and audio availability.
- Conduct testing,evaluation and improve the system to meet all requirements identified.

### **Literature Review**

Out of previous work related to Entrepreneurship with disable people paper done by c(Vaziri, D., Schreiber, D., Wieching, R. and Wulf, 2014)onsider technologies with individual person perspective, an information society perspective and business organizational perspective. So according to that paper technology supports an individual to efficiently manage all three perspectives to become self-employed. . And, Vaziri, D., Schreiber, D., Wieching, R. and Wulf. V illustrate that the current IT-accessibility is insufficient and thereby does not support the inclusion of people with disabilities. And people who with disability they use technologies in different ways such as blind people can use brail keyboards or touch

screens to scan digital screens. Mainly in this paper highlight key points regarding barriers for disable people in self-employment, such as business resources, general conditions, organizational structures and customer relationship.

(Raja, 2016)Deepti Saman Raja proposed way to understand opportunities presented by the internet and ICT for the full participation of person with disabilities. This paper reviews the main challenges to the realization of ICT-enabled inclusive development and presents cost-beneficial policy and practice recommendations for governments and development practitioners. And, that paper provide an important opportunity to break the traditional barriers of communication and interaction that persons with disabilities face and which hinder their full participation in society. A recent survey of 150 experts from over 55 countries ranked websites and mobile devices and services as the technologies that can contribute the most to the social and economic inclusion of persons with disabilities.

(Hussain et al., 2016) Sarwat Iqbal, Adnan Nadeem and Muhammad Sarim have done research on , this paper proposed a model based on the Nonaka Knowledge Spiral model to support business managers to capture knowledge about disabled person's online shopping behaviours supplement this knowledge into their website to support disabled persons. This also helps business managers to capture the un-attended population in their business net. Under that paper they mainly consider,

1)Disability, e-commerce and knowledge management:

(Alaedini, 2004)They have identified disabled persons face barriers in accessing services due to physical infrastructure and non-adoption of specialized ways proposed for them. Disabled and elder persons face

problems in shopping, and they need an environment that helps them to enable in carrying out shopping. Physical infrastructure of shopping store, proper signage, guiding ways, and cooperative sales persons are important factors that create the environment of shopping store. An enabled environment is the accessible environment that enables persons with disability to experience the shopping easily. E-retailing (online shopping) has emerged as an enabled environment for most of disabled and elder persons. They can browse the items, compare prices online with other e-retailers, pay online and enjoy home delivery option with little or no cost. They feel full control in making decisions and perform shopping related task full control thus shopping becomes a joyful experience for them.

(Chandra, 2018)U. S. S. Perera and D. N. Balasuriya mainly research on currency note recognizer which are used by the visual impaired persons. According to Sri Lanka until today they use traditional techniques for financial transactions. Only one feature available for visually impaired people to identify the denomination of various banknotes which is a series of embossed dots, which can be sensed by touch. In Sri Lanka, one currency note recognition device has been designed and implemented as a final year undergraduate project and this system employs a light dependent resistor array located at various points over the bank note's area.

(Sohaib and Kang, 2017)Osama Sohaib and Kyeong Kang they proposed an e-commerce website is the central way an e-retailer communicates with their online consumers, and online shopping websites need to be accessible to all consumers of all ages, including those with disabilities. The inability to shop online because of such interfaces increases web inaccessibility of e-commerce websites for people with disabilities.

(Mohadikar and Nawkhare, 2017) Kunal Mohadikar and Rahul Nawkhare they developed to assist visual impaired persons that automatically recognizing clothing patterns and colours. It is camera- based clothing pattern recognition is a problematic due to many clothing patterns and corresponding large intra class variations. And, according to existing texture analysis methods focus on textures with variations in viewpoint and scaling and level of accuracy in clothing pattern recognition cannot achieve by texture analysis methods. Here they introduce a system a system to assist colour blind people to select different clothing colours along with different categories.Previous work is shown in table 1.

#### A.Summary

Here is the summary of the previous works. According to that most are web applications. When considering the following table can identify main drawback as language difficulty in screen reader. So proposed system will reduce this drawback. It will discuss in methodology chapter .

#### B.Questionnaire

Used questioner to identify what are the factors more effective for Entrepreneurship development for visual impaired entrepreneurs' problem. Have made a questionnaire distributed to 20 responds and collect the views and get the average calculation of the parameters. According to that take all the literature reviews and questionnaire have gathered what is the weight of that factors and how those factors influence to my case and in the above table it describes the final output of sample survey. It consists with 8 questions and percentage weight of each output. 90.5% responds response for first question. It is the main turning point for develop the system. This technique not based on the modern googled form mode questionnaire, because these special need community can not access the

google form mode. They only can access document-based things. So according to situation used word document to gather requirements. In questionnaires developer concern to avoid asking lengthy questions and it generally focused on close ended questions. Following table shows the summary of questionnaire,

Table 2. Questionnaire Evaluation

Factor	Questionnaire weight	Answers weight	Final weight
Does disability is disturbance for doing entrepreneurship?	Yes	77.8%	77.8%
	No	11.1%	
	It depends on the attitude	10%	
How is acceptance from the market?	Good	66.7%	66.7%
	Bad	33.3%	
Do you have good relationship with customers when communicate with them?	Yes	66.7%	66.7%
	No	33.7%	
Can solve those problems using technology?	Yes	66.7%	66.7%
	No	11.1%	
	Other	22.2%	
What is the preferred way for visually impaired entrepreneurs to use this system?	Screen reader	66.7%	66.7%
	Brail system	11.1%	
	Touch screen	10%	
	Other		
Have face difficulties with screen reader?	Yes	75%	85%
	No	12.5%	

	Language difficulties	85%	
Is proposed system useful for visually impaired entrepreneurs to sell their products?	Yes	90.5%	90.5%
	No	22.2%	
	Other	5%	
Do you have problems regarding payments?	Yes	75%	75%
	No	25%	

## Methodology

### A. System Overview

Proposed system was e commerce based online platform for visually impaired entrepreneurs to sell their products using speech recognition. System is the one of the most significant and many useful projects in which proposed system the entrepreneurs should not go for the customers to sell their products and users can get their problems solved through the system. The main aim of this objective based application is to enable the handicapped specially visually impaired persons to access the ecommerce-based platform which are most widely used for online selling of items or products nowadays. So, proposed system will develop an ecommerce based application using speech recognition to eliminates or reduces the various practical difficulties that the visually impaired persons come across. In ECSFE using speech recognition for login registration and other rest parts of the system and keyboard provide an extra advantage to visually impaired entrepreneur and allows them to use the application with more flexibility.

In proposed system provides facilities as follows,

- Registration is provided for both customers and employees. Mainly visually impaired persons navigate through system by using the audio technology.

- Complete information of employees with their name, product name, price, phone number, mail (if them have) and address.
- Products are categorized according to different sections. (ex-foods, clothes).
- Users can post comments and complaints.
- Users can request products from employees according to their choice.
- Users can request transport if they want (provide online location of employees).
- Employees Have facility to communicate with bank consultant regarding payment issues.
- Flexibility in the system according changing environment.
- Controlling redundancy in posting the same data multiple times.
- Provide orders with the constraint time.
- Notification will send to the employees when they have orders, messages, comments and other.
- Training feature available for new entrepreneurs to learn how to become self-entrepreneur.

### Design

This section will give an inclusive idea about how the proposed system will be developed using analyzed client`s requirements. This section is mainly focused on requirements techniques and requirement analysis which includes a brief idea of the visual impaired entrepreneur`s self entrepreneurship. And also about the existing manual process, available systems for entrepreneurship in Sri Lanka, gathered requirements, the techniques that were used to gather relevant information and how analyzed in different viewpoints such as functional, nonfunctional, usability requirements as well as technical requirements. The section elaborates how the gathered requirements will be applied and how the existing problem will be solved

with the use of newest technologies available in the proposed E-commerce system for visually impaired persons. This document is describing about all the modules to be developed in the proposed system.

Visually impaired entrepreneurs used this system to sell their products as well as through that they can communicate with customers directly. They can used web or android application to log or register to system independently by using the audio technology and each information will inform by using notification to employees, when they receive order as well as customers want to chat with them it will inform by using that notification using audio technology. And, they can contact responsible agent(admin) for their task. Then agent will do the requested task for that entrepreneur. And updated all related tasks in the system and failures. and inform entrepreneur regarding complains, comments, orders and other. Entrepreneurs are responsible to provide requested products according to the rules. And, response to the customer complains according to the rules and analysis actions and causes to get results. After that, come up with a satisfying solution for the complainer problem. If this solution is satisfactory for then the statement of the complaint is closed. So, entrepreneurship development system is needed to improve these workflows. Here is the diagram which shows how the system will work, shown in figure 2.

#### A. System architecture

Presentation layer – The presentation layer is where the user accesses the application. The interaction of the user with the system occurs at the very moment the user gets the access to the application. This layer holds the interfaces which satisfy the requirements of each user type. As shown above in the figure, there are different user levels in system. The user levels in the system are Visual impaired entrepreneur, customer and coordinate assistant. The presentation layer provides

access to the relevant user interfaces according to their authorization.

**Business logic layer** – There are two main applications in proposed system’s business layer. They are the web application and android application. it contains the core of the system. Both application for both sides and web application mainly maintain and operate by coordinate assistant. And other main thing is with the support of API Web application and Android application connect in this layer to the Database layer. API is the most valuable part in proposed system because two application different languages connect with the API .

**Data access layer** – This layer is responsible for managing the database requirements of the system. Database layer constitutes database components as firebase database. firebase database will store the data which inserts to the system by the two main applications after the manipulation of the business layer.

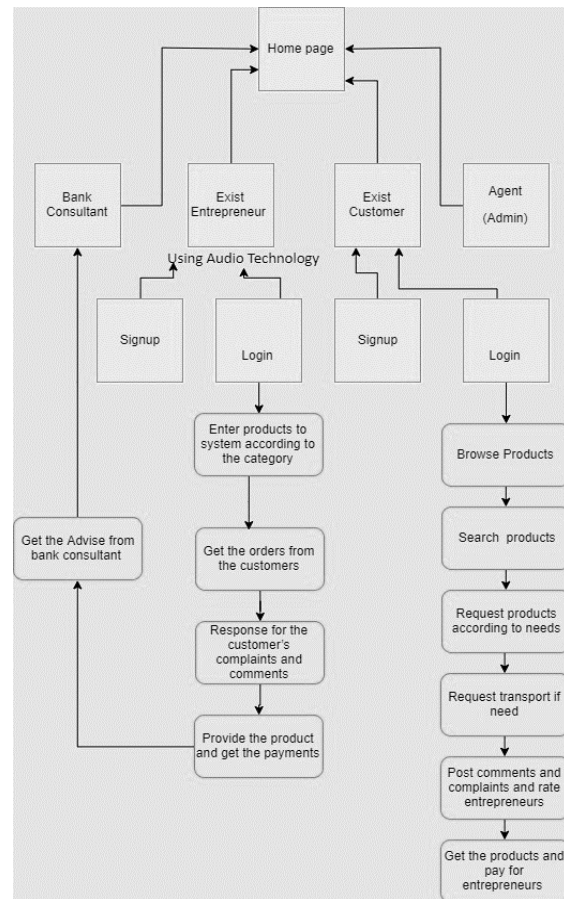

Figure 3 System Process Module

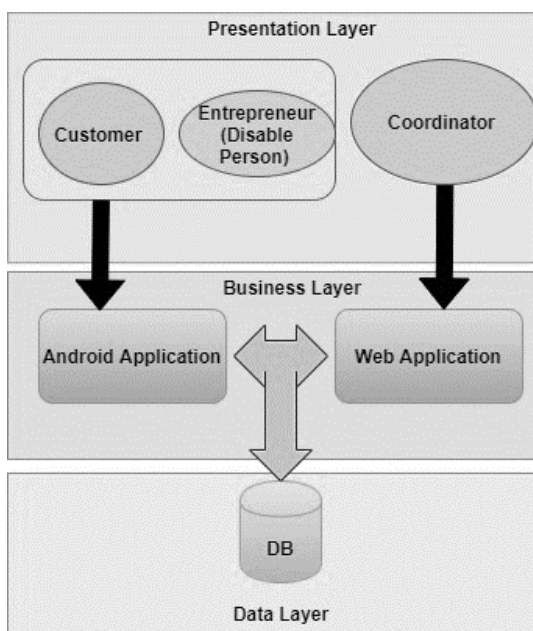

Figure 4: System architecture

### Conclusion and Limitations

The researcher has highlighted what are the existing system, failures in existing situation and how is the new system, how the system works, who are the main users, services and how they can deal with the proposed system. And, this paper gives an overview of the system architecture and implementation of the E-commerce system of visual impaired entrepreneur system as android and web based. Entrepreneur is the valuable resource in the organization they mainly inspire successful social development through of those entrepreneurs visually impaired resource is special and important to provide great service and product to customers. To meet the new challenges and requirements of the market, the business owners need to think and make better decisions. Develop a system for visual impaired persons to sell their products online. The system accept speech convert it into text format and display



the desire result. This will help visually impaired person to lead an independent life. According to this research typical deep learning algorithms have been implemented for speech recognition, Global, local feature are used for identification and multilevel clustering is used to increase the accuracy of system.

This study has limitations online accessibility evaluation tools and expert evaluation may report diverse web accessibility errors. And there is language difficulty with language and screen reader. And also visually impaired persons can't access dynamic web pages. Further enhancements are suggested to Provide a skip links option to let a user skip repetitive content and Design for device independence. As well as Use simple language on your website, and specify the language used. Suggest thinking about toning down the flashiness of your site in terms of graphics, as well as opting for a simplified and minimalist design.

## References

- Alaedini, P. (2004) Training and Employment of People with Disabilities: Iran 2003.
- Chandra, Y. (2018) 'Social Enterprise for the Visually Impaired : Voices from Within Running head: The Voices of Social Enterprise ' s Beneficiaries Social Enterprise for the Visually Impaired: Voices from Within Dr . Yanto CHANDRA ( 蔡振榮 ), Department of Public Policy , Ci', (January 2017).
- Halvorsen, C. J. and Morrow-Howell, N. (2017) 'A conceptual framework on self-employment in later life: Toward a research agenda', *Work, Aging and Retirement*, 3(4), pp. 313–324. doi: 10.1093/workar/waw031.
- Hussain, M. et al. (2016) 'Assisting Disabled Persons in Online Shopping: A Knowledge- Based Process Model', *Journal of Basic & Applied Sciences*, 12(January), pp. 23–31. doi: 10.6000/1927-5129.2016.12.04.
- Mohadikar, K. and Nawkhare, R. (2017) 'Ecommerce Based Online Shopping for Visually Impaired People Using Speech Recognition', *International Journal of Development Research*, 07(08), pp. 14581–14584.
- Raja, D. S. (2016) 'Bridging the disability divide through digital technologies', *World Development Report*, pp. 1–37. Available at: <http://pubdocs.worldbank.org/pubdocs/publicdoc/2016/4/123481461249337484/WDR16-BP-Bridging-the-Disability-Divide-through-Digital-Technology-RAJA.pdf>.
- Sohaib, O. and Kang, K. (2017) 'E-commerce web accessibility for people with disabilities', *Lecture Notes in Information Systems and Organisation*, 22(September), pp. 87–100. doi: 10.1007/978-3-319-52593-8\_6.
- Vaziri, D., Schreiber, D., Wieching, R. and Wulf, V. (2014) 'Disabled entrepreneurship and self-employment: The role of technology and policy building', p. 24.

## Acknowledgment

I would like to specially, thank and Manique Gunarathne who is the manager of special training & disability resource centre as well as Major RMM Pradeep of faculty of computing and KDU, for their valuable and precious time, which is generously and highly admired.

## Author Biographies



Himasha Navodani Amaratunge is undergraduate in BSc.(Hons) in Information Technology in General Sir John Kotelawala

Defence University , Sri Lanka. She is currently final year student in the Faculty of Computing, Department of Information Technology.



Mrs. Wijendra Gunathilake is senior lecturer in General Sir John Kotelawala Defence University , Sri Lanka under computer science department. Her most preferred research areas are, knowledge management, software engineering, e-learning, health informatics and IT strategy.

## eRemote: A Remote File Downloader for Low-Speed Network

HMGKC Bandara and B Hettige<sup>#</sup>

*Department of Computer Science, Faculty of Computing*

<sup>#</sup> budditha@kdu.ac.lk

**Abstract:** Downloading is generally copy data from one computer to another computer over the internet. A download manager is a software or hardware tool that is used to manage downloading files on computer devices from the internet. When it comes to downloading large-sized files, many mechanisms have been invented so far to accomplish the downloading task. A hardware-level device equipped with Raspberry Pi zero module, that can be remotely controlled through an android mobile application capable of downloading large scale files to local storage from any network at any time frame. Thus, a remote file download manager named eRemote has been developed to download files as an offline downloader. This device has been tested in a different network including wired and wireless networks, has shown efficacious results. This paper presents the design and implementation details of the remote downloader and offers a comparative study on existing downloaders.

**Keywords:** Remote, Downloading, File downloader, Remote file downloader

### **Introduction:**

Nowadays people always do their work with laptops, smartphones, or various electronic devices. In this digital age where information is shared between communities and countries in a matter of seconds, downloading of information has become a normal part of people's lives. People tend to download various kinds of information to their devices to complete day-to-day tasks. It may be downloading an official document from the company or simply downloading and watching a funny video sent on

WhatsApp by your friend. Hence, downloading information has become the main channel of sharing information between people.

According to statistics, most people download more than one file per day (Mushroor et al., 2019) including software, audio, video etc. But when it comes to downloading large files such as games, software, archives, etc., it takes a considerable amount of time as well as a huge data/network usage. When downloading large-sized files, it is required to keep the devices active throughout the process or else the process will be paused or stopped. Also, a common side effect of downloading files include draining the device's their battery life during the process and hence require keeping the device plugged in during file downloading procedure. To address these problems, a system could be introduced where the downloading process takes place in a different device and the device that is in use will not be affected.

The traditional way of downloading files causes extreme consumption of resources such as time, data usage and device battery. Hence, it is difficult to download large files and to keep using the device at the same time. Also, no mechanism has been introduced to allow users to download files using a remote or separate network connection.

As a solution to the above-defined problem, a remote file download device can be built using raspberry pi that could be controlled using an android application through firebase. This system will be able to take the load off the electronic device that is in use by

the user, saving time and device resources. Also, this system could be used in separate networks.

The main aim of the system is to provide a mechanism or method for users to download files over a network they are not physically present at. Hence, allowing the user to remotely control the download and save resources of the device that is being in-use by the user.

The main objectives that are expected of the system are mentioned below.

1. Downloading files.
2. Providing download links through a mobile application
3. Providing real-time status of files that are being downloaded
4. Ability to perform basic control functionalities through the mobile application

The system will function when in a separate network as well in low traffic networks and can be accessible at any time.

Technologies that are currently in-use for downloading, sharing files and remotely accessing, which will be further discussed, include torrent downloading, internet download manager, AnyDesk and TeamViewer. Each of these concepts has unique characteristics which aid in downloading, sharing files or remotely accessing a device to share and download files. But an issue seen through all these systems is that they have no mechanism to use a remote network to download files while physically existing in a different place.

The rest of the paper is organized as follows; through the section 2 of the paper, and insight will be provided about existing technologies related to downloading, sharing files, as well as existing technologies and software that allow remote accessing devices. Further section 3 of the paper will

elaborate a solution system that will overcome the defined problem. Section 4 elaborates on how the proposed system works along with user response to the proposed system. Finally, section 5 concludes the paper with a note on further improvements.

### **Related Works**

The download means accessing data and copying them to your device from a remote device over a computer network, usually servers such as web servers, FTP (File Transfer Protocol) server, email server, or some other related system. It compares with the upload, where data is sent to a remote server. A copy is a file which has been downloaded and it is also a method of downloading such a file. When it comes to downloading files and remotely controlling devices, some many mechanisms and applications have been invented so far to accomplish this task. Such as Torrent downloading, Internet download manager, AnyDesk and TeamViewer. Each of these systems will be reviewed to understand their unique functionalities and differences.

#### **A. Torrent Downloading**

A normal download is generally a direct download where downloading files is done via the browser or a download client. The concept of torrent downloading is a similar process to normal download, but the file is downloaded via a torrent client. In the tech world, when you hear the word “torrenting” it typically refers to a file downloading concept that uses a peer-to-peer protocol named BitTorrent to download files in a distributed manner. BitTorrent protocol joins the device as a part of the swarm (Han et al., 2010) (a group of devices uploading and downloading the same torrent simultaneously) and when a user needs to download a file via torrent, the user is first required to download the torrent file of the respective file that is needed to be

downloaded. Usually, a torrent file comes with the .torrent extension and it does not contain the actual material to be distributed. The .torrent file is a database file that contains metadata and list of network locations of trackers (“How Does BitTorrent Work?,” n.d.) which will be used to join a swarm of that specific torrent file through a BitTorrent client such as uTorrent, BitTorrent. Once the torrent file is entered into the BitTorrent client, the client contacts the list of trackers stored in the .torrent file. The tracker shares the IP address of the device with the rest of the swarm allowing them to connect. Once connected, the download of the actual file begins. The required file is extracted from the Seeders that are connected to the swarm, which makes this a useful concept in keeping the load off the central server (“How Does BitTorrent Work?” n.d.).

Torrent downloading is advantageous as a large group of devices can download the same file without putting too much load on the central server. Hence, less time consuming as it avoids traffic to access and download files from the central server (February 5 and Reply, 2016).

Torrent downloading has few drawbacks being a distributed download system. Since tracker shares the user IP address to all devices in the swarm, all peers will be able to see your IP address, hence, exposes the device to many risks. Lots of production and record companies are recruiting people to go in and track all of these IP addresses hence, discover uploading torrents so they can be passed on to ISPs (“Torrent: Disadvantages and Controversies - DotNet Guide,” n.d.). However, connecting to a virtual private network (VPN) will allow to change the device IP address when downloading torrents and keep the device anonymous. This is a vital resource to use when downloading torrents to keep your ISP from understanding what is being done.

## B. Internet Download Manager

Internet Download Manager (IDM) is a tool for download management and scheduling (“Internet Download Manager Features: reliability, high speed, and 24h support,” n.d.). The main advantage of this application is that the maximum bandwidth of the network can be utilized using this application. Basic features include, recovery and restart capability due to dropped link, network problems, and power outages to restore the disrupted downloads (Soffar, 2016a).

Internet Download Manager uses simple Graphical User Interface (GUI) such that it is simple and easy to use. Also, the application uses concepts such as smart download logic accelerator that features smart dynamic file segmentation and secure multipart download technology to speed up the download of files (“10+ Ways to Get the Best from Internet Download Manager,” 2015). Internet download manager facilitates the collection of proxy servers, FTP and HTTP (Hypertext Transfer Protocol) protocols, firewalls, redirects, cookies, permissions, audio and video content. Other features of the application include multilingual support, zip preview, download categories, sounds on different events, HTTPS support, HTML aid and tutorial, enhanced download virus security, progressive download with quotas (This feature is useful for connections that use some kind of equal access policy or FAP such as Direct PC or Direcway etc.), accelerator built-in etc.

IDM is mostly known for effortlessly integrating with Microsoft internet explorer, Netscape, MSN Explorer, Opera, Mozilla, Mozilla Firefox, Avant browser and any other common browsers to manage your downloads automatically. Usage of this application is simple as dragging and dropping files or using the command-line Internet Download Manager. As IDM allows scheduling downloads, users can dial the

modem at the specified time, download the files that are required, stop or shut down your computer when it is completed (“How Internet Download Manager (IDM) works? Interesting facts you may not know about best download manager - Cyber Programmers - Learn Programming,” n.d.). When downloading a file, IDM divides the files into pieces and transfers them to the device/computer simultaneously. The downloaded pieces are temporarily stored in file format on the hard disk, then merged to carry back the original file that was downloaded.

As its extensive features, IDM has its share of drawbacks such as integration failures between browsers, lack of support and a chunky interface (“Will Internet Download Manager Work For You?” 2016). Malware programmers or cybercriminals exploit the IDM program files to trick users into downloading malware into their devices. IDMan.exe is usually the operation file of IDM that is being corrupted such that when called, it may destroy the software and hardware of the computer (“How to Remove the IDMan.exe Virus? | IDMan.exe Malware,” n.d.).

#### C. AnyDesk

AnyDesk is an independent software platform that allows remote access, file transfer and VPN functionality to devices running the host application (“AnyDesk | Your Remote Desktop Application for Windows 10,” n.d.). This software operates on multiple platforms such as Windows, Linux, MacOS, iOS, Android, etc. Although this application works on a variety of platforms, an independent version of the software needs to be installed on the devices that the files are being transferred or shared to.

The user is required to provide the relevant username and password of that specific device to access the remote device. After accessing the remote device, the user can

operate the remote device without being physically present near that device. However, AnyDesk application cannot be considered as a secure platform as any user can install the application to a certain device and remotely access the data and information stored in that device without authorized permission. Also, AnyDesk application allows administrative authorities of the remote device and many incidents had been reported due to the misuse of this feature including mobile access frauds (“RBI AnyDesk Warning: Fraudsters can use this app to steal money from your bank account, stay safe | Zee Business,” n.d.), bundling ransomware (“Legitimate Application AnyDesk Bundled with New Ransomware Variant - TrendLabs Security Intelligence Blog,” n.d.), technical support scams (“As social engineering activities increase buyer beware of tech support scams | Verizon Insights Lab,” n.d.), etc.

#### D. TeamViewer

TeamViewer is a proprietary software application that supports remote device control, desktop sharing, web conferencing and file sharing between computers (“TeamViewer – The Remote Connectivity Software,” n.d.). This application also supports a wide range of platforms such as Windows (“TeamViewer V4 desktop collaboration app now Mac-compatible | Macworld,” n.d.), Linux, ChromeOS, iOS, Android, etc.

TeamViewer remote control set-up (“How to Use TeamViewer,” n.d.) this independent software operates based on temporary passwords. And to establish a connection between the two devices, a different user should authenticate the access request of the remote device. If the connection request is not accepted, the device cannot be accessed remotely. Main uses of this application include connecting multiple workstations

together which are not physically placed at the same location and file transferring between connected parties (Soffar, 2016b). However, though it is powerful software, the data usage for connecting devices together is high. The remote device will require as much data as the accessing device. Also, a user is needed to accept the connection request at the remote device if not, the device cannot be controlled or accessed remotely.

A survey was conducted to acquire information about the current download systems that are being commonly used. 11 users were selected at random, who download various types of files over the internet daily.

The users were initially asked about their experience on existing download methods they commonly use.

When asked about the most used platform to download files, it was identified that torrent downloading is the most commonly used method of downloading (36.4%). An equal amount of people out of 11 uses Internet download manager and direct website downloads (27.3%) to accomplish their day-to-day tasks. It was also discovered that 4 out of 11 users agree that the current methodology of downloading which is being used satisfied their requirements (Ref. Table 1).

54.5% of users (6 out of 11) (Ref. Table 1) agree when downloading large files, commonly used downloading applications acquire a long time to complete the download. This proves that the existing file downloading mechanisms consume time.

Thus, according to the survey, it was concluded through these technologies exist and aids file-sharing or downloading, people are quite not satisfied with its functionality. Also, it was evident through research and survey that downloading large files through these platforms consumes a lot of time.

*Table 1 - Questionnaire results*

Question	Agree	Neutral	Disagree
Satisfied with available file downloading platforms?	36.4%	36.4%	27.3%
A lot of time spent on downloading large files through those platforms?	54.5%	45.5%	0%

A common feature seen through all these applications and mechanisms is that they do not allow file download through a separate network. Files could be shared among the remote device or the device in-use could download the file using those applications. Applications such as TeamViewer and AnyDesk (as mentioned above) requires a different user to be present, operating the remote device and should accept the connection request to access the device. Even if the access was granted, sharing the file with the remote device would require both data usage and resource usage of both the devices connected. Applications such as torrent downloading, and internet download manager directly use resources of the device that is in use and cannot remotely download using a different network than what the device in-use is connected to. Hence, after reviewing existing technologies related to file downloading, the proposed system was designed and developed.

### **Design & Implementation**

Addressing the main problem, which is the inability to download files without physically being present; and reviewing the current technologies, the proposed solution is a remote file download system (eRemote). Figure 1 depicts the basic process of the eRemote File Downloading System.

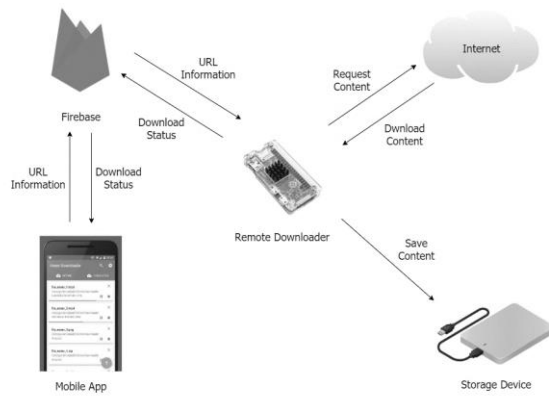

Figure 1 – System Architecture

Main components used in the construction of this system are the Raspberry Pi module as the main device and Firebase as the database connector between the Android application and the device. A mobile application is built using Android Studio as a base platform to operate the system. This mobile application can be considered as the “user-interface” (Ref. figure 2) of the system and hence used to interact with the system. To capture changes in the device and to keep the device synchronized with the mobile application, Firebase platform is used.

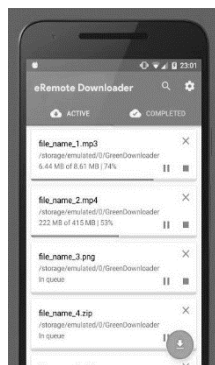

Figure 2 – The user interface of the system

The user interface of the system (Ref. figure 2) is designed in a straightforward and user-friendly manner. Using this, the user can manage the device. User can add download URL, resume, pause, stop, restart, or delete a download using the application.

To understand the system purpose in-depth, the main functionalities of the system are listed below.

### A. Process of Downloading files

The URL link provided by the user is forwarded to the device through a Firebase platform. The device that is placed in a remote location to the user, will access this URL and identify the file that is to be downloaded through the URL link. Since the device is connected to a network, it will begin downloading the file and storing the file in an external storage device that is connected to the system.

### B. URL managing module

The user is required to provide a URL link to the mobile application to download a specific file. The interface of the mobile application will allow the user to paste a URL link. Once the user enters the URL link to the system, the request will be forwarded to the Firebase database system. This device can be used to download documents, media file, archived files, etc.

### C. Real-time status Module

Firestore database system captures real-time changes that occur in applications, hence when a specific file is being downloaded from the device, the real-time status of the download can be viewed in the mobile application through Firebase. The user will have the ability to view the downloading status of the file from a remote location via the mobile application.

### D. Main Control Module

The user will be given privileges to remotely control the device and the files that are being downloaded. The user can resume, pause, stop, restart, or delete a file that is being downloaded through the device. User can also schedule downloads and download files at a predefined time through the mobile application.

The device can be placed in a different location connected to a network and be accessed through a mobile application remotely. The system can connect to the

network via Wi-Fi or Ethernet cable (using ethernet adapter). This can be considered as a major advantage as the user is not required to be present at the location and connected to the specific network to download the file. Hence, the user's in-use device resources will not be drained. This system is ideally useful in a scenario where downloading a company-related file on off-peak hours to preserve peak time internet resources of the company. Hence, due to downloading files during off-peak hours ensures low network traffic, the speed of the download will be increased, and files would not be corrupted after completing the download process.

Raspberry Pi module is considered as the downloading device of the system. The module chosen for this set-up is Raspberry Pi Zero W module. This module consists of a both wired (using ethernet hat) and wireless network connectivity. User can connect to either according to preference. It also consists of a micro USB port to which the storage device will be connected ("Buy a Raspberry Pi Zero W – Raspberry Pi," n.d.).

Threading is used such that the user will be able to download multiple files simultaneously. Raspberry Pi module is coded using the python language and Python-Firebase library is used access Firebase from raspberry pi. Python function will be called when the user enters a new URL is added to the mobile application. After the device obtains the URL link from Firebase, it will start downloading the requested file using HTTP, HTTPS and FTP (File Transfer Protocol) protocols

Firebase can be considered as mobile and web development platform that comprises with tools and mechanisms to analyse, authorize, file storage, push message, etc. data ("What is Firebase?" n.d.). The role of Firebase in the system is it acts as the central database between the Raspberry Pi module and the mobile application. Firebase will be responsible for passing the URL links entered

through the mobile application to the Raspberry Pi module. It is also responsible for updating the mobile application, providing real-time download status of the file.

The user is required to enter the URL information of the file that is to be downloaded to the Android mobile application. This URL will be forwarded to the device via a Firebase platform. Once the necessary information is received by the device, it will begin downloading the requested file stored in the URL link from the network it is connected to and store the downloaded file to the storage device connected to the system.

The mobile application used in this system is build using Android Studio. The android application was chosen for this set-up because of the platform's flexibility, fast and feature-rich emulator and compatibility with the set-up. Also, a mobile application can be considered portable and can be operated popularly used smartphones. Functions such as entering URL link into the system, pausing, resuming, stopping, restarting, deleting or scheduling the download can be accomplished through this. Real-time updates of the download will be displayed on the mobile application.

A storage device used for the proposed system set-up is a portable Hard disk (storage device can depend according to user preference). However, this storage device can be chosen according to user preference. After the files are downloaded and saved in the storage device, the user can eject the storage device and access the stored files through a computer.

## **Result & Discussion**

The user uses the mobile application to provide a URL link to the system. The downloading device that is at a remote location will begin downloading the file stored in the specific URL location that was



provided into the mobile application. The downloading device will use the network it is connected to in the remote location to download the specific file and store in the storage device (External Hard Disk – 500GB). Hence the user will have the ability to download files from a separate network at a remote location.

To understand user reaction to the proposed system, it was presented to the same few testers were selected randomly to survey existing download mechanisms and applications. Also, a questionnaire was presented to them to acquire feedback about the functionality of the proposed system. The testers were first briefed about the functionality of the system and given to testing the system. Many testers considered the system a useful approach to download files, without using in-use devices' resources and storage. Hence, majority of the users agreed that the system is useful and was successfully implemented.

Testers also agreed that the system preserve resources of the device that is being used to control the downloading device. Although, mobile application consuming mobile phone resources was considered an issue.

Hence, it was evident that the functionality of the system fulfils the set-out objectives.

### Conclusion and Further Works

eRemote file downloading device is a remote file downloading device that uses Raspberry Pi module as the main downloading device, Android mobile application as the controlling device and Firebase as the database connector between the device and the mobile application. This system allows the user to download files from a separate network by connecting the device through Ethernet or Wi-Fi to that specific network. The mobile application is used to enter URL links of the downloads and further, manage the download (resume, pause, stop, restart and delete).

Further, this system can be improved by developing the same set-up using Microcontroller ESP8266 instead of Raspberry Pi module. ESP866 microcontroller has TCP/IP stack as well as supports Wi-Fi and wired networking, which are all the acquired requirements of the downloading component. Since this microcontroller is less costly, the cost of implementing this set-up will drastically. Hence, due to affordability, it will ensure the availability of the system.

### References

- 10+ Ways to Get the Best From Internet Download Manager: Super Tips, 2015. Deal. Blog. URL <https://www.dealicious.com/blog/idm-unknown-features/> (accessed 7.19.20).
- AnyDesk | Your Remote Desktop Application for Windows 10 [WWW Document], n.d. AnyDesk. URL <https://anydesk.com/en/downloads/windows> (accessed 7.18.20).
- As social engineering activities increase buyer beware of tech support scams | Verizon Insights Lab [WWW Document], n.d. URL <https://web.archive.org/web/20171201013334/http://www.verizonenterprise.com/verizon-insights-lab/VES/as-social-engineering-activities-increase-buyer-beware-of-tech-support-scams> (accessed 7.18.20).
- Buy a Raspberry Pi Zero W – Raspberry Pi [WWW Document], n.d. URL <https://www.raspberrypi.org/products/raspberry-pi-zero-w/> (accessed 7.18.20).
- February 5, A.B., Reply, 2018, 2016. Torrents Explained - Benefits, Disadvantages, Alternatives [WWW Document]. VPN Guru. URL <https://thevpn.guru/torrents-explained-benefits-disadvantages-privacy-vpn-proxy-anonymous-usenet-alternative/> (accessed 7.17.20).
- Han, J., Chung, T., Kim, S., Kim, H., Kwon, T., Choi, Y., 2010. An Empirical Study on Content Bundling in BitTorrent Swarming System.
- How Does BitTorrent Work? [WWW Document], n.d. URL <https://www.howtogeek.com/141257/htg->

explains-how-does-bittorrent-work/ (accessed 7.17.20).

How Internet Download Manager (IDM) works? Interesting facts you may not know about best download manager - Cyber Programmers - Learn Programming [WWW Document], n.d. URL <https://www.cyberprogrammers.net/2018/08/how-internet-download-manageridm-works.html> (accessed 7.19.20).

How to Remove the IDMan.exe Virus? | IDMan.exe Malware [WWW Document], n.d. URL <https://file-intelligence.comodo.com/windows-process-virus-malware/exe/IDMan> (accessed 7.19.20).

How to Use TeamViewer: All You Need to Know [WWW Document], n.d. TeamViewer. URL <https://www.teamviewer.com/en/documents/> (accessed 7.18.20).

Internet Download Manager Features: reliability, high speed, and 24h support [WWW Document], n.d. URL <http://www.internetdownloadmanager.com/features2.html> (accessed 7.19.20).

Legitimate Application AnyDesk Bundled with New Ransomware Variant - TrendLabs Security Intelligence Blog [WWW Document], n.d. URL <https://blog.trendmicro.com/trendlabs-security-intelligence/legitimate-application-anydesk-bundled-with-new-ransomware-variant/> (accessed 7.18.20).

Mushroor, S., Haque, S., Amir, R.A., 2019. The impact of smart phones and mobile devices on human health and life. *Int. J. Community Med. Public Health* 7, 9. <https://doi.org/10.18203/2394-6040.ijcmph20195825>

RBI AnyDesk Warning: Fraudsters can use this app to steal money from your bank account, stay safe | Zee Business [WWW Document], n.d. URL <https://www.zeebiz.com/india/news-rbi-anydesk-app-warning-against-fraud-upi->

payments-do-this-to-save-money-86274 (accessed 7.18.20).

Soffar, H., 2016a. Internet Download Manager (IDM) features, advantages and disadvantages. *Sci. Online*. URL <https://www.online-sciences.com/computer/internet-download-manager-idm-features-advantages-and-disadvantages/> (accessed 7.19.20).

Soffar, H., 2016b. TeamViewer uses, advantages and disadvantages. *Sci. Online*. URL <https://www.online-sciences.com/computer/teamviewer-uses-advantages-and-disadvantages/> (accessed 7.18.20).

TeamViewer – The Remote Connectivity Software [WWW Document], n.d. TeamViewer. URL <https://www.teamviewer.com/en/> (accessed 7.18.20).

TeamViewer V4 desktop collaboration app now Mac-compatible | Macworld [WWW Document], n.d. URL <https://www.macworld.com/article/1138757/teamviewer.html> (accessed 7.18.20).

Torrent: Disadvantages and Controversies - DotNet Guide [WWW Document], n.d. URL <https://dotnet.guide/internet/torrent-disadvantages-and-controversies.html> (accessed 7.17.20).

What is Firebase? [WWW Document], n.d. Educ. Interact. Courses Softw. Dev. URL <https://www.educative.io/edpresso/what-is-firebase> (accessed 7.17.20).

Will Internet Download Manager Work For You? My Complete Review., 2016.. *Genuine Softw. Rev. Site*. URL <https://www.dvd2dvd.org/idm-internet-download-manager-review/> (accessed 7.19.20).

## The Internet of Things for Health Care: A Comprehensive Survey for State-of-the-art Architecture

APL Madushanka#, U Dissanayake, KPMI Ramanayake, SMK Hemali and RPS  
Kathriarachchi

*Faculty of Computing, General Sir John Kotelawala Defence University*

# manoshiramanayake@gmail.com

**Abstract:** the internet of things (IoT), a massive area that makes smart gadgets and captures the development of smart cyberphysical networks. Healthcare is the most important factor which directly connected with the community and development of any country. Latest example is Covid-19 virus and it has directly affected the economy and the day-to-day life of most of the countries. This survey advances IoT based innovative solutions and technologies in healthcare and analyses applications, platforms, and network architectures (state-of-art), new industry trends in IoT based healthcare, and data security and privacy. As per now ambient intelligence, big data, wearable devices, and augmented reality are the new innovative things in the field. The survey is based on a literature review and with the information that the literature reviewer collected representing the data. In this survey, the authors will be reviewed the IoT based healthcare technologies, solutions, applications, issues, challenges in state-ofthe-art architecture and how IOT will affect sustainable development in the economy and society.

**Keywords:** Internet of things, health care services and applications, architectures, platforms, IoT security, industrial trends, challenges

### Introduction

IoT or Internet of things is the internet connected billions of physical devices around the world and these devices collect and share data. The arrival of super-cheap computer chips and ubiquitous wireless networks

make everything do possible today. By connecting different projects and using sensors to these will add a higher level of digital intelligence these projects and it will be helpful to communicate with real-time data without involvement of a human being. IoT will merge digital universe with physical universe and also it will fabric the world smarter and responsive. Benefits of using IoT includes improvement in safety and security, increase in productivity, enhancing asset utilization, efficiency in processes and cost saving.(Islam et al., 2015) Another benefit of IoT includes advanced connectivity of systems, projects, devices and systems. And also, IoT provides solutions for the problems related with applications such as Security, industrial control, health, road traffics control, logistics, waste management, retailing process, and smart city. Out of the above-mentioned applications, health care takes a major role as well as ad attractive interesting application which uses IoT these days. IoT has risen some medical applications like remote patient monitoring, wearable like fitness bands, fitness programs, elderly use, for chronic diseases and infectious diseases or a kind of epidemic situations in the world.[2] The latest example is the rise up of Covi-19 virus, many people including students, doctors and new inventers moved to prepare new gadgets using IoT and robotics. Within last few weeks a lot of IoT based applications came up to this world to find solution for giving treatments to Covid-19 patients without going to them. This will help to reduce the spreading of the virus to people who work in medical field.

Then the doctors can check and assign medicine and also nurses and attendants can provide all the necessary stuffs including food, medicine and others using these gadgets to the patients. This recent incident has tended Sri Lankan inventors to think innovatively and they have risen up with new brilliant innovations to this world. Smart devices such as diagnostic devices, imaging devices, medical devices and sensors are the core part of IoT. Main expectations of IoT based health care services are increasing the quality of life of patients, enhance or enrich the user's experience and reducing the cost. (Amendola et al., 2014) The contribution of this study is to give a review on IoT based applications and services and health care sector, architectures and networks used in IoT, Security and privacy related with IoT based healthcare and new trends and challenges in healthcare applications related to IoT.

### Research Methodology

The Internet of things (IoT) is a massive area that consider the global technology in the world. Our workload is to determine the IoT technology used in healthcare. For these aspect research must focus to evaluate the technologies that are used past and current situations through the research materials which are published in the internet. And work projects did the participant observations for the government hospitals and private hospitals in different time periods. In that there are senior management and lower management. For these aspects overall use of technology high percent in the senior management staff. They are working with the technological machines with related to IoT. As the viewpoint there are various of technologies used with the IoT in Healthcare. Commonly, according to the research papers in past era they had been used manual use of testing in healthcare with different technologies and currently it can be vastly developed to the automate system using int

the IoT based technologies. There are different kind of IoT architectures and platforms that are used in past era and presently. Development of architectures there can be security threat in the present situations. So, security aspects there can be security patches using any of these technologies with the IoT in healthcare. According to research analysis physical security is needed of any technology that we used in IoT Healthcare.

### Healthcare Services and Applications

IoT based health care applications are most probably interact with IoT based healthcare services. These Applications are developed using these services. Here application is user-centric, and service is developer-centric. Proactive systems are converted to reactive systems using IoT applications. IoT will improve power, availability and accuracy of existing devices. Through this section health care devices, wearable and other gadgets available in the market of health care sector is revealed. Figure 1 (Islam and Korea, 2018) will show the services and applications in IoT healthcare.

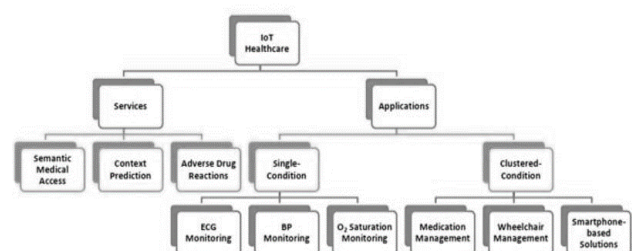

Figure1- Services and Applications in IoT [3] Healthcare

Figure1- Services and Applications in IoT [3]

These gadgets, products, applications and systems can be defined as innovative health care solutions. These IoT based systems consist of diverse fields such as single solutions, clustered-condition solutions, to care elderly patients and to care pediatrics. Some IoT based applications are reviewed here.

- Glucose level sensing an application used by diabetic patients. It will records blood

glucose level over a protracted period. Blood glucose level of an individual is recorded, and this will help to manage the meals, and treatments. [1]

- Blood pressure monitoring is an integrated KIT of blood pressure (BP) and Near Field Communication (NFC) enabled mobile phone. From this application BP can be controlled remotely through communication structure between the patient and the hospital.

- Through Oxygen Saturation Monitoring, Heartbeat oximetry is required check blood oxygen immersion noninvasively. In this application it has combined IoT with Heartbeat Oximetry. This is a very useful IoT based health care application. The function of the wearable is to indicate oxygen level. This device is connected with a Bluetooth health device profile. Here the sensor is directly connected with the Monere platform.

- ECG Monitoring or Electrocardiogram monitoring is an electrical activity of the heart recorded by electrocardiography. Heart rate measurement is included in this and even a simple heart rate change or rhythm can be able to capture. This will be helpful to diagnose of multifaceted arrhythmias, myocardial ischemia, and protracted QT intervals.(Islam et al., 2015) With the rise of a smart phone-controlled sensor, smart phone can be identified as the driver for IoT. Most of the IoT based healthcare devices and applications are designed to use on smart phones. These include resource sharing services, cross-connectivity protocols for heterogeneous devices, notification services, internet services, and link protocols for major connectivity. Lowpower discovery of devices and services can be added to this service list with efficiency and security.

- Ambient Assisted living (AAL) is an IoT based platform combined or powered by Artificial Intelligence (AI) to address elderly

incapacitated individuals. This will be more effective to solve problems associated with health care of aging and incapacitated individuals. This will help them to have their living in a convenient and safe manner. This may help to improve individuals confidence by ensuring autonomy and giving them assistance similar to human servant in any situation.

- The Internet of m-Health things (m-IoT) is not anything else it is mobile computing, medical sensors and communication technologies for health care services. This model connects with 6LoWPAN with 4G networks. Conceptualization of m-IoT services leads for this.

- Adverse drug reaction or (ADR) is the injury of taking medicine. This will happen after a single dose of a drug or its prolonged administration or as a consequence of a combination of two or more drugs. Here the patient's terminal identified by using barcode and NFC enabled devices. Pharmaceutical information system is used to check whether the drug is compatible with electronic health record and allergy profile.(Sethi and Sarangi, 2017)

- The concept of establishing a network covering of an area is monitored under Community healthcare. This will be an IoT based network of a residential area, municipal hospital or a rural community. To materialize Community Health (CH), this network is integrated with Wireless Body Area Networks (WBAN). Sometimes CH can be called as a virtual hospital.

- Children Health Information is raising awareness about children's health and provide needs of children with mental problems as well as physical, behavioral and emotional problems. This situation has motivated researchers to do develop IoT based Children Health Information to address these needs in an effective way. Through this system it will be helpful to

encourage children to have nutritious food with nutritional habits.

- Embedded Context Prediction or ECP is used to build context-aware healthcare applications through IoT based networks. Some generic frameworks with some helpful mechanisms are required by the third-party developers is called ECP. Still there are some uncovered and unsolved research problems and challenges in context-aware ubiquitous healthcare systems.

### **Key Technologies of Iot Used In Healthcare**

Healthcare is a key sector where today IoT is rapidly adopted to IoT solutions by creating IoT medical things. There are some supportive technologies which are helpful to IoT in developing these smart gadgets. Figure1- Services and Applications in IoT [3] Healthcare

#### **A. Internet technology**

Internet technology means the software, hardware, devices and transmission protocols used to connect to a network and send or receive data. To communicate any person with and object at any time at any place, the precondition required is Internet

#### **B. Sensor Network Technology**

This is considered as the core of the IoT and it can be operated with RFID systems to track status better. Sensor networks has a certain number to communicate in a wireless fashion. Continuous development of Science and technology and traditional sensors the procedure of microminiaturization, intellectualization, informationization and networked. Environmental monitoring, e-health, intelligent transportation systems, military, and industrial plant monitoring are the application scenarios where use sensor networks.(Yu, Lu and Zhu, 2012) The sensor network connects to the Internet, an enterprise WAN or LAN, or a specialized industrial network so that collected data can

be transmitted to back-end systems for analysis and used in applications.

#### **C. Wireless Communication Technology**

Through Wireless communication technology it transmits information stored in RFID tag automatically to central information system. Therefore, this can be considered as core technology in IoT. Wireless communication technology includes Bluetooth, WIFI, UWB (Ultra wide band), Zigbee, IrDA (Infrared Data Association) and more. (Nazir, Ali and Ullah, 2019)

#### **D. Embedded Technology**

Based on internet, IoT is considered as an embedded system. Here more intellectual terminal products have requirements to network. Here it uses IoT concept for production. Output of the embedded technology development and it cannot do extensive use without embedded technology supporting is IoT. [5]

#### **E. Cloud Computing**

The integration of cloud computing with IoT will provide ubiquitous access to shared resources, and it will offer services or requests to the network. and also it will help to execute operations to meet certain needs.

#### **F. Grid Computing**

By introducing grid computing to the ubiquitous healthcare network, the problems related to insufficient computational capability of medical sensor nodes can be solved. When Grid computing is more accurate in cluster computing and it is viewed as backbone of cloud computing. (Islam et al., 2015)

#### **G. Big Data**

This includes large amount of essential data generated from sensors and other tools. This will increase efficiency in health diagnosis and monitoring. (Nazir, Ali and Ullah, 2019)

### H. Ambient Intelligence

For the continuous learning of human behavior and to trigger a recognized event, ambient intelligence is used. The capability of IoT-aided healthcare services are enhanced by the integration of autonomous control and Human computer interaction (HCI) technologies into ambient intelligence.

### I. Augmented Reality

It is a part of IoT. It plays major role in healthcare engineering. It is used for surgery and remote monitoring, among others.

### J. Wearable

By embracing wearable medical devices can improve patient engagement and population health improvement. Benefits of wearable includes connected information and target-oriented healthcare communities. (Internet of Things and Advanced Application in Healthcare - Google Books, no date)

### IoT Architecture and Platform Used In Healthcare Industry

The IoT architecture prefers the outline analysis of the organizational functions and working principles of their techniques. Architecture vary from organization to organization and they have built the system according to the situation of their concern factor. All the new technology we can process to the convert to architecture, but we have to concern the what the purpose we are using and what the benefit of this devices and get the maximum output of the IoT devices for the benefit of the organizations as show in Figure 1.

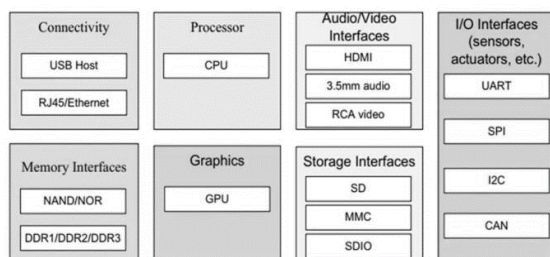

Figure2- IoT devices [8]

Figure 2: IoT devices

IoT platform refers to both the network platform model and computing platforms. Internet of Things (IoT) refers to the stringent connectedness between digital and physical world. Various researches have analysis IoT in different ways. The IoT architecture can be a system that can be physical, virtual or a mixture of two, consisting of a collection of several active physical things, networks, devices, actuators, cloud servers and specific protocols of IoT, developers, companies and customers. Using these devices, such as Figure. 2 Figure2- IoT devices (Ray, 2018) connects the base of the system and provides actuation, control and monitoring activities, and also the devices can exchange data between servers to obtain responses and deliver the responses to the relevant receivers. IoT devices have many interfaces to communicate between centralized servers, such as various types of portable sensors, smart watches, LED lights, cars, and industrial machines. (Ray, 2018)

Things, their interconnection to the Internet, by directly or through local area networks, and how they communicate with each other, with the cloud and with mobile device applications. This includes device identification and addressing as well as typical communication protocols to be come upon. The hardware architecture and implementation of a thing will be defined, including its sensors, actuators, intelligence, identification, communications, power, and hosting. Thing's firmware architecture and firmware implementation will be explored in a similar way, considering its operating system, sensor and actuator interface, communications protocol stack, configuration, and status monitoring. The architecture of the cloud system will be discovered, with virtual cloud servers, data warehousing, and services offered by providers such as Amazon Web Services and Microsoft Azure. This will contain the

procedure to establish a cloud-based server system.

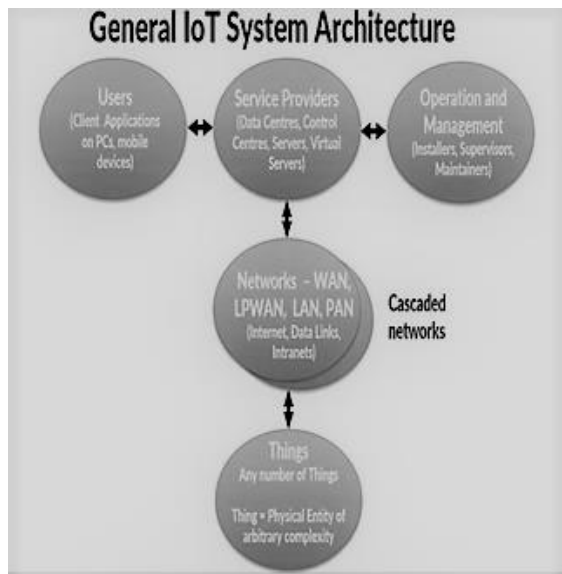

Figure 3- IoT System Architecture

As per author illustrated from figure. 3, general IoT system architecture, user access via the mobile applications, PCs, any devices to the relevant destination but there is route to process to cover. User can reach to the physical entity through the service providers controls. It will be enabling by the operation and management then it passed through the networks. Then user can reach to the physical entity without interference. The IoT is a global network that link with different types of objects anytime, anywhere and anyplace through current internet protocol called Internet Protocol (IP).

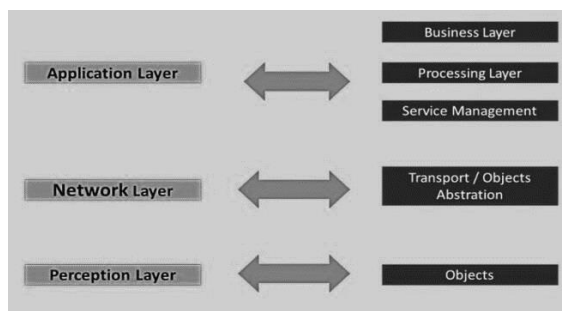

Figure4- Layers of IoT architecture

According to most researchers' views on conventional IoT architecture, it is measured as three layers: (Perception Layer, Network

Layer, and Application Layer) and it is illustrated by the author from Figure 4.

The perception layer (recognition layer) is the deepest layer of conservative IoT architecture. The main accountability of this layer is to collect useful information / data about things or the situation and transform them in a digital setup. The main determination of the objects is the unique address identification and communication between short-range technologies like RFID, Bluetooth, Near-Field Communication (NFC), 6LoWPAN (Low Power Personal Area Network). (Sethi and Sarangi, 2017) The lower layer of the IoT architecture perception layer represents an object layer. The main responsibility of the object layer is to gather data from different devices of varied category and then procedure and digitize the data. It also transmissions the managed data to the upper layers of the IoT architecture.

Network layer is the intelligence of conventional IoT architecture. The main concern of network layer is to assistance and guarantee the transmission of data between the application and the IoT perception layer architecture. Network layer mainly gathers information and delivers it to the perception layer to various applications and servers. Basically, network layer is a junction of internet and communication-based networks. According to a existing study carried out in several based-on communication-based technologies, the researchers determined that the network layer is the most industrialized layer of conventional IoT architecture. It is the central layer (network layer) of IoT6 that is capable of proceeding information for relevant procedures and applicable for data processing tasks handled IoT management. (Iablonskaia, 1970) This layer also confirms unique routing and routing abilities for the unified addition of countless devices into a single cooperative network. Several types of



technologies are providing for this such as wired, wireless and satellite. The innovation of the 6LoWPAN protocol towards IPV6 for the unique addressing of IETF devices demonstrates a high degree of effort involved. The central layer of the conventional IoT architecture network layer represents an object abstraction layer. The object abstraction layer performances as a Figure3- IoT System Architecture (IoT System and Device Architecture and Implementation - Webinar - EA Books, no date) Figure4- Layers of IoT architecture intermediary layer between service management and the object layer. In the concept of objects, RFID, WIFI and Third Generation (3G) communication technologies are used. The transport layer transmits the device data from the perception layer to the processing layer and across networks.

The application layer is measured a top layer of the conventional IoT architecture. This layer provides personalized / customized services based on the relevant requirements of the user. This layer main responsibility is to connection the main gap between users and applications. This IoT layer trusts the industry to achieve high-level smart application type solutions such as disaster monitoring, health monitoring, transposition, wealth, medical and ecological environment, and managed relevant global management for all type smart applications. (Banu, 2018) The application layer is divided into sub three categories for their basic functionalities. The primary tasks of the service management layer are to enable information processing, decision making, and controller of union requestor information processing for relevant tasks. The application layer delivers customers with high-quality smart services according to customers' request. The business layer concern about the business model and the data that has been established from the

application layer. The processing layer performs as a store, analyzes, and processes huge quantities of data that delivered from the transport layer. It can provide services to the lower layers. It services many technologies such as databases, cloud computing, and big data processing modules. The business layer achieves the entire IoT system, including applications, business and income models, and user's privacy.

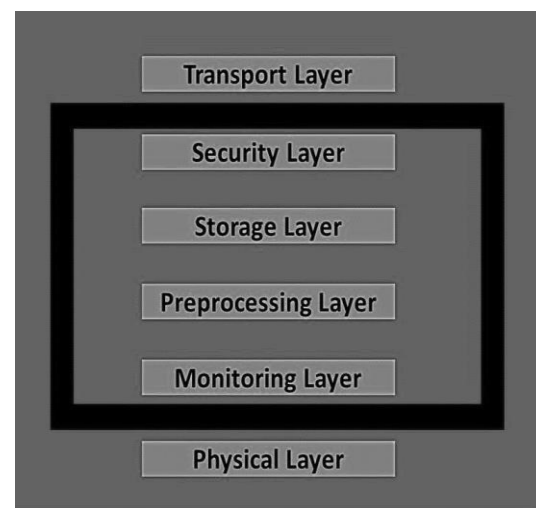

Figure 5- Fog architecture

In fact, some researchers observed at one more layer that is also included in IoT latest architecture which is a support layer between the application layer and the network as shown in Figure. 5. Some of the researcher's experiential of the IoT as consisting of four layers of architecture. The fourth layer is considered a support layer (the technologies used in this new layer are cloud computing, smart computing, fog computing etc.) that invention between perception and the conventional IoT network layer architecture. The support layer contains of fog computation and cloud computation. Cloud computing and fog computing are urban topic nowadays in research view of mostly finalized researchers on IoT architecture. Cloud and fog-based architectures.

Let us now discuss two types of system architectures: cloud computing and fog computing. We have been a bit vague about

the nature of the data generated by IoT devices and the nature of data processing. In some system architectures, data processing is done centrally by cloud computers such as cloud-centric architecture keeps the cloud at the center, applications. Cloud computing takes precedence because it provides great flexibility and scalability and provide services such as core infrastructure, platform, software, and storage. Developers can offer their storage tools, software tools, data mining and machine learning tools, and visualization tools concluded the cloud. Lately, there is a move towards another system architecture, namely fog computing where sensors and network gateways are a part of data processing and analysis. A fog architecture structures as a layered approach and it provide the monitoring, preprocessing, storage, and security layers between the physical and transport layers. The monitoring layer controls power, resources, responses, and services. The preprocessing layer makes filtering, processing, and analysis of the sensor data. The temporary storage layer offers storage functionalities such as data replication, distribution, and storage. Finally, the security layer performs encryption / decryption and guarantees the integrity and privacy of the data. Monitoring and preprocessing are done at the edge of the network before sending data to the cloud. (Sethi and Sarangi, 2017)

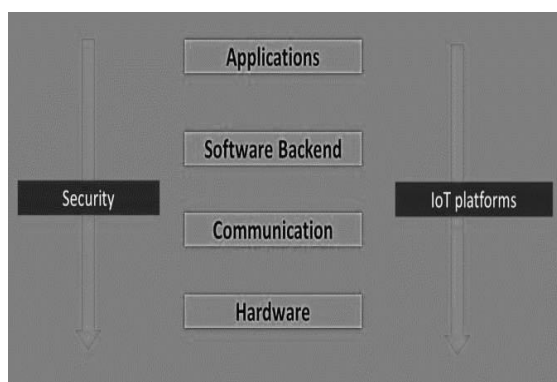

Figure6: IoT platforms

According to the Figure 6. IoT platforms are build up with the IoT architecture requirements. Hardware - The data is

produced, and the hardware layer contains the physical devices with the integrated microprocessors, sensors, actuators, and communication hardware.

Communication: The data is transported, and this part of the technological infrastructure guarantees that the hardware is connected to the network, through patented or open source communication protocols.

Backend Software - The data is managed, and the software backend completes all connected devices and networks and platforms provides the necessary data integration as well as the interface to other systems.

Applications: The data is converted to value in the application layer and IoT use cases are provide to the user. Most applications run on smartphones, tablets, PCs or other devices and with the data. Security is vital element for all these basic components. The IoT infrastructure essential to be comprehensively designed because the threat of attacks is reduced at all levels. This includes protecting and encrypting data and metadata, managing device access, authenticating users. (IoT Analytics, 2015)

### Security in Iot Based Healthcare

Article 12 in universal declaration of human rights, “No one shall be subjected to arbitrary interference with his privacy, family, home or correspondence, nor to attacks upon his honor and reputation. Everyone has the right to the protection of the law against such interference or attacks.”(Assembly et al., 1948)

A major issue in today’s technology driven world can be considered as security and privacy of data and information. Privacy means preventing from anonymous, unauthorized data access or data hiding. There are many data hiding techniques such as Anonymization, Generalization, Perturbation, Role Based Access Control,

Encryption and many more and still developing. Strong privacy techniques are open research problem.(Churi and Pawar, 2019) Data have many different phases in their life cycle. storage of data, transition of data, transfer of data and processing of data are the stages or the phases in life cycle of data.(CAJIGAL, 2008)

According to(Krishna, Gurumoorthy and Obaidat, 2019) health care industry is a most rapidly developing industry. There were huge changes last few decades in integrating Information communication technology. Latest technology of health care shifted from disease centered to patient centered. Where patient can choose. It generates huge amount of data on patient. To get effective results, industry needs to increase data utility. This means it transmit huge amount of sensitive data. So now you can understand how crucial data security and privacy important. Health care industry must manage and safeguard personal information to address those privacy issues to process and analyze those industries must follow specific rules and regulations. If not, we must develop such kind of rules and regulations or set protocols to follow. there are some rules carried different countries. (Abouelmehdi et al., 2017)

According to (Krishna, Gurumoorthy and Obaidat, 2019) Data encryption is a data protection method which avoiding any unauthorized user access. For that we can use encryption algorithms such as RSA, DES, RC4, AES. Authentication prevent unauthorized accessing of e-health records. secure socket layer (SSL) and transport layer protocol (TLP) are cryptographic protocols by applying these protocols we can strengthen security. Access control granted separate privilege to each user. These roles have different capabilities. Sequence access control (SAC) is another technique. These are initiated after authorized user access the system. Masking is hiding sensitive data

values or convert into unidentifiable string. Which is not like in encryption. But it uses a unique decrypt method. Those are basic methods.

To provide best solution to health care industry smart systems are employed. To effective communication between machine to machine provided through cyber-physical system (CPS). It is a framework described in(Krishna, Gurumoorthy and Obaidat, 2019)

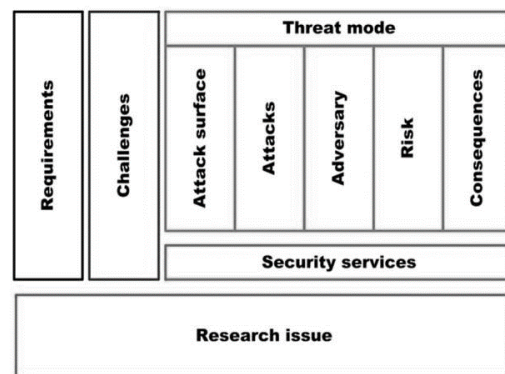

Figure 7: Security issues in IoT-based health care(Islam et al., 2015)

Figure 7 shows Security issues in IoT health care industry. Security requirements of standard communication scenariosand IoT based health care solutions are most similar. To achieve secure service these devices, need to apply security requirements like confidentiality, integrity, authentication, availability, data freshness, non-repudiation, authorization, resiliency, fault tolerance, self-healing.(Islam et al., 2015)

Traditional techniques won't work anymore with security of IoT. New countermeasures wanted to be introduced whenconsidering health care challenges there is some points thatwe should consider.

- IoT has less powerful CPUs which only uses for actuator or sensor. These devices are not designed for heavy computational operations. Find a security solution forlimited resources that lightweight solution is a big challenge.

- IoT has low memory it is not enough to run complicated security protocols.
- BP sensors and body temperature sensors those consumes huge amount of power. Even though when no need to report any sensor readings, device conserve in power saving mode. This is also a challenging property.
- IoTs are mobile and wearable. So that person who owned the device travel here and there. Home, office, market. So, device will connect internet with different networks which has different security configurations. So, designing a security solution such a device is more challenge.
- By now there is so many IoT devices connect with the internet. Designing a highly scalable security solution is a challenge.
- Normally IoTs are connected using Bluetooth, Zigbee, Z-Wave, WiFi, GSM, WiMax, and 3G/4G to the network. Traditional security protocols for wired media will not helpful for these devices. These protocols need to develop for catering both wired and wireless devices equally.
- IoT devices have variety of diversity from PCs to RFIDs in healthcare industry. Multiplicity of these devices are huge challenge in designing in security solution for compatible with all the devices.
- In IoT health care devices can connect with the network anytime and anywhere. It may leave the network in same way. This reason make network dynamically. So, security should be providing into that also which is a challenge.
- IoT devices may communicate with other devices in the LAN same time it may communicate with IoT service provider over the IP network. It's difficult to develop a security solution for multi-protocol communication.
- IoT devices may have to update to date. To mitigate vulnerabilities. Designing a

update mechanism with security patches with dynamic installation is a challenge.

- Tamper resistant package will enable physical security of IoT devices. Intruder may tamper the device and extract cryptographic algorithms or replace malicious software with in it. So this package will resist such attacks and these kind of packages difficult to implement. (Islam et al., 2015)

### **Healthcare Industry and Status**

IoT in health care field has experienced as well as comprehensive activity and creativity, researchers wish future market are willing to be part of these enabling products and technologies. Sensing interoperability, lifelogging mode and uncontrolled environment are the future research trends. Interoperability especially distributed in network layer and processing layer. Current days many approaches and bio medical platforms have been proposed for sensing interoperability. However, in this section mention an extensive list of IOT in health care product and technologies. The latest technology of real time tracking has many features such as GPS tracking, got updated alerts, mobile data and short messaging services. Using those technology developed number of healthcare devices. BP machine and app is one of the example, had develop baby monitor.

In recent years Chinese firm has developed MI platform and integrated telemedicine competence. They developed the platform supporting cloud-based image storage, 3D image post-processing and visualization. The main firm of Neusoft has focused on IOT based healthcare services. And they provide their services for hospitals and public health facilities and health management. (Islam et al., 2015) a recent time period society oriented by U-healthcare (Ubiquitous) which monitors man's health condition and provide health care services wherever it is needed. Ubiquitous health care that provide

healthcare services using remote medical technologies without any limitation in time and space. This system can monitor bio-information in real time using certain devices and mobile equipment in a home network. U-healthcare system can be classified as sensing, monitoring analyzing and alter according to the role in a system (Lee, 2016)

Ranging from pilot project to effective implementation of eHealth and IOHT (Internet of healthcare things) based health services and policies have been adopted successfully in many countries worldwide. In future countries will making new policies and shifting towards eHealth and IOHT enabled network. The newly concept in healthcare industry call High volume of data. It has contained the lifelogging collection of physical activity data of personal health information. These data collect by using heterogeneous devices connected in IOT environment (Albeshir, 2019)

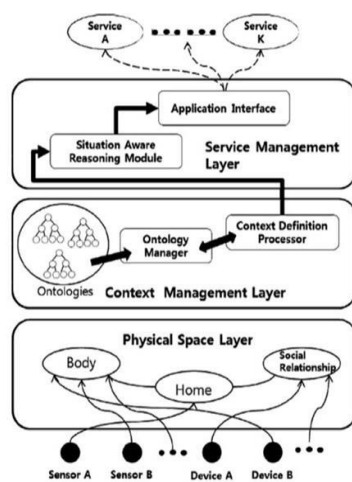

Figure8 - Platform of smart home-based healthcare system (Internet of Things and

Effectively and efficiently improving validity of these complex health related data and exploring is difficulty task. Researchers was experiment how to explore these healthrelated big data deal with IOT environment. Lee & Kwon, 2013 was proposed a platform for the smart home healthcare system as shown in Figure 8. It

handles wide range of context generally occur in the house. After collecting various types of sensor data and define what situation currently happen at home space. The architecture of the proposed platform has main three layers: physical space layer, context management layer, and service management layer. (Internet of Things and Advanced Application in Healthcare - Google Books, no date)

Garmin's vivo smart is a fitness checking band or smart watch that can consider the user active way. Jawbone's UP3 is the same device of vivo smart band but UP3 is many state-of-the-art sensors and it can capture the full picture of Figure8 - Platform of smart home-based healthcare system (Internet of Things and Advanced Application in Healthcare - Google Books, no date) patient's health status. An iHealth lab team was found a set of extensive products such as wireless BP wrist monitor, BP dock, wireless body analysis scale iHealth lite, iHealth Edge, iHealth Align and wireless smart glucose-monitoring system. They basically developed a health tracker that can help tracking user's daily activities. (Islam et al., 2015)

Phyode's has introduced a smart health wrist band that can monitor the patient heart rate variability. Rejuwan's introduce by total health measuring ECG machine and also monitor heart rate variability, respiratory rate, sleep position, restfulness, breathing index and energy level. Those devices can investigate the state of the autonomic nervous system. Considering with globalization many countries are facing challengers of elder care, wearable sensors more related to consider elders heath measures meantime chronic diseases are becoming the major cause of death. Who felt chronic diseases most probably they want do surgeries then after the surgery they want proper monitoring system to measure their health condition? As a result measurement of vital signs and corresponding diagnosis are

carried out in controlled environment. However, wearable medical or healthcare devices are the key element that will catalyze the process. Wearable sensor devices can be connected directly to internet through an access point, or it may connect to an internet enable device through Bluetooth. Wearable sensor devices measure the health factors and it connected to internet or user's smartphone or tablets. Those are the IOT based devices. Wearable body area network are crucial component of the medical IOT. The term of (IOT) namely the concept of interconnecting physical object to each other or the internet to create domain-specific intelligence through seamless pervasive sensing, data analysis and information visualization (Qi et al., 2017)

With an increase in disease, medical support is also growing in today's social world. As a result, doctors' patients frequently increase. Most Asian countries and third generation countries can involve the public health sector and the lack of technological support in which health services are provided to patients. Smart home concept that integrates health function and environmental assisted living technologies In fact, providing healthcare facilities is one of the main functionalities that smart homes offer. This concept of sensors and actuators together with the backbone of communication from the central part. To capitalize on the versatility of wireless medical sensors, there are a growing number of studies looking to create application networks for a wider variety of conditions. These studies use sensors on a wireless body area network (WBAN) to monitor the patient's health. In some cases where devices can communicate via Bluetooth, the data is sent to a user's smartphone for processing and storage.(Pal et al., 2018)

The Medical Internet of Things can consist of many devices and is personalized according to the needs of the user. Common portable

sensors measure heart rate, blood oxygen, blood glucose, body temperature, and gait. These devices can be connected directly to the Internet or to an Internet-enabled device, such as a smartphone, laptop, or tablet. Wearable Body Area Networks (WBANs) are a crucial component of medical IoT. WBANs can be single-purpose sensors, such as pulse oximetry sensors that measure the oxygen level in a user's blood, or more complex devices comparable to Fitbits, which can track location, recording activity, and measuring heart rate. For patients in stable, noncritical conditions, WBAN monitoring enables recovery at home or in a caregiver's home rather than remaining in the hospital under observation after completing primary treatment.

The use of IOT allows multimedia to implement deep and rich communication and interaction between patients and specialists remotely and provides great developments for the industry. Users obtain vital signs with the use of small smart wireless sensors that are used as personal gateway (e.g. smartphones) based on different operating systems (e.g. Android) in small area networks with different protocols, like Bluetooth, ZigBee and WBAN.

### **Challenges**

It is really a nice idea to use IoT in a fast developing and a highly required sector called health care. IoT based devices or IoT based smart gadgets can come up with a little processing speed and some functionalities are limited. In healthcare sector it is a place which deals with real time data transmission. (Nazir, Ali and Ullah, 2019) And there may be a slight delay when leading to a fatal situation. IoT devices can store a less amount of memory and it is a challenge to implement security protocols in these applications with the base of IoT. These IoT devices have the feature called mobility and they are connected with wireless technology and internet. Change in operating system in

mobile phones or changing platform and environments will create security compatibility issues. A global trend has attracted a great deal of attention in terms of integrating smart home technology for the purpose of aiding health monitoring in addition to real-time care in telemedicine. Patient psychological information should be collected in a timely manner and automatically transferred to remote specialists through the network to support and assist patients with the use of smart home technologies for a decent home life in real time. This information is extremely sensitive and private; Thus, most government authorities impose strict policies. (Linkous, Zohrabi and Abdelwahed, 2019)

### Conclusion

Today researchers have moved to do more researches to enhance and improve the health sector by finding new innovative technological solutions with the advance use of IoT. This paper reviews how IoT deals in healthcare sector, technologies used in IoT based healthcare, network architecture and platforms used in IoT, applications and services in IoT based healthcare sector, Security issues, security requirements and security challenges connected with IoT based healthcare, healthcare industry, new trends and challenges in IoT based healthcare. This paper provides detailed research description of current IoT based applications and how people use them and the advantages or the key benefits of using IoT in healthcare. This review will show some new paths to researchers and it will help them to motivate them on these paths. The new technologies that can connect with IoT and use in future applications and services in IoT in healthcare is reviewed in a smooth way. IoT based applications will also help to provide smooth continuous service to patients and can help to get maximum use from the limited resources through efficient scheduling. This

will help more patients to get best use from resources. This paper will give a broad view of the architecture and network platform use in IoT based Healthcare. Security is the major problem that should be considered. Security requirements and challenges and how to overcome these challenges are surveyed through this paper. In this survey, the authors will be reviewed the IoT based healthcare technologies, solutions, applications, issues, challenges in state-of-the-art architecture and how IOT will affect sustainable development in the economy and society. Finally, this paper is expected to be useful for researchers, innovators, doctors, students and health professionals.

### Acknowledgment

It is highly required to express our deep and sincere gratitude to our Senior Lecturer, Mr. Pathum Kathriarachchi, Head of Information Technology Department, General Sir John Kotelawala Defense University for giving us the opportunity to make this research and providing invaluable guidance throughout this. His dynamism, vision, sincerity and motivation have deeply inspired us. It was a great privilege and honor to do a research with him under his guidance.

### Author Biographies



KPMI Ramanayake currently a 3rd year student of information Technology department at General Sir John Kotelawala Defence University. She excels in research as well as studies. In this review paper, she services and applications and challenges.



SMKH Hemali currently a 3rd year student of information Technology department at General Sir John Kotelawala Defence University. She excels in research as well as studies. In this review paper, she has covered the areas in healthcare industry and status.



Capt. APL Madushanka currently a 3<sup>rd</sup> year student officer of information Technology department at General Sir John Kotelawala Defence University. His works focused on security in IOT



Capt. U Dissanayake currently a 3<sup>rd</sup> year student officer of information Technology department at General Sir John Kotelawala Defence University. His works focused on architecture and platform used



RPS Kathriarachchi obtained his BSc (Hons) in computer networks from University of Wolverhampton UK and his master's degree in MIT in the same University. He also a CISCO certified network associate and having more than 15 years of IT and IS systems. His current research interests include Internet of things, Machine Learning, SWARM technologies. He has produced over ten peer-reviewed publications under his name.

## References

- Abouelmehdi, K. et al. (2017) 'Big data security and privacy in healthcare: A Review', *Procedia Computer Science*. Elsevier B.V., 113, pp. 73-80. doi: 10.1016/j.procs.2017.08.292.
- Albeshar, A. A. (2019) 'IoT in Health-care: Recent Advances in the Development of Smart Cyber-Physical Ubiquitous Environments', *IJCSNS International Journal of Computer Science and Network Security*, 19(2), pp. 181- 186.
- Amendola, S. et al. (2014) 'RFID technology for IoT-based personal healthcare in smart spaces', *IEEE Internet of Things Journal*, 1(2), pp. 144-152. doi: 10.1109/JIOT.2014.2313981.
- Assembly, G. et al. (1948) 'Universal Declaration of Human Rights', (December).
- Banu, N. M. M. (2018) 'IoT Architecture a Comparative Study IoT Architecture a Comparative Study', 117(March), pp. 45-49. doi: 10.12732/ijpam.v117i8.10.
- CAJIGAL, S. (2008) 'The Patient Revolution', *Neurology Now*, 4(1), pp. 23-26. doi: 10.1097/01.nnn.0000311177.91615.b1.
- Churi, P. P. and Pawar, A. V. (2019) 'A systematic review on privacy preserving data publishing techniques', *Journal of Engineering Science and Technology Review*, 12(6), pp. 17-25. doi: 10.25103/jestr.126.03.
- Iablonskaia, V. A. (1970) 'Immunogenez u svinok pri immunizatsii razlichnogo tipa rikketsioznymi vektsinami.', *Zhurnal Mikrobiologii Epidemiologii i Immunobiologii*, 47(6), pp. 133-134.
- Internet of Things and Advanced Application in Healthcare - Google Books (no date).
- IoT Analytics (2015) 'IoT platforms. The central backbone for the internet of things.', (November), pp. 1-24. *IoT System and Device Architecture and Implementation - Webinar - EA Books* (no date).
- Islam, S. M. R. et al. (2015) 'The internet of things for health care: A comprehensive survey', *IEEE Access*. IEEE, 3, pp. 678-708. doi: 10.1109/ACCESS.2015.2437951.
- Islam, S. M. R. and Korea, S. (2018) 'The Internet of Things for Healthcare and Medicine'.
- Krishna, P. V., Gurumoorthy, S. and Obaidat, M. S. (2019) *Internet of Things and Personalized Healthcare Systems*. doi: 10.1007/978-981-13-0866-6.
- Lee, H. (2016) 'The internet of things and assistive technologies for people with disabilities: Applications, trends, and issues', *Internet of Things and Advanced Application in Healthcare*, pp. 32-65. doi: 10.4018/978-1-5225-1820-4.ch002.
- Linkous, L., Zohrabi, N. and Abdelwahed, S. (2019) 'Health Monitoring in Smart Homes Utilizing Internet of Things', *Proceedings - 4th IEEE/ACM Conference on Connected Health: Applications, Systems and Engineering Technologies, CHASE 2019*, pp. 29-34. doi: 10.1109/CHASE48038.2019.00020.
- Nazir, S., Ali, Y. and Ullah, N. (2019) 'Internet of Things for Healthcare Using Effects of Mobile Computing: A Systematic Literature Review', 2019.
- Pal, D. et al. (2018) 'Internet-of-Things and Smart Homes for Elderly Healthcare: An End User



Perspective', IEEE Access. IEEE, 6, pp. 10483–10496. doi: 10.1109/ACCESS.2018.2808472.

Qi, J. et al. (2017) 'Advanced internet of things for personalised healthcare systems: A survey', Pervasive and Mobile Computing. Elsevier B.V., 41(600929), pp. 132– 149. doi: 10.1016/j.pmcj.2017.06.018.

Ray, P. P. (2018) 'A survey on Internet of Things architectures', Journal of King Saud University - Computer and Information Sciences. King Saud

University, 30(3), pp. 291–319. doi: 10.1016/j.jksuci.2016.10.003.

Sethi, P. and Sarangi, S. R. (2017) 'Internet of Things: Architectures, Protocols, and Applications', Journal of Electrical and Computer Engineering, 2017. doi: 10.1155/2017/9324035.

Yu, L., Lu, Y. and Zhu, X. (2012) 'Smart Hospital based on Internet of Things', 7(10), pp. 1654–1661. doi: 10.4304/jnw.7.10.1654-1661

## Optimum Shirt Design Prediction Tool for Apparel Industry

KPMK Leelarathne# and HRWP Gunathilake

*Faculty of Computing, General Sir John Kotelawala Defence University*

# maheshileelarathne@gmail.com

**Abstract:** The apparel industry is one of the world's major upcoming trends of industrial, economical science. Apparel industry has interconnected design producing and manufacturing issues have become a greater concern. In the domain of apparel product manufacturing and marketing optimization and prediction the design has played a significant part of increasing productivity, overall profit, the consumer demand, and requirements towards the actual factory. Industry has been challenged over and over before adapted by adopting new methods of designing and predict the optimum garment based on the past records and analytical data sets. In my study Time series Analysis and the trained model is used to determine and predict the optimal product under various production constraints. Time Series Analysis is one of the most accurate data analysis and forecasting technique and it is widely used in this research works. There are various kinds of both the traditional statistical methods and the more advanced artificial intelligence (AI) techniques that have been used in various existing systems in relevant to this domain. Both those methods may suffer considerable drawbacks in which the former's performance depend highly on the time series data's features whereas the latter ones are slow. Hence there need to pay attention for development of an intelligent time series forecasting system which is fast, versatile and can achieve a reasonably high accuracy. Anyhow with the development of computer technology, automated apparel management systems and Machine Learning models are latest popular, especially in products classification and prediction. The proposed work provides analytical

inferences from historical data of sales records for apparel industry and modelling them using time series analytics to make effective decisions by predicting and visualizing.

**Keywords:** Machine Learning, Apparel Management, Design Prediction, Optimization, Time Series Analysis, Products classification, Artificial Intelligence (AI)

### Introduction

The apparel industry is the one of important and dominant sector which impacting on an economy of a country, especially, in developing country such as Srilanka. As well as one of the world's major upcoming trend of industrial phase. From increasing performance of textile manufacturing and tighter process quality control, technology has inserted intelligence at every node of textile supply, production chain. When it considers any apparel industry or garment factory, they may use to manufacture large number of design types per a particular time period, but out of all those manufactured design types it may have the demand for only several design types in the sales market. So, then it may occur a wastage in production and it affect to the overall productivity in the factory. Therefore, it is an important to determine the best-selling design types among the consumers and the textile marketplace. By the forecasting and deciding the optimum design type before manufacturing, it will be able to reduce the unnecessary wastage of the cost, time, resources, and labour etc. So, if it will be able to predict the optimum design and then it may be supportive to address the exact target in the consumer market. Therefore, the aim

of customer-centric product development should be to satisfy demands and requirements of the specific target group and to predict design products that attract user attention and evoke positive emotions. Consumer 's need on technological aspect of product designing is becoming a trend in textile product development to determine their success in the apparel market. The aim of this work is to narrow the research gap of failure to identify optimum garment design types among the market demand and develop a prediction system with time series forecasting models which establishes an efficient and optimum design in the production of apparel industry. The specific objectives are to Critically review the issues and challenges are facing the apparel production strategy, Analysis and forecasting the time series data, Design prediction model to predict the optimum design type for the future production, Implement the application model using appropriate technique and create a user friendly service management dashboard for a better visualization and then evaluate the performance using test data and analyze the data and statistics for further works.

### **Literature Review**

Product optimization and planning to design prediction in the industry is one of the popular research problems that have been developing with various conceptual affective engineering methods and Machine Learning and Artificial Intelligence techniques. Even though there are no similar research works that have done in previously, to analysis and predict garment design in particular apparel company, the following studies were conducted on the analysis and studying areas of the different types of apparel production management systems according to various applications and the techniques had used.

S.K.Tyagi and B.K Sharma(Tyagi, International Journal of Computer Applications (0975 - 8887)) presented the

role of quality control and usage of data mining tools and techniques in Textile Industry. They provided the Computerization through Context-Analysis diagram of the quality control Laboratory in Textile Industry. PromodRaichurkar and RamachandranManickam(Raichurkar and Ramachandran, 2015) have done a detailed survey about Problems and challenges for rapid growth, Optical fiber application in textiles, Marketing Initiatives, Scheme for Integrated Textile Parks, Textile Education and Skill Development, and also reflects that wholehearted joint efforts from manufacturers, buyers, suppliers, government, and other stockholders are highly expected to accomplish the development of potential and sustainable textile industries growth in India.

(Moisanen, May,2014) provide an understanding of the key concepts and issues related to demand forecasting in the apparel industry to investigate the interesting concept of demand forecasting in the apparel industry through secondary research and utilize the findings in a real life. This case study utilizes the findings to c and endorse the most valid forecasting measure and methods by combines both quantitative and qualitative methods. SébastienThomassey, Choi, Hui and Yu, 2013) Proposed a review of the different constraints related to sales forecasting in the textile industry to generate a sale forecasting system. The different types of constraints taken to design the forecasting system is Horizon, Life Cycle, Aggregation, Seasonality, Exogenous variables. Avonigharde conducted a study on forecasting of clothing sales using regression and time series model. EngyShafik presented a Time series Forecasting Model for US Winter Season Apparels based on Seasonality, Economic Condition, Fashion Trends and Consumer Behaviour.

A Fuzzy Line-Balancing (FLB) model (Wong, Chan and Ip, 2001) is proposed to handle the

line-balancing problem of fabric spreading and cutting operations of the apparel manufacturing process using genetic algorithm. And the result indicated and was compared with that of FLB model under the dynamic manufacturing environment. (Li Xia Li, Fanxing Kong, 2011) In this paper, GM (1,1) model is applied to predict the apparel export volume, the results show that the prediction accuracy is better, the forecast shows that china's garment exports are still on the momentum of rapid growth. Optimize structure of our textile and garment industry chain to fight for advantageous position in textile and garment industry depends on brand, design, quality. (Chandadevi Giri , Thomassey, Jenny Balkow 2019) This approach to forecast the sales of fashion products based on deep learning and non-linear NN regression is presented in this paper. Results of this study seem promising for forecasting the future sales quantity of the products. This approach could benefit the designer and fashion retailers in order to carefully studying the sales of the current product and extracting the abstract features hidden in the particular product images, fashion designers and retailers can predict the nature and demand of the products in future.

This study on energy assessment from apparel industries: the context of Sri Lanka (Jananthan, Ameer and Shiyamini, 2006) has attempted to make some recommendation for the energy efficiency by doing a cost benefit analysis for the energy efficiency measures. Operating costs can certainly be reduced by performing energy analysis and diagnostics, leading to efficient energy conservation and management policies. (Tien-you, 2010) The integrated system for optimizing the management and control of apparel enterprise is presented in the paper. This integrated software is based on a custom system, the production department receives orders for production.

## Methodology

Product type's analysis and prediction is one of the popular topics in today's research works. However optimum design prediction in the textile management and apparel industry is not much common research as much as in conduct related to any other common industry or field. Out of the all optimization and prediction-based models slightly challenging this research area in apparel industry because, even though the same factory, they have to manufactured varieties of design products and they are printed in different colours, different sizes and it may have different shapes in different garments. Not only that but also day by day the market demand of those products may differ from several categories such as age, gender, trends, profession, social status etc. This is a dynamically changing area and time evolved from the historical records and data in the domain. So, Time series analysis comprises methods for analysing time series data in order to extract important and useful statistics and other features of the data. Time series forecasting is the application of a model to predict future values based on historically prior observed values.

After selecting a topic for the research, initial information about related works for this research that have collected already were gathered by the literature review as well as have done interviews with the professionals who are involved with this apparel design production domain. Since there aren't the same research works that have been done, related proposed systems in textile management and apparel market analysis studies researches have been reviewed. When reading various journal papers and conference papers there were so many approaches and techniques that have been developed to enhance the productivity and design analytical based systematic approaches. The analysis was done mainly to identify the current systems available with

the advantages and drawbacks on such systems and get the ideas & preferences of individuals within the society in related to men's shirt design types' prediction with Time series Analysis. And also during the requirement gathering the required information and data collection process will be done by taking real time data and actual information from interview the several of apparel factories and the employees (production strategy, designers, and sales team) and also questionnaires have sent among the general community.

According to the requirement gathering by means of conducted discussions and interviews it could summarize and conclude with important details such as most of the apparel companies are incurring losses and non-profitable products due to the remaining unsold items, One major reason to remain unsold items is that the designs are less attractive and also the lack of proper matching between demands and supply, It needs additional storage space to keep store leftover garments in the outlets and factories until it clears the discounted wardrobe, The entire apparel industry is going to having overall wastage Including cost, resources, time because of the garment designs that are manufactured haven't sold as the target, now a day the stock clearance sales are mostly arranged for men's shirts and it has a never lower marketplace demand for the men's shirts and gents fashion variations can be easily narrow down when compare with women's fashion categories. This wide range of data will help to identify the exact actual problem definition and as well as increase the performance of the time series data analysis. Each data mining technique has represented different accuracy levels and has purposed the technique depends on each model objective. Few of data mining techniques and Time series analysis and forecasting methods have been considered as follows. As the first step few data mining

techniques were studied. Usually, a time series is simply a series of data points ordered in time. In a time, series, time is often the independent variable and the target is usually to generate a forecast for the future. Below are the several famous ways to model a time series in order to create predictions.

Several data mining techniques were considered as follows.

#### A. Naïve Bayesian Classifier

This algorithm based on Bayes theorem which calculates probability by counting the frequency and combination of values. Here, small amount of training data for the relevant classification is required.

#### B. Decision Tree

It is one of a simple algorithm to divide up a large data collection into smaller sets of simple decision rules. Iterative Dichotomiser 3 (ID3) is an algorithm that is used often. The J48 decision tree is the implementation of the ID3 algorithm.

#### C. Genetic Algorithm (GA)

Optimized solutions and search problems are provided by using inheritance, mutation, selection, and crossover. There should be a genetic representation of the solution domain and a fitness function to evaluate the solutions.

#### D. Neural Networks (NN)

It is a tool that is used for complex classifications and clustering. NN is a parallel, distributed information processing structure. Processing elements or nodes and unidirectional signal channels or connections consist of NNs. There are two modes in ANN. One is activation transfer mode while the other one is learning mode.

Time Series models are used for a variety of reasons and variety of scenarios, predicting future outcomes, understanding past outcomes, making decisions, suggestions, and much more. These general goals of time

series modelling don't vary significantly from modelling cross-sectional or panel data. Time series analysis is a statistical technique that deals with time series data, or trend analysis. Time series data means that data is in a series of time periods or intervals. The data is considered in three types:

- 1.) Time series data: A set of observations on the values that a variable takes at different times.
- 2.) Cross-sectional data: Data of one or more variables, collected at the same point in time.
- 3.) Pooled data: A combination of time series data and cross-sectional data.

However, the techniques used in time series analysis and forecasting have been considered as followed.

**Moving average:** The moving average model is probably the naivest approach to time series modelling. This model simply states that the following observation is the mean of all past observations. Although simple, this model can be surprisingly good and is a good place to begin. Otherwise, the moving average can be used to identify interesting trends in the data. It can define a window to apply the moving average model to smooth the time series and highlight different trends.

**ARIMA Model:** This is the most important and widely used methods of forecasting. The time series analysis assumes that the underline time series is stationary or can make stationary by differencing it 1 or more times. This method is also known as the Box-Jenkins method. Using the ARIMA (auto-regressive, integrated, moving average) method is an iterative, exploratory, process intended to best-fit your time series observations by using three steps—identification, estimation, and diagnostic checking—in the process of building an adequate model for a time series. The auto-regressive component (AR) in ARIMA is designated as  $p$ , the integrated component

(I) as  $d$ , and moving average (MA) as  $q$ . The AR component represents the lingering effects of previous observations. There are several the Methods for Estimating ARIMA Models including Least squares nonlinear and linear regression, Maximum likelihood method, Generalized method of moments

**VAR Model:** Multivariate time series analysis provides information on the interactions and relationships of a group of time series variables. For example, a multivariate time series model can examine the interaction of temperature, wind speed, and precipitation. The most common multivariate time series model is the VARMA model. The VARMA model is analogous to the ARIMA model and contains an autoregressive component and a moving average component. In the multivariate model, the moving average component is unusual, and the most common case is the pure vector autoregression (VAR) model. The VAR model is a flexible model that has shown great success in prediction and has been used for political and structural analysis. The autoregressive vector model represents a group of dependent time series variables as combinations of their own past values and past values of the other variables in the group

**Naïve Method:** As the name suggests, under this method the forecasted values are just equal to the last observation.

**Seasonal Naïve Method:** We know that there is some seasonality in our data, when such kind of time series are available the Seasonal Naïve Method provides better forecasting accuracy than the simple Naïve method. Naïve methods are very useful in economic and financial data

### **Design and Implementation**

Under the design, mainly it must do the selecting the perfect analysis model type and designing the Time series model for the future prediction. It is considering how did evolve the most five categories of features in

shirt design according to the Time Series. Then after the analysis and model fitting then it can make predictions and the outcome will be display in the web application. This performs a non-linear functional mapping from the past observations of the time series to the future value. Mainly the design and implementation part have to be done under two basic phases; Analysis and forecasting time series data using the best appropriate model and create the model for the future predictions and secondly implement the web interface and dashboard visualization for display the final systematic output. Selected & determined what is the best model fit for the given dataset by using Akaike information criterion (AIC). It is a fined technique based on in-sample fit to estimate the likelihood of a model to predict/estimate the future values. In order to perform this AIC it has used the Likelihood Ratio Test with this formula;  $LRT = -2\ln(L) - m$ . By calculating and comparing the AIC scores of several possible models, could choose the one that is the best fit for this data; the one with fewer parameters has a lower AIC score and be the better-fit model. A good model is the one that has minimum AIC among all the other models. Finally, selected the best model fit: ARIMA model. In here the research domain is apparel industry. So, fashion trends and customer demands (emotions, choices) can be occurred seasonal changes, dynamic variations over the time. This data set is a time series data and it can be defined as a set of data that is made up of a sequence of data points taken at successive equally spaced points in time. And also by this research work I require to modelling time series data for forecasting (for predicting future points in the series)for the optimum best shirt design for future, in such a way that; a pattern of growth/decline in the data is accounted for (hence the auto-regressive part);the rate of change of the growth/decline in the data is accounted for (hence the integrated part);noise between consecutive time points

is accounted for (hence the moving average part) make future predictions. Finally, due to those reasons this research has decided to use ARIMA model with R for the time series analysis and design the model for further implementation of the tool. Furthermore when it considers this scenario and data set actually this is a class of models that evolve and explain a given time series based on its own past values, that is, its own lags and the lagged forecast errors, so that this model should be used to forecast future values. Not only that but also when it decides to fit an ARIMA model the first step in time series data modelling using R is to convert the available data into time series data format and data should be stationary. One of the major purposes to stationarize a time series is to be able to obtain meaningful sample statistics such as means, variances, and correlations with other variables. Such statistics are useful as descriptors of future behaviour only if the series is stationary.

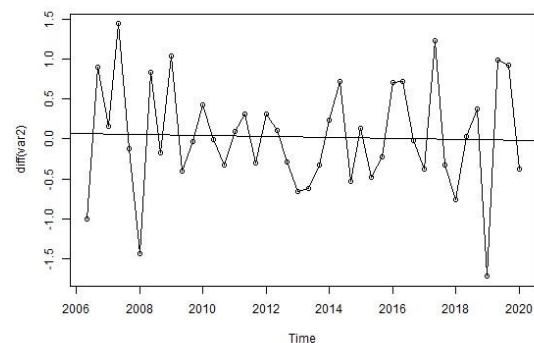

Figure 1: Time Series Graph of Actual Shirt Designs Data (15 years) Source: Output of fitted ARIMA model

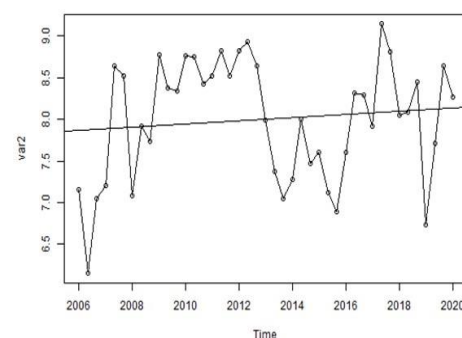

Figure 2: Differenced Series Source: Output of fitted ARIMA model

This is how the actual dataset looks like in Time Series plot. This suggests that the time series (actual) is not stationary and will require differencing to make it.

It is needed to do exploratory Analysis (EDA). Before performing any EDA on the data, it needs to understand the three components of a time series data: Trend, Seasonal, Cyclic.

The output will look like this:

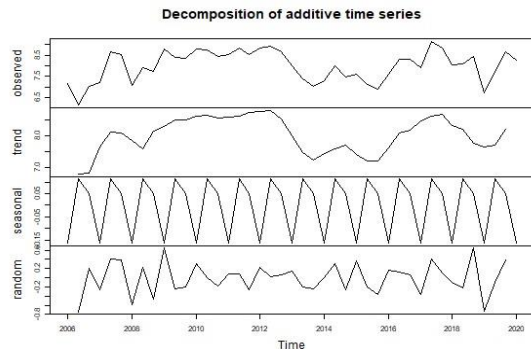

Figure 3: Differenced Series Source: Output of fitted ARIMA model

Here it gets 4 components:

Observed – the actual data plot

Trend – the overall upward or downward movement of the data points

Seasonal – any monthly/yearly pattern of the data points

Random – unexplainable part of the data

Observing these 4 graphs closely, we can find out if the data satisfies all the assumptions of ARIMA modelling, mainly, stationarity and seasonality. After that it can do ADF (Augmented Dickey-Fuller) Test for check the stationarity.

stationary, at least a difference order of 1 in some scenarios differencing order of 2 or more. The output looks like this:

Then finally, fit the model and start the forecasting.

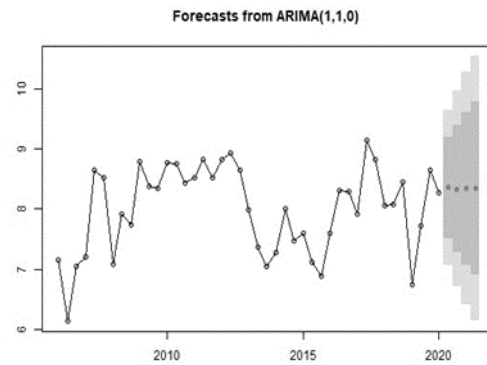

Figure 4: Forecast Plot of ARIMA (1,1,0) for next 4-time quarters Source: Output of fitted ARIMA model

The forecasts are shown in blue dots, with the 80% prediction intervals as a dark shaded area, and the 95% prediction intervals as a light shaded area. This is the overall process by which we can analyze time series data and forecast values from existing series using ARIMA. In here, have considered and gathered data of 15 years and divided a year into three quarters to analysis and forecasting the sales data of men’s shirt design.

### Findings & Analysis

Basic research problem evaluation and brief comparison and analysis of reviewed systems have been represented in this section. A survey on the shirt design demands and customer perspectives in textile industry was held as the initial finding of this research to analyses this research problem moreover and to determine and measure about the factors which may consider of the general public (customer) when buying a new shirt. This Google form questionnaire-based survey was collected 75 responses. It consisted of 12 different question tips on regarding apparel marketplace demand, buying patterns of customers as well as main features and design factors of a men’s shirt to identify for the respondents. As well as this questionnaire has concerned 10 different features of a men’s shirt under separate four questions to determine what are the most



prominent and for what has the highest consumer demand. According to the responses, respondents were related to every category of age groups under both gender types. The total mark of the questionnaire was assigned as 10 here since there are 10 different characteristics (features) of a shirt. When considering about total average of consideration of the features by the public generally it could conclude with 5 dominant features with the highest scores in order the percentages as below. The most considerable and dominant feature is Design with 53.3% of percentage as the highest scored, and then second main feature with 46.7% next higher score is Collar. Then the Sleeves with 26.7% percentage as the third. Finally, out of all those survey results and analysis it has concluded to narrow down the best and main feature for a optimum shirt is the Design in order to develop the final system.

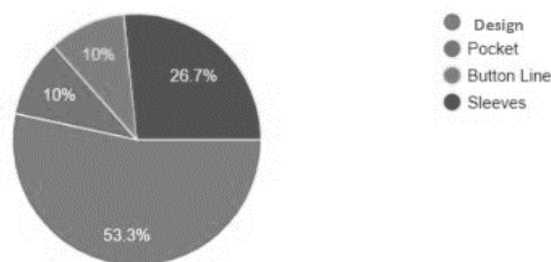

Figure 5. Pie charts of Shirt 's features selection Source: Questionnaire survey results

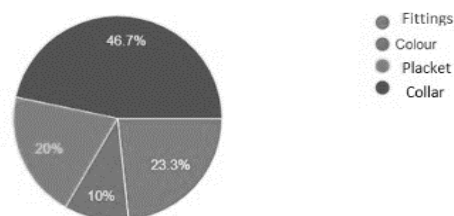

Figure 6. Pie charts of Shirt 's features selection Source: Questionnaire survey results

### Propose System

In order to obtain a proper forecasting and prediction of these optimum shirt design type, this research work will propose a web application that analysis and forecasts the dominant features of a shirt which has considered in the designing and production process. It will take historical records of features as input of the system. Time series analysis is forecasting or prediction of future values using the historical data. Then it will recognize the time series data pattern and will provide the optimal category type in each feature. Then by combining those five optimal features results it may give the final shirt design for the next year. The main expected output of this research is user-friendly, fast, accurate, secure, customize and quality model with web application and dashboard. Further, it can be commercialized by introducing to Google App Store. This system will analysis with a wide range of perspectives, a wide range of distributed data records from history, under different seasons, different features of shirts. The novelty of this solution is there are not developed systems to analysis and predict the men's shirt design types in previously and especially in Sri Lankan context. Besides, there are not adverse ethical impact or social impact and security threat from this web application. An accurate and successful analysis of these can support professionals (Designers, production teams) observe patterns and ensure the smooth functioning of the production process of the factory. The most important part of this time series analysis is forecasting or prediction of future shirt design type using the historical data. These predictions help in determining the future course of design the garments and give an approximate decision about how the market and customer demand will look a year from current for any individual or group of people. By the dashboard it can see that harnessing operational data and displaying it

within an easy-to-understand visual chart allows for greater efficiencies within the business platform. For most of the manufacturers, having a single source of statistical represented in a simple data visualization engages stakeholders. Dashboard tools enable increased information sharing across the business, making it easier to identify under performance or inefficiency in processes. With this enhanced visibility and knowledge, improvement opportunities can be more easily identified, encouraging change and integrate real-time manufacturing data. The final proposed solution can be summarized as the following figures.

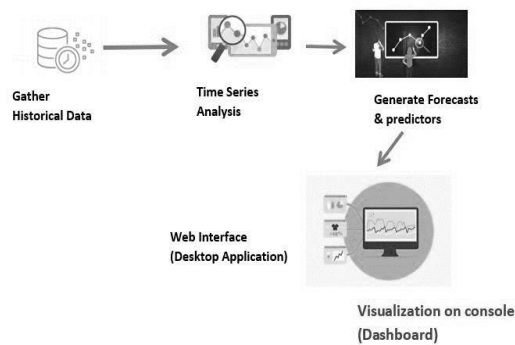

Figure 7. Methodology of the proposed solution Source: Questionnaire survey results

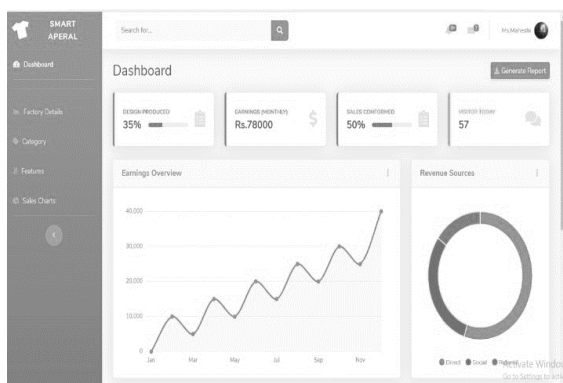

Figure 8. Dashboard interface of the proposed solution Source: Dashboard visualization

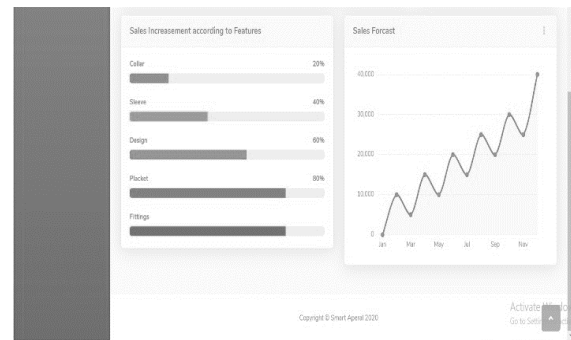

Figure 9. Dashboard interface of the proposed solution Source: Dashboard visualization

## Conclusion & Future Work

To create highly accurate, efficient prediction model of product (Men’s Shirt) designs in apparel industry, this paper has been reviewed analytical techniques including Traditional statistical methods and Artificial Intelligence and machine learning techniques. Even though there are so many various textile management and related garment market analytical classification researches have been done already, there aren't existing system to predict the optimum shirt design type on overall apparel production strategy specially in Sri Lanka. Therefore, this paper has been gathered some related researches for this review. In most of these existing related works, artificial neural networks, Big Data Analytics, Genetic search and Artificial Intelligence have been enhanced the accuracy of the statistical process control or apparel productivity management, here a new system has been proposed by using machine learning techniques with Time Series Analysis in order to forecasting dominant features of a shirt which can be effected according to the particular optimum design type in the apparel production. According to the literature review and overall related works the novelty can be emphasized as there are not developed systems to predict the design types of the any of garment product in the Apparel industry in previously. This will be provided efficient, effective and optimum prediction on the shirt

designs in terms of time series analysis and forecasting and minimize the leftovers in the factories and then the overall wastage will be minimized. Not only that but also this will make predictions & suppose the bestselling designs among the target consumer market. As further work the potential benefit of developing this optimum prediction model is increasing the productivity, profit and in parallelly reduces the overall wastage of the apparel products to improve consumer habits. Moreover, to provide a convenient way to predict the customer market demands for these textiles designs and improve the systematic optimum design prediction method for apparel industry. To gain a conclusion on such a research study area the information on the effectiveness of a systematic solution may have gathered by reviewing related works and existing systems and then its evaluation summary gave the points to be considered in developing such a model in future.

### Acknowledgment

Authors would like to express their great appreciation to all who supported to complete this review paper successfully.

### References

- AvoniGharde, "Influence of Factors on Clothing Sales and Its Future Trend: Regression Analysis and Time Series Forecast of Clothing Sales", *Journal of Textile and Apparel, Technology and Management*, Vol 10, Issue-2, pp.1-11,2016
- Choi, T.-M., Hui, C.-L. and Yu, Y. (2013) *Intelligent Fashion Forecasting Systems: Models and Applications*. Springer Science & Business Media.
- Giri, C. et al. (2019) 'Forecasting New Apparel Sales Using Deep Learning and Nonlinear Neural Network Regression', in 2019 International Conference on Engineering, Science, and Industrial Applications (ICESI). 2019 International Conference on Engineering, Science, and Industrial Applications (ICESI), Tokyo, Japan: IEEE, pp. 1-6. doi: 10.1109/ICESI.2019.8863024.
- Jananthan, R., Ameer, S. and Shiyamini, R. (2006) 'Comparative Study of Energy Assessment from Apparel Industries: The Context of Sri Lanka', in First International Conference on Industrial and Information Systems. First International Conference on Industrial and Information Systems, Sri Lanka: IEEE, pp. 217-220. doi: 10.1109/ICIIS.2006.365726.
- Li, X. et al. (2011) 'Applying GM (1,1) Model in China's Apparel Export Forecasting', in 2011 Fourth International Symposium on Computational Intelligence and Design. 2011 4th International Symposium on Computational Intelligence and Design (ISCID), Hangzhou, China: IEEE, pp. 245-247. doi: 10.1109/ISCID.2011.163.
- Moisanen, J. (no date) 'Demand forecasting in the apparel industry', p. 35.
- Prof S. K. Tyagi (ed.) (no date) *Data Mining Tools and Techniques to Manage the Textile Quality Control Data for Strategic Decision Making*.
- Raichurkar, P. and Ramachandran, M. (2015) 'Recent Trends and Developments in Textile Industry in India', 1(4), p. 4.
- Tien-you, W. (2010) 'Evaluating the influence of consumer preference in embroidery industry — An integrated forecasting model', in 2010 International Conference on Management Science & Engineering 17th Annual Conference Proceedings. 2010 International Conference on Management Science and Engineering (ICMSE), Melbourne, Australia: IEEE, pp. 97-103. doi: 10.1109/ICMSE.2010.5719790.
- Wong, W. K., Chan, C. K. and Ip, W. H. (2001) 'Application of fuzzy concept in the apparel industry', in Proceedings Joint 9th IFSA World Congress and 20th NAFIPS International Conference (Cat. No. 01TH8569). Joint 9th IFSA World Congress and 20th NAFIPS International Conference, Vancouver, BC, Canada: IEEE, pp. 2547-2550. doi: 10.1109/NAFIPS.2001.943623.

## Development of Automated Aquatic Taxi for Sri Lanka using Kansei Engineering Concept

A Kalhari#, N Wickramarathna, L Yapa, D Nandasena and LP Kalansooriya

*Faculty of Computing, General Sir John Kotelawala Defence University*

# achinikalhari97@gmail.com

**Abstract:** Transport is essential because it allows for contact, trade, and other types of people-to-people exchange. Transport plays a crucial role in economic development and civilization. When it comes to transportation media mainly, we are using air, water, and ground. As Sri Lankan people, very commonly, we are using ground roads to travel between cities. Most of the time, we apply waterways only to export and import between counties. We rarely use waterways within the country as our transport service. Now ground roads are too much busy because the number of vehicles is growing daily. So, we are introducing this new technology “Automated Aquatic Taxi (AAT)” service to use our natural waterways to transport in Sri Lanka. Our main aim is to reduce the ground road traffic and save the time of passengers with a new experience. As AAT authors are introducing a small or medium size, an enclosed boat is designed to automatically ferry passengers between and around cities. We are planning this to have also automated the manual control system. Automate allows “autonomous identification” and safe navigation around stationary objects in the water, swimmers, and any other obstacles. As Sri Lankan, we have a great history of waterways experiences. Our ancient people used boats and small barges to transport. So, this new step of AAT service will be a good experience in future aquatic transportation.

**Keywords:** Kansei Engineering, Aquatic Taxi, Transportation.

### Introduction

The Automated Aquatic Taxi (AAT) is a small enclosed boat designed automatically ferry the passengers around the city by using waterways in Sri Lanka (Anon., 2020). It has been the best alternative mode of transport, which offers better connectivity with roads and railways as it is congestion and pollution-free. Sri Lanka is a country which is enriched with numerous numbers of waterways all over the country by connecting one city to another. So, this AAT helps citizens of Sri Lanka to complete their daily necessities by travelling along with waterways by avoiding the usual traffic and it helps to increase the tourist attraction towards the country.

Figure 1 below represents all the state of waterways that are available in Sri Lanka and it shows how our country is rich with waterways. There are many rivers, lakes, reservoirs, and coastal water in the country.

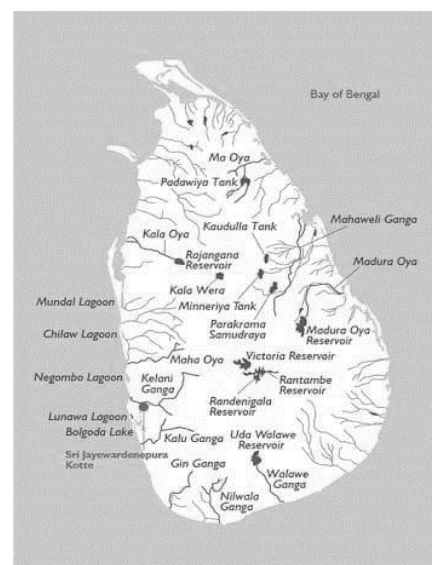

Figure1. State of Water Ways in Sri Lanka (Asia, n.d.)

Early Sri Lankans travelled across the rivers or waterways to fulfil their daily necessities by using boats or ferries. Considering the vast amount of literature pieces of evidence, it could be concluded that a well-established inland transport system has prevailed in the country from ancient times. However, AAT provides a significant influence on taking the inland transportation system of Sri Lanka to a different era. According to the latest WHO data published in 2017 road Traffic Accidents Deaths in Sri Lanka reached 3,554 or 2.80% of total deaths (SOMASUNDARASWARAN, 2006). So, this automatic aquatic taxi provides a great opportunity to reduce the rate of road accidents happens due to the heavy traffic as well. This AAT offers many benefits for its passengers, such as reduction of traffic, fewer crashes, and also it helps to reach the destination quicker than city roads. AAT becomes a major part of smart transportation as it reduces road traffic and road accidents (HKSK Hettikankanama, 2019). Smart transportation is a vital role of the smart city concept which is a popular concept among the city authorities all over the world. In the present number of international organizations consider the development of low carbon society (Sugeeswari Lekamge, 2013). This will be a solution as there is less pollution. AAT helps to increase the income of the government by increasing the tourist attraction for the cities

The development of our AAT is done primarily done by using Kansei Engineering concepts. Kansei Engineering is a branch of Ergonomics and it aims to produce a new product or to improve the social system based on the human emotional approach (Lévy, n.d.).

For the part of this AAT development, the focus is on the function of comfortable, safety, and attraction.

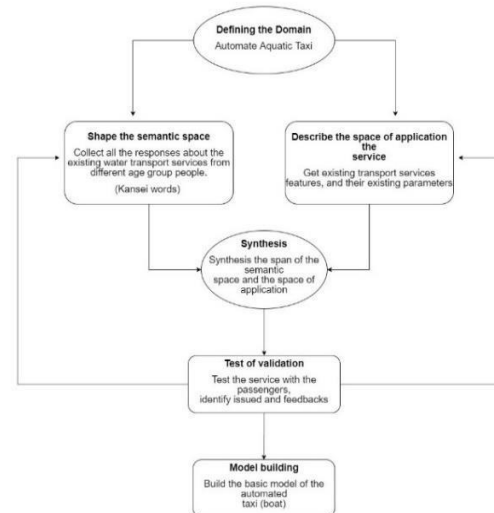

Figure 2. Kansei Engineering Methodology

The authors implemented this taxi according to the Kansei Engineering methodology. Figure 2 describes the process according to Kansei Engineering methodology.

The Kansei Engineering procedure applied in this research is the followings; (Schütte, 2002)

- (1) Draw images of the upcoming automated aquatic taxi,
- (2) Evaluate these designs based on KE method,
- (3) The evaluated data is analyzed by statistical analysis,
- (4) Using the results of design specifications derived from statistical analysis, the manufacturing of the basic model of the taxi is done.
- (5) Selected passengers/clients on different age levels and experiences evaluate the product. These data are analyzed again using statistical methods,
- (6) the designer group develops automated aquatic Taxi (AAT)

### 1.1 Features of the Product

- AAT is designed with automated controls, there is an option to manually control the taxi as well.

- Providing comfortable sailing for 8 people
- During the sail, this AAT rises above the water waves which minimizes pitching and gives passengers an absolute sense of comfort.
- The engine does not pollute the environment and runs almost silently.
- In addition to driving performances and comfort, the taxi impresses with an innovative steering wheel with a display, satellite navigation system and sonar which saves from underwater dangers
- Interior space can be transformed; furniture folds, side windows extend which creates a feeling of maximum spaciousness

## 1.2 Existing Systems

The need for accessible waterborne transit is likely to grow with the demand for tourist attractions, business travel and other development around bodies of water [1]. As a result, we thought to introduce the product Automated Aquatic taxi (AAT) with Kansei engineering concepts. The AAT is a small, enclosed boat designed to automatically ferry passengers around the city.

The AAT has planned to design with a unique look and colour schemes. While AAT is designed with automated controls, there is an option to manually control the craft. This has been added to open up the craft to tourists who might want to explore the city waterways on their own and for the Urbanities who needs to travel for their working places across the city without any traffic (Anon., n.d.) .

There are many existing systems for this product from the type of small to luxury aquatic vehicles. Following are some of them.

### 1.2.1 Capsule water taxi

Capsule water Taxies have been introduced for several years. The production has been begun by an Italian company the 2015 Jet Taxi is a new design from the company Jet

Capsule (Anon., n.d.) . Jet Taxis is weighing nearly 3.5 tons and it's powered by two diesel-fuelled engines, The special feature is the ecofriendliness of this craft (Anon., n.d.). To provide a quality travelling time for passengers it has designed in such a way that passengers protected from external temperatures, being protected against humidity, rain or sun, in any weather conditions. So, it's clear that this is a new way to conceive the "Water Mobility" (Anon., n.d.)

.

### 1.2.2 Futuristic hybrid boats

Most common travelling methods are cars, buses, trains and another land vehicle. But it is very rare to have water travelling experience. Futuristic hybrid boats are one of the best ways that a passenger can have such an experience. futuristic exterior that is completely a modern one, it also addresses the issue of environmental pollution by way of its hybrid capabilities (Anon., n.d.).

### 1.2.3 VT36 Speed Yacht is Luxury Aqua

The yacht was firstly invented by Dutch of the 14th century Since then yachts have been popular among people as an aquatic taxi, which provides a luxurious experience to passengers. There are many types of yachts available to make a lot of sense. The VT36 Speed Yacht isn't just a normal boat; it has a luxurious design with hardwood.

The types below are put into these categories: [8]

1. Express, Express Cruiser, Cruiser, Sports Cruiser
2. Flybridge, Sedan, Sedan Bridge, Sport Bridge
3. Motor Yacht, Pilothouse Motor Yacht, Cockpit Motor Yacht, Sky lounge
4. Tri-Deck, Mega Yacht
5. Sportfish, Express Sportfish, Flybridge Sportfish, Convertible

### 1.2.4 NYC Water Taxi

This water taxi is a New York Water Taxi and it is 12 feet high. It offers passengers to wonderful sightseeing through the East River and Hudson River (Anon., n.d.) .

## Methodology

### 2.1 Materials and Methods

Kansei Engineering method includes a list of steps. Based on the statistical procedure, the first step is to select suitable Kansei words, usually gained through literature. The second step is the Kansei evaluation experiment, where participants will rate the design samples using the Kansei words, which obtained from the first stage with a Semantic Differential (SD) scale. The last step or simply the third step is about the statistical procedure which analyses the relationship between Kansei words and the product design elements

### 2.2. Collection of Kansei words

Table 1 shows the 20 words that have been collected and gathered to form a new database for an automated aquatic taxi.

*Table 1: Selected Kansei words*

Modern	Comfortable	Stylish	Creative
Strong	Convenient	Simple	Complex
Elegant	Functional	Cheap	Durable
Friendly	Impressive	Neat	Attractive
Average	Expensive	Safety	Exclusive

It was necessary to collect some of the words (Kansei words) that might reflect the needs of the customer and that relate to the product which will help us in thinking about the proposals for a new product suitable to the needs of the customer.

2.3. Semantic Differential (SD) scale The semantic differential can be known as a kind of a rating scale which is designed to measure the connotative meaning of objects, concepts, and events. The connotations can be used to determine the attitude towards the given object, concept or event or is a standard visual analogue scale and a 7-grade-Likert scale. Authors have used 7-grade-Likert rather than 5- grade-likert as it is more accurate and easy to use. And also we can get a better idea of the respondent's preference. To ensure that the word was properly understood, the extremes on the opposite sides of the scales were symbolized by (very much) and (not at all).

We weight every word to determine its importance, then select the most important words to be used in the questionnaire. Thirty-five participants were interviewed and asked to answer the SD scale questionnaire

### 2.4. Importance weighting

In this study, authors use SD scale to measure the importance of each word and choose the most important words which have high grades, also we calculate the weight of each word to determine the importance of the word.

The weight = (the total grades of the word) / (7\*no of participant).

Table 2 represents the grade of Kansei words and importance weighting.

After selecting the words that have the highest degrees and the highest weights. We collect all selected words in a table. Table 3 shows that the six words that have the highest grade are comfortable, convenient, attractive, functional, safety, and durable.

Table 2: Grade and weighting of Kansei words

Kansei Word	Grade	Weight
Modern	144	0.58775
Strong	129	0.52653
Expensive	102	0.41632
Attractive	181	0.73877
Complex	82	0.33469
Convenient	173	0.70612
Friendly	60	0.24489
Functional	177	0.72244
Comfortable	190	0.77551
Exclusive	132	0.53877
Simple	100	0.40816
Stylish	151	0.61632
Durable	167	0.68163
Neat	78	0.31836
Safety	189	0.77142
Impressive	92	0.37551
Creative	113	0.46122
Elegant	120	0.48979
Cheap	103	0.42040

Table 3: The meaning table

Kansei Words	Meaning
Comfortable	Providing physical well-being or relief
Convenient	Fitting in well with a person's needs
Attractive	Pleasing or appealing to the senses
Durable	Able to withstand wear, pressure or damage hardwearing
Functional	Relating to how something works or operates
Safety	Condition of being protected from or unlikely to cause danger, risk, or injury

The chosen elements (characteristics) related to the most appropriate word of Kansei words by brainstorming. These words & elements are combined in a questionnaire. Each question must be involved some requirements of the product related to Kansei words which must be suitable for this requirement

In this study, the questionnaire includes three sections, two sections (functional and dysfunctional) to check the AAT design (Taxi shape, Taxi material, Taxi mechanism). The number of questions is thirty-two divided to sixteen functional questions and sixteen dysfunctional questions.

### Analysis of Questionnaire Results

#### 3.1 AAT shape analysis

The participants were asked to choose among (capsule, hexagonal, and squared). Due to the result of the total satisfaction factor, it's clear that (Capsule-shape) is the most satisfactory. So, the new design should consider the shape to be a capsule shape. Capsule-shape of the taxi helps to reduce the resistance that occurred by the water by helping taxi to move faster by using less power.

#### 3.2 AAT material analysis

Authors have asked whether it is better aluminium, carbon fibre or steel. Due to the result of the total satisfaction factor, it's clear that carbon fibre is the most satisfactory. So, the new design should consider the taxi material to be made of carbon fibre material. Carbon fibre is the ideal material for manufacture the body of the taxi since carbon fibre is stronger, stiffer and lighter than steel and aluminium.

#### 3.3. AAT mechanism analysis

In this section, the participants were asked to comment on the taxi's engine, windows, seats, lighting and electrical systems, security systems and navigation systems.



## 2.5. Relating KE with engineering characteristics

Respondents have to select the following facts.

- Single engine or dual engine
- Transparent side window or transparent roof window
- Limo seat or single seat
- Set door locks automatically or set door manually
- Autopilot navigation or manual navigation

We have gathered data about the general idea about the aquatic taxi, how it affects to Sri Lanka, preference of the community to new technology, benefits, drawbacks and many other things also.

From this survey authors, the main aim is not only implementing this taxi but also introduce this new technology to Sri Lanka and give this marvellous experience to the Sri Lankan. So, they have asked several questions to get to know their likes and dislikes.

## 3.4 Pairwise comparison of opinion about AAT

Each respondent in the questionnaire is allowed to make their general opinion about aquatic taxi technology whether it is “Strongly Agree”, “Agree”, “Somewhat Agree”, “neutral”, “Somewhat Disagree”, “Disagree” or “Strongly Disagree”. Most of the respondent have a positive attitude towards this.

According to data, we gathered “Agree” and “Somewhat Agree” are the factors rated highly with generalized weights of 50.6%, 30.9% respectively.

## 3.5 Factors considered implementing AAT

According to the survey results, we found out that 84.9% of the people like that taxi would implement that can operate manually.

A small amount of number 15.1% people like fully automate. They like AAT which can process manually also.

We can clearly say according to the data we gather many people think attractiveness and comfortable of this aquatic taxi. According to our knowledge, the reason is as it is a new experience to Sri Lankan People. When some people highly accept the safety of the taxi some people don't care about safety

An average amount of respondents believe comfortability, safety and attractiveness of this new proposed system are sufficient to start this project.

## 3.6 Design

After following the procedure described above, we created the following design according to the ethical facts and the respondents' suggestions and government project in 2017 (Megapolis, April 2017). Figure 3 shows the sketch of the design of AAT. We wish to build it with more features as shown in figure 4 as in a way it increases the safety of passengers, travelling speed, reliability, comfortability and the outer appearance as well.

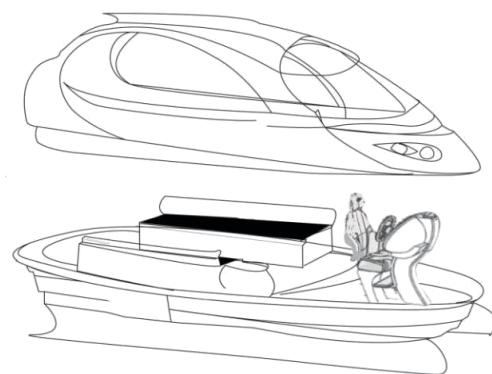

Figure 3: Sketch of the designed AAT

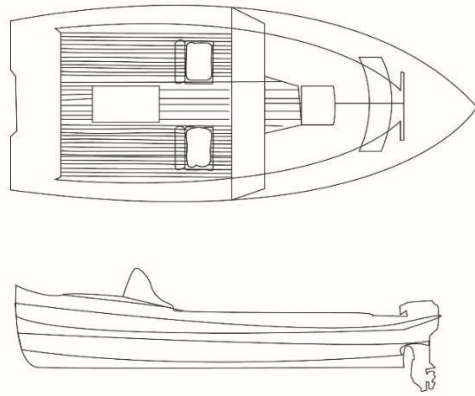

Figure 4: The new automated aquatic taxi design

It is a capsule shape which is easy to go through the water. It is fully covered design to improve the safety of passengers. Though it is automated there is a separate section where a person can manually control the boat in an emergency case. This is a medium-size boat which is designed for 4-6 passengers. So there are two separate seats. Basic parts like lights, front window wipers are included. To get the attraction transparent glass have been added end to the bottom.

### 3.7 Major obstacles in implementing AAT

Lack of infrastructure and high initial cost are two major problems we have to face when implementing such kind of project in Sri Lanka. The investors must discuss these issues with relevant government authorities. Only 34.8% of people who contributed to this survey believe that the government having positive feedback towards such kind of projects.

56.3% of respondents do not have an idea or previous knowledge about how they can use aquatic taxi for their travelling purposes. So, awareness programs like advertisements on media must be conducted before launching this project.

39.8% of people do not live near any waterway or else pass any waterway in daily

travelling. For these kinds of people cannot use this transportation method. Only 60.2% of people are living near or else pass any waterway in daily travelling.

Another problem we have identified is backwardness in adapting to new trends. Only 52.6% of people think it will suit. 6.4% of people do not even like to test it. This is not a good situation.

Abnormal fear for water is also a problem. 24.1% nearly (1/4) of people fear for water and 14.5% does not have confidence. Only 61.4% have the confidence to travel through this system. Another point is whether the people who use these water inlets as their livelihood and the people who live adjoining with these water inlets will allow making this project happen. Another thing that this project should be done without harming the natural environment.

### 3.8 Benefits of AAT

An excellent number of respondents believe that the Reduction of traffic results in fewer crashes. Moreover, AAT helps to reach the relevant destination quicker than city roads by avoiding traffic. AAT provides the main source of income for the government of Sri Lanka by increasing tourist attraction towards the country (Lévy, n.d.). AAT provides safe rides for the riders who want to handle the taxi manually as well as automatically. This vehicle provides super luxury comfortable sailing for about 8 members. AAT is a super environmentally friendly vehicle which does not cause air pollution like ordinary vehicles in the city roads. AAT is fast and it gives a unique experience for its riders.

### Discussion and Conclusion

There are many automated vehicles on the roads and in the sky. What about the water? Is it impossible in the water?

Actually No. AAT will be the new trend in the transport system. Already using ships, boats

for export, import and fishing. But when it comes to Sri Lanka, we rarely use our natural waterways for transport service. Sri Lanka has a wide range of rivers and waterways. The number of vehicles in the world as well as Sri Lanka, has increased within a short period. Because of that government must increase the facilities of the roads and they have to build more roads like highways. When it comes to building new roads, it is a big process and it needs more money. Sometimes they may have to remove hundreds of trees. When to consider the design of the taxi; the main shape of the taxi is based on capsule shape since capsule shape helps taxi to move faster by consuming less power. The material used to manufacture the body of the taxi was carbon fibre since carbon fibre is stronger, stiffer and lighter than steel or aluminium. Authors are introducing this new technology AAT to use the existing waterways of Sri Lanka. Furthermore, we can distribute this service as the government and private sectors. This will be a good opportunity to get the attraction of foreigners to our country. Automate can work day and night in all types of weather. With the latest technologies, automated water taxis may have the ability to “see in the dark”. Onboard cameras and lidar sensors spot and avoid other boats and floating debris. Near future, we can improve these automated aquatic taxis into cargo boat service. When it comes to a new idea, there are both pros and cons. So, this service may not be able to apply all over the country. Because we may not find suitable waterways all over the cities. When it comes to a new idea, there are both pros and cons. Less cost of maintenance is a major benefit of water transportation when it comes to rail and road transport the maintenance cost is quite high but the maintenance cost of water transport is quite less. AAT will be beneficial during natural calamities like flood and rains when rail and road transport is disrupted, relief operations can be operated through water

transport. AAT will be a major source of tourist attraction in the next few years (Mehta, n.d.).

Slow speed is one of the disadvantages in aquatic taxis, it is a slow means of transport. Failure of monsoon results into fall in the water level of rivers making navigation difficult. At the same time, water transport is riskier as compared to other means because there is always a danger of sinking. Waterways and canals can't be worked for transportation during the time as water may freeze during winter or water level may go particularly down during summer.

Also, there is a small percentage of passengers who have aquaphobia (abnormally afraid of water) (Anon., n.d.) Like all computer systems, automated water taxis would programme to run and use manual control system also. So, it will help to avoid these issues.

## References

- Anon., 2020. Automated Aquatic Taxi. [Online] Available at: <https://www.trendhunter.com/trends/cal-craven>
- Anon., n.d. 13 Example of aquatic Taxi. [Online] Available at: <https://www.trendhunter.com/slideshow/waterborn-e-transport>
- Anon., n.d. Jet Capsule Mobility. [Online] Available at: <http://www.jetcapsule.it/>
- Anon., n.d. Managing the Fear of Water. [Online] Available at: <https://www.healthline.com/health/aquaphobia#treatment>
- Anon., n.d. The water craft Journal. [Online] Available at: <https://watercraftjournal.com/>
- Anon., n.d. Travel Away. [Online] Available at: <https://travelaway.me/world-taxis/>
- Asia, W.-W. E. P. i., n.d. State of Water Environmental Issues. [Online] Available at: <http://www.wepadb.net/policies/state/srilanka/overview.htm>
- HKSK Hettikankanama, S. V., 2019. Integrating Smart Transportation System for a Proposed Smart. Colombo, s.n.
- Lévy, P., n.d. Beyond Kansei Engineering. International Journal of Design. Megapolis, M. o., April 2017. Inland Water Based Transport Project, Western Province Sri Lanka: s.n.
- Mehta, P., n.d. Advantages

and Disadvantages of water Transport. [Online] Available at: <https://www.economicdiscussion.net/articles/advantages-and-disadvantages-of-water-transport/2185> Schütte, S., 2002. Designing Feeling into Products. Sweden: Division of Quality and Human Systems Engineering. SOMASUNDARASWARAN, A., 2006. Accident Statistics In Sri Lanka, s.l.: IATSS RESEARCH . Sugeeswari Lekamge, A. M., 2013. Developing a Smart City Model that Ensures the Optimum Utilization of Existing Resources in Cities of All Sizes. Tokyo, Japan, s.n.

Faculty of Computing. This author was awarded the Doctor of Engineering of Information Science and Control Engineering by Nagaoka University of Technology, Japan. The main research interests include Human-Computer Interaction, Affective Computing, Ambient Biomedical Engineering, Hologram Technology, and Distance Learning

### Author Biographies



Achini Kalhari is currently a BSc. Computer Science undergraduate at the Department of Computer Science, Faculty of Computing, in the University of General Sir John Kotelawala Defense University



Lithmi Yapa is currently a BSc. Software Engineering undergraduate at the Department of Computer Science, Faculty of Computing, in the University of General Sir John Kotelawala Defense University



Nipuni Wickramarathna is currently a BSc. Computer Engineering undergraduate at the Department of Computer Engineering, Faculty of Computing, in the University of General Sir John Kotelawala Defense University



Dilshan Nandasena is currently a BSc. Software Engineering undergraduate at the Department of Computer Science, Faculty of Computing, in the University of General Sir John Kotelawala Defense University.



Dr Pradeep Kalansooriya is the Head of the Department of Computer Science, Faculty of Computing, General Sir John Kotelawala Defense University, and a Senior Lecturer of the

## The Future Directions of the Learning Management System: A Review

JMHK Jayalath<sup>#</sup>, WAN Malshani, PBD Ariyaratna, NGC Ranahansani and WAAM Wanniarachchi

*Department of Information Technology, Faculty of Computing, General Sir John Kotelawala Defence University*

<sup>#</sup> hesharajayalath@gmail.com

**Abstract:** Education is the most powerful weapon for a person's life which will never be stolen throughout the journey of one's own life. Being educated will never be perishable as it is a lifetime validity given for one's persona career. As a consequence, it is obvious that education plays a vital role. In the process of being educated, higher education took a prominent place as it is one of the life indicators. A serious and a growing problem was identified in the higher education where geographical barriers, venue, time hinders the higher education with the passage of time. As a solution to all these problems, current educational trends have influenced the higher education to enhance learning process more technologically.

This review intended to carry out a detailed analysis on Learning Management Systems and find out the untouched areas or else the points that won't be talked about and still not yet developed up to a good level. The review is conducted with the objective of investigating the success of LMS, features of existing LMS, how the educational institutions make use of new technology and what are the areas that need further attention in future or in other words what are the features that should be developed further with the aim of looking more advancement. Identifying the available spaces for further enhancement or the development is the main aim of this review paper and this study investigates more about Learning Management System in advance

**Key Words:** Education, LMS, Future, Technology, Development, LXP

### Introduction

Education plays a vital role by means of conditioning the individual in some special manner and also education can be recognized as a true sense in which it is useful in maturing an individual as well as to be free and to flower greatly. The highest function of education is to bring an individual who has the capacity to deal with life matters as a whole. From year to year, the evolution of technology becomes the steppingstone for our future career. In other words, the digital environment is capable of reshaping our world with a new mood and along with this development; education too touches with this evolving technology which has resulted into a range of benefits and opportunities. Among these, LMS does a huge role in the field of higher education. LMS stands for the abbreviation; Learning Management System. Oxford dictionary says that "LMS is a software system for managing training and educating using the internet." It is a concept that we experience now a days as a result in the advancement of information and technology. Since LMS is associated with higher education the role of lecturers, trainers and other resource persons are decentralized in the hands of LMS. It is important to note that lecturers as well as students faced many a problem before introducing the concept of LMS and therefore everyone felt much inconvenience as a result.

By eradicating all these barriers, with the implementation of LMS it acts as an online portal as it is the bridge of connecting students and lecturers. The lecturer's trainees and other resource persons do not have to put much effort on explaining the subject matters and they need not to spend more time on the same purpose as the LMS has made both these tasks convenient. Since this is a not singleton process and being a two-way process; both lecturers and students can share what they feel and understand in which lecturers are responsible of distributing their knowledge, lecture notes and other materials and students being the receivers of this online teaching have the opportunity of giving their opinions. Additionally, the students who are accessing the LMS; irrespective of the venue and time they are, owing to the attractive, easy going modes of learning through the technological suits without wasting time on collecting written forms of lecturers. With this quick shift from current traditional environment to online educational environment has been identified as a great opportunity for making the space to think in multiple ways and also to receive immediate response throughout the day without any specific time and place. The surprise is that, all coursework is conducted exclusively online. In a nutshell, LMS is rendering a remarkable service in the field of higher education and training purposes to get the work done in a jiffy.

No matter how advanced the technology is, there are many areas where LMS needs to improve. We have seen this after a detailed analysis of about 30 research papers and in the end, we can conclude that in the near future, LMS will continue to develop and become even more advanced in the field of higher education. So, we have decided to do a review by identifying areas of improvement and looking more closely at them in a more analytical manner. As a conclusion, this review will discuss more about the

shortcomings of LMS and also after identifying, discuss the reforms that need to be developed and what can be improved with the aim of bringing LMS into the arena.

### **Literature Review**

This study would help researchers involved in development of e-learning based LMS. develop a cloud based learning management system (CLMS) which can incorporate all the features discussed in previous section and new features like automatic assignment evaluation with the integration of plagiarism detector and keyword matching, web based virtual workshop management and single sign on. And also it is quite evident that the cloud based system would help the educational institutes or Universities to share and disseminate knowledge among students, teachers and researchers. (Patel et al., 2013) Some researchers attempt to discover the essential usability factors, implementation and adoption issues and the barriers and enablers within the LMS domain, primarily in workplace settings. To achieve these aims, a review of the literature has been carried out by considering 23 research articles published in between 2014 to 2018. The discussion highlighted current issues in the field, as well as gaps and possibilities for further research. Usability is a measure of the degree to which users can use a product or system to effectively, efficiently, and satisfactorily achieve their objectives; this means that users will be trained quickly and efficiently if the degree of usability of LMS is high. (Sabharwal et al., 2019)

Learning Management Systems used in Sri Lankan universities, and evaluates its usability using some predefined usability standards. In addition it measures the effectiveness of LMS by testing the Learning Management Systems. The findings and result of this study as well as the testing are discussed and presented. (Kommerell & Klein, 1986) Implementing learning

management system is large decision for a higher education institution. A large consideration of this decision is the financial cost. Most vendors offer a robust Learning Management System (LMS) product but require upfront costs and yearly site licenses. These costs may be especially cost prohibitive if it is a single department or even a small university which is considering purchasing the learning management system. To overcome these issues, some schools have developed their own learning management open source system, such as Open USS. Institution should consider exactly what objectives they wish to achieve through the LMS before acquiring a system. In this research paper researcher suggest the following factors as the most important consideration when selecting a LMS: organizational goals and objectives, technical specification and support, design specifications, clear and user friendly graphical interface, well designed course repository, course administration capability, capability of interaction among users, evaluation and feedback, student's profile, and pedagogy.(Grob et al., 2004) Almost all government universities in Sri Lanka have implemented LMS for students to make their learning process interactive and engaging. These higher educational institutions have made considerable amount of investments in terms of finance and other resources, but the benefits enjoyed by these institutions and student are far below expectations unless the usage of such systems are made compulsory. Therefore, although many studies have been conducted overseas, it is of high recognition that a study is very much needed to understand the reason for low usage by students in Sri Lankan free education context. (Fathima Rashida et al., 2018) Perceived ease of use (PEU) has a significant impact on perceived usefulness (PU), as suggested by Technology Acceptance model (TAM) theory. They have identified that both (PEU) & (PU) also have positive effect on

behavioral intention to use. They have said that, LMS is an essential tool for university students as not they can keep updated with their course work, but get instant notifications pertaining to their daily assignment. (Adzharuddin, 2013) benefits of online learning have categorized into three aspects (Pedagogical improvement, increase access & flexibility & cost effectiveness) and they have told that functions of LMS have divided into four major parts. They are Stakeholders functionality, management of information, Assessment. Course management purely depend on the instructor but information exchange gives opportunity to both learner & instructor. (Chen & Almunawar, 2019) Researchers have used quantitative approach in order to test hypothesis, self-administered questionnaire is disseminated to the LMS adopters. They have distributed a total of 50 questionnaires & summarized by demographic profile & descriptive statistics of the respondents. They have used responses like strongly agree, agree, neutral, disagree & strongly disagree. They have examined student's perspective by conducting a correlation matrix between student's perspectives & student's adoption of LMS. (Murshitha & Wickramarachchi, 2016) instructors struggled with many tasks before the advent of LMS. Teachers were required to undertake many additional responsibilities besides teaching, such as tracking student's projects, grading, responding to queries etc. even universities suffered before the invention of the LMS. Universities had lot of admission & registration issues. Institute had to respond to all these needs. So, they choosed LMS as the best solution. LMS provide a great number of tools that help students to learn more effectively, & school to manage more powerfully (Alshalawi, 2013) . LUCT (Limkokwing University of creative technology in Malaysia.) have studied all the undergraduate students, who were in

semester three or above, that using LMS their education. They have distributed 520 questionnaires, the researchers managed to get a return of 465 useable questionnaires. Their data collection method was drop-and-collect survey method. They personally delivering the survey instrument & later collecting questionnaire either directly from the target respondent or indirectly via a gatekeeper.(Jafari et al., 2016) In a research paper, they have done a survey by using two main areas of inquiry, faculty usage & faculty perceptions of the LMS. Here, focused on what faculty use in LMS to aid their students in not only gaining knowledge, but also in engaging them in the course & area of focus. A survey was developed using zoomerang survey software which contained 39 questions. Share opinions about what they liked most & least about the learning management system, how their experience using the LMS in instruction could be improved, & finally, in what ways they would like to use the LMS more effectively.(Little-Wiles et al., 2012) This paper reviews on what impact LMS has made on students and how effectively LMS has influenced students on their academic activities. Key features may include student self-service, self-registration, instructor-led training, skill group management, user notifications and deadlines, manager hierarchies, wait-list management. The functionalities of LMS are electronic distribution of course syllabus, grades and teachersfeedback to students, ability to post hyperlinks to websites and forum for the exchange of ideas.(C & Patil, 2012) Learning management systems are designed to gather both the faculty and their institutions with the organization. The purpose of this study was to better understand how the faculty at one urban institution viewed and made use of their mandated learning management system. The results can be beneficial in improving training, support, and usage of LMSs at multiple institutions. Online courses area

was considered in this survey. This research try to highlight the issues and concerns facultyhave toward the use of their LMS. (Little-Wiles et al., 2012) Cloud- based LMSs are usually proprietary systems where the vendor packages the system functionality with the online hosting of the client's data and then charges a fee for the service based on the number of users accessing the LMS site. Research paper mentioned on Future versions of LMSs. They are Cloud-Like Functionality, Adaptive Learning, Micro learning with LMSs Connected Devices, Analytical Tools, Social Capabilities and Gamification. (Turnbull et al., 2020) Learning Management Systems (LMS) is the main component for distance education to be carried out effectively and distantly. The aim of this study is to identify trends in studies published in popular journals on learning management systems between 2010 and 2014 for academicians who aim to conduct a study related with learning management systems. For this research data were retrieved from the electronic database and data were entered into SPSS program. It was also revealed that Moodle LMS's as open source and Blackboard (WebCT) as commercial are the mostly used LMS's in the studies. Results on usage aims of LMS's indicate that studies are mostly conducted to test the developed LMS's and measure the perceptions and attitudes of learners. (Soykan & Şimşek, 2017)

### **Methodology**

The objective of this research paper is to analyze the future directions of the Learning Management System. We gathered information through published research studies on the Learning Management Systems.

Regarding the first step, the subject of this review involves "Future directions of learning management system" and the question that guides the development of this integrative review is what will be the state of



the LMS of future in e-learning management? In the second step, establish the identification of contents of the research papers which we read on the studies. As the third step, we categorized the study analysis and then we tried to capture new innovation features of Learning Management System. In the fourth step interpret the results of analysis. In the final stage, present of the review and Synthesis of information which we analyzed in research.

In this context, it helped to recognize the development of LMS studies on e-learning managing over time and it thus allowed to envision new possibilities for research.

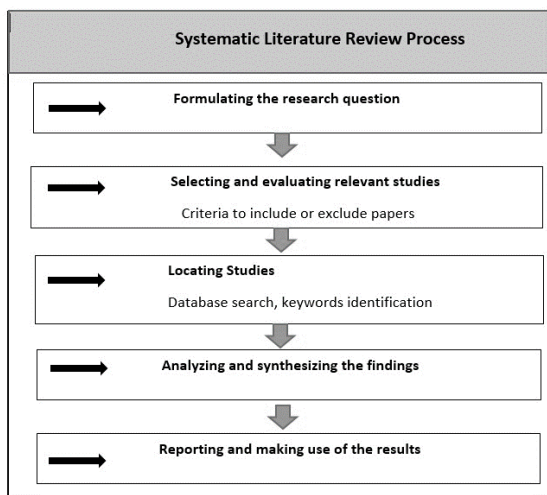

Figure 1. Review Process

### Future Enhancements

In this review; the main aim is to provide some future recommendations in which we can develop the Learning Management Systems more and more. Learning Management System is a useful tool in the field of higher education and by developing its features and facilities further; we will be able to obtain many advantages. Therefore, paying attention to the section of ‘future enhancement’ took a prominent place. One of the important points to ponder on are as follows.

Adapting to multi-channel learning styles. (In 2019/2020 rather than Traditional Instructor led training, In the Job Training is

important. When it comes to applicability of learning and training, multi-channel learning allows not only access to anytime-anywhere learning but also faster application of skills learned or upgraded. Instructors can deliver a vivid service by using the available facilities such as video conferencing, audio scripts. LXP is another developed tool than the famous LMS and shifting to LXP from LMS, will provide more advantages. For example, LMS is a platform which is controlled by the administrators and they decide the course sequence, learning path. But when it comes to the topic of LXP, it is an open-ended discovery platform where we can create our own goals and can determine own learning path as well. LXPs provide is the operational value to the organization with micro-level reporting and the opportunity for deep analytics, creating meaningful impact for both the learner and the organization. Additionally, LXPs provide learners with a collaborative, self-driven journey that is engaging and well-circulated among peers and fellow learners. Skip also rightly mentions that, “Today’s learners want learning that is available on the go, modality agnostic and quick to consume.” One of the biggest benefits of LXPs is their platform fluidity and this ties in with the trend of multi-channel content. Moreover, with improved technology and connectivity, experts who were once unreachable are now available on-demand and can create value for employees/learners.

The capacity of students grabbing the knowledge is different to one another. Some may understand the matters at once, but some may fail to understand it. LMS doesn’t consider this area and it will be better a necessary method is developed to match the level of understanding of the students along with the learning path.

According to a survey reported in The Daily, differences by income, education and age exist in the use of internet. Therefore, though

LMS is common to all university students; there may be some problems for the undergraduates in accessing the LMS. So, if there is a new way to make the undergraduates inform about new lessons uploaded and new assignments given at the moment when it is uploaded, the difference which exists in the use of the internet may not be a major issue.

The internet is mainly chosen by university students as a source of information because of its swiftness in delivering information, and also the potential it gives them to connect with other peers from around the globe for the purpose of sharing information. When accessing the LMS using the internet the students may not do what they wanted to do and instead of that they may involve in certain other activities like use social media and all. This can be avoided if there is a certain method to use internet only for the access of LMS during Lecture hours. So, then students will have no any other option other than engage in their studies.

Threaded discussions, forums, video conferencing are the main features of LMS. But many instructors restrict themselves to uploading course materials to the course web site. If there is a systematic method to upload the lecture notes at the moment when it is taught by the particular lecturer; the students won't feel any inconvenience at all. And also, until the instructor uploads the lecture not a message will be sent for the particular lecture and also an email will be sent.

LMS is seen to be compatible with traditional education as both of them are based on a lecturer centered approach.

Most content within a LMS is not available to the outside world, and also it is often unavailable to learners just after they have completed their course. This clearly tells us that LMS doesn't support lifetime learning

and this is another area which has not been touched still.

Artificial Intelligence is also set to start having an impact in the LMS space. By automatically evaluating a learner's understanding of a concept and adjusting their learning pathway. It is a common truth that Learning Management Systems are subjected to changes rapidly where it is hyper connected and trend sensitive. Changes in format and processes mean that lecturers need to pay full attention to the needs of the students in the context of educational needs. Having flexible platform managed by the Learning and Development; it will be convenient to add resources etc.

### **Result and Discussion**

In this section the fourth step of the integrative review is shown, interpret the results for analysis. We read 30 research papers on future directions Learning Management Systems. After reading the articles, some future developments were highlighted in researches. Among them, we selected four features which majority of researchers analyzed. 20% researchers have discussed the LXP tool, 15% discussed on Artificial Intelligence, 15% of researches have highlighted on Vivid Service (video conferencing, audio scripts) and 10% have discussed on adopting to multi-channel learning style. The results which we analyzed are presented in graph.

This graph clearly proves the fact that; LMS can be developed further by using LXP, AI, vivid service and multi-channel. LXP which is known as learning experience platforms provide intuitive learning experience. LXP can be used to make a flexible and scalable learning track for users. When we are using LXP with LMS; the learners will be motivated and encouraged to memorize about their past activities or what they have come across and also administrators have the chance of shaping the learner's learning experience

with an LXP. LXP is a software which is highly customized, user controlled and therefore by integrating LXP with LMS; AI helps in eLearning development by classifying the elements of the content. An AI-powered LMS tool can sift through all the massive content and efficiently identifies suitable content. It will be convenient if there is a flexible online LMS for multi-channel learning. Think of a flexible learning management system allows a learner to participate in learning activities from any device, in a variety of formats. So by using multi-channel LMS; it will provide more advantages and it will be more technological and of highest flexibility.

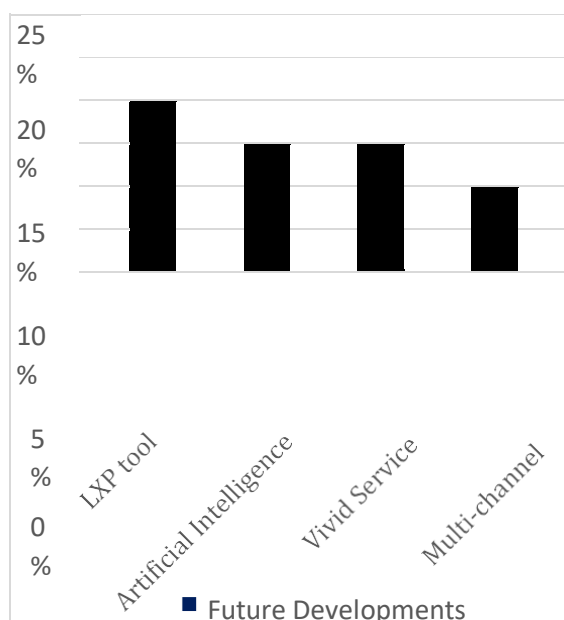

Figure 02 summary of analysis Source: (Author)

### Conclusion

After thoroughly analyzing the facts that contain in many a research papers, we come up with the idea that Learning Management Systems are very important, and it plays a huge role for the success in the field of higher education. Though it looks like a perfect tool at glance, when analyzing or when going through these papers broadly, it is crystal clear that still there are some areas that need further development. In other words, still the space is available in some of the areas where

we have the ability to develop the tool for a better service than today itself.

Learning Management System is directly emerged from elearning. This has mainly focused on online learning delivery. This hints the idea that Internet is a main necessity for this tool. By way of conclusion, Sri Lanka has so many limitations in the service of providing internet facility throughout the country. Therefore, couldn't achieve that much of improvement in the field of higher education in government sector. Moreover, the lack of literacy or else the lack of basic Informational Technological knowledge in rural areas is also another hindrance in the path to higher education's success. As a solution for this Ministry of Education has conducting so many projects to enhance the level of ICT knowledge of the students during their school time by developing ICT labs with necessary tools to access the evolving technology. Conducting training programs, workshops and awareness programs will be so much valuable in the process of enhancing the knowledge of ICT in each and every student in the country. Sometimes without the usage, students may be reluctant to use digital equipment like PC's, laptops and tablets etc. This may happen without the necessary required training for the use of these digital equipment. As a result, proper guidance must be needed from the early childhood in order to move along with rapidly changing technological changes.

And another fact to ponder is that many higher educational institutions have failed to the high cost of technology, poor decisions, competition and the absence of a proper business strategy. This means that educational institutions need to be developed up to a maximum level in order to harvest the reap from other factors maximumly.

In the above this paper discusses the fact that student may lack their knowledge of using these technologies and being a two

wayprocess thisissue mayalso affect the other party also. In other words, this means that lecturers are the ones who are responsible for delivering the knowledge for the students and if they failed to go along with the evolving technology; there will be a great loss in delivering their service. Sometime the lecturers may be experts in the particular area that they are specialized but if they don't know the basic such as uploading a necessary word file to the LMS etc.They will try to go backward automatically and thiswill be amajor obstacle for doing their jobproperly and this will affect their professional image also.

## References

- Adzharuddin, N. (2013). Learning Management System (LMS) among University Students: Does It Work? *International Journal of E-Education, e-Business, eManagement and e-Learning*, January 2013. <https://doi.org/10.7763/ijeeee.2013.v3.233>
- Alshalawi, A. S. (2013). How Do Learning Management Systems Enhance Higher Education? *International Interdisciplinary Journal of Education*, 2(10), 1004– 1007. <https://doi.org/10.12816/0002965>
- C, S. N., & Patil, R. (2012). A Study on the Impact of Learning Management Systems on Students of a University College in Sultanate of Oman. *International Journal of Computer Science Issues*, 9(2), 379–385.
- Chen, C. K., & Almunawar, M. N. (2019). Cloud Learning Management System in Higher Education. September 2015, 29–51. <https://doi.org/10.4018/978-1-5225-7473-6.ch002>
- Emelyanova, N., & Voronina, E. (2014). Introducing a learning management system at a Russian university: Students' and teachers' perceptions. *International Review of Research in Open and Distance Learning*, 15(1), 272– 289. <https://doi.org/10.19173/irrodl.v15i1.1701>
- Fathima Rashida, M., Sabraz Nawaz, S., & Aboobucker Mohamed Sameem, M. (2018). Undergraduates' Use Behavior of Learning Management Systems: A Sri Lankan Perspective. *European Journal of Business and Management* [www.iiste.org](http://www.iiste.org) ISSN, 10(4), 38–47. [www.iiste.org](http://www.iiste.org)
- Grob, H. L., Bensberg, F., & Dewanto, B. L. (2004). Developing, deploying, using and evaluating an open source Learning Management System. *Journal of Computing and Information Technology*, 12(2), 127– 134. <https://doi.org/10.2498/cit.2004.02.08>
- Jafari, S. M., Salem, S. F., Moaddab, M. S., & Salem, S. O. (2016). Learning Management System (LMS) success: An investigation among the university students. 2015 IEEE Conference on E-Learning, eManagement and e-Services, IC3e 2015, August 2018, 64–69. <https://doi.org/10.1109/IC3e.2015.7403488>
- Joel, S. M. (2015). Learning Management System success: Increasing Learning Management System usage in higher education in sub-Saharan Africa Joel S .Mtebe. *International Journal of Education and Development Using Information and Communication Technology*, 11(2), 51– 64.
- Kommerell, G., & Klein, U. (1986). Adaptive changes of the otolith-ocular reflex after injury to the trochlea. *Neuro- Ophthalmology*, 6(2), 101– 107. <https://doi.org/10.3109/01658108608997334>
- Little-Wiles, J. M., Hundley, S., Worley, W. L., & Bauer, E. J. (2012). Faculty perceptions and use of a learning management system at an urban, research institution. *ASEE Annual Conference and Exposition, Conference Proceedings*.
- Machado, M., & Tao, E. (2007). Blackboard vs. Moodle: Comparing user experience of learning management systems. *Proceedings - Frontiers in Education Conference, FIE, December 2006*, 7–12. <https://doi.org/10.1109/FIE.2007.4417910>
- Murshitha, S. M., & Wickramarachchi, A. P. R. (2016). A Study of Students' Perspectives on the Adoption of LMS at University of Kelaniya. *Journal of Management*, 9(1), 16. <https://doi.org/10.4038/jm.v9i1.7562>
- Patel, Patel, C., Gadhavi, M., & Patel, A. (2013). A survey paper on e-learning based learning management Systems (LMS). [Ijser.Org](http://www.ijser.org) Patel,C., Gadhavi, M.,&Patel, A. (2013). A Survey Paper on eLearning Based Learning Management Systems (LMS). [Ijser.Org](http://www.ijser.org), 171–177. <http://www.ijser.org/researchpaper/A-survey->

paper-one- learning-based-learning-  
management-SystemsLMS.pdfC, Gadhavi, M., &  
Patel, A. (2013). A survey paper on e- learning  
based learning management Systems (LMS).  
Ijser.OrgPatel, C., Gadhavi, M., & Patel, A. (2013).  
A Survey Paper on e-Learning Based Learning  
Management Systems (LMS). Ijser.Org, 4(6), 171-  
177. Retrieved from  
[Http://Www.Ijser.Org/Researchpaper/A-  
Survey-Paperon- e-Learning-Based-Learning-  
Management-S, 4\(6\), 171- 177.  
http://www.ijser.org/researchpaper/A-  
surveypaper- on-e-learning-based-learning-  
managementSystems- LMS.pdf](http://Www.Ijser.Org/Researchpaper/A-Survey-Paperon-e-Learning-Based-Learning-Management-S, 4(6), 171- 177. http://www.ijser.org/researchpaper/A-surveypaper-on-e-learning-based-learning-managementSystems- LMS.pdf)

Sabharwal, R., Hossain, M. R., Chugh, R., & Wells,  
M. (2019). Learning Management Systems in the  
Workplace: A Literature Review. Proceedings of  
2018 IEEE International Conference on Teaching,  
Assessment, and Learning for Engineering, TALE  
2018Sabharwal, R., Hossain, M. R., Chugh, R., &  
Wells, M. (2019). Learning Management Systems  
in the Workplace: A Literature Review.  
Proceedings, January 2019, 387-393.  
<https://doi.org/10.1109/TALE.2018.8615158>

Sayfour, N. (2016). Evaluation of the learning  
management system using students' perceptions.  
Medical Journal of the Islamic Republic of Iran,  
30(1), 1-10.

Simkova, M., & Stepanek, J. (2013). Effective Use  
of Virtual Learning Environment and LMS.  
Procedia - Social and Behavioral Sciences, 83,  
497-500.  
<https://doi.org/10.1016/j.sbspro.2013.06.096>

Soykan, F., & Şimşek, B. (2017). Examining studies  
on learning management systems in SSCI  
database: A content analysis study. Procedia  
Computer Science, 120, 871-876.  
<https://doi.org/10.1016/j.procs.2017.11.320>

Turnbull, D., Chugh, R., & Luck, J. (2020).  
Encyclopedia of Education and Information  
Technologies. Encyclopedia of Education and  
Information Technologies, August, 0-  
7.<https://doi.org/10.1007/978-3-319-60013-0>

### Author Biographies

JMHK Jayalath is a 3rd year undergraduate  
student of the Information Technology  
department at General Sir John Kotelawala  
Defence University. She was actively

involved in creating the survey based on the  
topic and focused on the future enhancement  
and literature review in this paper. She also  
covered the area of completing the abstract  
and introduction.

WAN Malshani is a 3rd year undergraduate  
student of Information Systems at General  
Sir John Kotelawala Defence University. She  
has covered the area of Result and discussion  
and future enhancement in this paper. She  
also involved to complete literature review  
and introduction of this research paper.

PBD Ariyaratna is a 3rd year undergraduate  
student of Information Systems at General  
Sir John Kotelawala Defence University. She  
has covered the area of Methodology and  
conclusion in this paper. She also involved to  
complete introduction and abstract of this  
research paper.

NGC Ranahansani is a 3rd year  
undergraduate student of Information  
Systems at General Sir John Kotelawala  
Defence University. She has covered the area  
of introduction and abstract in this paper.  
She also involved to complete future  
enhancement and methodology of this  
research paper.

Mr. WAAM Wanniarachchi is a Lecture  
(Probationary) in the Department of  
Information Technology in General Sir John  
Kotelawala Defence University. He is  
interested in the field of research in Machine  
learning and Educatio

## Adaptive, Interactive and Distributed E-Learning portal with Resume and Asynchronous Learning Features for Colombo Stock Exchange

VSS Nanayakkara#and WAAM Wanniarachchi

*Department of Information Technology, General Sir John Kotelawala Defence University*

# 35-it-0026@kdu.ac.lk

**Abstract:** Development of Information Communication Technology have paved the way to evolution of educational industry with concept of digitization. With the radical development of smart, IOT devices and communication technologies have paved the way for rapid development of education system. E-Learning is a methodology which uses advanced technologies by exploiting digital network dynamics and the giant digital flow of information across the internet. E-Learning process explain the ability of an individuals to view online materials over the internet with the revolution of digitalization. Thanks to digitization the ubiquitous of education has been improved. In this situation Colombo Stock Exchange (CSE) is having a desperate requirement of increasing the number of investors in share market and to provide knowledge on share market transactions. To facilitate the said requirement with the collaboration with CSE an E-learning portal is developed for the potential investors to learn about the CSE and share market transactions. The portal is developed using various E-learning techniques to provide a potential learner/investor to understand subject matters with minimum cognitive effort. E-learning portal comprises of Wizard oriented chapter courses, Video tutorials, online publications, E-books purchasing ability, notifying CSE announcements, Live market transactions viewing capabilities, feedbacks, and online webinar features. As the main framework ASP.NET(MVC) is used along with various supportive frameworks in order

to develop a highly responsive web app on both mobile as well as desktop platforms.

**Keywords:** Digitization, CSE, Electronic-Learning.

### Introduction

With the development of modern technology and revolution of digitalization entire global system got changed and keep on changing. Digitalization is an integration of digital technologies into day to day life and business world. Which means digitalization invaded every single industry in the world and no industry can be named without digitalization.

Education is one area where digitalization invaded heavily, and modern way of education is totally different to conventional teaching – learning methods.

(Our E-Learning approach, n.d.)E-Learning is a methodology where use of advanced technologies by exploiting digital network dynamics and the giant digital flow of information. E-Learning process explain ability of individuals to view online materials over the internet with the revolution of digitalization. E - Learning process totally changed the conventional onsite tutor student learning concept in a remarkable manner.

Thanks to digitalization, today students can enjoy all the luxuries at home and study via internet. This process is called E-learning and in the modern world E - learning is a key tool in the education industry. E - Learning has improved the self-learning skill and

provided the opportunity to an individual to engage in learning activities by using a various E-learning tools such as E-books, videos, power point presentations. Thanks to E-Learning learner's location, time, language and other specific determinants are no more barriers for learner's education. E-Learning process totally changed the conventional onsite tutor student learning concept in a remarkable manner.

Colombo Stock Exchange (CSE) is having a desperate requirement of increasing the number of investors in share market. To facilitate the same CSE need to develop an E-Learning hub for the potential investors to learn about the CSE and market transactions. Once the E-Learning hub is developed potential investors can enhance the knowledge about the share market and invest in the share market.

The proposed E-learning hub(Web Design: 11 Characteristics of a User-Friendly Website ( Social Media Today,n.d.) was suggested by the Colombo Stock Exchange (CSE) due to the following reasons-

- To facilitate the general public and stakeholders to learn about the stock market and related activities via E-learning portal as they wish irrespective of time, location barriers.
- Cost effective approach to learn about the stock market and related activities.
- Real-time feedback through the chat bot assistance("Chatbot," 2018).
- Use of various interactive materials such as books, videos, power point presentations.
- Instant delivery of market information

Currently CSE do not have any automated or feasible methodology to attract the potential investors by improving the knowledge about the share market. With the development of this E-learning portal potential investors can learn about the stock market in an in-depth manner and that will facilitate the potential

investors to learn the stock market and actively engage in the share market transactions. Once the E-learning portal is developed, similar platform can be utilized for other educational organizations for similar purposes with the necessary changes.

One of the major problem Colombo Stock Exchange have identified with the latest research findings are majority of market transactions are done by the corporate clientele, top rich niche clientele who are actively engaging in the business world and foreign investors. CSE further observed that Colombo, Suburbs and key towns ( Kandy, Galle, Mathara, Anuradhapura, Negambo, Jaffna) upper and lower middle classes have a great tendency to invest in the stock market but rural and village level cash rich people have a very low tendency in investing in the stock market. In present context young generation is having an eager to invest with stock market. However still an un-urbanize, remotely located people are having limitations to get to know about the stock market and related activities.

As an assumption CSE believe that the lack of information about the stock market and initial mechanism to engage with the market activities are the key drawbacks to actively join and engage in share market. With the intention of addressing the said issue CSE is organizing regional workshops and seminars. Further CSE have appointed the province level coordinators around the country to support the potential investors. However, the CSE regional workshops / seminars and by appointing regional level coordinators anticipated results are not visible. As a result of this, CSE is having a requirement of developing a special online hub for the potential investors to learn about the CSE. Once the hub is developed potential investors can learn about CSE functionalities, fundamentals of the share market, market behaviour, 291 listed companies and current position of those companies, market

performance, activities of the listed companies, transactions, updates of the on-coming CSE events and workshops, accessibility to read E-publications and most importantly online chat assistance.

The Aim and Objective of the proposed portal are as follow

#### A. Aim

With the introduction of E-learning hub there will be an improvement of stock market investors and on that context market transactions would significantly improve. This will lead to improve the country's GDP (Gross Domestic Production) in mid and long term.

#### B. Objective

Main objective is to develop an interactive and userfriendly E-learning hub to improve the knowledge of the potential investors and by doing that they can actively engage with the day today market transactions.

### Litreture Review

#### A. London Stock Exchange educational portal Academy

(Learning innovation | London Stock Exchange Group, n.d.) Since there is a growing interest internationally on financial market a necessity for financial education was risen. On 18 November 2008, the European Union (EU) Parliament commented on personal finance education and issued a session document entitled on "protecting the consumer" by enhancing consumer education and awareness on credit and finance. Through a monthly issuing of academic articles, Academy will provide a summary of how monetary markets work, to ultimately boost one's own personal investment and trading strategy( Analysis of Web Sites for e-Learning in the Field of Foreign Exchange Trading, n.d.). London Stock Exchange educational portal, Academy is unique type of a portal that is build combining the traditional as well as

technological approaches. Using the portal Academy combine instructor followed learning with interactive self-learning course materials. Courses provided in the portal are flexible giving the opportunity to the user to learn the way which is unique.

The learning portal is made up of two main foundation factors-

- Focus on collaboration- collaborative learning is followed using the virtual campus.
- Personalized career paths- Academy supports customized learning to students enabling to focus on the areas that need to most attention to fulfil future achievements(Training with Academy,n.d.).

London Stock Exchange educational portal is subdivided into many areas,

#### 1) Online courses:

The main range of courses provided by the portal are as follows

##### a) Self-learning courses:

On these type of (Online courses,n.d.): courses Academy provide highly effective E-learning resources and materials such as E-books, videos, and demonstrations to support a user to engage on self-studying.

##### b) Collaborative courses("Public courses," n.d.):

Using one's own E-learning platform, online space classes are conducted by specialist instructors which facilitates participants to collaborate with each other as small groups.

##### c) Blended Courses:

Designed to fulfil individual academic requirements of a user.

#### 2) LSEG Academy online learning:

LSEG Academy online learning portal organizes on-line classes, where participants on remote locations could interact with each other as small teams. Collaborative learning methodology is practiced under the supervision of trained academics and tutors.



The cooperative learning methodology promotes sharing of information, team working, online group works through 'peer-to-peer' discussions, chats, and virtual classrooms.

### 3) Virtual campus:

Virtual campus is an E-learning platform that is solely owned only by LSEG Academy. Virtual campus mainly targets to improve the cooperative learning methodology. The specialty of courses provided by LSEG Academy is that it is a mix of face-to-face teaching and on-line learning. All most all on-line courses could be accessed from anywhere. The price of an online training program is £100 plus VAT. As a Motivational act taken by LSEG, provides the opportunity to visit the London Stock Exchange in Milan. Each group is guided by an expert trainer who will lead and provide an introduction on how the market works on day to day.

On London Stock Exchange (LSE) education portal some key features identified are the availability of free courses as well as paid courses. Team observed that LSE learning hub was developed to cater to different knowledge level of users. The user can select the preferred course type as per the user existing knowledge level. The main drawback of the said portal is the user has no ability to check his progression while following the courses. The layout was well delivered where any person could initiate from the beginning to build up the knowledge on stock market basics and transaction activities.

### B. National Stock Exchange of India (NSE)

(National Stock Exchange of India Ltd., n.d.) A set of brokers created the Native Share and Stockbrokers Association, which later have become the Bombay Stock Exchange (BSE) in 1875. The Bombay Stock Exchange Limited is the oldest stock alternate in Asia and was the first inventory alternate to be identified by means of the Indian authorities, in 1956.

Today, the BSE is professionally managed underneath the general direction of the board of directors, which formulates larger policy issues and exercises events overall control. The board accommodates eminent professionals, representatives of buying and selling individuals and managing director of the BSE. In addition to the BSE, there are different principal exchanged—the National Stock Exchange (NSE) and the Over the Counter Exchange of India Limited (OTCEI)—which function at a countrywide degree

NSE targets on enhancing the knowledge of the investors to obtain strategic decisions related to financial market and transactions. In order to achieve this NSE initiated several educational initiatives such as certification programs, training, financial literacy at school level, short term courses at college level. As an effective approach to deliver knowledge on share market activities, education portal called "NSE Academy" and Finvarsity portal was introduced by National Stock Exchange of India [NSE] to provide a diversified financial education to develop new generation investors.

(NSE - National Stock Exchange of India Ltd.,n.d.)The prime motto of NSE Academy is "To introduce more firsttime investors to the Indian markets and attract them to our exchange, our outreach, advertising and expansion initiatives seek to transform India's strong culture of saving into an equity culture".

The NSE Academy plans to provide necessary education to school level which promotes financial literacy as a necessary life skill. Further "NSE Academy" strategically developed interactive courses on personal finance and certification programs in schools. Further "NSE Academy" targeting other non-finance professionals introducing the Indian capital markets and value of investing help to develop new market professionals.

### C. Trends in E-Learning Techniques(Gaur, 2015)

Undoubtedly E-learning is changing the educational sector rapidly. The technology of information and communication has opened a new heaven for the experiments on teaching learning methods to make education interesting, flexible and extensive.

In a broad term E-learning includes several types of teaching-learning methods based on information and communication technology. Based on the participation of E-learning content can be classified into two types-

- Complete the online learning.
- Combined learning.

#### a) Complete online learning:

This type of learning depends entirely on E-learning tools. Delivery of course materials, discussions, assignment, evaluation, the exam and other evaluations are carried out only on the electronic learning platform. Complete the online learning provides maximum flexibility to students in relation to location and time of learning.

#### b) Combined learning:

In this segment, E-learning tools are used to increase the effectiveness of conventional face-to-face methods as in the additional tools. Sometimes, these tools are used to reduce the time of face-to-face contact. Some part of the learning activities is done in the classroom and the rest of the part in the E-learning platform.

#### Advantages of E-learning:

##### 1) Global connectivity

E-learning provides fast and comprehensive access to learning resources. There is no meaning to the limit of the campus of the institutions. In E-learning people can connect around the world. This process provide ability to access the several countries located in different part of world. This process

provide ability access the resources and learning partners and allows us to use several electronic repositories. This process facilitates opportunities to create several groups of students and teachers around the world with common interests. E-learning breaks all the limits and create an unlimited space to share the knowledge of students and teachers.

##### 2) Quick access

Quick access to information is an important characteristic of E-learning. Ability to access the global information only from one mouse click E.g.-Ability to access the electronic books and electronic journals in a few seconds.

##### 3) Convergence of different media

Electronic learning platforms provide unique feature of having many types of media in one place, such as text, graphical illustrations, audio and video which facilitate to increase the quality and cognitive ability of the study material. Convergence of different mediums offers an ideal opportunity to develop easy to understand, excellent learning materials. Further provide the ability to break the monotony of the learning process and create interesting and easy-to-understand course materials.

##### 4) Flexibility

E-learning offers options for student's time and place of learning. In the conventional classroom learning method, the time and place are must factors. Students are required to enter to a private classroom at a time under whatever the circumstances. Electronic learning allows students to learn according to his or her own convenience and own timetable. Students have an ability to study the required subject material of their course anytime and anywhere. The concepts of online and on demand exams completely revolutionized the traditional educational system of the entire world undoubtedly.

### 5) Rapid creation

E-learning offers all the supports to associate vibrant Elearning study materials. Materials with the combination of text, graphics, audio, video and Photographs could be used to facilitate the said purpose. Textbooks and printed study materials are physical and printed impressions in large quantities. If the changes are needed, to update them it takes months, E-learning study materials could be updated as and when its required. In today's contest information updates incredible fast and that updated information needs to be updated in the study materials quickly. Otherwise people are learning the outdated information in the study materials.

For example: A printed study material data may be old and obsolete. But the same document in the E-learning platform information could be updated. Hence E-learning is bridging the gap between speed and the rapidly changing knowledge and information.

### 6) Ability to serve many students at a low cost:

Providing education for all the people required is the biggest challenge for a developing country like India where you have far remote areas. This demographic challenge can be easily address by the E – learning and would overcome the problem of scarcity of limited resources. The research's conducted and studies carried out confirmed that India needs thousands of universities and colleges, but financially It is not practical to open universities and colleges in such a large number. But in E-learning has the ability to educate a lot of students at a relatively low cost irrespective of geographical barriers. E-learning is an only tool to provide quality education at a low cost if the required IT (Information Technology) infrastructure is available.

### Survey Done Prior To The Development

(Systems analysis,n.d.)In order to gather requirements from the clients two data gathering techniques are focused (requirements elicitation techniques) to identify the functional and non-functional requirements-

- Questionnaire
- Interview

Interviews are followed as the primary medium to obtain informative information from the client, since it is a formal approach of collecting data on software projects. By conducting an interview, data and information from a broad perspective could be captured from different type of stakeholders with in the CSE.

As a medium of collecting data from the public audience, questionnaires are used, since it is an easiest and fastest way of collecting data from a non-target sample of audience. Questionnaire are developed comprising of 17 questions covering a broad context including (accessibility, UIX (User Interface Experience), functionality, user friendliness and content management). Questionnaire was presented to sample of 120 respondents and obtained their responses. The questionnaire is mainly based on close ended questions. As the sample space people who are engaged in various professions are selected such as doctors, engineers, judges, businessmen.

Outcomes of the questionnaire are subjected to a statistical analysis, which will assist in determining various requirements including functional and non-functional and user requirements.

### Results

Based on the analysis of interviews conducted the following functional requirements and non-functional requirements were identified.

#### Functional Requirements:

- Users need to create an account in order to interact with the learning portal.
- Each user is logged in to the system using a unique ID and a password to his/her dashboard.
- User must be delivered with today's market summary in his dashboard.
- User has the preference to initiate with following the course, access the publication, and watch the video tutorials.
- User must be provided with a progression bar to show the progress on following the online course.
- User must be able ask queries and obtain answers as response using a chat bot.
- Update user data.
- Ability to create and update the course materials, publications, video, and other related online materials.
- Ability to add or remove users (user management).
- Ability to stream workshop and other seminars using a webinar.
- Obtain feedback from the registered users.

#### Non-functional requirements:

- Interface-The layout and UI which user interact from the logging page to the course modules(Wong, n.d.).
- Availability-The portal should be available (24x7).
- Security-Part of E-Learning database may be confidential and as the data is distributed on different servers on public cloud, data is out of the control from the customer as well as from the administrators. As a result, necessity of strong security measures is taken such as SSH and HTTPS.
- Usability: Interface of E-Learning portal should be user

- Effectiveness

#### Methodology

E-learning portal development is a challenging aspect. It mainly deals with combining human understandability or interaction and executing them using various technologies. Since the understandability, capability of a human differs from one another various cognitive learning techniques should be utilized.

Main learning features provided to a registered user are as follows

##### A. Designing based on visually aspect

After analysing the outcomes from the questionnaires 91.7% is intended to use the portal on the night time(Most of the users are employed so only leisure time available for them is at night).Since most users are intended to use the portal at night time the user interface is designed using light colour theme that also contribute to reduce the stress level of the user.

Navigations are designed based on the responses from the questionnaire such as 50.0% agreed on using of interactive links and consistent navigation mechanisms while 8.3% strongly disagreed to this factor and 8.3% provided neutral responses.

The portal dashboard from user's perspective is designed mainly based on icon driven menu rather than text driven menu. According to the responses 83.3% have agreed on Icon based while 16.7% have agreed on text based.

##### B. Designing based on multimedia aspect-Video tutorials

Based on the responses from questionnaires all most 100% agreed on using of multimedia content. The E-learning portal developed to CSE consist of video tutorials, by which a user who has difficulty on following the text-based wizard course can follow the video tutorials to obtain knowledge on CSE.

### C. Designing based on courseware aspect-Course

This one of the main use cases of the portal in which a Wizard oriented course following approach was developed. The main reason for using this approach is mainly based on the responses from the questionnaire. Accordingly, 41.7% strongly disagreed for reading paragraph with more than 20 lines, 25.0% Strongly agreed on reading paragraph's with more than 20 lines. As a respect to the said response Wizard oriented course following technique was developed.

Once a user logged into the main user dashboard a user can start following the course based on their preference Beginner, Intermediate and Advance. These are mainly categorised so that a user can start following the course based on their current knowledge level. Once a user starts with a preferred choice a progression level is indicated to show the status of course completion.

In order to maintain the resumability, the portal provides the ability to the user to follow the course from the point which he/she stopped earlier. This is one of the new features which has been introduced and embedded to the portal. Main advantage of this feature is, it provides the cross-device accessibility, as well as saves time and effort to the user on searching the previously stopped point.

### D. Publication

The potential learner is provided with E-bookcase, related publications, and research data by which a registered user could log into the portal and purchase the E-books using the cart and make the payments using an online gateway system. In order to provide real book reading experience to the user the turn page JavaScript is integrated to each and every E-book opened itself on the portal. CSE identified this as an interactivity factor and according to the responses from the

questionnaires 50.3% Strongly Agreed and 8.3% Strongly Disagreed on using this.

### E. Announcements

Traditionally CSE workshop and other market related announcements are made using newspaper articles. Based on the research's conducted by CSE they have concluded that most of the potential investors are not effectively communicated. As a feasible approach the announcements are notified to the registered user's once logged in to the portal.

### F. Feedback

Feedback will allow a registered user to communicate the improvements, issue, subject related questions, and various grievances to the CSE. On CSE perspective this will help to obtain feedback from the potential investors to make further improvements on the portal and what he/she feels about it.

### G. Market Summary

Market Summary is a live widget feature which will allow a registered user to study the live market transaction when logged during the stock market active hours.

### H. Online Workshop Stream

As mentioned before in order avoid the difficulties of potential investors in remote areas to participate in workshops, the portal is developed with online webinar feature. With this registered potential investor could log into the portal and participate to the live stream (the webinar could be accessed only from the portal).

## Technologies Utilized

As the main framework ASP.Net MVC (Model-ViewController) ("Is MVC different from a 3 layered architecture? - Quora," n.d.) is used that is followed by C# as the main scripting language, which is primarily used for managing the backend. ASP.Net is ideal to design web-based applications which consist

of user-interface and data handling applications with complicated backends. Controllers are mainly used within the portal to route and forward individual webpages based on the user’s request. Controllers are identified as the main backbone of the portal which route the actions of a request by handling the methods and parameters. Front end was developed using HTML (Hyper Text Mark-up Language), CSS (Cascading Style Sheets), JavaScript, Angular Components and Bootstrap frameworks (“Multitier architecture,” 2019; Naren, 2019).

Database is developed under the relational database schema architecture, where SQL (Structured Query Language) is used. As the database management system SQL server 2017(Community edition) is used. The database is developed under guidance of ACID properties. Such as Atomicity, Consistency, Isolation and Durability.

**Discussion And Future Work**

The portal is intended to be equipped with the chatbot facility which allow the user to ask queries and obtain response in real time. The chat bot is intended to be designed using Machine learning, where user might be able to carry out questioning over and over under the same topic without help of a chat assistance.

**Conclusion**

Technical and User acceptance testing is conducted by presenting 97% completed system to the higher officials of CSE IT department, Heads of Human Resource department and relevant representatives of Consumers affair’s department of CSE. Results are collected by feedbacks and suggestions from individual users through questionnaires which are concerned on future improvement and enhancements. The following are the results/responses from the feedbacks which is mainly intended to test the functional requirements of the portal (Figure 1)-

Sample client test case to the proposed E-learning Portal

User Based Testing Cases	Pass/Fail	Date	Percentage
1. Does the user sign up page is convenient	✓	02/10/2019	78%
2. Does the User interface design is convenient for learning and handling?	✓	02/10/2019	83%
3. Does the page responsive?	✓	02/10/2019	90%
4. Are all the functional requirements satisfied as expected?	✓	02/10/2019	97%
5. Are all the non-functional requirements satisfied as expected?	✓	02/10/2019	99%
6. Do you think “Consistent navigation” is convenient for you?	✓	02/10/2019	82%
7. Do the user dashboard convenient?	✓	02/10/2019	88%
8. Does the learning methodology design is convenient?	✓	02/10/2019	91%
9. Does the portal navigation convenient?	✓	02/10/2019	87%
10. Does the E-learning portal resource full?	✓	02/10/2019	72%
11. Does the course following wizard works as expected?	✓	02/10/2019	77%

Figure 1. User Acceptance Test Results analysis

At the conclusion of the development the main intention is to develop an interactive, more resourceful and fully functional E-learning portal, by which it would be beneficial for the potential investors to enhance the knowledge in the stock market and then invest in the stock market which ultimately leads to achieve the goals and objectives of the CSE. Consequently, this will lead to support a higher GDP in the country.

**Acknowledgment**

This development and the research behind it would not have been possible without the exceptional support from staff of Colombo Stock Exchange. Specially I would like to thank the CIO (Chief Information Officer) of CSE IT department for giving the opportunity, effort, and time to successfully accomplish the development and research.

I would like to thank Maj RMM Pradeep and Mr. WAAM Wanniarachchi for the guidance and comments that greatly improved the manuscript and the guidelines provided for developing the portal.

**References**

About SGX Academy – SGX Academy, n.d. URL <https://www.sgxacademy.com/about-sgx-academy/> (accessed 7.11.19).

Chatbot: What is Chatbot? Why are Chatbots Important? - [WWW Document], 2018. URL <https://www.expertsystem.com/chatbot/> (accessed 2.18.19).

Gaur, P., 2015. Research Trends in E-Learning. Media Communique NIU Journal of Media Studies, ISSN 2395-3780 1, 29–41.

Is MVC different from a 3 layered architecture? - Quora [WWW Document], n.d. URL <https://www.quora.com/IsMVC-different-from-a-3-layered-architecture> (accessed 8.18.19).

Learning innovation | London Stock Exchange Group [WWW Document], n.d. URL <https://www.lseg.com/markets-products-and-services/business-services/academy/training/learninginnovation> (accessed 7.8.19).

Multitier architecture, 2019. . Wikipedia.

Naren, 2019. Introduction to System Architecture Design [WWW Document]. Medium. URL <https://medium.com/backendarmy/introduction-to-systemarchitecture-design-fcd4f327b6c9> (accessed 8.18.19).

NSE - National Stock Exchange of India Ltd. [WWW Document], n.d. URL <https://www.nseindia.com/education/content/education.htm> (accessed 7.1.19a). NSE - National Stock Exchange of India Ltd. [WWW Document], n.d. URL [https://www.nseindia.com/education/content/module\\_nccmp.ht m](https://www.nseindia.com/education/content/module_nccmp.ht m) (accessed 7.1.19b).

Online courses [WWW Document], n.d. . London Stock Exchange Group. URL <https://www.lseg.com/marketsproducts-and-services/business-services/academy/coursecalendar-uk/activities/online-courses> (accessed 7.1.19).

Our E-Learning approach [WWW Document], n.d. . Elearning. URL <http://www.elearning-cegos.com/our-elearningapproach/approche-elearning/> (accessed 2.18.19).

(PDF) Analysis of Web Sites for e-Learning in the Field of Foreign Exchange Trading [WWW Document], n.d. URL [https://www.researchgate.net/publication/282599594\\_Analysis\\_of\\_Web\\_Sites\\_for\\_eLearning\\_in\\_the\\_Field\\_of\\_Foreign\\_Exchange\\_Trading](https://www.researchgate.net/publication/282599594_Analysis_of_Web_Sites_for_eLearning_in_the_Field_of_Foreign_Exchange_Trading) (accessed 7.8.19).

Public courses [WWW Document], n.d. . London Stock Exchange Group. URL <https://www.lseg.com/marketsproducts-and->

[services/businessservices/academy/training/public-courses](https://www.lseg.com/marketsproducts-and-services/businessservices/academy/training/public-courses) (accessed 7.1.19).

Systems analysis - Wikipedia [WWW Document], n.d. URL [https://en.wikipedia.org/wiki/Systems\\_analysis](https://en.wikipedia.org/wiki/Systems_analysis) (accessed 7.29.19).

Training with Academy [WWW Document], n.d. . London Stock Exchange Group. URL <https://www.lseg.com/marketsproducts-and-services/business-services/academy> (accessed 7.1.19).

Web Design: 11 Characteristics of a User-Friendly Website | Social Media Today [WWW Document], n.d. URL <https://www.socialmediatoday.com/content/web-design-11-characteristics-user-friendly-website> (accessed 2.18.19).

Wong, E., n.d. Shneiderman's Eight Golden Rules Will Help You Design Better Interfaces [WWW Document]. The Interaction Design Foundation. URL <https://www.interactiondesign.org/literature/article/shneiderman-s-eight-golden-rules-will-help-you-design-better-interfaces> (accessed 8.18.19).

## Author Biographies



Samudith Nanayakkara is a Third-year undergraduate student of General Sir John Kotelawala Defence University, Department of Information Technology, Faculty of

Computing. His research interests include in the field of Machine learning and deep learning, Full stack web development and UI designing. Currently he is volunteering to various volunteer driven groups such as IEEE Young Professionals of Sri Lanka and Google Cloud Sri Lanka as a university representative.



WAAM Wanniarachchi is a Lecture (Probationary) in the Department of Information Technology in General Sir John Kotelawala Defence

University. He is interested in the field of research in Machine learning and Education.



## E-Performance Management Process for Athletics in Sri Lanka

PKCD Pallewatte# and DU Vidanagama

*Department of information Technology, General Sir John Kotelawala Defence University*

# 34-it-029@kdu.ac.lk

**Abstract:** Automated systems indeed have become indispensable in our daily lives. More varieties are introduced into Automated systems second by second and existing applications are being enhanced and broadened. Due to the rapid growth it is the right time to Athletic management professionals to tap into the power of web context to provide correct information effectively, efficiently, keeping the Athletes loyalty and faith. Automated system will be contributing in changing the way of existing manual athletic system in Athletic association'. Athletes currently seek for non-complicated services which are faster simultaneously. Through this research paper, we focus on the potential implications of improved efficient Athlete registration procedure, Coach athlete communication, timing detection and storing procedure, Displaying performance evaluation procedure.

Finally, this research paper provides evaluates the performance of all athletes in Sri Lanka by addressing the topic of Sri Lanka Athletic performance and registration web-based system to improve the athletics in the country. Using this system, they can prepare for their future championships like the Olympics.

**Keywords:** Athletic performance, Athlete registration, database, web development, Timing detection, IOT Module

### Introduction

In this new technological era, the world's people have proposed software solutions as a major way of dealing with real people's

problems. Software solutions can be used to accelerate the efficiency, accuracy, cost effectiveness, mobility, reusability, and many more aspects of a manual process. Evolutionary concepts such as the Internet of Things and the progress of networking involve more people in a global village than ever before. Among other software technology programs, databases, web and multimedia software applications are increasingly used to develop solutions for different industries. There are many software engineering technologies, tools and platforms available today for developing software applications for enterprises. This research paper presents a project to develop a software solution for the Athletic Management in Sri Lanka.

### A. Problem in brief

In Sri Lanka their athletic management is getting manual system. In Sri Lanka athletes from different schools, universities, clubs at the National level compete annually for a different championship.

Here they must register with each championship. They register using registration forms that they get in the Sri Lanka Athletic Association. Where they must give their details by filling out that form and post it to the Athletic Association.

Athletes in Sri Lanka have done well. However, there is no official website and database for athletes. They are our heroes and their history need to be preserved for generations to come. It is necessary to keep a database of their past performance. The way to go is to come up with athlete performance

and Registration. They are trying to check School athletes to the National level. But Some School Level Athletes stop their sports life because of misunderstanding about their performance because they cannot check their past performance. In Sri Lanka, they cannot watch their past performance because all the performance details (Track and Field that means Timing for Track and Distance for Field) are stored in a file-based system.

In other countries, they have an electronic timing system, the official website for the sports so it is easy to check the performance evaluation of athletes in their country. But in Sri Lanka, they haven't the necessary way to store that data. Because of these issues, it is essential to develop a reliable website. To keep the athletic performances to a database and develop an automated registration system, where it is easy to keep and secure this data.

This paper gives knowledge about the automated registration system and storing all data of athletes in the database.

### **Literature Review**

Need to evaluate performance management in all sports. Currently, sports consultant-manager evaluations are not based on specific criteria, because coaches-managers are involved in performance sports. Do not confirm to counsellors. A performance management system is a performance - centre process that reflects how an organization approaches performance and includes sub-processes such as defining and implementing strategy, also training and performance management system. Several performance levels can be used here as a solution they think will help to develop a performance management system for Sports. From this perspective, the performance management level of sports consultancy managers affects the optimization of all specific activities.

Should be evaluated based on objective and unitary criteria. (Badau et al., 2010)

Here databases are used in sport administration. Some of these areas are provided below together with a discussion of the key elements of good database design. Databases are used to capture, storage, management, analysis, retrieval, interpretation and reporting data. And that data should be effective in performance analysis and decision making. Database is useful as multimedia repositories in sport information. Then databases are used for information access via creative interfaces that provide timely and efficient information that is tailored to each individual's unique requirements (Vincent, Stergiou and Katz, 2009)

In the past athletes would train with a coach under the supervision or direction of the sports federations. In the modern world the first timing system is Hand timing system. In this system everything is done manually. Time keepers get timing from using stopwatches then they write it in the paper and add it to the report book. But the world is combined with technology and they are using electronic systems to measure timing. European countries use this first electronic system; there are no databases that only generate text files now in Sri Lanka using that method. But now European countries use a high-performance system to measure the timing in track and measure the distance in the field. There is a database to store that performance and they have their own website to display that performance. Athletes can get their performance details by using that website. In the future they think to improve with some other techniques for athletics.(Sotiriadou and De Bosscher, 2018)

Athletic performance can be assessed by analysing specific variables that provide information about the physical condition of the athletes. Mainly strength and power related variables are the standard for the

athletic evaluation. The system automatically determines evaluation parameters and integrates them in ready-mode reports. Decreasing the time involved in the evaluation process. The Graphic representation of time evaluation of the variables being measured by the sensors is shown in real time on the screen. Evaluation session is defined by a protocol that can be specifically created by the coach for each athlete. Result of the evaluations is stored in an athlete's database so that the historical performance of the athletes can be easily assessed. In this article they used hardware side for sensor athletic performance there are four areas they sensor by, base station, multipower, jump platform, leg press using these four areas and monitoring athletic performance and timing. The purpose is to use a database to store that data and the coach can look at the history of athlete performance. Another thing is this system showing weaknesses and strengths of the athlete. (Silva, Martins and Palma, 2009)

There are different Athletes in the country like school athletes, university athletes, and national level athletes. There is registration for the athletes in the department. They must submit their details by profiling in the registration form. This wills the tedious work of the department unlike the traditional way of collecting the student athletes' profiles. Then they build up Athlete's Registration management and monitoring system. The result of this system developed is highly favourable to users. This system used to analyse the details about the athletes and can be used for competitions registrations also. There is an individual account for all the users. All can see the details about the athletes in Sri Lanka and their performance also displayed by the web site. Coaches also can register using this system and their details also there. Advantages of this system is we can stand up with new technologies. Another one is some schools where there are

no prizes but there are very talented athletes. They can search for a good coach by using this system and they can contact them. This is a very useful system to develop the sports in the country.(Montellano, 2017)

Most of the countries use the radio frequency identification device (RFID) for detecting athlete's performance in the championships. This device includes a silent gun, photo-finish camera and pressure sensitive start blocks to detect false starts. And another thing is at the race finish it detects the athlete 's upper part. All the detected details are generated by text document. Most of the countries detected these performances and displays by using web sites. And all the details are stored in the database. They can use these details by any time, because those details are stored in the database. This system is used to detect who is the winner of the race. Then it detects his/her timing and checks if it is recorded or not. If this is a good system, all the championship records are generated. Here this system uses many sensors that are photo sensors and the radio frequently detect sensors. This system can check lap timing also that's good for training sessions for the athletes because they can check their timing improvement .(Woellik, Mueller and Herriger, 2014)

### **Methodology**

A combination of qualitative and quantitative methodologies was used, considering the nature of the project to provide adequate process subjects to provide the functionality needed for software success. The quality part generates the theory, which is then verified by a quantitative part of the research. The main advantage of combining these two systems is the ability to develop a comprehensive software solution Cover all the conditions of the Athletic management process.

In the requirement analysis phase data gathering techniques such as questionnaires,

interviews and surveys were used to gather qualitative and quantitative data required for create the requirement specification for the E-performance athletic management system.

Architectural design defines the relationship between the overall structure and the components of the solution before it goes to the detailed design or the lower level design, which includes the design of specific component details. The architectural design is provided in a layer-by-layer architecture, and the overall design spans three layers: client layer, application layer, and data layer. The overall system architecture for the proposed system is as follows.

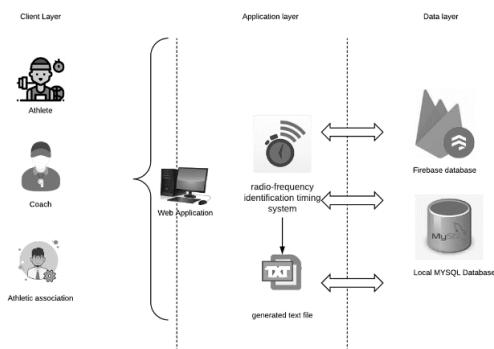

Figure 5: System Architecture

Identifying athletes' real performance for establishing their performance evaluation and giving timing results for resource management and store the timing in the sport management is the main three parts of this research. Functional requirements of this project monitor electronic timings, timing stored in the database, preview data about coaches using AI chat bot, displaying upcoming championship details and all the results of the championship generate year reports and performance evaluation reports.

#### A. IOT Module

In data gathering we identify parameters that can be able to easily measure in order to detect Athlete timings. Those main parameters are:

1. distance of the race track

2. Speed timing of the athlete

3. detect 8 lanes

4. assign athlete numbers to each lane.

Therefore, these parameters should be collected in analysing proper manner to detect Athlete timing accurately. To achieve this there should be collected in analysing proper ways to monitor the parameters and collect values for athletic performance evaluation. Use of IOT technology will be a great solution for this requirement. Main reason which greatly influences this monitoring purpose is the capability of sensing the speed and distance of IOT technology. IOT is proven to be fundamentally capable enough to provide more significant scalable, portable and energy efficient solutions to various problems in the athletic management system. Specially for the timing detection purposes. Therefore, for the solution, here sensors are used, 1.4bit line hunting sensor module-for detect starting point values and finish line values. This sensor is able to detect each lane's single values separately. And the sensor and the object by measuring how much time passed between start and finish the lane. We use other IOT parts. Hats are, 1. Mega Arduino 2. Ethernet shield 3. 128\*64 Dots Graphic Blue Backlight LCD Display ,5.4\*4 16 key membrane switch keypad module. Then the values which are gathered from the sensors will be passed to the main system using an Ethernet shield and then the main system will store them and do the analysing and displaying part. All these details will be stored in the databases for other purposes.

#### B. AI Module

A chatbot gives them an easy way to get the right coach information fast. Entrants may still have questions that a website itself does not answer or does not answer quickly enough. Entrants often find it easier to ask than to search a website. In that case, the

chatbot acts as a super navigation assistant to the current information.

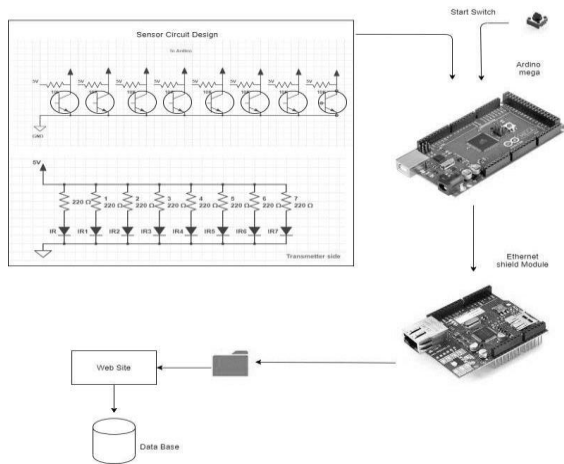

Figure 6: IOT Module Architecture

### C. Main Web Module

All the isolated details and information of each sub module will come to this main module and store them for the integrated process. This module is responsible for every process. That is, Gather the sensor details from the Arduino module and process them. This main web module admin is Sri Lanka Athletic Association. In here admin adds the competition registration link to the web site. Then they can get all the registration details about who participates in the competition. Then they can easily create competitor's chest numbers using this system. And also, they can publish competition results using this system. Another section is the users are competitors and coaches. Users can register the competition by using that registration link. Users have their own account. School registration is more difficult than other registrations because they should upload the confirmation letter and they should register in their age sequence like (Under 20, Under 18, Under 16 etc.). National Athletes can register individually; all the coaches can register with their details individually then the system suggests to the competitors for good coaches by checking their performance. And anyone can check the results of the competitions. And also; they can check performance of the Athletes in Sri Lanka by

events. Example like who is the Sri Lankan Fastest man. They can check their performance year base. This system's main purpose is creating a database for the Athletics in Sri Lanka and performance improvements of the athletes. Athletes can know when their performance is a failure. This system gives a message to competitors how much their performance is lost at the Olympics.

Non-functional requirements are security, Availability, Reliability, Recoverability, Maintainability, serviceability. Security is very high because the competition registration fee is the main requirement of the competition and user details must be protected with this system. In this system you have available services any time that is a good effect of this system and its mean also serviceability.

### Technology

#### A. Google Firebase

Firebase Database is a real-time database that stores data in JSON format. It provides an API that allows developers to store and sync data. The admin login module connects with Firebase to authenticate users to the application. By default, only authenticated users have access to read/ write, but this can only be published via configuration. Each user has distinct privileges and access to each specified module after they are logged in.

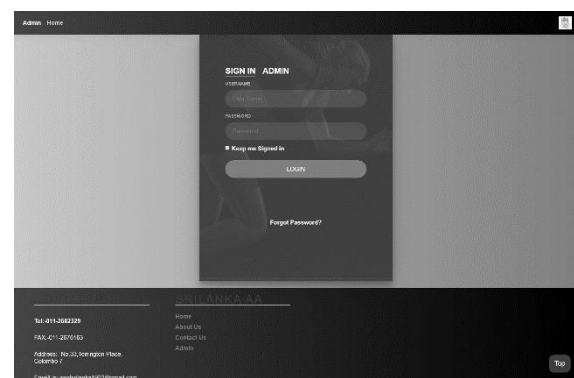

Figure 7: Login Interface

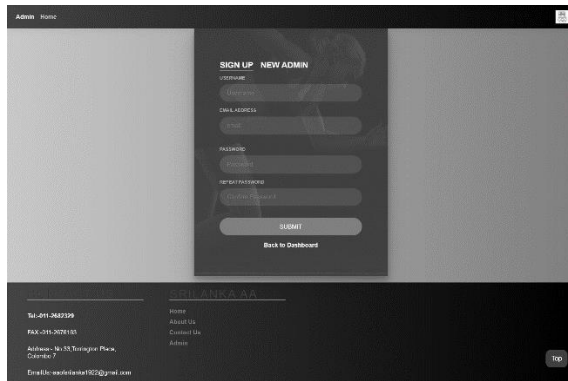

Figure 8:Registration Interface

### B. MYSQL Local Database

MySQL is the most popular language for adding, accessing and managing database content. It stands out for its quickness, proven reliability, ease of use and flexibility. Entire web application connected with MYSQL local database.

### C. IOT Technology

The Internet of Things, or IoT, is a set of interconnected computer devices, mechanical and digital machines, objects or individuals that provide identifiers and transmit data over a network that people do not need. Human or human-computer interactions. In the IOT module there is a timing detection device for each athlete in the one race. Using IR sensor beam for detect timing in each athlete who participate the event. Use Arduino tools for build timing detection device. And Finally get the text file for each event. And pass that data to web application.

### D. ASP.Net

ASP.NET is a client-side web application framework designed for web development to produce dynamic web pages. It is purpose is to improve the android development and help to build the highest quality optimized applications. Whole web application developed by using ASP.NET.

## Evaluation & Discussion

The main purpose of an evaluation is to ensure that the system meets the needs of

real users. This section describes in detail the planned evaluation process. Evaluation is a study of research procedures.

The systematic use of judging the quality or value of a service or intervention provides evidence that can be used to improve it. "Is the software developing in the right direction?" Such a question must be met. Or "Does the software meet user requirements?" Conducted through the software evaluation phase. System evaluation can be divided into summary evaluation and model evaluation. Formal evaluation improves the system while it is being evaluated. It helps to maintain quality standards. Summary evaluation is the evaluation of a completed project. It is used to assess the success of the final product. Assists in assessing the system's replicable operational needs and executes user requirements in the software development lifecycle.

First, we do a survey and get results of 95.8% athletes and 100% coaches have problems in the existing system.

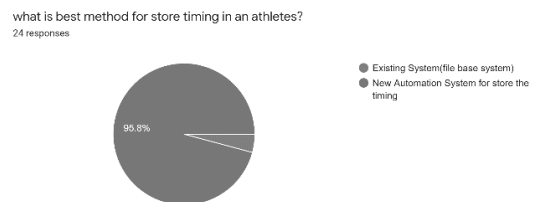

Figure 9: Athletes idea for the new system

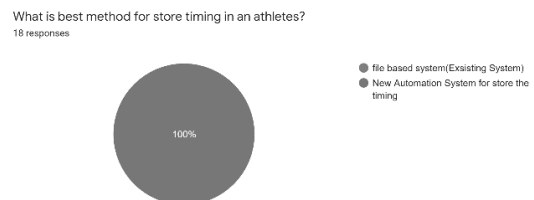

Figure 10: Coaches idea for the new system

As a solution we decide to build an E-Performance Management Process for athletics in Sri Lanka, making use of the recent

advances in technology, we create a new solution for the existing registration system. Introduce a new online registration system and, also give a solution with a database for athlete performance storing safely. Also using this system and rural athletes can improve their performance with good coaches. They also can achieve with other Urban athletes.

IoT provides us with seamless interconnection between heterogeneous devices. Analyse and integrate data on various IoT devices used for timing detection.

Once the e-performance athletic management system is developed, the entire system is tested by unit tests, integration tests and acceptance tests. Athletes of all stages are given to the athletes and their prototypes are improved and tested accordingly. This solution reduces traditional systems in Sri Lanka and gives a new step to Athletic evolution of Sri Lanka.

### Conclusion

Athletic management brings together all the knowledge related to the management of an athletic organization, whether local, national or international. The athletic management system is not only rewarding but it also helps the programmer to quickly organize the athletic events and lists in a short interval of time. I personally see this as a great way to find even more information about my topic. It will be able to check anything related to athletic at any time. Paperwork and manual work are reduced through this system. The system is user friendly and easy to use. I hope that the user would not only enjoy this system but also get satisfaction from finding how each and every feature of athletic management is implemented.

### References

Badau, D. et al. (2010) 'Performance management in sports for all', *International Journal of Education and Information Technologies*, 4(2).

Montellano, J. M. (2017) 'Development of Athlete's Registration Management and Monitoring System', 34(1), p. 15.

Silva, H., Martins, G. and Palma, S. (2009) 'AN AUTOMATED ATHLETE PERFORMANCE EVALUATION SYSTEM - From Theory to Practice', in. *SciTePress - Science and Technology Publications*, pp. 239-244. doi: 10.5220/0001548602390244.

Sotiriadou, P. and De Bosscher, V. (2018) 'Managing high-performance sport: introduction to past, present and future considerations', *European Sport Management Quarterly*, 18(1), pp. 1-7. doi: 10.1080/16184742.2017.1400225.

Vincent, J., Stergiou, P. and Katz, L. (2009) 'The Role of Databases in Sport Science: Current Practice and Future Potential', *International Journal of Computer Science in Sport*, 8, p. 17.

Woellik, H., Mueller, A. and Herriger, J. (2014) 'Permanent RFID Timing System in a Track and Field Athletic Stadium for Training and Analysing Purposes', *Procedia Engineering*, 72, pp. 202-207. doi: 10.1016/j.proeng.2014.06.034.

### Author Biographies



Chami pallewatte is an undergraduate at general sir john Kotelawala defence University, faculty of computing. Her research interest is in the fields of Database, GIS, IOT, AI, Machine Learning.



DU Vidanagama completed her bachelor's in University of Kelaniya, in B.Sc. (Special) (Hons) in Statistics and Computer Science with First Class and B.Sc. in Information Technology, University of Colombo School of Computing. she has completed her Masters in Management and Information Technology, Department of Industrial Management, University of Kelaniya, Her research interests are in the fields of E-Learning, Big Data, Data mining, opining mining, Machine Learning, Multi-agent Technologies, XML Database She has published, reviewed, and supervised, many researches nationally and internationally.

## Introducing E-Farmer Management System for Dedicated Economic Centres in Sri Lanka to Reengineer the Current Marketing Process

KPP Sandareka# and N Wedasinghe

*Faculty of Computing, General Sir John Kotelawala Defence University*

#piyumisandareka7@gmail.com

**Abstract:** Dedicated Economic centers are established all around the country. With the long-term objective of Improve and enhance the sustainability of the agriculture sector in Sri Lanka. such as Ensure obtaining reasonable prices for agriculture producers, Farmers for their crops by providing a targeted market for their valuable crops, create an opportunity to distribute area-specific agricultural products among people in all parts of the island. But still, there are some serious problems which are not come up with feasible solutions the major problem in the current system is the lack of coordination between economic centers, farmers, and buyers. So, the main objective of this research paper is to give a feasible solution for those identified problems and enhance the productivity of Sri Lankan agrobusiness. This proposed system will connect farmers, buyers, and economic centers into one platform and provides Information about current production, Price Indexes, and current market condition. This Farming information management system for agricultural dedication centers is developed as a web-based application. The system uses a centralized database system where all the clients (Farmers, agrarian officers, and other users from the economic center) can connect to the system.

**Key Words:** E- farmer Management System, Agro Economy, Dedicated Economic Centers

### Introduction

Sri Lanka had a strong agriculturally based economy. Most Sri Lankans who lived in countryside areas are depending on the

agricultural economy. Also, Sri Lanka had a rich tradition that comes with nation agriculture. when considering the Sri Lankan agricultural industry rice is the main production. paddy is cultivated during two periods of time in a year called Yala and Maha season. and also, tea is another primary form of agriculture in Sri Lanka and the main source of foreign exchange. mainly Tea cultivated in central highlands. other than rice and tea another most important crops are vegetables and fruits. about eighty different varieties of vegetables and fruits are cultivated in three types of agro-climate areas in Sri Lanka. Sri Lanka produces more than eight lack metric tons of vegetables and fruits annually. The agriculture sector of Sri Lanka contributes seven percent to the national GDP (Gross Domestic Product) "After the 1970 's this agricultural economy drastically faced a crisis due to the economic reforms implemented in the country from 1978" To overcome this situation government has done several projects. Dedicated agricultural centers are an example of such a project. In 1999 an initiative was taken to establish a large-scale market center that would change the marketing situation for farmers. According to the Ministry of rural development, the main objectives of Dedication economic centers are, Ensure obtaining reasonable prices for agriculture producers for their crops by providing a targeted market, Provide an opportunity for small scale producers to minimize their transport costs and wastage in transportation, Provide opportunities for wholesale traders to purchase fresh fruits



and vegetables, directly from producers, Encourage the business community by providing a competitive marketing environment for wholesale traders. Create an opportunity to distribute area-specific agricultural products among people in all parts of the island, provide facilities for consumers to purchase food items at cheaper prices. (Development and Unive, 2016)

When analyzing the above objectives still some shortcomings are not solved properly because of some critical issues that have been occurred in the current system. The major problem is lack of communication between farmers and Dedicated economic centers (DEC), Incapability of finding a wide market available nearby agro-ecological zone because of the ultimate interference of intermediate person to the marketing process, lengthiness, and the complexity of traditional market channel. so the ultimate aim of this system is empowering small scale farmers by provide a target market and limit the interference of intermediate persons to the process of crop selling by updating farmers, with the latest market conditions. The establishment of dedicated economic centers was started in 1998 as a means of implementing marketing development strategies to provide marketing facilities to manufacturers in rural areas.

### Literature Review

There are different types of existing systems and experiments to take an actual idea about the technologies that other researchers have adjusted to apply the appropriate technologies to this proposed system. this literature review will give an idea of how the previous researchers have come near to their research and how they have implemented their works.

A.The existing e-farmer Management Systems

•(Karunaratne and vidanagama, 2015) Presented paper under the topic of E-farmer

Management System for Agrarian Service Centers in Sri Lanka to provide a web system to advance the existing agrarian services in Sri Lanka. The solution is to be carried out with a powerful mixture of few technology and software's This software is consisting of the following main features SMS based application service to inform the farmers regarding hazardous things, upcoming news, and schedules and remind the important information through messages. While they can review the comments and ideas of other farmers and expertise in this regard. Sell their products through the online shopping cart. With these new features, this management system maximizes the output and improve the following process that happens between the agriculture officer and farmers. Problem diagnosing capability, Decision Making, Accountability, Discussion forums, SMS facility, Alerts and update information, Reporting facility This system maintains a centralized database system where all the clients can connect to the EFMS network. There three separate login interfaces in the system which Farmers can access to the system using their phone as well as the computer while Agrarian officers can log in to the system with their username and password. As well as Coordinators can log in to the system. But the system limited their authority to work with the system. Primarily the coordinators have to concern about the farmers and respond to update each new thing relevant to the farmers and their crops. (Karunaratna and Vidanagama, 2015)

•(O. Noel, N. Fernando, and G. Wikramanayake 2014) Presented paper under the topic of "Web-Based Agriculture Information System" according to authors it is very important to have an information system to assist different kinds of users such as planters, researchers, inventors, and exporters in Sri Lanka. That information system developed for considering the main

corps of Sri Lankan agriculture. This system is available on the internet for various types of users. the system includes details about corps and inter corps, their production, expert details, crop and intercrop diseases, land availability, soil stability, fertilizer, research institutes, and research. The four main research institutes of Sri Lanka such as Rubber, Tea, Coconut and Rice Research Institutes maintain various Currently, the Internet provides so much information about companies that produce main crops like tea, rubber, coconut, and rice but information about crops and inter-crops, their production, crop and inter-crop diseases, land availability, soil suitability, are still not available on the Internet. This web-based information system addresses these issues too. (Noel, Fernando and Wikramanayake, 2014)

•(G. Pramod, S. Bhagat, D. Bhusare, S. Botre, and S. Pate 2016 India) presented paper under the topic of “E-farming” According to authors Farming and agriculture is the prime occupation in India but unfortunately, people who involved in farming are suffering from poverty. The main reason behind this poverty is the lack of awareness about modern high technologies, Automated machines, Availability of facilities. And the worst issue in farming is after all hard work and sacrifices to their production farmers are unable to get a good market for their harvest as they cheated by the agent. According to researchers, This is the main reason behind the poverty of most farmers in India. So “E-Farming “will provide a good market platform for farmers to sell their products across the country. The site will guide the farmers in all the aspects, the current market rate of different products, the total sale and the earned profit for the sold products, access to the new farming techniques through eLearning, and a centralized approach to view different government’s agriculture schemes including the

compensation schemes for farming. Getting availed to the required information related to the markets and different products can be made possible through the SMS facility provided by the system. (Pramod et al., 2016)

•(Tomoko Kashima, Shimpei Matsumoto, and Tatsuo Matsu Tomi 2013 ) presented paper under the topic of “Effects of Sharing Farmers’ Information Using Content Management System” according to others “In recent years, the number of agricultural-product markets is over the number of convenience stores in Japan. However, many farmers are experiencing a lot of problems nowadays. Farmers are rapidly aging because the young people who get an agricultural job are decreasing in number. Consumers worry about the safety of the food which Farmers produce because of the problem of the quantity of the agricultural chemicals used for agricultural products And, there is also a growing concern that the Trans-Pacific Partnership (TPP) has a negative influence on domestic agriculture. These problems could be a big opportunity to try and change domestic agriculture in Japan by introducing IT. They have already developed a Menu Recommendation System which gathers data on what people like to eat, and with that data, it can make automatic recommendations for an individual (Silva and Ratnadiwakara, no date)This idea can also be applied in developing the Agricultural Information System for urban markets, for the benefit of farmers and the local agriculture in Japan. This system will provide information on what agricultural products are in demand by analyzing consumer consumption and market trends. With this information, the farmers can have a better idea of what crops to prioritize. This can also help stabilize the economic sustainability of farming by improving farm management. With the system at work, it will reduce oversupply and undersupply of certain agricultural products, and the stable supply-

demand relationship will prevent the underpricing of agricultural products and help in stabilizing market prices.”(Eds, Conference and Hutchison, 2013)

- According to leT Research and Development in Africa, 2010 they Sayed The Information and Communication Technology (ICT) revolution has brought about unprecedented new opportunities in agriculture and rural development in developing countries. The use of ICT in agriculture has made significant contributions to improvements in agricultural production, food security, and better access to input and product markets. It has also improved the performance of rural agribusinesses, income-earning opportunities. (‘leT Research and Development in Africa’, 2010)

- Agriculture often appears to be one of the most difficult industries when it comes to trading Agri products are concerned. (faculty of social sciences university of Kelaniya A study about problems that farmers face in trading Agri products to economic centers) With special reference of Dambulla Dedicated Economic Center), 2016)(‘FACULTY OF SOCIAL SCIENCE UNIVERSITY OF KELANIYA A study about problems that farmers face in trading Agri products to economic centers ) With special reference of Dambulla Dedicated Economic Center )’, 2016)

- Farm Management Information Systems (FMIS) are of precision and easy to use Fundamental for effective management of farm operations. Nevertheless, many farmers still today do not use FMISs for various reasons, such as lack of awareness and the difficulty of many available FMISs. Appropriate FMISs hardly exist especially for small to medium-sized farms and multifunctional farms(Husemann and Novkovic, 2014) This paper aims for the deduction from a general FMIS of a concrete FMIS. The concrete FMIS will concentrate on the needs of medium and multifunctional

farms. This means the farmer must be empowered to allocate the farm's scant resources. We, therefore, selected a German farm

- Technological importance has been a great support to decision-making in various fields, particularly in agriculture. Agriculture development has been under development for the past few years due to a lack of knowledge of agriculture and changes in the environment. The main objective of this paper is to reach out to farmers in e-Agriculture for their knowledge, usage, and perception. The study utilized the technique of statistical survey design to collect farmers' data for their e-commerce knowledge. The results obtained indicated that the degree of knowledge is less such that e-agriculture is required to help them. E-Agriculture is a platform to promote the commercialization of agricultural products(FAO, 1995)(Nayak, Shenoy and Rajesh, no date)

## B. Features of e-Farmer management System

Main Features of the E-farmer management system as follows

- Decision making
- Accountability
- SMS facility
- Alerts and update information
- Reporting facility
- Alert Generating Facility

## C.Overview of Existing system in Sri Lanka

Current Process of Agricultural Marketing shown in Figure 9.

Agriculture Industry can be defined as one of the most difficult industries when it comes to trading Agri products. The present study tries to find out the key problem that farmers face in trading Agri products to Dambulla economic center

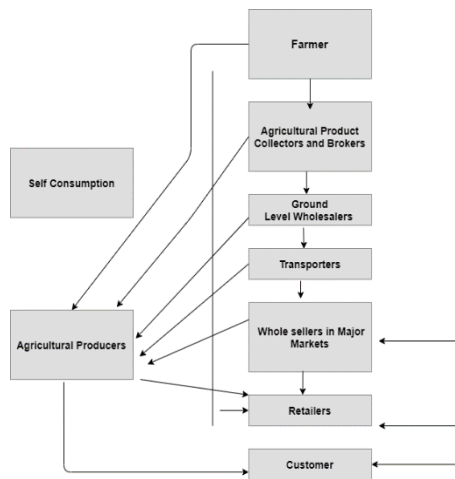

Figure 11. Process of agricultural marketing

According to saliya kumara (2011),100% of farmers are depending on the nearest Dedicated Economic centers to finding the market for their agro products. But only Dambulla and Thambuththgama Economic canters are facilitating the market requirement to this largest agro-ecological zone like Anuradhapura and Polonnaruwa zone. Therefor huge amount of vegetable production is failed to handle in Dambulla DEC's. As a result of that, a considerable amount of vegetables is wasted in the market floor and also those surpluses dumped into a sensitive environment like forests, reservoirs, and rivers nearby This can be which cause another set of environmental problems the middle man or intermediate person intervention is the most negative part of this process as they always depending on profit in return. Because of this interference and unnecessary chain of Intermediate person at several stages of the business caused to unnecessary price increases in the consumer markets

- Lack of communication between Dedicatoin Economic center and farmers
- The incapability of handling a large number of crops
- Farmers Incapability of dealing with the technology
- The incapability of producing Market

Farmer unawareness of their market conditions

### Methodology

Quantitative and qualitative methods are used to correctly identify the information, process, and communication requirements of the users of an EFMS Main spotlight of collecting data are finding data about Dedicated Economic centers and mainly knowledge is acquired using both structured and unstructured interviews with domain experts and from relevant documents by using documents analysis method to find the solution of the problem. All the Details and requirements are given from the head of the department and the staff members of Hector Kobbekaduwa Agrarian and the research center to get a broad idea about the Proposed system. as well as all the other important data were gathered by interviewing local farmers and buyers from the Dambulla area. Apart from that as primary data sources the developer uses books, surfing the internet, Research works, and case studies of the existing systems. A blending of these methods is used to accomplish the gathering of quantitative and qualitative fact This research uses the agile Dynamic System Development Method (DSDM) which is one of the important methodologies which come after the waterfall model. The agile method is based on giving main concern to user participation, from the very beginning of the development cycle. The objective is to keep the user involved at every stage. And most importantly It concerns customer Satisfaction. The Technology stacks which is used in the proposed system is P PHP, HTML, jQuery, AJAX, Bootstrap framework, Google map API, SMS gateway

#### A. Requirement analysis

This system has three main login interfaces. Administrator, Buyer, and farmers can access to the system using Those three different logins moreover every user have a unique

username and password which is given from the system when they registering to the system There are Main functional requirements of the system

Admin should able to,

- Gathering price Indexes
- Registering As the admin of the system
- Add farmers and buyers to the system with their relevant crop types
- Add Representative
- View Representative
- Remove Representative
- Add crop types and crop ID and quantity
- View crops types and crop ID
- Remove crop
- Sending price Indexes to farmers
- Sending Farmers prices to buyers
- Sending Buyers preferences to selected farmers

End-Users Should Able to

- Send own prices to the system
- Send Availability of crops
- Ask for price Indexes of crops
- Send preferences to the system

Apart from that as a usability requirement, the system's end-user should have little knowledge of how to use normal cell phones.

### B. conceptual model

E farmer management system uses a centralized database as shown in figure 2 Hector Kobbekaduwa Institute is deciding the prices of the vegetables, fruits, and rice along with the government. Those price indexes are sent to dedicated economic centers. From this new web-based system those price indexes will cent to the registered

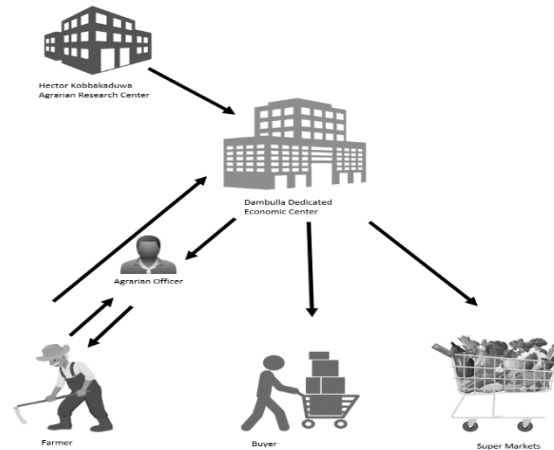

Figure 12. Work Process of Proposed System

farmers according to their relevant crop by simple SMS alert. every morning then farmers can decide their prices and send them back to the economic center. Then only buyers can know about price indexes. with this new system, the developer has reduced the lengthiness and interference of Intermediate persons to the marketing process by connecting Farmer, Byer, and economic center into one platform.

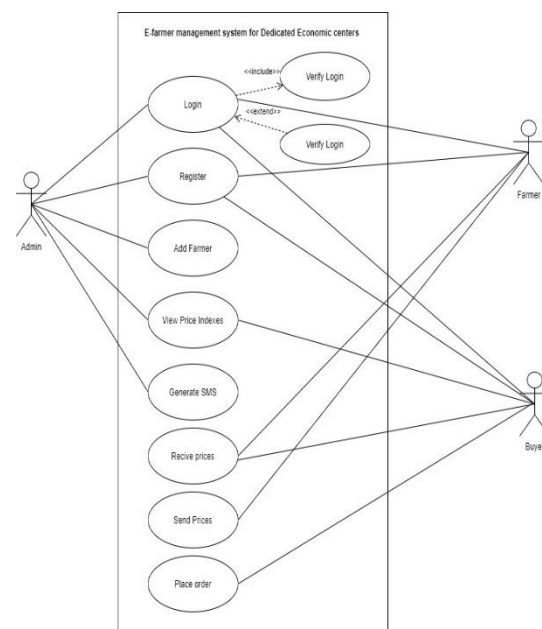

Figure 13. Use Case Diagram

### C. Implementation

The E-farmer Management System mainly consists of three main modules

### Login Module

Users of the system should be accessed through the login function. Users already should have username passwords to login to the system.

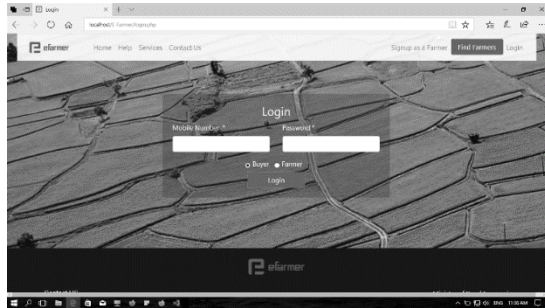

Figure 14. User Login

### Administration Module

Every primary user must register through the system by creating a user account. The administrator function is the one of most important features of EFMS. The administrator will add end-users to the system. The administrator has the full authority to change the details and delete the information and add or remove users. Also, the administrator can add price indexes, crop types, the quantity of the relevant crops and remove, update them apart from that administrator can send prices to the farmers and buyers which is the one of main functional requirements of the system. The administrator can add, Remove, update representative to the system.

### SMS Module

The system will send the SMS notification to the farmer's mobile phone the specialty of this system is this alert generating service is support for basic cell phones in all three languages. The system will send daily updates of price indexes of vegetables to the registered farmers. and farmers can send their prices to the system too. then the system will send those prices to buyers. Byers can see all those prices by simply login to the system. the system will show the price of relevant crops with the farmer's details.

byer can order their preferred vegetables from here with this simple step, it reduces the lengthiness of market channels and reduces unnecessary participation of intermediate person to the marketing process, and give full power to farmers to decide the prices of their valuable crops.

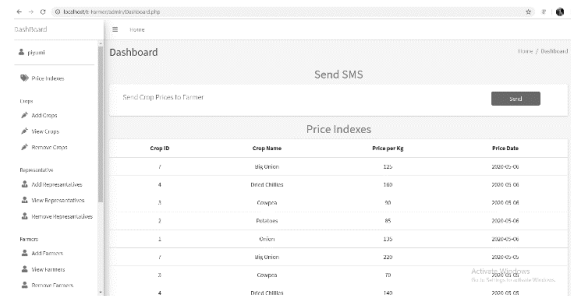

Figure 15. Admin Dashboard

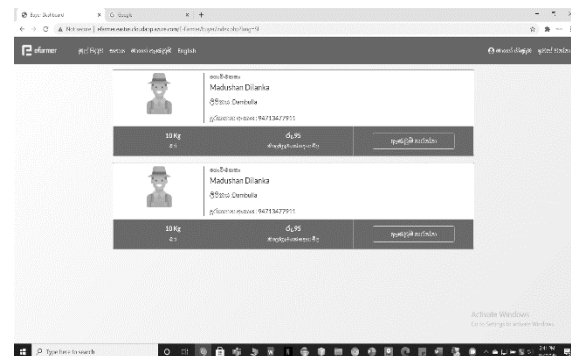

Figure 16. Farmers Prices

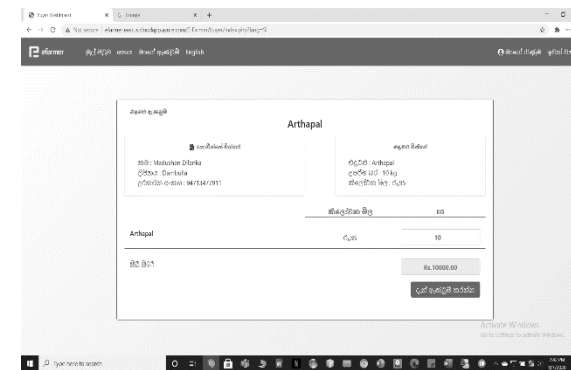

Figure 17. Byers Order Form

### Testing and Evaluation

The testing phase enables the established e-farmer management system for dedicated economic centers in Sri Lanka to be methods for data analysis to ensure that the requirements everything was developed to satisfy. At the production of certain modules, the components of the system have been

tested as units and integrated systems. And also the accuracy of the system was tested by participating 50 farmers in the Dambulla area. during the evaluation test sample price indexes send to farmers' cell phones and they are instructed to send reply their prices the same as the message template which sends with price index list.

According to the following pie chart, 38 farmers send correct messages while 12 farmers send incorrect messages. the overall accuracy of the system is 76%.

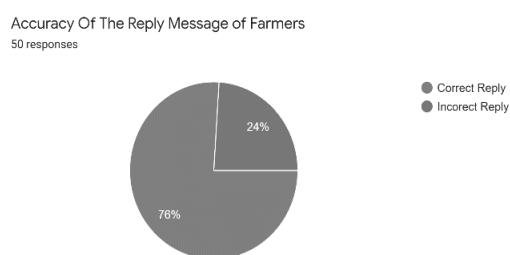

Figure 18. User Accuracy Chart

And the feedback result shows Satisfaction of the farmers about the E- Farmer management System

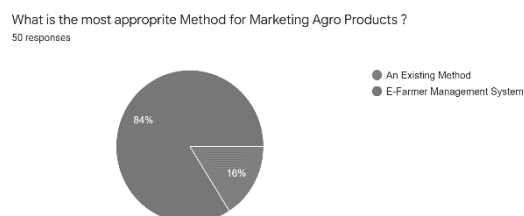

Figure 19. Accuracy pie chart

### Conclusion and Discussion

Sri Lanka is an agriculturally based country where adds 0.1% to national GDP. But there are some serious issues in the agriculture marketing industry which need attention from the government and other central bodies. While doing the research, the researcher found some significant issues that directly impact to Sri Lankan small scale farmers. The main challenge of the existing system is the lengthiness of current market channels. and unnecessary participation of

intermediate persons to a marketing process because these farmers are unable to get a reasonable price for their valuable crops. this project provides solutions to these issues by reducing the lengthiness of the marketing process. by connecting Farmers, buyers, and economic centers into one platform. EFMS shows the positive outcomes of the marketing process and it improves the effective efficiency of the Sri Lankan agro-economic sector and the project will provide feasible solutions for those identified problems in the agro-economy sector. And empower small scale farmers Sri Lanka Which is the main objective of the overall research.

### References

Development, R. and Unive, K. (2016) 'Dambulla Dedicated Economic Centre - a new Initiative in food marketing in Sri Lanka', (November).

Eds, P. Z., Conference, I. and Hutchison, D. (2013) LNCS 8029 - Online Communities and Social Computing.

'FACULTY OF SOCIAL SCINECES UNIVERSITY OF KELANIYA A study about problems that farmers face in trading Agri products to economic centers ) With special reference of Dambulla Dedicated Economic Center )' (2016), p. 2016.

FAO (1995) The farming systems approach to development and appropriate technology generation. Available at: <http://www.fao.org/docrep/v5330e/V5330e00.htm#Contents>.

Husemann, C. and Novkovic, N. (2014) 'Farm management information systems: A case study on a German multifunctional farm', *Ekonomika poljoprivrede*, 61(2), pp. 441-453. doi: 10.5937/ekopolj1402441h.

Karunarathna, K. and Vidanagama, D. U. (2015) 'E-farmer Management System for Agrarian Service Centre in Sri Lanka', (November).

'IoT Research and Development in Africa' (2010), 1(1).

Nayak, S. P., Shenoy, P. P. and Rajesh, S. (no date) 'An Integrated User Interface as Farmer ' s Assistant System', pp. 1-6.

Noel, O., Fernando, N. and Wikramanayake, G. (2014) 'Web Based Agriculture Information System', (October 1998).

Pramod, G. et al. (2016) 'E-farming', International Journal for Research in Applied Science and Engineering Technology, 4(1), pp. 204–207. Available at: <http://search.ebscohost.com/login.aspx?direct=true&db=lah&AN=20163094435&site=ehost-live%5Cnhttp://www.ijraset.com/files/serve.php?FID=3773>.

Silva, H. De and Ratnadiwakara, D. (no date) 'Using ICT to reduce transaction costs in agriculture through better communication: A case-study from Sri Lanka'.

### **Acknowledgment**

Researcher would like to acknowledge all the lectures of the Department of Information technology faculty of computing and all the other directors and officers of the Ministry of Rural Development and Hector Kobbekaduwa agrarian and Research center for the encouragement and supporting that they have extended

### **Author Biographies**



Piyumi Sandareka is undergraduate of General Sir John Kotelawala Defence University, faculty of computing Her research interest are in the fields of frontier Technologies, Business Process Reengineering, Knowledge Management. she has participated many research activities in university



Niroosha Wedasinghe graduated from London Metropolitan university-UK, and she has completed her Masters in CSU Australia. Currently, she is reading her Ph.D. in the KDU Postgraduate Faculty. Her research interests are in the field of Digital accessibility and Management Information Systems. She has published, reviewed, and supervised many researches nationally and internationally.



## Intensive Care Unit (ICU) Management System for Dengue Ward

WMCDK Weerakoon#, MMK Rowel, EMUWKM Abeyrathne, MDC Gunathilake, MR Kurukulasuriya and PPNV Kumara

*Faculty of Computing, General Sir John Kotelawala Defence University, Ratmalana, Sri Lanka*

# chavee1998@gmail.com

**Abstract:** Intensive care units(ICU) in Sri Lankan hospital systems are generally managed manually. Using a manual system for the ICU can cause many difficulties as the ICU is the main department in a hospital. After analysing the current procedure at Kalubowila Teaching Hospital we observed that it normally takes 24 hours to identify and direct a seriously ill dengue patient to the ICU from the High Dependency Unit(HDU). Patients with the Dengue virus will have similar symptoms. Thereby the next patient who needs to be admitted into the ICU has to be more ailing than the rest of the patients in the HDU. If the correct patient to be admitted is not identified, another patient in the unit could fall into a more severe case. ICU Management System is a web based system that has the ability to identify the next most critical Dengue patient that should be treated in the ICU using a specific score. The score is calculated by monitoring the symptoms of the patient and giving a separate value to each symptom. The calculated score depends on the severity of the patient. This paper presents the design and implementation of this ICU Management System and offers a comparative study about existing Hospital Management Systems.

**Keywords:** ICU, HDU, Score, Dengue, Hospital

### Introduction

Current hospital management system in Sri Lanka is not properly managed and most of the procedures and tasks are done manually using man power. When a patient is admitted to the hospital with symptoms of dengue fever it is hard to check whether the admitted

patient's situation is critical. The patient must go through several check-ups and tests in order to clarify whether he/she is in a severe condition (Soni et al., 2001). The process of directing patients to the ICU (Intensive Care Unit) is done manually by a doctor. The next patient to be selected has to be chosen from the HDU (High dependency Unit) which is also a manual process (Calvo Herranz et al., 2011). The current ICU management system faces many difficulties as it is done manually. Some of the difficulties, hospitals have to face are difficulties in finding the most rightful patient who should be treated in the ICU with better treatments, monitoring each and every patient's health situation and unable to find the most critical patient (Ward and Levy, 2001). After analysing the current situation on which the Intensive Care Unit (ICU) is being managed, a system was planned. With this system we plan to minimize the work of the 24 hour attendants in the ICU and to maximize the efficiency in taking them.

The intended system in an online, web-based system, which can show the next most suitable patient to be transferred to the ICU without any difficulties. Each patient will be given a specific score and using that score the severity of the patient is identified. Doctors and nurses will be able to manage this system conveniently, as it is easy to use.

### A. Problem in brief

The traditional method of directing a critically ill patient to the Intensive Care Unit (ICU) is performed on the recommendation of a physician. Manual examination of each patient is an exhausting procedure (“(7)

(PDF) Challenges encountered by critical care unit managers in the large intensive care units," n.d.). Some of the outcomes of dengue patients' infections requiring ICU admissions remain unclear. Therefore, it is difficult to identify critically ill patients who need to be treated in the ICU with specialized treatment (Chen et al., 2016). In the current system patients' records are stored manually in files, papers and bills. If a patient recovers from the disease and is discharged, but later is admitted again for the same disease and the records are not to be found it could be fatal as the disease could be more severe and without the right information and data of the patient. Treating the patient will not be an easy task. After storing the current records of the patient, to view them the doctor has to come and assess the patient regularly. While checking on the patient with the disease if the doctor realizes the disease has become fatal for the patient in an irregular tie period it could be a disaster. To avoid this matter would be the mission(" (7) (PDF) Management of dengue fever in ICU," n.d.).

#### B. Solution

As a solution to the above mentioned problems, an online web based system which can show the next most suitable patient that needs to be transferred to the ICU can be built using firebase. This system will be able to help physicians and nurses to monitor the severity of patients.

#### C. Aim and Objectives

The main aim of this project is to provide Kalubowila Hospital or any other general hospital an automated system to efficiently record dengue patients' data and find the most critical patient to be admitted to the ICU from HDU considering their health records.

In Sri Lanka, general hospitals do not have an automated system in the Intensive care unit. The proposed system's aim is to automate all the manual work done by the hospital staff and to gather the data and analyze important

information regarding patients. By considering the analysed data severity of the patient is identified and sorted in order to be treated in the ICU. Since there are two wards for serious patients, namely the HDU (High Dependency Unit) and the ICU (Intensive Care Unit) the system proposed will be used only between these two wards and also the patients switching is also done only in these two wards.

The method of evaluating the most critical patient in a very short period will be the main aim of this system. Within a short time period, using the recorded data of the patient, the system will be able to identify the next most critical patient to be admitted to the ICU.

The rest of the paper is organized as follows; section 2 contains related work by other pioneers and their views in this avenue of automating this system as well as information on the current manual system. Furthermore, section 3 provides a detailed description on the design and the implementation of the system along with its modules and methodology. Thereafter section 4 gives the general results. Last but not least the conclusion is described and discussed in section 5.

#### Related Works

There are many concepts developed which are used to automate ICU systems in hospitals but unfortunately, a working system as we proposed hasn't been developed progressively in the current world. As we proposed, we mentioned about the automatic score calculating technique and predicting the most suitable patient to admit to the ICU from the HDU unit and to compare the scores. However, there are some ICU management systems as mentioned below which comes under the existing techniques.

A. Therapeutic Intervention Scoring System (TISS)- A method for measuring workload and calculating costs in the ICU.

J. Malstam and L.Lind proposed the therapeutic intervention scoring system, which is an easily applicable method for measuring workload in the ICU. In the present day modified 'TISS' was performed during 1989-1998 on 2693 patients in a general ICU. From them only 900 could be treated in the ICU. The average workload was then calculated. The workload isn't related to age or type of admission from these calculations; patients categorized into respiratory and infectious diseases showed the greatest average workload. This workload index was developed relating the actual workload to the ICU personnel. This supports the potential cost saving managing patients in ICU (Kaufmann and Briegel, 2000).

Compared to the above stated system, the system we describe does not have a workload index. Instead, our system will be using algorithms to calculate accurately and precisely the next eligible and critical patient. In addition, this system will be able to assign and update the patient's medicine and hold the records (Kaufmann and Briegel, 2000).

B. Utilizing findings from the APACHE III research to develop an operational information system for the ICU-- the APACHE III ICU Management System.

The APACHE III database reflects the disease, physiologic status, and outcome data from 17,400 ICU patients at 40 hospitals. This provides a nationally representative standard for measuring several important aspects of ICU performance. Results from the study have now been used to develop an automated information system to provide real time information about expected ICU patient outcome, length of stay, production cost, and ICU performance. APACHE III has the capability to electronically interface with

and utilize data already captured in existing hospital information systems, automated laboratory information systems, and patient monitoring systems (Solutions, n.d.).

However, in our system we have used algorithms to predict and help to get the most important decisions. As we monitor the patients, the Sensors attached to the body track heart rate, blood pressure, and other vital signs, while bedside monitors graph the data in undulating lines. The ICU of the future will make far better use of its machines and the continuous streams of data they generate. Instead will pool their information to present a comprehensive picture of the patient's health to doctors. In addition, that information will flow to artificial intelligence (AI) like systems to predict the next most critical person in the ICU (Knaus et al., 1991).

C. ICU Care

ICU Care is built for Intensive Care Units as an information system. It was made for adults, neonatal, pediatric, and specialty intensive care. ICU Care is a domain specific, modularly oriented unit management and point of care information framework. The system is a solution to the software and hardware. In terms of applications, the framework provides Intensive Care Units with a forum for controlling clinical, administrative. This system gives the capacity to draw inferences and performance patterns of an ICU.

ICU Care functions as a bedside point of care system. Doctors use ICU Care to prescribe their patient's clinical process and care plan. This application is flexible to allow doctors to access patient's clinical reports from a different place. This system also communicates with other systems such as hospital information systems and PAC systems ("ICU Manager," n.d.).

The above stated system is built for adults, neonatal, pediatric and specialty intensive

care but the system we propose is built only for dengue patients.

#### D. Current Manual System

Most of the things in the hospital are done manually. Therefore, we have to compare our system with the manual existing process, which is undergoing in each hospital in Sri Lanka. As we mentioned earlier we are proposing our automated ICU managing system to the dengue unit of the Kalubowila Teaching Hospital

The initial step of the manual process starts with entering the patient's data when admitting to the hospital, from then on patients are being monitored, and data is being added daily to the patients' records. In case if the patient's condition gets serious then only the patient will transfer to the high dependency unit and at that time also the data is being gathered and no any score or prediction is taking place. If the situation is getting worse, there is no chance to transfer the patient to the ICU unless there is an available bed because we can't compare the patient and select the most suitable patient to be admitted or to remain in the ICU. A survey was conducted to acquire information about the current manual system that is being commonly used. 15 medical personals were selected from the Kalubowila Teaching Hospital.

The medical personnel were initially asked about their opinion on the development of the IT field in the current hospital system.

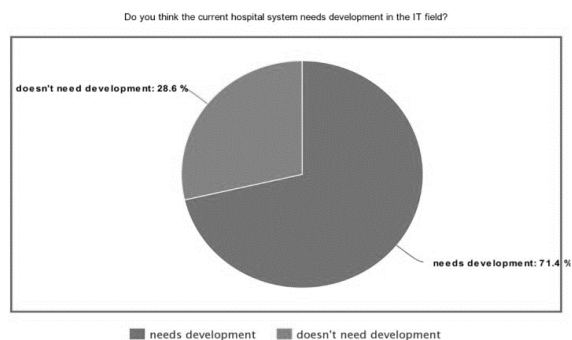

Figure 1 – Question 1 statistical results

According to the above pie chart it clearly shows how the medical personnel think of the current system in which the IT department may use. The positive response of the participants is mainly due to the human error that could occur under immense pressure when rash decisions have to be made. When decisions are made, statistics should be analysed and taken care of, therefore an effective system to output continuous data for the medical team would be of immense help. Thereby the It department of the hospital has to be point and the algorithm has to be effective. The minority which would be the negative response is due to the participants thinking that the human brain can judge better than a computerized algorithm. Since the AI field is still being developed all over the world the concept in this field is not famous. Thereby the participants believed that the human judgment should overrule the algorithm when necessary and this moment is not specified (Gholami et al., 2018). It could be whenever or through the continuous path. Hence, after reviewing existing technologies the proposed system was designed and developed

#### Design & Implementation

Addressing the main problem and reviewing the current technologies, the proposed solution is an automated ICU management system. ICU management system is a web based system which is built using Java and uses firebase as the database connector.

This web page can be considered as the “user-interface” of the system and hence used to interact with the system. To capture changes and to keep the system synchronized with the web page, Firebase platform is used. To understand the system purpose in depth, main functionalities of the system are listed below.

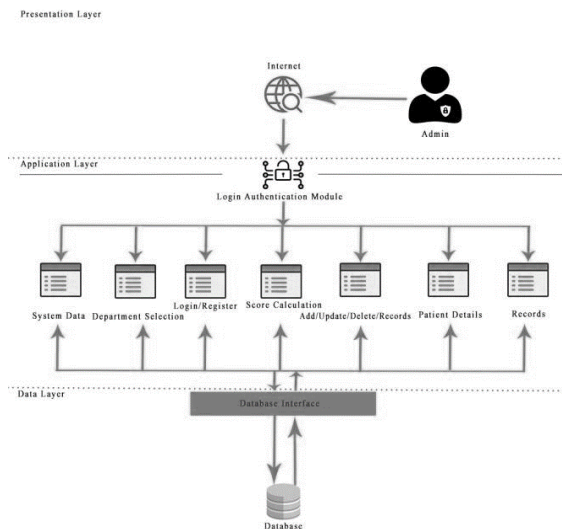

Figure 2 – Overall System Architecture

#### A. Calculate the score

To identify the severity of each patient individually, a specific score is calculated using an algorithm. By monitoring and giving a score to each and every patient in the ICU and HDU, ICU Management System gives the ability to find the most severe patient and direct him/her to the rightful unit.

#### B. Doctors score

There's a special section only for doctors, so that the doctors could give a score to all the patients separately. The doctor's score will also be added to the final score of the patient. This score is given according to the doctor's experience on the patients and physically visible symptoms are considered when giving this score. And also other medical conditions of the patient and the facts which cannot be included in the system are considered here. A separate percentage from the final score is calculated with this doctor's score.

#### C. Real time status module

Firestore database system is capable of capturing real time changes that occur in the application. Therefore, when a new patient is admitted to the hospital and when the nurse inputs his details to the system, the real time status of the specific patient will be displayed. Also when a patient's condition

changes from one state to another it will also be displayed in the system.

#### D. Update records

Keep an updated detailed record of the doctors' comments, tests, scans and most importantly the patients score. Here according to the data collected the patients score gets updated and again gets sorted according to the highest score. So that the doctors get an alert saying the patient with the highest score needs to be transferred to the ICU. If any patient in the ICU gets a score which is below than a patient in the HDU, then both the patients should be interchange. Likewise, when a new patient or a new data is added to the system it gets updated and sorted accordingly by always displaying the most critical person.

#### E. Alerts

When a patient's score gets higher than expected which means that the patient should be immediately transferred into the ICU, so in that kind of a situation an alert is sent to all medical personals which are responsible for the patient. And also when a patient from ICU gets a lower score than a Patient in the HDU, then another alert is sent by mentioning the availability of the ICU.

The proposed system will be the most suitable and efficient model to be used in hospitals as it is necessary. Hospital personnel such as doctors and ward attendants will use the system only. Since there are two wards of focus namely the HDU (High Dependency Unit) and the ICU (Intensive Care Unit) the system proposed will be used only between these two wards.

The relevant administrator logs in to enter the new patients details and personal information. After that, the data regarding the symptoms and phases of the dengue disease is recorded and stored. The method of evaluating the most critical patient in a very short period will be the goal of this

system. After discussing with the doctors of Kalubowila teaching hospital each symptom is given a specific score accordingly, so by that calculation within a short period of time with the recorded information of the patient, the system will be able to select the next most suitable patient to the ICU.

ICU Management System is developed to improve the efficiency of intensive care unit which will provide services with in and out of the hospital environment uplifting a better health care system with lesser maintain cost and manpower, mainly and easier to use system that's user friendly in order to make the hospital staff less stressful and to make a happier working environment. Even though the system was initially designed to cover the entire hospital management system but since hospitals have a very large organizational structure, with the time limitations for the development of projects, the system will be initially developed only for the intensive care unit of the dengue ward.

### Result & Discussion

In Sri Lanka, the general hospitals do not have an automated system to be used in an Intensive care unit. The proposed system will be the most suitable and efficient model to be used in hospitals as it is necessary. Hospital personnel such as doctors and ward attendants will use the system only. Since there are two wards of focus namely the HDU (High Dependency Unit) and the ICU (Intensive Care Unit) the system proposed will be used only between these two wards.

In order to understand user reaction to the proposed system, the system was presented to few users. Also a questionnaire was presented to them to acquire feedback about the system. Before presenting the system to users we provided a survey to a few selected users to get their opinion.

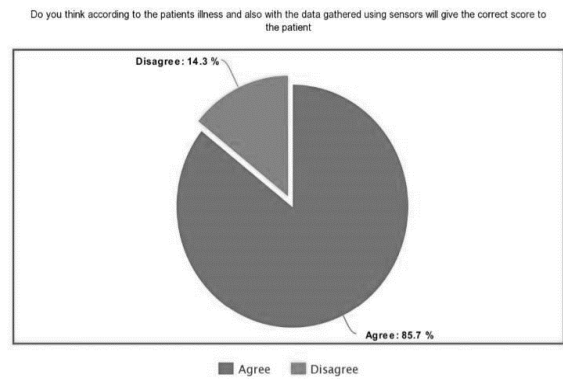

Figure 3 – Question 2 statistical results

According to the above pie chart when the score is calculated with the relevant sensors the accurate score entitled to each patient can be calculated.

Do you think giving a Score to each patient will solve the problem in selecting the most critical patient?

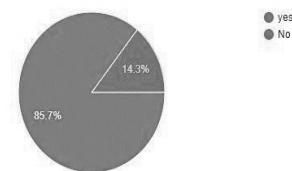

Figure 4 – Question 3 statistical results

According to the feedback users have given, it is proved that our proposed system would be useful for hospitals (“Yoodly ICU Management System,” n.d.).

The users were first briefed about the functionality of the system and given to test the system.

The relevant user logs in to enter the new patients details and personal information. After that, the data regarding the symptoms and phases of the dengue disease is recorded. These details recorded and stored in such a manner would be very useful in this industry as it is time to develop has come. Users agreed that since every procedure will be done online very soon, this system will be of good use to the general hospital.

Through this test, it was evident that the functionality of the system fulfils the set-out objectives.

The method of evaluating the most critical patient in a very short period will be the goal of this system. In no time with the recorded information of the patient, the system will be able to make out the next most suitable patient to the ICU.

### Conclusion

Intensive care unit(ICU) in the Sri Lankan hospital system is generally managed manually. Using a manual system for the ICU can cause many difficulties. To overcome the problems which have occurred in an intensive care unit (ICU) such as difficulties in finding the next rightful patient who should be treated in the ICU, finding the most critical patient in ICU and difficulties in monitoring the patient's health and treatments. The system to automate the current ICU procedure provides an effective platform to both doctors and nurse to identify the next most suitable patient that should be treated in the ICU using a specific score. Since the process is automated through the system, the main issues of a present ICU system will be fixed. Therefore, our system is basically focusing on dengue patients and monitoring them to get the score and sorting them according to a specific order to transfer patients to the ICU from HDU in the dengue ward. ICU management system is a web based system that uses firebase as the database connector. This paper presents the design and implementation of this ICU Management System and offers a comparative study about existing Hospital Management Systems.

### Further Works

Further, the system can be expanded to achieve the scope of the development. Following are identified as the further enhancement to be attached to the implemented system.

- Expanding the system to every high dependency unit in every ward.

- Use the system to predict the most suitable patient to be admitted to the HDU.
- Merging the doctors in every ward to the system so any on duty doctor will monitor the patients in the ICU in any serious case.
- Send automatic calls to doctors in serious situation

### Acknowledgement

We would like to acknowledge everyone including our supervisor Mr. PPNV Kumara who assisted in conducting this research.

### References

- Calvo Herranz, E., Mozo Martín, M.T., Gordo Vidal, F., 2011. Introduction of a management system in Intensive Care Medicine based on the safety of the seriously ill patient during the entire hospitalization process: Extended Intensive Care Medicine. *Med. Intensiva Engl. Ed.* 35, 354–360. <https://doi.org/10.1016/j.medine.2011.05.002>
- Gholami, B., Haddad, W.M., Bailey, J.M., 2018. AI in the ICU: In the intensive care unit, artificial intelligence can keep watch. *IEEE Spectr.* 55, 31–35. <https://doi.org/10.1109/MSPEC.2018.8482421>
- Kaufmann, I., Briegel, J., 2000. Therapeutic Intervention Scoring System (TISS) - a method for calculating costs in the intensive care unit (ICU) and intermediate care unit (IMCU). *Crit. Care* 4, P243. <https://doi.org/10.1186/cc962>
- Knaus, W.A., Draper, E.A., Wagner, D.P., 1991. Utilizing findings from the APACHE III research to develop operational information system for the ICU--the APACHE III ICU Management System. *Proc. Annu. Symp. Comput. Appl. Med. Care* 987–989.
- Solutions, P.C., n.d. ICU Software: Critical Care Management Solution. Picis. URL <https://www.picis.com/solution/governmentsuite/critical-care-manager/> (accessed 7.30.20).
- Yoodly ICU Management System [WWW Document], n.d. . CodeCanyon. URL <https://codecanyon.net/item/yoodly-icu-managementsystem/11814705> (accessed 7.30.20).

(7) (PDF) Challenges encountered by critical care unit managers in the large intensive care units [WWW Document], n.d. . ResearchGate. URL [https://www.researchgate.net/publication/262382197\\_Challenges\\_encountered\\_by\\_critical\\_care\\_unit\\_managers\\_in\\_the\\_large\\_intensive\\_care\\_units](https://www.researchgate.net/publication/262382197_Challenges_encountered_by_critical_care_unit_managers_in_the_large_intensive_care_units) (accessed 9.8.20).

(7) (PDF) Management of dengue fever in ICU [WWW Document], n.d. . ResearchGate. URL [https://www.researchgate.net/publication/11588083\\_Management\\_of\\_dengue\\_fever\\_in\\_ICU](https://www.researchgate.net/publication/11588083_Management_of_dengue_fever_in_ICU) (accessed 9.8.20).

Chen, C.-M., Chan, K.-S., Yu, W.-L., Cheng, K.-C., Chao, H.- C., Yeh, C.-Y., Lai, C.-C., 2016. The outcomes of patients with severe dengue admitted to intensive care units. *Medicine (Baltimore)* 95, e4376. <https://doi.org/10.1097/MD.0000000000004376>

ICU Manager [WWW Document], n.d. URL <http://www.precepthealth.com/webcontent/precept/Products/ICUManager/tabid/108/Default.aspx> (accessed 9.8.20).

Kaufmann, I., Briegel, J., 2000. Therapeutic Intervention Scoring System (TISS) - a method for calculating costs in the intensive care unit (ICU) and intermediate care unit (IMCU). *Crit. Care* 4, P243. <https://doi.org/10.1186/cc962>

Soni, A., Chugh, K., Sachdev, A., Gupta, D., 2001. Management of dengue fever in ICU. *Indian J. Pediatr.* 68, 1051– 1055. <https://doi.org/10.1007/BF02722356>

Ward, N.S., Levy, M.M., 2001. Clinical Information Systems in the ICU, in: Vincent, J.-L. (Ed.), *Yearbook of Intensive Care and Emergency Medicine 2001, Yearbook of Intensive Care and Emergency Medicine 2001*. Springer, Berlin, Heidelberg, pp. 685–694. [https://doi.org/10.1007/978-3-642-59467-0\\_56](https://doi.org/10.1007/978-3-642-59467-0_56)



## Improving Web Service Recommendation using Clustering and Model-Based Methods

LRMAM Weerasinghe<sup>1#</sup> and RAHM Rupasingha<sup>2</sup>

<sup>1</sup> Faculty of Applied Sciences, Sabaragamuwa University of Sri Lanka,

<sup>2</sup> Faculty of Social Sciences and Languages, Sabaragamuwa University of Sri Lanka

# lrmamweerasinghe@gmail.com

**Abstract:** With the development of the world wide web (WWW), the number of people who can deal with their work through the Internet, is increasing and it helps to do their tasks effectively and efficiently. In this case, a very important task is fulfilled by Web services. But the main problem is users struggling to select their favourite Web services quickly and accurately among available Web services. Web service recommendations help to solve this problem successfully. In this paper, we used collaborative filtering (CF)-based recommendation technique, but it suffers from the data sparsity and cold-start problem. Therefore, we applied an ontology-based clustering approach to overcome these problems. It effectively increased the data density by assuming the missing user preferences comparing the history of user favoured domains. Then, user ratings are predicted based on the model-based approach such as singular value decomposition (SVD). The result showed that the clustering approach can overcome the CF problems effectively and the SVD method can predict user ratings with lower prediction error compared with existing approaches.

**Keywords:** Web services, Recommendation, Collaborative filtering, Singular value decomposition, Sparsity, Cold-start

### Introduction

Web services are software components that help to communicate between one computer to another computer through the Internet for data and information exchanging. In day by

day, a large number of new Web services are coming to the Internet and that services support to develop some products or services. But most developers or users are struggling to find matching Web services. Therefore, the recommendation has a highly important place within the Internet users that discover services effectively and efficiently. In Web service recommendation that also suggests the best recommended services for users.

In the classification of recommendation (Adomavicius and Tuzhilin, 2005), there are three types of recommendation approaches such as content-based (Shoval, Maidel and Shapira, 2008), CF (Han et al., 2012), (Rupasingha and Paik, 2019) and hybrid filtering (Melville, Mooney and Nagarajan, 2002), (Li et al., 2010). The content-based approach contains some drawbacks (Li et al., 2010) and one of the main problems is that it needed users' personal information. And content-based techniques require the specification of a complete profile for each user/item. In CF core assumption is that users who have expressed similar interests in the past will share common interests in the future. The hybrid filtering is a combination of content-based and CF. Today one of the most successful and widely used methods in recommender systems is CF. The proposed approach is a CF and CF methods are divided into two types of recommendation techniques such as memory-based and model-based methods. Memory-based approaches use a database of past knowledge

to infer the active user's preference for an item. We selected our CF approach as a model-based approach (Jia, Feng and Yu, 2010) that operate in two phases: the rating matrix is used in the offline phase to learn a compact configuration model for each user; the model is then used in an online phase to predict the user's level of interest in candidate items. Always use statistical and machine learning methods to learn the model from a dataset. Such algorithms can generate a recommendation that has the promise of being highly scalable while producing good predictive accuracy. The proposed approach is a model-based CF algorithm it presents using matrix factorization.

In any case, CF faced some major problems. Those are data sparsity, cold start, system scalability, synonymy, and shilling attack. In this approach, we focus on data sparsity and cold start problems. These problems arise because of insufficient prior transactions and available feedback data which makes it difficult to recognize similar users. There were many efforts to reduce the issues of sparsity and cold-starting. Transitive association-based methods (Shoval, Maidel and Shapira, 2008), clustering-based methods (Rupasingha and Paik, 2018a), (Rupasingha and Paik, 2019), (Melville, Mooney and Nagarajan, 2002) that decrease dimensionality by latent semantic indexing, binary preference-based methods (Ghauth and Abdullah, 2010), and correlation and cosine-based techniques (Han et al., 2012), give good performance for recommendations while reducing sparsity. In our approach, we used to resolve these recommendation issues by applying a clustering-based method that efficiently and effectively decreases the user rating dataset's data sparsity. Although there are several clustering methods (Rupasingha and Paik, 2015), (Rupasingha et al., 2016) available, we used a specificity-based novel ontology generation method as a clustering approach to classifying the service cluster

groups (Rupasingha and Paik, 2019), (Rupasingha, Paik and Kumara, 2017). Because this approach showed the best performance of high precision, recall & F-measure rather than other existing clustering approaches and it successfully reduces the sparsity problem in the user service data-set.

After alleviating the sparsity using the clustering method, we used a model-based method to predict the user ratings. In model-based recommendation, we applied SVD for the CF process since it shows better performance when comparing with other model-based approaches. The SVD can capture the latent relationship between users and services. That allows us to compute the likeliness of a certain service by a user. Otherwise, SVD can produce a low dimensional representation of the original user-service space. Those predicted ratings from the SVD used for the recommendation.

We used mean absolute error (MAE) and root mean square error (RMSE) for calculating the accuracy of the predicted dataset and compared it with three types of sparsity levels. The proposed recommendation mechanism shows a lower error rate in MAE and RMSE comparing with existing methods.

This paper has been organized as follows. The second section is related work, the third section is the motivation, the fourth section is the overview of the proposed recommendation approach, the fifth section is experiments and evaluations, the sixth section is the conclusion and future work.

## Related Work

### A. Collaborative Filtering

CF (Han et al., 2012), (Rupasingha and Paik, 2019), is used to recommend a new service of interest for a particular user based on other users' opinions. This is depending on the user rating matrix analyzing. The assumption is that "users who adopted the same behavior in

the past will tend to agree also in the future” (Nicola Barbieri, Giuseppe Manco, 2014).

CF approaches (Nicola Barbieri, Giuseppe Manco, 2014) may be classified specifically memory-based and model-based methods. Each class considers the preference matrix. However, memory-based methods infer the preference of the active user for an item by using a database of past knowledge. Among memory-based approaches, an outstanding role is contended by neighborhood-based methods (Hu, Peng and Hu, 2014), that are based on the definition of similarity between user or item. Memory-based approaches (Chen et al., 2010) are intuitive, as they directly rework hold on preference knowledge into predictions. The drawback is that they have access to the entire dataset to make recommendations, and, thus, they require specific indexing techniques, particularly when the scale of the data will increase. In contrast, model-based approaches (Chen et al., 2010) operate in two phases: within the off-line phase, the rating matrix is used to learn a compact personalization model for every user; then, the model is used in an on-line phase to predict the degree of interest of the user on candidate items. That approach (Nicola Barbieri, Giuseppe Manco, 2014) needs access to only a compact representation of the data. However, the recommendation provided to the user might not be simply explicable. A fundamental distinction also depends on the type of relationships among users and items that they're ready to exploit. Model-based approaches usually use dimensionality reduction techniques and therefore concentrate on the estimation of weak however global relationships.

Since the drawback of memory-based, we selected Probabilistic methods (Koren, Bell and Volinsky, 2009) which are the main focus of this manuscript, represent a refinement of the model-based approach, that relies on probabilistic modelling each in the learning

phase and the prediction phase. In (Ramesh, Rao and Govardhan, 2017), show that model-based have different techniques Bayesian network, artificial neural network, and matrix factorization. In (Koren, Bell and Volinsky, 2009), visualized these techniques according to the MAE and RMSE. Through this result, it shows SVD generate high accurate result quickly. Therefore, we selected the SVD recommendation technique to continue our research.

## B. Challenges of Collaborative Filtering

The CF used to data recommendations based on user-service ratings. Increasing the number of users and services help for some problems. If the dataset filled with null values, it becomes a reason for all users to do not interact with the rating mechanism. Therefore, the sparsity problem occurs. Otherwise, new users or items come to the system CF cannot recommend that. Therefore, cold-start problems occur. Because of these problems, it is challenging to find relations between users and services. Therefore, we want to make an effective recommendation.

### 1) Data Sparsity Problem:

In CF, sparsity is the main problem. That reduces the performance of the CF. To overcome this problem there are some existing researches. In (Rupasingha and Paik, 2019), address sparsity problem using the specificity aware ontology-based clustering and it improves recommendation performance. In (Chen, 2011), they fulfilled the sparsity problem using association retrieval technology and improve the recommendation result. In (Li et al., 2017), using the simplified method, that improved the performance and reduce the sparsity of the recommendation.

### 2) Cold Start Problem:

In cold start problem, there are no any user-service available ratings in their profiles. In (Bobadilla et al., 2012), they used CF for alleviating to the cold start problem. And in

(Ahn, 2008) they used heuristic similarity measure and then alleviate the cold start problem.

Users	Web Services							
	S1	S2	S3	S4	S5	S6	S7	S8
U1	1	0	1	0	0	0	0	0
U2	0	0	0	0	0	0	1	0
U3	1	0	0	1	0	0	0	1
U4	0	0	0	0	0	0	0	0
U5	0	0	0	1	0	0	0	0
U6	0	0	0	0	0	1	0	0
U7	0	1	0	0	0	0	0	1

Figure 20. User-Service rating matrix

### Motivation

As discussed in the previous section, Web service recommendations face some problems such as data sparsity because users are not rating for services and cold-start problems because of new users and/or services coming for the recommendation. Since that case recommendation systems occur wrong predictions. Therefore, that system has low accuracy.

In Figure 1 explains 7 users and 8 Web services with their ratings. And it's all users do not interact with the rating system. So, if we have a large number of user-service ratings it is not easy to generate good accurate prediction results.

#### A. Example of Data Sparsity Problem

In Figure 1, let active U6. Its interesting service is S6. Then if we find who likes to S6, but no one likes it. Therefore, the system struggles to generate prediction results. This happens because of the data sparsity problem.

#### B. Example of Cold Start Problem

Let get U4 and S5, that are not active yet. Since that have not information about their relations the system cannot generate prediction results. It called a cold-start problem.

In Web service recommendation has above sparsity and cold start problems. So, it motivates us to find a method to overcome those problems. Because those problems occur wrong predictions and therefore, users waste their valuable time for searching their needs.

We found by comparing the existing recommendation research papers that SVD shows better results. Therefore, we wanted to resolve the above problems using clustering and then apply SVD for improving recommendation results

### Overview of The Proposed Recommendation Approach

The architecture of the proposed approach is shown in Figure 2. In there, firstly collect the user-service data set and then get new data set by reducing sparsity using the ontology-based clustering method (Rupasingha and Paik, 2019). Then SVD is applied to the new data set for users' rating prediction. The recommendation is based on these prediction results.

#### A. Sparsity Alleviating

As shown in Figure 2, sparsity alleviates using the clustering is the first part. We used

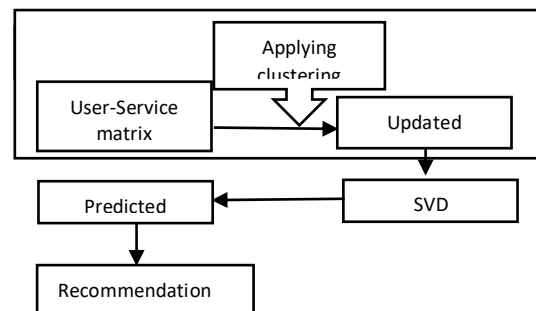

Figure 2. Architecture of the proposed method for recommending web services

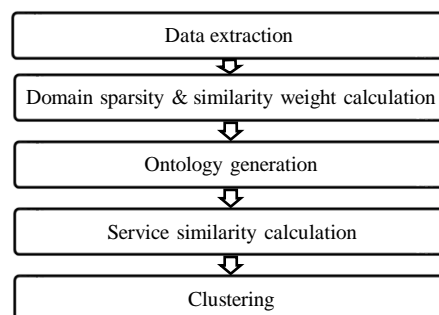

Figure 3. Ontology-based clustering method

a specificity-aware ontology generation-based clustering approach for (Rupasingha, Paik and Kumara, 2018) sparsity alleviating. Because it shows better clustering results

rather than other approaches. In Figure 3, shows the process of ontology-based clustering.

For ontology generation, they used real Web services from the Web services repositories and Web Ontology Languages for Services (OWL-S)

(<http://projects.semwebcentral.org/project/s/owls-tc/>). It has Web Service Description Language (WSDL) documents and selected the five domains related to Book, Food, Film, Vehicle, and Medical. See Figure 3. Firstly data extracted as service name, operation

$$\hat{r}_{us} = \mu + b_u + b_s + q_s^T \cdot p_u \quad (2)$$

name, port name, input, and output messages form WSDL documents. Then do the domain specificity and similarity weight calculations and through this calculation generates the ontology. After calculating service similarity using this ontology finally got cluster results and grouped Web services into the above five clusters.

Using this clustering approach, we alleviate the sparsity (Rupasingha and Paik, 2019) as shown in Figure 4. Figure 4 explains the process of sparsity alleviating.

In the user-service rating dataset, we can see that 1 to 5 possible ratings and 0 means that user  $u$  not previously invoke with Web service  $s$ . then  $r_{us} = 0$ .

$$r_{us} \begin{cases} r, & r = 1,2,3,4,5 \text{ if user } u \text{ rated service } s, \\ 0, & \text{otherwise} \end{cases}$$

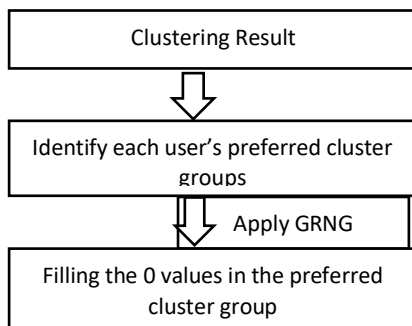

Figure 4. Sparsity alleviating process

We used this clustering result with Gaussian random number generation (GRNG) for filling the 0 values. Then, we used this result for rating prediction with the SVD method.

### B. Rating Prediction

After sparsity alleviating then we improved our result using the SVD. The SVD technique is a simple matrix factorization method. We have selected it because the SVD (Solvang, 2017) is a good recommendation algorithm compare with other algorithms and it easily improves recommendation results.

In our SVD calculation the prediction  $\hat{r}_{us}$  is set as:

$\mu$  – mean normalization

$b_u, b_s$  - Observed deviation of user  $u$ , service  $s$

If user  $u$  is unknown, then the bias  $b_u$  and the factors  $p_u$  are assumed to be zero. The same applies for service  $s$  with  $b_s$  and  $q_s$ .

To estimate all the unknown, we minimize the following regularized squared error

$$\sum_{r_{us} \in R_{Train}} (r_{us} - \hat{r}_{us})^2 + \lambda(b_s^2 + b_u^2 + \|q_u\|^2 + \|p_u\|^2)$$

The minimization is performed by a very straightforward stochastic gradient descent:

$$\begin{aligned} b_u &\leftarrow b_u + \gamma(e_{us} - \lambda b_u) \\ b_s &\leftarrow b_s + \gamma(e_{us} - \lambda b_s) \\ p_u &\leftarrow p_u + \gamma(e_{us} \cdot q_s - \lambda p_u) \\ q_s &\leftarrow q_s + \gamma(e_{us} \cdot p_u - \lambda q_s) \end{aligned} \quad (1)$$

In there;

$\gamma$  = learning rate

$\lambda$  = regularization term

$r_{us}$  = training dataset

$e_{us}$  = error of training and predicted dataset

$R_{Train}$  = set of the  $(u,s)$  pairs for which  $r_{us}$  is known

All the user ratings are predicted by the SVD and top ratings are used for service recommendation.

## Experiments and Evaluations

We used Python as a language for SVD-based recommendation. For the implementation, we used the Surprise package (Hug, 2017).

First, we collect input user-service ratings. In this dataset, we simulated 200 users' ratings using 400 real Web services from real Web service repositories and OWL-S (<http://projects.semwebcentral.org/project>

$$\text{Sparsity level} = \frac{\text{Number of Non specified ratings}}{\text{Number of all possible ratings}} \quad (5)$$

s/owl- tc/). For this real Web services, we couldn't find real recommendation data. Therefore, we used a simulated dataset, it is already used in (Rupasingha, Paik and Kumara, 2018), (Rupasingha and Paik, 2018b). We could trust this dataset since, in their observation, they proved this simulated dataset have high accuracy with their evaluations. In their experimentation, they applied GRNG to generate the simulated dataset. That helps to easily evaluate our results. Evaluation based on MAE and RMSE. For sparsity alleviation and rating prediction, we used three sparsity levels that are 55%, 70%, and 85%.

MAE is measuring the deviation of the prediction and RMSE is the square root of the average of squared differences between prediction and actual observation. Better predictions visualized by the smaller MAE and RMSE values.

$r_{u,s}$  = training dataset user  $u$ , on service  $s$   
 $\hat{r}_{u,s}$  = predicted dataset user  $u$ , on service  $s$   
 $s$  = Web services

$$MAE = \frac{1}{N} \sum_{s=1}^N |r_{u,s} - \hat{r}_{u,s}| \quad (6)$$

$$RMSE = \sqrt{\frac{1}{N} \sum_{s=1}^N (r_{u,s} - \hat{r}_{u,s})^2} \quad (7)$$

$N$  = number of predicted values

### A. Evaluation Based on Sparsity Alleviating

We measure our recommendation performance using three sparsity levels (55%, 70%, and 85%). In Figure 5, that visualized number of non-rated values before and after alleviating sparsity.

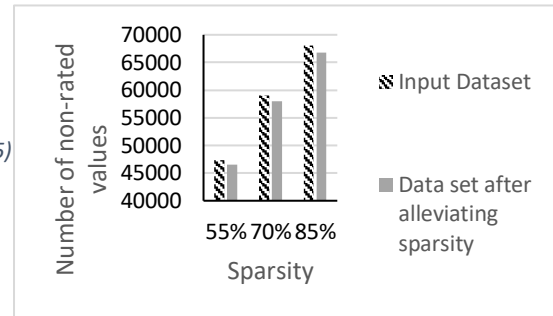

Figure 5. Number of non-rated values before and after alleviating sparsity

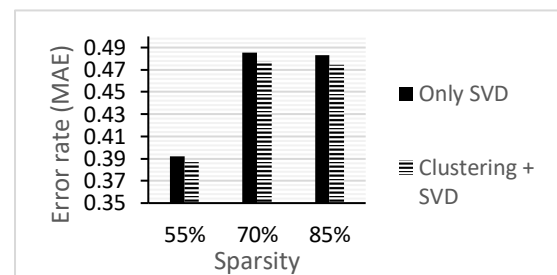

Figure 6. MAE for with and without clustering

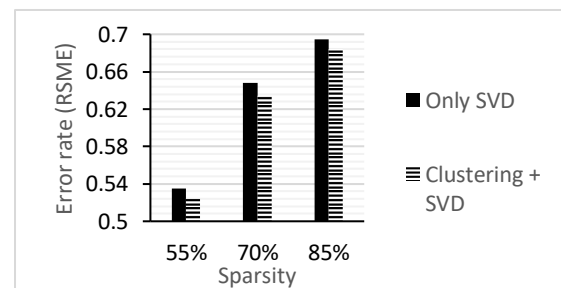

Figure 7. RMSE for with and without clustering

After alleviating the sparsity, we used SVD for rating prediction. Figure 6, and Figure 7, show that MAE, and RMSE values for prediction results with and without alleviating sparsity through the clustering method. That results also compared with three sparsity levels. However, it presents a lower error rate in SVD with a clustering method in a 55% sparsity level than other results. And if the dataset has a lower

sparsity level, that generates a highly accurate result. Through this result we can suggest sparsity alleviating by clustering is successfully improve the recommendation performance.

### B. Evaluation Based on Comparison with Existing Methods

We compare our method with the following three existing methods that are applied sparsity alleviation methods in recommendation.

Ontology-based clustering with Pearson correlation coefficient (PCC) (Rupasingha and Paik, 2019), They divided their Web services into five clusters and then applied GRNG for reducing to the sparsity. Then used PCC to improve to recommendation result. Association retrieval method (Chen, 2011), used the user’s feedback data and calculate the relative distance between users’ rating and similarity matrix then combined these and alleviating the sparsity problem. The binary method (Li et al., 2017), used a simplified similarity measure (SSM) method for fulfilling to sparsity problem. They convert user-item rating values into binary values, it helps to find similar users and therefore SSM, that speed up the process.

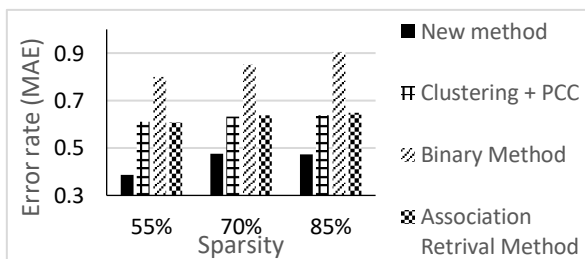

Figure 8. Evaluation based on comparison with existing methods (MAE)

We compared these methods and that shown in Figure 8 and Figure 9. According to the results, our proposed method shows better performance with minimum MAE and RMSE values. According to the evaluation result, using the ontology-based clustering result,

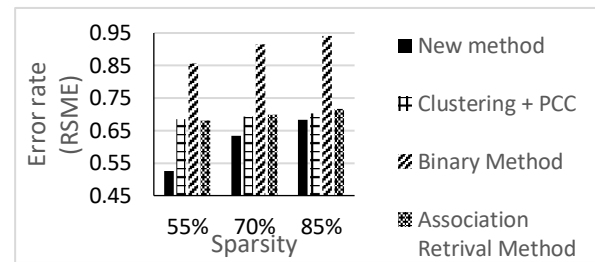

Figure 9. Evaluation based on comparison with existing methods (RSME)

we could successfully address the data sparsity problem. And in the cold start problem Web services identified by the clustering domain and if less than five ratings from users, we consider it as a cold start problem. We could overcome those problems successfully and finally compare with the existing methods we can show our approach improves the recommendation performance.

### Conclusion and Future Work

Reason for the data sparsity and cold-start problems, existing Web service recommendation approaches have low performance. Therefore, our main objective is improving the recommendation result to reduce the lack of quality on the recommendation. In our proposed method we deal with these problems. We used ontology-based clustering for reducing the sparsity of the user-service rating matrix. Then we applied the SVD to rating predictions and it helps to improve the recommendation results. Through the clustering that reduces data sparsity and cold start problems successfully, and the lowest error rate verifies that our approach has high accuracy and best recommendation performance. In our future research, we aim to apply SVD++ for Web service recommendation and improve the recommendation performance.

### References

Adomavicius, G. and Tuzhilin, A. (2005) ‘Toward the next generation of recommender systems: A survey of the state-of-the-art and possible extensions’, IEEE Transactions on Knowledge and

- Data Engineering, 17(6), pp. 734–749. doi: 10.1109/TKDE.2005.99.
- Ahn, H. J. (2008) 'A new similarity measure for collaborative filtering to alleviate the new user cold-starting problem', *Information Sciences*, 178(1), pp. 37–51. doi: 10.1016/j.ins.2007.07.024.
- Bobadilla, J. et al. (2012) 'A collaborative filtering approach to mitigate the new user cold start problem', *Knowledge-Based Systems*, 26, pp. 225–238. doi: 10.1016/j.knosys.2011.07.021.
- Chen, X. et al. (2010) 'RegionKNN: A scalable hybrid collaborative filtering algorithm for personalized web service recommendation', *ICWS 2010 - 2010 IEEE 8th International Conference on Web Services*, pp. 9–16. doi: 10.1109/ICWS.2010.27.
- Chen, Y. (2011) 'Solving the Sparsity Problem in Recommender Systems Using Association Retrieval', 6(9), pp. 1896–1902. doi: 10.4304/jcp.6.9.1896-1902.
- Ghauth, K. I. and Abdullah, N. A. (2010) 'Learning materials recommendation using good learners' ratings and content-based filtering', *Educational Technology Research and Development*, 58(6), pp. 711–727. doi: 10.1007/s11423-010-9155-4.
- Han, X. et al. (2012) 'A Big Data Model Supporting Information Recommendation in Social Networks', in *2012 Second International Conference on Cloud and Green Computing*. IEEE, pp. 810–813. doi: 10.1109/CGC.2012.125.
- Hu, Y., Peng, Q. and Hu, X. (2014) 'A time-aware and data sparsity tolerant approach for Web service recommendation', *Proceedings - 2014 IEEE International Conference on Web Services, ICWS 2014*, pp. 33–40. doi: 10.1109/ICWS.2014.18.
- Hug, N. (2017) *Surprise*, a Python library for recommender systems. Available at: [surpriselib.com](http://surpriselib.com).
- Jia, Z., Feng, Q. and Yu, J. (2010) 'A service model based on recommendation trust in pervasive computing environment', *ICPCA10 - 5th International Conference on Pervasive Computing and Applications*, pp. 393–397. doi: 10.1109/ICPCA.2010.5704134.
- Koren, Y., Bell, R. and Volinsky, C. (2009) 'COVER FE AT U RE MATRIX TECHNIQUES FOR', pp. 30–37.
- Li, L. et al. (2010) 'A contextual-bandit approach to personalized news article recommendation', *Proceedings of the 19th International Conference on World Wide Web, WWW '10*, pp. 661–670. doi: 10.1145/1772690.1772758.
- Li, L. et al. (2017) 'A Simplified Method for Improving the Performance of Product Recommendation with Sparse Data', (*iCAST*), pp. 318–323.
- Melville, P., Mooney, R. J. and Nagarajan, R. (2002) 'Content-boosted collaborative filtering for improved recommendations', *Proceedings of the National Conference on Artificial Intelligence*, pp. 187–192.
- Nicola Barbieri, Giuseppe Manco, E. R. (2014) *Probabilistic Approaches to Recommendations Synthesis Lectures on Data Mining and Knowledge Discovery*. Available at: <http://www.morganclaypool.com/doi/abs/10.2200/S00574ED1V01Y201403DMK009>.
- Ramesh, C., Rao, K. V. C. and Govardhan, A. (2017) 'Ontology based web usage mining model', *Proceedings of the International Conference on Inventive Communication and Computational Technologies, ICICCT 2017, (Icicct)*, pp. 356–362. doi: 10.1109/ICICCT.2017.7975219.
- Rupasingha, R. A. H. M. et al. (2016) 'Domain-aware web service clustering based on ontology generation by text mining', *7th IEEE Annual Information Technology, Electronics and Mobile Communication Conference, IEEE IEMCON 2016, (October)*. doi: 10.1109/IEMCON.2016.7746301.
- Rupasingha, R. A. H. M. and Paik, I. (2015) 'Calculating Web Service Similarity using Ontology Learning with Machine Learning', *2015 IEEE International Conference on Computational Intelligence and Computing Research (ICIC) (pp. 1-8)*. IEEE.
- Rupasingha, R. A. H. M. and Paik, I. (2018a) 'Evaluation of Web Service Recommendation Performance via Sparsity Alleviating by Specificity-Aware Ontology-Based Clustering', *2018 9th International Conference on Awareness Science and Technology, iCAST 2018*. IEEE,



(September 2018), pp. 279–284. doi: 10.1109/ICAwST.2018.8517251.

Rupasingha, R. A. H. M. and Paik, I. (2018b) 'Improving Service Recommendation by Alleviating the Sparsity with a Novel Ontology-Based Clustering', Proceedings - 2018 IEEE International Conference on Web Services, ICWS 2018 - Part of the 2018 IEEE World Congress on Services. IEEE, pp. 351–354. doi: 10.1109/ICWS.2018.00059.

Rupasingha, R. A. H. M. and Paik, I. (2019) 'Alleviating sparsity by specificity-aware ontology-based clustering for improving web service recommendation', IEEJ Transactions on Electrical and Electronic Engineering, 14(10), pp. 1507–1517. doi: 10.1002/tee.22970.

Rupasingha, R. A. H. M., Paik, I. and Kumara, B. T. G. S. (2017) 'Improving Web Service Clustering through a Novel Ontology Generation Method by Domain Specificity', Proceedings - 2017 IEEE 24th International Conference on Web Services, ICWS 2017, pp. 744–751. doi: 10.1109/ICWS.2017.134.

RUPASINGHA, R. A. H. M., PAIK, I. and KUMARA, B. T. G. S. (2018) 'Specificity-Aware Ontology Generation for Improving Web Service Clustering', IEICE Transactions on Information and Systems, E101.D(8), pp. 2035–2043. doi: 10.1587/transinf.2017EDP7395.

Shoval, P., Maidel, V. and Shapira, B. (2008) 'An Ontology- Content-based Filtering Method', 15, pp. 303–314.

Solvang, M. L. (2017) 'Video Recommendation Systems Finding a Suitable Recommendation Approach for an Application Without Sufficient Data', (August).

### Acknowledgment

This study was conducted under the Department of Computing and Information Systems, Faculty of Applied Sciences at the Sabaragamuwa University of Sri Lanka. We acknowledge all the people who were directly and indirectly help us to complete the research work successfully.

### Author Biographies



L.R.M.A.M Weerasinghe is an undergraduate student at the Sabaragamuwa University of Sri Lanka. His research interest in recommendation systems.



R.A.H.M Rupasingha received her bachelor's degree in 2013 from Sabaragamuwa University of Sri Lanka. She obtained her master's and the PhD degree in 2016 and 2019, respectively from the School of Computer Science and Engineering, the University of Aizu, Japan. Her research interests include Web service clustering, ontology learning, and recommendation systems.

## A Systematic Review and Comparative Study of Electronic Medical Record (EMR) Systems to Support Healthcare

TA Gamage<sup>1#</sup>, WNS Dabarera<sup>1</sup>, KKH Nethmini<sup>1</sup>, GAI Uwanthika<sup>1</sup>, LP Kalansooriya<sup>1</sup> and B Wijay<sup>2</sup>

<sup>1</sup> Department of Computer Science, General Sir John Kotelawala Defence University, Sri Lanka,

<sup>2</sup> Ambassador for Science Technology and Innovation for Sri Lanka, USA

# 36-se-0009@kdu.ac.lk

**Abstract:** The need for an Electronic Medical Record(EMR) system has grown exponentially with the vast increase in population, where it is strenuous to deal with patients' medical records physically. EMR grants the electronic entry, upkeep and perpetuation of medical information of patients over long periods which in turn provides quality care and safety in healthcare organizations. Nevertheless, EMRs have been a huge leap in the medical field, where hospital records are computerized for the betterment of patient care. In fact, EMRs are ought to reduce the manual work done and upgrade the efficiency in healthcare systems. This paper focuses on the significance of EMRs in healthcare organizations with the help of a review on the researches done on EMR systems and a comparison done between the EMR systems which have been implemented so far. Also through this, it is aimed to identify the insights along with the features and functionalities to be included when implementing a quality and an innovative EMR by bridging the gap in the knowledge for improving EMRs in the healthcare sector.

**Keywords:** Electronic medical record(EMR); healthcare; hospital records; computerized; patient care

### Introduction

An electronic version of patients' medical records is termed as Electronic Medical Records through which we can gather, create and store medical records of patients

electronically and with these, doctors can provide complete and accurate details about their therapeutic assessment. The development of EMR systems has resulted in many novel possibilities for patient awareness and confidentiality. For an improved deployment of the EMR system, keeping the privacy and security of information and using national and international standards are dominant prerequisites. Enhancing patient care and enlarging the efficiency of primary care practice are principal considerations of an EMR system. Actually, it is meritless to utter regarding the current healthcare systems which are managed physically with very composite and external rules. Those kinds of systems are enormous obstacles to dispatch a quality service to the users. In order to avoid such kinds of drawbacks, the EMR is very significant and to gain the benefits of EMR systems it is needed to have a system and team based attentiveness and attestation-based drugs. Also it is a durable record of patient medical data generated by so many encounters. EMRs provide considerable benefits to physicians, clinical operations and healthcare institutes(Agency for Healthcare Research and Quality). Indeed, as the use of EMR inflates, along with the depth and breadth of details they contain, the ethical use of EMR data needs building and maintaining patient confidence and acceptance in the stewardship of their particulars(Aviran, 2020). Benefits from the upheaval in medical information systems

would not be precise until and unless there is the worldwide adoption of a truly interoperable EMR in a global extent(B. Devkota and A. Devkota, 2013)

According to the third global survey on eHealth based on the reported data 2016, below are key discoveries on EMRs. A steady increment has been observed in the adoption of EMR systems and also there is a 46% global increase in EMR systems. EMR systems have been adopted over 50% by the Upper-middle and High-income countries as depicted below. Adoption rates of EMR in countries with lower-middle income are 35% whereas low-income countries adoption rate is near 15%.

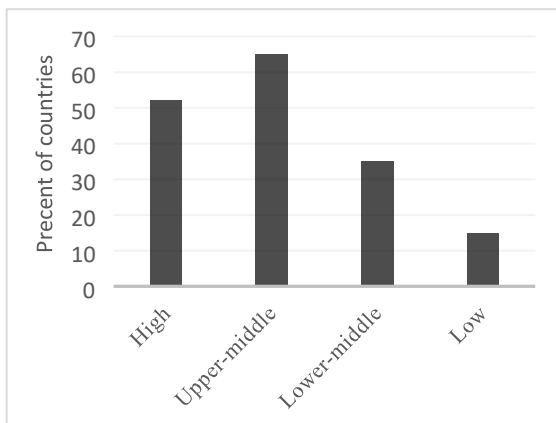

*Figure 1. Percentages of countries with a national electronic health record system classified by the World Bank Income group(Global Health Observatory (GHO) data, World Health Organization)*

Taking the above facts into consideration it is much obvious that the utilization of an EMR provides much more benefits to the healthcare sector and the main objectives of this paper are to identify the significance of the utilization EMR systems and to recognize novel and innovative features and functionalities that should be included in the implementation of an EMR through a comparison study done between the EMR systems and a literature review done on EMR systems in addition to the analysis on the evolution of EMR.

## Background

The basis for the development of the EMR systems was set out in the 1960s and 1970s. The usage of EMRs, has not only made it simple for seeking medical information of patients from anywhere the system is accessible, but also has an impact on healthcare by transforming the format of medical records which were used as paper records earlier as a tradition.

Approximately 73 hospital and clinical details were in progress by 1965. The Problem Oriented Medical Record(POMR) is one of the most outstanding attempts to upgrade the maintenance of medical records of patients which was invented by Dr.Lawrence Weed in 1968. The main objective of this was to dispense the EMR notion to provoke an electronic record that allows a third party to recognize the diagnosis on its own, and it predominantly concentrated on clinical data handling. These systems are also termed as hospital information systems. POMR is still being practiced by some medical providers where the system has mainly five facets that operate to provide the precise view of a patient's well-being and therapy requirements. The five facetes include database, complete problem list, initial planning, daily progress notes and discharge summary. However, the POMR framework is fairly harsh, and was refused by many healthcare professionals saying that the POMR is very troublesome, and an long-winded process.

And in 1972, the very first version of EMR was introduced. The Regenstrief Medical Record System(RMRS) was developed and launched by Dr.Clement McDonald. McDonald recognized the issue of the outline of the database and the diverse problems that emerge when aiming to interconnect healthcare institutes, regulations and healthcare authorities through a central medical record system. Through clinical tests, McDonald spotlighted the ways of

enhancing patient care with the use of EMRs. However, due to the high cost of the system, it prevented the usage of the system among physicians, instead of being used by healthcare institutions.

In order to keep track of patient therapeutics, various academic and research centres have implemented their own electronic medical record systems. Novel features and functionalities have become available additionally for healthcare providers and outlined to further enhance patient care, electronic systems, past medical history, housed drug dosages, side effects, allergies and drug interactions there by improving the healthcare sector. Also, it has facilitated the providers to take care of their patients with the incorporation of electronic diagnostics and treatment methods.

In the late 1970s EMRs were implemented and gradually became the Veterans Information Systems and Technology Architecture(VISTA) in the early 1990s. Implementation of EMR (by the Veterans Administration(VA)) that occurred at the same period as the Regenstrief system emerged. That system permitted the medical ordering, procedures, lab tests, diets and x-rays.

Also, some EMRs were developed with hierarchical databases with the integration of hospital billing and scheduling systems and this can be cited as a major approach in the medical field. Some clinical systems like COSTAR, PROMIS, TMR and HELP were implemented between 1971 and 1992 to enhance the developing medical care for the utilization in medical exploration.

In fact many publications that had a huge influence on the improvement and success of EMR systems were published, the book named "The Computer Based Record :An Essential Technology for Health Care" which was published in 1991 is one of them. The main idea behind this was computer based

patient records. Institute of Medicine of the US stated that by 2000, physicians' offices must have technology to enhance patient care and also gave policy recommendations of the way to reach that goal in 1991. In 1996, the Health Insurance Portability and Accountability Act(HIPAA) was established as a reaction to the vast developing electronic medical information.

In the 2000s, the EMRs were built with the inclusion of security needs that are still taken in to consideration while an EMR is implemented. EMR products include the safety precautions such as data backups, log-offs, data encryption and access control. Only 20% of office based physicians had taken on an electronic record system by 2004. Also the advent of web based technology made it possible for more providers to bring in the benefits without the need to spend much on hardware. Extending the services provided by the EMRs was done by cloud based systems to address providers' needs beyond documentations.

Research(Boricky and Kushniruk, 2012) depicts that North American healthcare organizations are in the preliminary phases of EMR adoption. In addition, it describes how EMRs create medical information more approachable to physicians and support healthcare providers with their organizational and decision making in related to healthcare. HIPAA restrictions were tightened and subjected to enforcement in 2009 with the effect of Health Information Technology for Economics and Health(HITECH) act. As a result, EMRs make security conformability easy, without allowing time and resources , the encryption and access controls with individual authentication able to make it simpler.

In chapter 18 of the book named "Handbook of Medical and Healthcare Technologies"(Kastikas,2013) discusses the impact on EMR with the rapid change in proliferation of Information and

Communication Technology (ICT), threats against the security and privacy of EMR other than the legal and ethical requirements to adhere to when addressing the scope with regard to the security of EMRs.

Furthermore, Artificial Intelligence (AI) has proven the enhancement of EMR quality care and has a great potential to make the EMR systems efficient, flexible and intelligent since complicated navigations have been a critical issue faced by many physicians with the existing systems.

### Literature Review

This section deals with the vast amount of researches that relate to the EMR systems which depict the development and evolution of EMRs and their impact on healthcare.

A research (Williams and Borren, 2008) reveals that an EMR elevates efficiency of the workflow of healthcare providers. EMR systems aid in precise medication records, clear notes and prescriptions, instantly accessible charts, decreased medical issues and development in quality care and regulations in patient well-being. This research has also exposed the fact that despite the significance of EMR systems in improving clinical care and policy in developed countries, some issues or provocations that must be overcome still exist. Those include hardware and software compatibility, practise, lack of quality assurance and outdated configuration. Another issue faced by the world associate with sustainable energy, availability and authenticated permit to electricity is crucial in healthcare evolution.

The study (Waithera et.al, 2017) has exposed the fact that the EMR systems have led the way to an elevation in the productivity of healthcare conveyance and better decision making related to healthcare. The vital barriers spotted were scarcity of funding for the adaption and manipulation of the EMR systems, computer ignorance of employees

and reduction of Information Technology (IT) personnel in the provision. The furtherance in IT has had influence in all sectors including healthcare that have assisted in alleviating barriers faced by healthcare currently. These barriers include decreasing avoidable blunders, developing communication between healthcare providers and managing the expense for the medical care. A customary drawback upheaved was system and network failure. Also some tasks were not attainable. The utilization of IT in healthcare is rapidly obtaining world demand with many personnel adopting electronic medical record management systems.

Another research was to find the effects of EMRs on citizen health. Health Information Technology is becoming more comprehensively employed, however, the industry has still not been able to reach its overall approachability. The aim is to identify whether the use of electronic medical information can improve the healthcare in the society, as well as to recognize main constraints for its adoption and the key use. As worldwide adoption of a completely interoperable EMR advances, variety of obstacles identified in this review such as standards, and resistance to alter could be alleviated. As more data becomes attainable through the EMR, relationships to consequences should emerge. Appropriate training on EMRs usage, may help with the level of intricacy among healthcare providers and their employees. Also, EMR can enhance healthcare productivity and coherence to well deliver citizen health. A plenty of healthcare information can be administered through databases by using EMRs, and this makes data simply shared between providers and organizations (Kruse et.al, 2018).

In a research (Poelgeest, 2020) qualitative study was conducted using twelve experienced medical experts of twelve

distinct Dutch hospitals with different specialisms, whose expertise within the hospitals ranges between 5 to 27 years where semi structured interviews of 90 minutes were held. Through this study, it was concluded that the interviewees consider digitalized records as a great leap forward when compared with the paper records due to its real time access.

In many countries, healthcare systems have been modified with the utilization of some form of IT, principally with reference to EMR. IT which is utilized productively, can restore old disputes in supplying healthcare services (Drak et.al, 2013). This article also discusses on the implementation of EMR in healthcare systems worldwide through SWOT analysis (Strengths, Weaknesses, Opportunities and Threats) and cluster a lesson that can be learnt with the continuation of the systems. However, some technical and non-technical challenges also must be sorted out before strong EMR systems can be converted in to realities in healthcare sector. These include problems of patient privacy and confidentiality, medical practitioner acceptance of closer inspection by management, regulatory standards for electronic medical records and cost effective justification for funding in EMR systems.

A study (Alsharo et.al, 2020) explored the attitude of healthcare experts towards adopting a Health Information System (HIS) nationally where the context of the study was done in Jordan. The discoveries of this research suggest that perceived usefulness of HIS is a significant cause of user perception towards utilizing the system. Also it was observed that at the early stages though the system might be somewhat difficult to use owing to the reason that it is newly practised, but after adapting their practices to using the system and realizing the value of the HIS, this attitude changed to positive.

The research (Hamade et.al, 2019) aimed at identifying interventions for improving EMR

practicing in primary healthcare settings using ten online databases which were searched to investigate studies conducted in primary healthcare background aimed at implementing interventions to identify the use of EMRs and promptly quantify the utilization of EMR tasks and results.

Another research (El-Yafour et.al, 2020) investigates the vast usage of EMR systems throughout the United States and the factors influencing the adoption of these systems such as intention drivers, subjective norms factors, perception drivers and perceived behavioral control drivers contributing to the research group by revealing the specific drivers of the behavior of healthcare providers. However, the limitation of this research is that it only concerns physicians but not on the other crucial actors of the healthcare organization namely, nurses, pharmacists, patients, medical administrators etc.

When the improving functionalities of the EMRs are considered, a study depicts that "Six of the twelve completing the study favored the use of the Speech Recognition (SR) for creating electronic progress notes of traditional method of entry. There was no clear perceived benefit from SR in terms of data entry time savings, quality of care, quality of documentation, or impact on clinical and administrative workflow" (Holmes, 2016).

The comparative study (Abiy et.al, 2018) focuses to fill the evidence gap by evaluating the absoluteness and trustworthiness of paper and electronic medical records and investigate the provocations of guaranteeing data standard at the Anti-Retroviral Therapy (ART) clinic at the University of Gondar Referral Hospital in Northwest Ethiopia. ART care is a long-lasting treatment, which requires precise and authentic data gathered over an extensive period of time. Poor standards of medical records have left a provocation and are

immediately connected to the quality care of healthcare sector. In order to enhance this, there is an improving tendency to implement EMRs in healthcare institutes. Nevertheless, there is miniature proof on the influence of EMR on the standard of medical information in less resource containing hospitals like in Ethiopia. The overall ART data standard was still moderately better in paper records than the EMR systems. The major reason influencing the EMR data quality was the contemporary dual documentation utilization both physically and electronically for the same patient in the healthcare institutes. It is the responsibility of hospital authorities to decide to use either the paper or the electronic system there by saving time with single documentation practice. Trainings and uninterrupted sustain for healthcare staff have been proposed to build the capability of healthcare employees on data management practices.

Another systematic review exposes that physicians may come across a series of challenges as they proceed towards EMR implementation. And also it concludes that the quality of change management plays a major part in the advancement of EMR implementation(Boonstra and Broekhuis,2019).

Also, apart from EMR systems which are implemented with the intention of maintaining patient medical information in diagnosing and prescribing medications, some systems were also researched and implemented for some fundamental procedures which are practised within healthcare organizations.

A study(Ali et.al, 2015) focused on a Blood Donation Management System(BDMS), a web application with the sole intention of the blood donation procedure, supporting a mobile application that supports patients and blood donors which is much beneficial easing the access to available blood donors.

Another study(Ruwisch et.al, 2016) aimed to conduct a content analysis of EMR adjustment for serving tobacco treatment and to arrange those modifications in a document with the use of 5A's framework(Ask, Advise, Assess, Assist, Arrange).

### Discussion

Storage and maintenance of patient records digitally for an extended period of time support in diagnosing the diseases accurately and reliably and there by preventing patients from unneeded checkups and therapeutics. And at the same time it is able to determine how patient measures up to certain essentials like blood pressure readings, vaccinations etc. Therefore, it can be stated that organizations get advantages of providing coherent and precise care for the customers through EMRs.

Initially, the physicians began with paper records, and still nowadays also it is been used. But healthcare information sharing among providers is difficult and inconsistency of health records collected from various physicians leads to errors, delays and lowered the level of health care.

*Table 1. Comparison between EMR Systems which have been used since decades*

Software	Security				Client type		Features																		
	Secure authentication and access control	Secure storage	Secure exchange	Logging mechanism	Web based	Native	Mobile	Client of Documentation	Record Management	Patient Administration	Report Generation	Scheduling	Billing	Medication Management	Accounting	Statistical Analysis	Staff Management	Order Entry	Prescribing	Laboratory Management	Medical Consulting	Community Health Management	Mobile Access	Disease Management	Electronic Data Interchange
FreeMED	✓	✗	✗	✗	✗	✗	✗	✓	✓	✓	✓	✓	✓	✓	✓	✓	✓	✓	✓	✓	✓	✓	✓	✓	✓
GNUmed	✗	✗	✗	✗	✓	✓	✓	✓	✓	✓	✓	✓	✓	✓	✓	✓	✓	✓	✓	✓	✓	✓	✓	✓	✓
GNU Health	✓	✗	✗	✗	✓	✓	✓	✓	✓	✓	✓	✓	✓	✓	✓	✓	✓	✓	✓	✓	✓	✓	✓	✓	✓
Hospital OS	✗	✗	✗	✗	✓	✓	✓	✓	✓	✓	✓	✓	✓	✓	✓	✓	✓	✓	✓	✓	✓	✓	✓	✓	✓
OpenEMR	✓	✗	✗	✓	✓	✓	✓	✓	✓	✓	✓	✓	✓	✓	✓	✓	✓	✓	✓	✓	✓	✓	✓	✓	✓
OSCAR	✓	✗	✗	✓	✓	✓	✓	✓	✓	✓	✓	✓	✓	✓	✓	✓	✓	✓	✓	✓	✓	✓	✓	✓	✓
WorldVista	✓	✗	✗	✓	✓	✓	✓	✓	✓	✓	✓	✓	✓	✓	✓	✓	✓	✓	✓	✓	✓	✓	✓	✓	✓
ZEPHS	✗	✗	✗	✓	✓	✓	✓	✓	✓	✓	✓	✓	✓	✓	✓	✓	✓	✓	✓	✓	✓	✓	✓	✓	✓
ClearHealth	✓	✗	✗	✓	✓	✓	✓	✓	✓	✓	✓	✓	✓	✓	✓	✓	✓	✓	✓	✓	✓	✓	✓	✓	✓
MediFax	✗	✗	✗	✓	✓	✓	✓	✓	✓	✓	✓	✓	✓	✓	✓	✓	✓	✓	✓	✓	✓	✓	✓	✓	✓

Software	Delivery	Support	Compliance	Specialty	Software Features																												
	Platform																																
	Cloud	On-Premise	IOS app	Android app	Multi-Office	Web app	HIPAA	ICD-10	CPT	HL7	Allergy and immunology	Cardiology	Dentistry	Family Medicine	Mental and behavioral health	Appointment management	Billing Management	Clinical workflow	Document Management	EM Coding	Insurance and claims	Patient History	Reporting and Analytics	E-prescription	Voice recognition	Scheduling	Referrals						
Allscripts	✓	✓	✓	✓	✓	✓	✓	✓	✓	✓	✓	✓	✓	✓	✓	✓	✓	✓	✓	✓	✓	✓	✓	✓	✓	✓	✓	✓	✓	✓	✓	✓	
NextGen	✓	✓	✓	✓	✓	✓	✓	✓	✓	✓	✓	✓	✓	✓	✓	✓	✓	✓	✓	✓	✓	✓	✓	✓	✓	✓	✓	✓	✓	✓	✓	✓	
Advanced Med	✓	✓	✓	✓	✓	✓	✓	✓	✓	✓	✓	✓	✓	✓	✓	✓	✓	✓	✓	✓	✓	✓	✓	✓	✓	✓	✓	✓	✓	✓	✓	✓	✓
eClinical Works	✓	✓	✓	✓	✓	✓	✓	✓	✓	✓	✓	✓	✓	✓	✓	✓	✓	✓	✓	✓	✓	✓	✓	✓	✓	✓	✓	✓	✓	✓	✓	✓	✓

Table 2. Comparison between EMR Systems in 2020

Table 1 is a comparison between 10 open source EMR systems which have been invented in the past decades and it depicts the interconnection between those EMR systems by taking the many aspects of them in to consideration where as Table 2 represents another comparison done between the latest used EMR systems in the world by 2020 and it represents a comparison between 4 EMR systems along with their features involved.

Figure 2 illustrates how office based physicians had taken on an electronic record system by 2004 to 2017 in the United States. Not like the years before the 2000s, EMRs bring benefits for more providers as it is not needed to Table 1. Comparison between EMR Systems which have been used since decades Table 2. Comparison between EMR Systems in 2020 spend more on infrastructure or maintenance, because the web based technology made it possible to expand the service that they obtained. Many office based physicians were recording medical information electronically by 2008. In 2015 it became doubled of adoption of EMRs since 2008.

Therefore, the usage of EMR systems is gradually starting to increase year by year as EMRs give the ability to make a record that chanced for a third party to verify diagnoses and treatments independently with the integration of vast functionalities and technologies present.

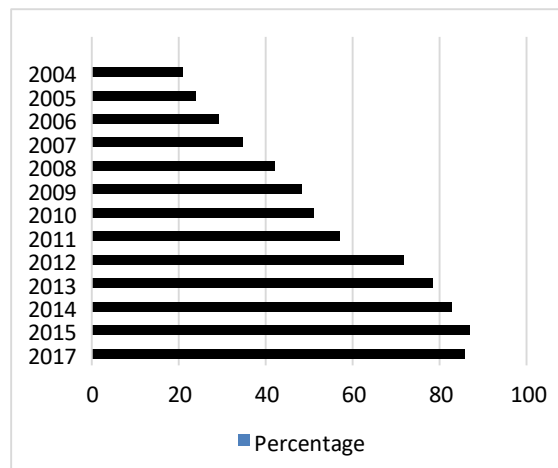

Figure 2. Percent of office based physicians using electronic medical records by the year (Morbidity and Mortality Weekly Report, 2015)

### Conclusion

On this basis, it can be concluded that a sequence of researches on EMR systems has been conducted in recent decades with the intention of researching new insights related to healthcare with the integration of IT. With the development of IT, there is a wide spread in the usage of EMR systems, thus making more straightforward to handle medical records and prescribe medicine after diagnosing the patients digitally providing more accurate and safe delivery of service. A durable record of patients' healthcare is provided through EMRs with the usage of different procedures to reduce vulnerabilities and solve problems in the modernized healthcare medical records. Through the EMR systems, it is much obvious to provide a better communication among patients and healthcare providers. Therefore, this brings out the fact that EMR provides better clinical discussions with which much of the paperwork that has been physically done has been diminished and owing to the benefits of EMR systems, patients' and physicians' satisfaction also has been improved. But, due to the fact that different EMR systems are implemented and practised in different healthcare institutions, it has been a huge prerequisite to have a better communication between these EMR



systems in order to provide a better service to the patients. Furthermore, it has been a huge need to have an EMR system with easy navigation because as the functionalities of the system expands the complexity of navigations within the system also increases. However, the developers of the EMR system and the IT system may decide the survival of the EMR system which pave the path to the vast number of EMRs with diverse functionalities and features which make those systems distinct from each other. Furthermore, it can be stated that family history, past medical history, social history, allergies, detailed symptoms, assessment, referrals, followups, lab reports and many more aspects can be used as key tools in addition to the features which have been utilized in the already implemented EMRs discussed in the paper when diagnosing a disease accurately and reliably for a better healthcare service.

### Acknowledgement

This research was greatly supported by General Sir John Koteawala Defence University and we would like to pay our gratitude to all the lecturers at the Faculty of Computing for the guidance provided throughout this research.

### References

Abiy, R., Gashu, K., Asemaw, T., Mitiku, M., Fekadie, B., Abebaw, Z., Mamuye, A., Tazebew, A., Teklu, A., Nurhussien, F., Kebede, M., Fritz, F. and Tilahun, B., 2018. A comparison of electronic records to paper records in Antiretroviral Therapy Clinic in Ethiopia: What is affecting the Quality of the Data?. *Online Journal of Public Health Informatics*, 10(2)

Scrib d. 2020. Blood Donation Management System | Microsoft Sql Server | Databases. [online] Available at: [Accessed 10 July 2020] Al Aiad, A., Alnsour, Y. and Alsharo, M., 2020. Exploring the Change of Attitude among Healthcare Professionals toward Adopting a National Health Information System: The Case of

Jordan. *International Journal of Business Information Systems*, 1(1)

Boonstra, A. and Broekhuis, M., 2010. Barriers to the acceptance of electronic medical records by physicians from systematic review to taxonomy and interventions. *BMC Health Services Research*, 10(1)

Borycki, E. and Kushniruk, A., 2012. Electronic health records and clinical trials research in the digital age. *Clinical Investigation*, 2(3), pp.227-229

Devkota, B. and Devkota, A., 2014. Electronic health records: advantages of use and barriers to adoption. *Health Renaissance*, 11(3), pp.181-184

Dc.uthsc.edu.2020.[online]Availableat:[A ccessed 10 July 2020] 0 20 40 60 80 100 2017 2015 2014 2013 2012 2011 2010 2009 2008 2007 2006 2005 2004 Percentage Hamade, N., Terry, A. and Malvankar-Mehta, M., 2019. Interventions to improve the use of EMRs in primary health care: a systematic review and meta-analysis. *BMJ Health & Care Informatics*, 26(1), p.e000023

Engineering, F. and University, F., 2020. Handbook Of Medical And Healthcare Technologies | Springerlink. [online] Link.springer.com.Availableat: [Accessed 10 July 2020]

Kim, E., Rubinstein, S., Nead, K., Wojcieszynski, A., Gabriel, P. and Warner, J., 2019. The Evolving Use of Electronic Health Records (EHR) for Research. *Seminars in Radiation Oncology*, 29(4), pp.354-361

Kruse, C., Stein, A., Thomas, H. and Kaur, H., 2018. The use of Electronic Health Records to Support Population Health: A Systematic Review of the Literature. *Journal of Medical Systems*, 42(11)

2020.[online]Availableat: [Accessed 10 July 2020] Schindler-Ruwisch, J., Abroms, L., Bernstein, S. and Heminger, C., 2016. A content analysis of electronic health record (EHR) functionality to support tobacco treatment. *Translational Behavioral Medicine*, 7(2), pp.148-156

Waithera, L., Muhia, J. and Songole, R., 2017. Impact of Electronic Medical Records on Healthcare Delivery in Kisii Teaching and Referral Hospital. *Medical & Clinical Reviews*, 03(04)

Williams, F. and Boren, S., 2008. The role of the electronic medical record (EMR) in care delivery

development in developing countries: a systematic review. *Journal of Innovation in Health Informatics*, 16(2), pp.139-145 2020.[online]Availableat:[Accessed 10 July 2020]

MMWR. Morbidity and Mortality Weekly Report, 2015. QuickStats: Percentage of Office-Based Physicians with a Basic Electronic Health Record (EHR) System,\* by State — National Electronic Health Records Survey,† United States, 2014§. 64(34), pp.963-963

Businessnewsdaily.com. 2020. The Best Electronic Medical Record (EMR) Software Of 2020 - Business News Daily. [online] Available at: [Accessed 17 July 2020]

### Author Biographies



TA Gamage Second year undergraduate at General Sir John Kotelawala Defence University. Following the BSc(Hons) Software Engineering Degree programme. Studied at Visakha Vidyalaya, Colombo.



WNS Dabarera Second year undergraduate at General Sir John Kotelawala Defence University. Following the BSc(Hons) Computer Engineering Degree programme. Studied at Holy Family Convent, Wennappuwa.



KKH Nethmini Second year undergraduate at General Sir John Kotelawala Defence University. Following the BSc (Hons) Computer Science Degree programme. Studied at Yasodara Devi Balika Vidyalaya, Gampaha.



GAI Uwanthika Received BSc(sp) in Computer Science and Technology degree from Uva Wellassa University. Currently pursuing her master's degree at University of Peradeniya. Research interests include Digital Image Processing, Bio Informatics, and Deep Learning etc. More than 3 years of

experience in teaching. Moreover, published several research papers related to this profession so far.



Dr. Pradeep Kalansooriya is the Head of the Department of Computer Science, Faculty of Computing, General Sir John Kotelawala Defence University, and a Senior Lecturer of the Faculty of Computing. This author was awarded the Doctor of Engineering of Information Science and Control Engineering by Nagaoka University of Technology, Japan. The main research interests include Human-Computer Interaction, Affective Computing, Ambient Biomedical Engineering, Hologram Technology, and Distance Learning.



B Wijay Holds the positions of Honorary Professor – Kotelawala Defence University, Ambassador for Science-Technology and Innovation of Sri Lanka, President or ProSum, Inc., a medical device innovation company in Houston, Texas- USA

## Lawyers' Work Management Through Digitization

MVT Kawya# and N Wedasinghe

*Department of Information Technology, General Sir John Kotelawala Defence University*

# tharanikawya@gmail.com

**Abstract:** With the technical renaissance, every single process has become automated by shifting from the manual ways into the digitization. This research emphasizes the digitization of business processes within a law chamber. The main issue that leads to propose an automated system for lawyers is the bulk of unorganized workloads and file cabinets. The system is to be developed with functionalities such as; maintain separate client folders depending on each clients' case category. Furthermore, the system is to embed the system with the functionalities of time reminders and alerts, chatbots, saved templates, and e-versions of the reference books. The aforesaid all the capabilities are to be maintained in cloud storage enabling always-on access through the application. But, organizing the workloads and file cabinets is not sufficient to optimize efficiency and effectiveness. It is useful to provide search queries to past similar cases and their results that have been handled. This research is to emphasize that the digitalization of the work at a lawyer's chamber will reduce the number of physical interactions and also will optimize the efficiency and effectiveness of the manual process of working patterns.

**Keywords:** Digitization, Lawyers, Case Files, Lawyers' chamber, Automation, Attorney, Advocate

### Introduction

The lawyers pay an important role in the Sri Lankan government sector in balancing the truth and justice to assure the social equilibrium. Whenever any citizen in the world is faced with an injustice, that person has the responsibility to question his or her

rights against the misbehavior or the illegal act of the other party. So, lawyers, without any colour, race, or nationality discrimination they try their optimum to do justice for them. Though they use all their efforts to win the justice from there part there is no digitalized proper way of managing their work stuff, for lawyers to work effortlessly. It is that they must waste a lot of their time and effort to file a case by filling all the accurate documents into separate files. Whenever any client intervened with a case, the respective lawyer has to open a file for that case and have to collect and then file all the information; documents; shreds of evidence; proceedings all these things manually. Moreover, if any change occurred in those documents the lawyer must find the files one by one through the file rack, to take the correct file out of from the rack, and to do each update manually. Furthermore, if a lawyer is handling many cases of a single client then the lawyer must maintain several files. So, this management of multiple files for a single client makes the lawyer's work complex and more tiresome. If the client requested an update the lawyers must go through all the files of the respective client to find which file is that the update should be done, by reading the case details. In addition to that, the manual management of the lawyer's business process retains them in the traditional era and makes everyone busy updating and keep reminding or noting down the file numbers; next court dates; status, etc.

So, this research aims to emphasize a file management system for lawyers to manage their client's works by storing their files in cloud storage enabling access to their files at

any time at any place when they are in need very simply and easily. Through this system, the clients can maintain separate files for each client and even store multiple cases of the same client.

#### A.Objective

The objective of developing this system is to embed the process of digitalization into the field of lawyers, to help lawyers to optimize their work efficiency by saving time and eliminating the extra efforts to do the same thing for times.

The new system will replace their manual work with technology upgrading their quality of work. Along with that, this system will automate the processes more efficiently and effectively than the traditional filling methods.

In this paper, section one, section two, section three, section four, section five, section six and section seven are comprised of Introduction, Literature review, Methodology, Evaluation, Conclusion, Acknowledgement, References respectively.

#### Literature Review

Though the Sri Lankan lawyers have not yet stepped into the means of using applications or any other software to manage their paperwork more efficiently using a file management system, in the technical renaissance, some foreign lawyers have touched the step of digitalization. There are many systems in the application in foreign law firms. Namely, those systems are "Cilo", "MyCase", "Filevine", "E-File Cabinet", "CaseFox", "App4Legal", "Best Case", "Pro Law", etc. ("Best Legal Case Management Software | 2020 Reviews of the Most Popular Tools & Systems," n.d.) But these software applications are not much applicable for the Sri Lankan context lawyers. Mainly because their functional requirements have targeted on billing and invoicing, expense tracking and time tracking. But for a Sri Lankan

lawyer and a client, the fee for the lawyer depend upon the lawyer's practiced patterns and the relationships they have in between the client and the lawyer. But with the proposed system the major functionality is targeted on document and case file management as in a Sri Lankan law firm the burning problem is the inefficiency and the ineffectiveness with the bulks of files loaded in narrow office rooms.

When considering each software that has mentioned above, each has its unique features. Sometimes one or multiple applications have been adopted with the common unique features. When considering the applications, "Clio", "MyCase", "Filevine", "e-FileCabinet", "CaseFox", "App4Legal", "Best Case", "Pro Law", they possess common features such as document management, time tracking, online payments, invoicing and billing, tracking of expenses in parallel to the time usage, integration of Dropbox, Microsoft office excel plugin, auditing, etc. and it has reviewed in the following, "Filevine - ABA Legal Technology Buyers Guide," n.d., "Clio vs eFileCabinet Comparison | GetApp®," n.d., "App4Legal vs Best Case vs CaseFox vs ProLaw - 2020 Feature and Pricing Comparison," n.d. But in addition to the above-mentioned features, except billing, invoicing, time and expense tracking, the proposed system is to be built with more other features such as chatbot, saved templates, Microsoft Word plugin, alert system, a link connecting the advocate and the lawyer, calendar reminders, cloud access and access to e-reference books.

Other than the above reviews and comparisons on the systems on usage many other technical experts have proposed to develop an information system for law firms. In the paper of T. du Plessis and A.S.A. du Toit has emphasized the above statement clearly, "Several studies have shown that in the most recent years' advances in the ICTs are

transforming the methods that lawyers use to access, retrieve and process information to deliver legal services to clients”(Du Plessis & Du Toit, 2005). Moreover, that paper points up that the lawyers need organized access to the information generated concerning their clients while they are active in handling the case. Not only that, but the organized arrangement of the previous notes and case information should also be easily accessible at any time since those can be useful in other cases(Du Plessis & Du Toit, 2005). According to the search results, some web applications have provided the service of file management for the lawyers and the most commonly used, popular software for managing lawyer’s work are; “MyCase”, “Clio”, “eFileCabinet”, “File vine”, “Actionstep” etc.(“Clio - ABA Legal Technology Buyers Guide,” n.d.). According to the research ideas by “West” and “Thomson”, the document management systems allow lawyers to reuse some of their products. Also, it has said that DMS (Data Management Systems) is a better way to optimize work efficiency and effectiveness (Knowledge-management systems for law firms, 2003). Not only that, but the authors, Taylor and Aschner have also emphasized that “a file management system should be more functional rather than being organizational” (Aschner, 1986). Alok Mishra, Deepti Mishra (Mishra & Mishra, 2011) further emphasized that the digitalization of the work at legal firms makes it more cost-effective, time-saving and especially adds competitive advantage among the busy and unorganized work patterns of others. In the paper, “Method and systems for performing legal services over the internet” (Classification, 2002) described a system where all the documents related to each client is stored in a cloud, where that lawyer and the related client can access their documents, review and update easily and efficiently at any time from any place they are. So, with these features nowadays Sri Lankan lawyers have played more attention

to change into the new technology. It is that according to the “Van Ooarscot” and “Irene”, the clerks and the judges who have practiced their work to be carried out with the paperwork manually have confronted with the digitalization of courts’ work. So, according to that paper, to satisfy the users of the system, the system should provide fair functionalities that will support the lawyers to improve their quality of work while optimizing time management than before(Van Oorscot, 2014). In the context of this file management, “Aschner” in 1989 has supposed a file management system with an approach to develop a generic file classification that covers broad subject areas and differentiates between file classifications based primarily on retention requirements. Also, they have emphasized that it will enable the users to add subject details to individual file folder labels to meet local retrieval requirements and will save money and easier to master than detailed schemes(Aschner, 1986). Beyond the above mentioned main objectives of file management, the lawyers face a lot of challenges during their period of working as an attorney. The lawyers have to face situations like re-filing the cases they have handled many months or years ago. Sometimes it may be not a case of much longer, but the details may be missing or unavailable or difficult to find due to the huge bulks of file cabinets placed in the chamber. Therefore, the proper storing and permanent security for the case files are important as those points may be wanted in future cases as pieces of evidence. The “Evans, Nina Price, James” in their paper they have highlighted the need for new technology to be applied in the law firms. According to them, there is more pressure in law firms and the proliferation of legal information assets. Actually, “information overload and merely identifying and managing these assets becomes a challenge to legal firms (Evans & Price, 2017). Advances in technology are provoking law firms to embrace information

management systems and technologies, such that storage capacity in the cloud allows customer, case matters and other firm information to be stored centrally and accessed from work or home with significant cost savings, device mobility enables lawyers to access digital documents in court”(Evans & Price, 2017). In the paper, “legal Files management using big data” the authors, Aarthi, Siddharth, Athreya, & Balaji Aarthi, Siddharth, Athreya, & Balaji, (2018) have paid their attention to the above-mentioned issues and they have supposed the concept of big data mining with the use of the “Hadoop” approach. According to their ideas they point out that “The technical advantages of organizing such data can be helpful not only in certain high-profile cases where a particular order or organization must be present at the most basic level, to get information that may be the turning point that is needed to win a particular case but also assist as an alibi for any vocal statements given during a particular session and also Lawyers, as well as lawmakers, will be able to successfully get facts in the argument without any Data Unavailability” (Aarthi, Siddharth, Athreya, & Balaji, 2018). According to the (Aarthi et al., 2018) as the first step, the raw materials such as case details or files containing every aspect of a particular case are collected and organized in a structured way by dividing into groups, into subdivisions based on their case types and then those files have been analyzed using the Structured Query Language and using some basic Apache spark programming. Now after the analysis unprocessed data is then stored in a cluster. The processes of analyzing data are recorded step by step in a separate database called metadata. This data can be used for back trend analysis and also can be used as backup data in case of data loss. Along with the collection of the raw data, storing, organizing and updating the security of the data is also essential as each data is a “confidential set of information of one

another about their life matters”. Furthermore, the tacit knowledge of lawyers should be recorded so it will ease the work of lawyers in reusing the points in the future precedents of the future cases or may need in their daily cause of work. It is that “Experienced lawyers create forms, which include comprehensive annotations and practical comments that serve as models for the type of documents that are required repeatedly in the firm's daily practice” (Du Plessis & Du Toit, 2005). So, it is clear that every document and form is an essential factor for a lawyer. Therefore, those data should be recorded methodically to reduce the stress with their busy working patterns. The above points thoroughly highlight the importance of having organized and easy access for the documents for lawyers. But the easy access should not create any security breaches and doubts about the confidentiality of the client’s personal details and as well as of the case details. As emphasized in the paper by (Scheffer, 2017), “the file is not just a distracting medium, but a constitutive participant in legal discourse and it gives a voice to the client in the legal discourse”. Therefore, the priority should be given to the security of the files as well. It is as mentioned by Du Plessis & Du Toit, that in the survey conducted in African law firms, “the main concerns lawyers might hold in terms of systems revealed a considerable concern regarding information security and confidentiality, computer viruses resulting in information corruption and content authenticity” (Du Plessis & Du Toit, 2005). The researchers, Zhang, Diao, & Wen, (2008) have stated means of embedding security for the legal files and have proposed a system based on document watermark, cryptology and access control. According to the theories that have been used by “Zhang”, “The watermarks are embedded by the first author of the file. All the files cannot be read or write until they are embedded with the watermark. So, this will assure that only the

authorized users can read or write the files. And then secondly users are classed into different secure levels. Users with different security levels have different rights to operate files. As the third level of security, the symmetric key algorithm is used to encrypt the file that is embedded with the first watermark. This can prevent unauthorized users read the file. The public key algorithm is used to provide a pair of keys. The keys are used to encrypt or decrypt files. The Kang, Chen, & Zhan, (2012) has highlighted that file management as a key principle that leads towards a standard way of management. As stated in the paper, "system is a small database management one and help to achieve the following; Accurate and timely collect, process and store; help managers solve daily routines and relieve the work intensity; improve working efficiency and management levels, to create a principled, institutionalized, standardized and scientific management; enhance management capabilities; assist to draw up plans, allocate resources practically, and promote the quality and effectiveness at the best level; transfer from decentralized management to systematic one and integrated basic files". Here the (Kang et al., 2012) has implemented the system using technologies such as; Visual Studio 2005 development platform, C # Programming Language, Structured Query Language (SQL) Server 2005 database management system. Furthermore, the existing software vendors such as "MyCase", "Clio", "eFileCabinet" etc. provides many numbers of functionalities. As emphasized in the ("Filevine - ABA Legal Technology Buyers Guide," n.d.) the key features are; include bill and expense tracking, a settlement calculator, deadline management, record management and advanced reporting and more other common functionalities like; track important deadlines, manage cases and documents and bill and collect from clients; manage tasks for the day, week or month and track billable time directly; scheduling

purposes, etc. Further according to the proposed system by the Mishra, Alok, and Mishra, Deepti there are modules within a single system named as, File management; Asset management; Workflow and document management; Support services management, etc. Through all those modules though they have divided into differently named modules, they all function to ease the work of lawyers. According to their concept, that system consists of main functionalities such as; "printing of letters, notices and reports, automated creation and updating of case records, track the availability of documents, sending various alerts like email, a fax can be provided to the users with deadlines and schedules, etc." (Mishra & Mishra, 2011). So as mentioned above systems have been proposed to develop and some are to be developed with the functionalities that have been identified as the solutions for the existing business problems. As technology is ubiquitous people are more vigilant about every single new thing that comes into the trend. Due to that vigilance customers are more demanding for the quality, effectiveness, and efficiency for whatever the service or the business they engage in. As mentioned by (Evans & Price, 2017), "Clients are often ahead of lawyers in implementing new technologies, and they also have improved access to the legal information that is readily available on the Internet.

The review and comparison of the features of the similar applications existing are depicted in the following Table 1

Clients of law firms are therefore becoming increasingly sophisticated and demanding". So, it is clear that the time has arrived to shift from the traditional way of acting into the modern way technology.

Table 1. Review on similar application’s features

Main Features	Similar Applications	Proposed System
	Clio, App4Legal, Best Case, CaseFox MyCase, Filevine, e-FileCabinet.	
Document management	✓	✓
Time tracking	✓	✗
Contract & conflict management	✓	✗
Invoicing & billing expenses	✓	✗
Cloud access	✓	✓
Calendars and event notifications	✓	✓
Email management	✓	✓
Case notes and client managemnet	✓	✓
SMS alerts	✗	✓
Saved templates	✗	✓
E-versions of the reference books	✗	✓
Chatbot communication with paralegal	✗	✓

### Methodology

The research was carried under two phases. Phase one was to analyze the “perception of the Sri Lankan lawyers regarding the development of a file management system and the current issues they undergo when maintaining bulks of files and the urging requirements”. The second phase of the research was to analyze the systems that have implemented by early developers and the works of literature were reviewed.

In the development process of the system, the agile methodology is used as it is flexible and allows for changes and the following steps were followed.

### A. Requirement Gathering

As the first step, the requirements for the system were gathered by interviewing a sample of lawyers. In addition to that, a google form was shared among the lawyers to measure the applicability of digitizing the lawyers’ work under the Sri Lankan context.

### B. Analysis

Secondly, the gathered information was analyzed to cross-check the lawyers’ preferences about the automation of the manual process and their likelihood to shift into a digitalized system. As per the analysis results, as a whole, their main idea is that conventional file management makes them inefficient and more tiresome. Also, they point out that the manual method of file management wastes a lot of their time in searching for the files through each rack and then going through each page. Furthermore, it has analyzed that most of them are busy with the existing systems and it is not convenient for them. Also, an analysis of the literature was conducted to get knowledge about the existing systems.

The final overview according to the age groups of the Sri Lankan Lawyers’ analysis results is shown in the following Figure 1.

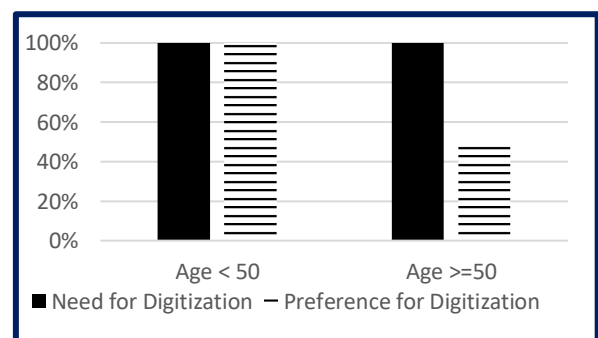

Figure 21. Results from the interviews and survey

### Design

As the third step, the design of the system was sketched to match the client’s requirements. As to implement the design of the system, use case diagrams and high-level architecture were sketched. The architecture



was designed to depict how clients interact with the servers and each client to collaborate online. According to the designed architecture, the clients and the lawyers can connect via a network, and lawyers can maintain their files using cloud access. The application was designed to give access from any device that works with any operating system. Some of the screenshots captured from the proposed system design are

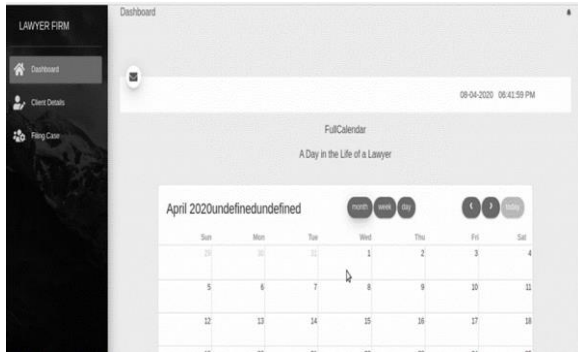

depicted below

Figure 2. Lawyer's Dashboard

Figure 3. Add Clients

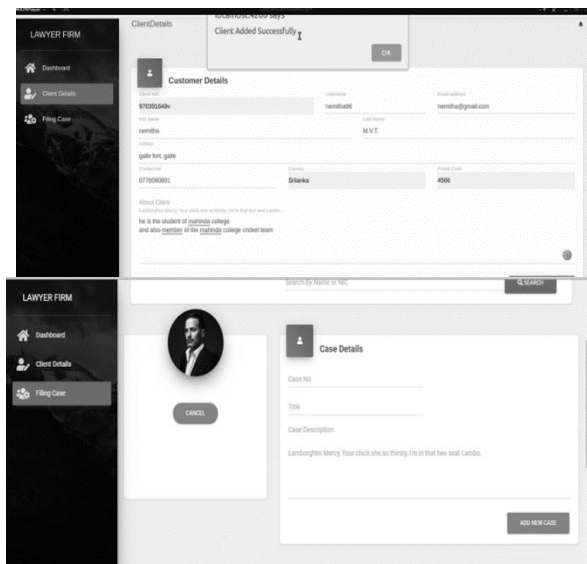

Figure 4. Add Case

## Evaluation

Many ideas have been proposed with different technologies to implement a secure file management system into the conventional way of managing legal files. The proposed system under this research paper is to be developed with the functionalities;

files, client and case management, Calendar management, SMS generation, email management, saved templates, and access to eversions of the reference books. Furthermore, to enable the concept of “any time at any place” the cloud technology has been implemented with a mixture of service-oriented architecture for the business process. So, developing the system the cloud technologies such as “Software as a service” can be articulated.

## Conclusion

With the rapidly changing technology, every single process has transformed into digitization. But the file bulks of lawyers are still the same. In the Sri Lankan context though many industries, many departments have joined with the active process of shifting from manual paperwork to the digital era, still, the law chambers haven't raised their ideas to reengineer their work processes. As discussed in the above, the problem within the law firm is mainly the workload and lack of tidiness and organization of those work stuff and the lack of proper management systems to handle their clients' details. Therefore, this research is to digitalize the management of file work in an advanced method by allowing the work efficiency both for the lawyer and the client. The idea is focused on optimizing the file management and also time management through online collaborations.

So here, in this paper, its focus is on developing an application that better suits the working requirements of a Sri Lankan lawyer working under the Sri Lankan context.

### A. Deliverables

The system provides the facility of file management for the lawyers. At first, each lawyer must create their personal accounts by registering with the application. Then the lawyers can create a separate folder for each of their clients and separate files depending

on the case of each client they are handling. The system is to develop with an alert system to remind the lawyer and the witness party about their next court day and then the system auto-generates a notification to the respective clients. The systems also have the feature of embedded templates and the e-versions of the reference books that lawyers

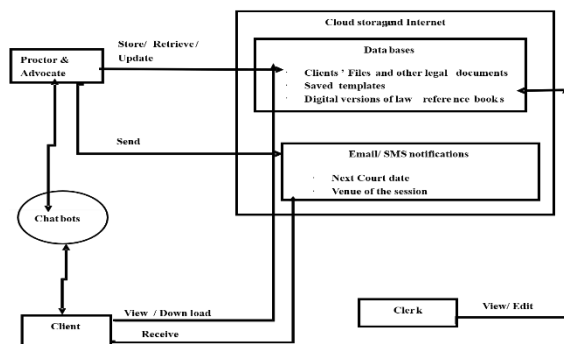

need while sketching the cases

Figure 5. Experimental Design

## References

Aarhi, S., Siddharth, S., Athreya, V., & Balaji, P. (2018). LEGAL FILES MANAGEMENT SYSTEM USING BIG DATA. 2018 3rd International Conference on Communication and Electronics Systems (ICCES), (Icces), 979–983.

App4Legal vs Best Case vs CaseFox vs ProLaw - 2020 Feature and Pricing Comparison. (n.d.). Retrieved April 5, 2020, from <https://www.capterra.com/legal-case-management-software/compare/146976-180363-121682-35611/App4Legal-vs-Best-Case-Bankruptcy-vs-CaseFox-vs-ProLaw>.

Aschner, K. (1986). Files management in the paperless office. *Journal of Information Systems Management*, 3(4), 78–81. <https://doi.org/10.1080/07399018608965279>.

Best Legal Case Management Software | 2020 Reviews of the Most Popular Tools & Systems. (n.d.). Retrieved April 5, 2020, from <https://www.capterra.com/Legal-case-management-software/>.

Classification, P. (2002). (12) Patent Application Publication (10) Pub. No.: US 2002/0019741 A1.

Clio - ABA Legal Technology Buyers Guide. (n.d.) Retrieved October 11, 2019, from [http://](http://buyersguide.americanbar.org/sites/clio/3092/Document+Management)

[buyersguide.americanbar.org/sites/clio/3092/Document+Management](http://buyersguide.americanbar.org/sites/clio/3092/Document+Management).

[americanbar.org/sites/clio/3092/Document+Management](http://buyersguide.americanbar.org/sites/clio/3092/Document+Management).

Clio vs eFileCabinet Comparison | GetApp®. (n.d.). Retrieved April 6, 2020, from- <https://www.getapp.com/finance-accounting-software/a/cilo/compare/efilecabinet/>.

Du Plessis, T., & Du Toit, A. S. A. (2005). Survey of information and knowledge management in South African law firms. *SA Journal of Information Management*, 7(1). <https://doi.org/10.4102/sajim.v7i1.252E>

vans, N., & Price, J. (2017). Managing information in law firms : changes and challenges.

Filevine - ABA Legal Technology Buyers Guide. (n.d.). Retrieved October 11, 2019, from <https://buyersguide.americanbar.org/sites/filevine/8930/Document+Management>

Kang, D., Chen, J., & Zhan, J. (2012). Design of University Teachers' s ) files Management System. (1), 298–300. <https://doi.org/10.1109/CIS.2012.73>

Knowledge-management systems for law firms. (2003). Retrieved from <https://patents.google.com/patent/US8126818B2/en>.

Mishra, A., & Mishra, D. (2011). A Legal Business Information System: Implementation Process Context. 8(2), 45–59.

Scheffer, T. (2017). File work, legal care, and professional habitus an ethnographic reflection on different styles of advocacy.(July).<https://doi.org/10.1080/09695950701323005>

Van Oorschot, I. (2014). Seeing the case clearly: File-work, material mediation, and visualizing practices in a Dutch criminal court. *Symbolic Interaction*, 37(4), 439–457. <https://doi.org/10.1002/SYMB.126>

Zhang, H., Diao, J., & Wen, Q. (2008). Secure Files Management System in Intranet. 306–311. <https://doi.org/10.1109/ICICSE.2008.100>

## Acknowledgment

The authors would like to acknowledge the General Sir John Kotelawala Defence University for the enormous guidance given.

### Author Biographies



M V Tharani Kawya is a student from the Faculty of Computing, General Sir John Kotelawala Defence University, followed BSc (Hons) in Information Systems. Her research interests are in the field of Management Information Systems.



Nirosha Wedasinghe graduated from London Metropolitan university-UK, and she has completed her Masters in CSU Australia. Currently, she is reading her Ph.D. in the KDU Postgraduate Faculty. Her research interests are in the field of Digital accessibility and Management Information Systems. She has published, reviewed and supervised many research nationally and internationally.

## An Analysis of Applying Software Development Methodologies in Military Software Development

LM Wijethungaarachchi# and SPIU Dayarathna

*Centre for Research and Development, Ministry of Defence, Sri Lanka*

# lahiru@crd.lk

**Abstract:** The precise selection of the most suitable software development methodology is crucial to any small or enterprise level software application. Specifically, considering the development of military software applications which ranges from training, management, planning and operational scenarios, the proper usage of software development methodologies could significantly affect the decisions made regarding national security. Researches carried out in this particular domain is very limited and, in an era, where military software applications are growing and making a heavy impact on the military strategies, it is vital to understand the importance of selecting and adhering to the best methodology and the need to follow the software engineering guidelines. The main objective of the research is to study the features of existing software development methodologies and evaluate the application of such in various military scenarios. The research will be carried out primarily using qualitative methods supported by quantitative methods where necessary. The result of the research will provide a clear understanding to military software developers in planning, developing and implementing future software projects.

**Keywords:** Software Methodologies, Software Engineering, Defense Applications, Mission Critical Systems

### Introduction

Software engineering is an ever-evolving and rapidly growing industry in modern world. From workflow management to Complex process automation and expert systems, the

application of Software Engineering aspects plays a vital role. Software design and development has been revolutionizing the way businesses are carried out than any other industry. At the base of this Engineering paradigm lies the software development methodologies. Which are a set of frameworks that are defined for planning, executing, and managing the process of system development. Even the industry has been around for only few decades, there are many development methodologies that are in practice proving that the application of these methodologies impacts a vast range of subjects and multiple domains.

The military has always been a frontrunner in technology, and has always been equipped with modern equipment's ranging from hardware-based weaponry to defensive establishments. But the modern threat environments demand militaries to shift their focus from hardware to software (Hagen, 2013). The software development practices and methodologies are not explicitly developed keeping military requirements at its core. Hence, there are multiple issues that persists when development of a military software is undertaken by a team of software developers. A number of factors are in play such as; rapidly changing threat environments, cyber warfare, management of personnel and authorization. A considerable conflict with the standard software development methodologies can be observed in terms of time factor and human resources due to the confidential nature and mission criticalness. The research aims to

evaluate the aptness of utilizing available development methodologies and to provide a summary recommendation on the aspects to be considered when choosing a development methodology for future military software projects.

### Literature Review

The literature review conducts a detailed review of some of the well-known software development methodologies that are being practiced such as; Waterfall, Spiral, RAD (Rapid Application Development), Agile and DevOps. The review aims to present their origins and critically discuss the advantages and disadvantages of each methodology. The objective of the review is to give a better understanding of the usability of methodologies when it is applied to a military scenario. A. Waterfall Methodology Considered by many as the forerunner of Software Development Lifecycle (SDLC) methodologies. Sometimes referred to as the linear sequential model, this methodology states that fundamental processes such as specification, development, and evolution should be considered as different phases when developing a software. Those phases are considered as Requirements specification, Software design, Implementation, Testing, etc. (Sommerville, 2016) The model was first introduced by Royce W.W (1970) as a method to manage the development of large-scale software projects. The waterfall model is a classic example of a plan driven model where the activities must be properly planned and scheduled before execution. The stages of the waterfall model reflects the following fundamental development activities. (Sommerville, 2016).

- i. Requirements analysis and definition.
- ii. System and Software design.
- iii. Implementation and unit testing.
- iv. Integration and system testing.

v. Operation and maintenance.

Theoretically, a phase needs to be completed completely in order for the next phase to be started or needs to be approved (Sommerville, 2016). But the practical scenario demands a certain diversion from this theory. The phases need to be overlapped. And provide feedback to one another. (Figure 1).

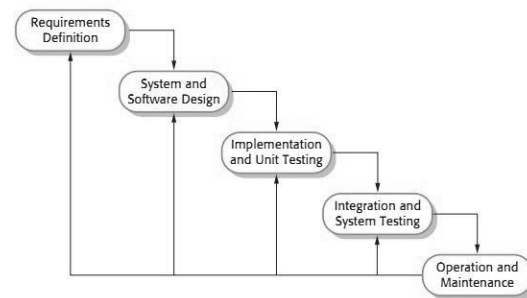

Figure 1: Waterfall Model (Source: Sommerville, 2016)

The Waterfall model has been introduced nearly 4 decades ago but still widely used and popular among software engineering community. Mainly due to the following notable features.

- i. Simplicity.
- ii. Ease of management due to each phase having clearly defined deliverables and reviews.
- iii. Phases are completed one at a time. Hence managing resources is easy.
- iv. Highly effective in projects that has clearly understood requirements.
- v. Demands structured organization.
- vi. Early design changes are permitted.
- vii. Ideal for milestone-based development projects.

However, due to the cost of iterations that could occur due to multiple feedback and review processes, in practice, it is recommended to lock or freeze certain phases upon reaching a milestone (Sommerville, 2016) and continues with the rest of the development process. This may

result in badly structured or the resulting system fails validation from the user. When the software is put into use in the final phase. The failures and omissions occurred in the early phases are discovered. Errors emerge and user's demand new or altered functionalities. Hence for the system to remain in use, it must return to the initial phases to iterate the process. In addition to that, following disadvantages also persists with the waterfall model.

- i. Lack of a working system until the final phase.
- ii. High risk and uncertainty.
- iii. Difficulty in applying to complex and dynamic scenarios.
- iv. Difficult to measure progress before the completion of each phase.
- v. Cannot adapt to rapidly changing requirements.
- vi. Minimal/None user feedback during the development processes.

Even though many criticisms exist about the usage of traditional waterfall method in modern software projects, it is worthy to note that Waterfall methodology has paved way for many successive SDLC processes models.

## B. Spiral Methodology

Another member of the SDLC family, Spiral methodology is a risk-driven process framework introduced by Boehm (1986). The process is diagrammatically represented as a spiral with multiple loops. Each loop represents a phase of the software development process such as, feasibility study is represented by initial loop, Requirement analysis and design is represented by subsequent loops etc. The number of loops can be varied from one project to another. The spiral model reflects changes as a result of project risk and is therefore extremely supports risk handling.

In diagrammatic representation, each loop is divided into four sectors. (Sommerville, 2016) (Figure 2)

- i. Objective setting.
- ii. Risk assessment and reduction.
- iii. Development and validation.
- iv. Planning.

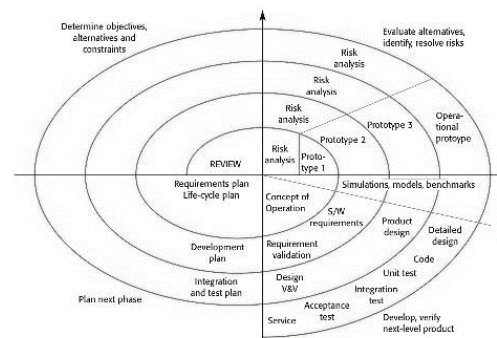

Figure 2: Boehm's spiral model (Source: Sommerville, 2016)

As stated above, due to its nature of explicit recognition of risk, the model allows adding instances of the software product when it is available or a considerably agreed prototype is developed. That guarantees that there is minimal conflict with previous designs or builds. In contrast to the Waterfall method, Spiral model also accommodates early user involvement in the development process. The advantages of spiral model are not limited to above as it also includes;

- i. Proper risk evaluation.
- ii. Flexible requirements are permitted.
- iii. Ability to add new features and changes systematically.
- iv. Space for customer feedback.
- v. A working software is produced early in the process.
- vi. Easy cost estimation.
- vii. Faster development.

On the contrary, Spiral model demands strict management capabilities and there is a risk of spirals running into infinite loop.

Furthermore, following disadvantages persists with this methodology.

- i. Complex management.
- ii. Cannot forecast the exact end of project.
- iii. Not suitable for small projects.
- iv. Excessive documentation.
- v. Expensive.
- vi. Difficulty in time management.

C. RAD (Rapid Application Development)  
Rapid Application Development is a methodology built providing a heavy emphasis on rapid development of prototypes for testing functions and features. The term was popularized by James Martin (1991) in a book of the same name. The RAD model came into existence as a solution to the problems observed in traditional Waterfall method. One of the main drawbacks that exist in the Waterfall method is the inability to accommodate changes in core functionalities once the software development is underway. By emphasizing on prototyping iterations RAD allows the accurate measurement of progress in real time. The RAD model could be broken down into multiple phases. But according to James Martin (1991) it can be divided into 4 distinct phases.(Figure 3).

- i. Requirements planning phase.
- ii. User design phase.
- iii. Construction phase.
- iv. Cutover phase.

It seems that RAD model can be utilized for all projects effectively, Nevertheless, while it can be applied to quick projects handled by small teams it's not effective in many other scenarios. A few advantages of RAD model are;

- i. Ability to change requirements at any time
- ii. Prioritize on customer feedback.
- iii. Quick reviews.

- iv. Reduced development time.
- v. Early system integration.

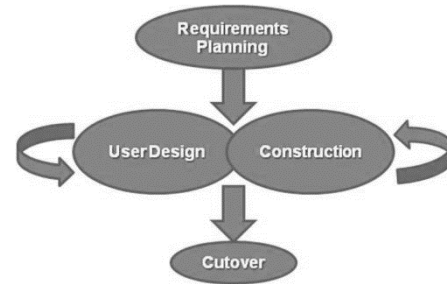

Figure 3 - RAD model (Source: Wikipedia)

While there are many benefits that implies RAD is a perfect model. Following disadvantages also persists with the model.

- i. Requires the development and designer teams to be highly skilled.
- ii. Constant user involvement.
- iii. Can only be applied effectively in modular systems.
- iv. More complex to manage.
- v. Suitable only for projects requiring shorter development time.

The RAD presents strong benefits to a team that is familiar with the agile philosophy and highly skilled in the development realm and also has a relatively small project to roll out with clients willing to take part throughout the process. Nevertheless, it is not recommended to be used in projects that does not fulfill above criteria.

#### D. Agile Methodology

Many of the software development methodologies in 80s and 90s were highly plan-driven methods. It was believed that better software could only be achieved by careful and formalized planning, analysis, design and testing (Figure 4). However, these methods produced an unnecessary overhead when applied to small and medium sized businesses, Hence, a number of software developers proposed new "agile methods" for development (Sommerville, 2016) which

allowed developers to focus on software development rather than its design. Agile methodology is itself a host or a family to another set of processes based on agile principles. Which are;

- i. Customer involvement.
- ii. Incremental delivery.
- iii. People not processes.
- iv. Embrace change.
- v. Maintain simplicity.

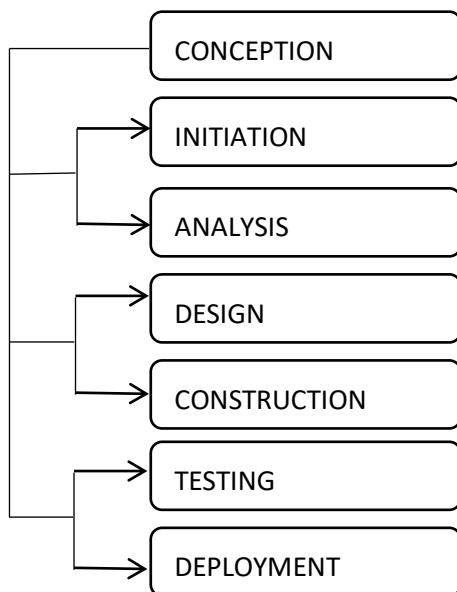

Figure 4 - Agile methodology (Source: Author Developed)

Agility in its namesake defines the flexibility and quick adaptation to changing environments. Various agile methods are;

- i. Scrum.
- ii. Crystal Methodologies.
- iii. DSDM (Dynamic Software Development Method).
- iv. Feature Driven Development (FDD).
- v. Lean Software Development.
- vi. Extreme Programming (XP).

While the objective of this research is not to discuss deeply on this subset of

methodologies, there are number of advantages in following the agile methodologies. Which are;

- i. Emphasis on modern techniques.
- ii. High adaptability.
- iii. Continuous customer feedback.
- iv. Iterative development.

Even though agile methodologies are considered the perfect and suitable approach to modern software development, there are considerable disadvantages associated with it.

- i. Difficulty to add changes within iteration.
- ii. Minimal emphasis on documentation.
- iii. Relies on real-time communication with users.

While agile is seemingly similar to the RAD methodology. It is widely recommended that for certain large-scale software projects application of agile could be problematic. Hence, it is recommended to adapt to a hybrid approach when using agile methodologies.

E. DevOps DevOps is a rather new and evolving software development methodology that focuses on communication, integration and collaboration among the IT practitioners to enable rapid deployment of software. DevOps promotes collaboration between development and operations teams (Figure 5). It is not just a development methodology but also an organizational culture. The combination of the development and operations teams promotes continuous integration, continuous deployment, automated testing and transparency in code repositories. (Ismail, 2018).



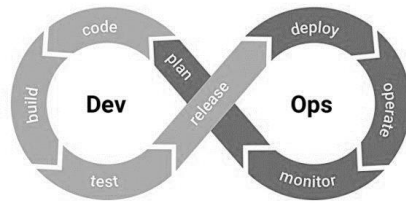

Figure 5 - DevOps methodology

The distinctive advantages of DevOps are;

- i. Improved time of product release.
- ii. Low failure rate.
- iii. Minimize disruption.
- iv. Improved customer satisfaction by continuous deployment.
- v. Employee productivity and efficiency.

Even with all above benefits, major drawbacks of the methodology are;

- i. Certain customers are not expecting continuous updates.
- ii. Some companies have strict policies to ensure that a product goes through extensive testing before it is used in operation.
- iii. If development and operational departments use different environments, unseen errors could occur.

### Research Methodology

The research is conducted through a hybrid approach mainly based on qualitative research methodologies with which are slightly combined with quantitative methodologies. The research domain is fairly new, hence the authors had to consult developers and software engineers who are both serving in the military and civil industry. This was done primarily through focus groups and a questionnaire was used. Informal interviews were conducted in order to further clarify their insights. The discussions were focused on the constraints experienced by software developers when developing military systems in contrast to developing civilian systems. The questionnaire was distributed among

serving software engineers/developers within armed services in the format of a google form and shared using email and social networks. Microsoft excel and Google charts were utilized to visualize the acquired data.

The questionnaire took a straight forward approach to find the proficiency of each developer about the different software development methodologies and to obtain their perspective on the constraints that are in place when developing military software. The authors defined the mostly used software development methodologies and the general constraints after focus groups sessions. Then individual anonymous responses were obtained to further clarify the findings. These findings were used as the basis for demarcating the constraints and software types which will be argued against the different methodologies in the discussion. Data from 30 respondents were used in the analysis.

### Results and Discussion

This section summarized the research findings and results.

The developers were questioned on their proficiency in the software development methodologies that were outlined in the literature review. Which are;

- i. Waterfall method
- ii. Spiral Method
- iii. RAD
- iv. Agile methods
- v. DevOps

The findings are represented as follows; (Figure 6)

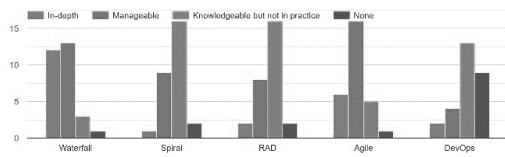

Figure 6– Proficiency on development methodologies (Source: Author) Developed

It is observed that the most of the developers were highly proficient in early SDLC methods such as Waterfall but lacks a certain amount of knowledge in modern, versatile and flexible methodologies. This could be mainly due to lack of exposure to the evolving technologies.

Throughout the group discussions the developers were asked to group the software applications that they have developed into categories as follows.

- i. Workflow automation
- ii. Operational support
- iii. Decision support
- iv. Training

Developers were asked to provide their efforts in adapting the SE methodologies for the above applications from the initial stage (Figure 7).

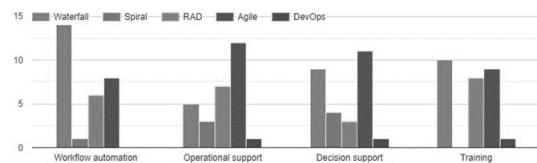

Figure 7 Adaptation of SE methodologies (Source: Author) Developed

It is notable that the majority of developers opted to use Waterfall method as the preferred methodology. Mainly due to the high level of proficiency they have gained in applying the same and the ability to reuse certain components as many workflow automation applications proved to follow a similar approach. This was also done as means of time management.

Even though the standard methodologies were applied in the initial stage of system development, the developers responded that it was problematic to adhere to the methodology throughout the development process as represented below (Scale of 1-5, 1 being low adherence and 5 being strict adherence) (Figure 8).

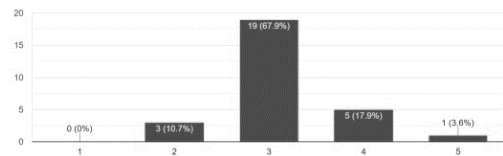

Figure 8: Adherence to methodology (Source: Author) Developed

The researches then asked respondents to provide insight on the constraints that led to the deviation from selected methodology. The defined limitations and difficulties were;

- i. Time frame – The time given for the end product to be delivered
- ii. Mission criticalness – The accuracy and completeness of the delivered product/components
- iii. Unclear requirement identification – The Avenue to adapt to constant requirement changes
- iv. Complexity of processes – Constant user interaction to verify and validate processes
- v. Human resources – Avenue to assign developer teams

It is observable that the difficulty in specifying clear requirements and the limited timeframe has played a major role in forcing the developers to deviate from the standard methodology. And few state that the nature of systems and the importance of those in strategic operations is a considerable limitation. (Figure 9)

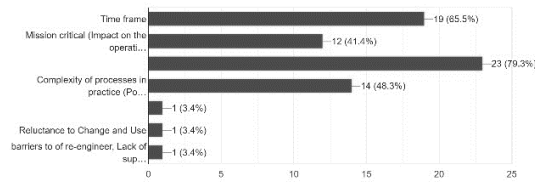

Figure 9- Constraints affecting military software (Source: Author Developed)

With the above result the authors also inquired about the factors that they define as important in developing military software. The factors were also agreed upon the focus group session and then used to obtain individual responses. The defined factors are as follows; (Figure 10)

- i. Compatibility with existing systems
- ii. Usability and reliability
- iii. Application of State-of-the-art technology
- iv. Software security
- v. Good practices in coding (Standards)

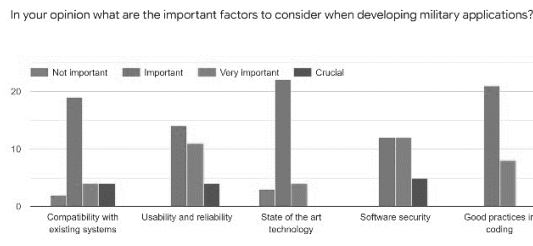

Figure 10 - Factors considered in developing military software Source: Author Developed

Many developers agree that while compatibility with existing systems is important it is equally or more important to consider the new techniques and security of the software is a crucial factor. This is a highly notable point to be discussed further when evaluating the suitability of methodologies as it narrows down to certain features offered by different methodologies.

With the above results the authors moved onto evaluate the deviation of applications from each methodology against the major factors found in the questionnaire responses. In order to effectively demonstrate the

evaluation a sample project was selected to represent each of the application categories. (Table 1) (Generic names are being used Figure 10 - Factors considered in developing military software (Source: Author Developed) Figure 9- Constraints affecting military software (Source: Author Developed) Figure 8: Adherence to methodology (Source: Author Developed) to denote certain applications due to the confidentiality).

Table 1: Sample software projects developed by military (Source: Author developed)

Application name	Type of application	Category
Postman	Document management	Workflow automation
Banker	Financial management	Operational support
Warlord	Command and Control	Decision support
Red baron	Simulator	Training

Each methodology is evaluated based on their emphasis on the constraints presented on each of the above systems (figure). The developers were asked to point out the factors which deviate from the standard if the application had followed each methodology. (X) Denotes the factor forces deviation from the methodology where (Y) denotes the factor is applicable within the methodology.

#### A. Postman application

The objective of this application is to automate the manual process of forwarding official documents to relevant parties and keeping track of each and every document including their status. Following limitations and allowances were identified by the developers. (Table 2).

- i. Higher time frame
- ii. Low Mission criticalness

- iii. Unclear requirements / End user awareness
- iv. Low complexity of processes / Low user interaction
- v. Low human resources

Table 2: Deviating factors – postman application (Source: Author developed)

Emphasis	Methodology				
	Waterfall	Spiral	RAD	Agile	DevOps
Higher Time frame	Y	X	X	X	X
Low Mission criticalness	Y	Y	Y	Y	Y
Unclear requirements / End user awareness	X	Y	X	Y	Y
Low Complexity of processes / Low User interaction	Y	Y	X	X	Y
Low Human resources	X	X	X	Y	Y

### B. Banker application

The objective of this application is to maintain a complete and systematic record of all transactions within the organization. Following are the limitations and constraints identified by the developers. (Table 3)

- i. Less time frame
- ii. Low Mission criticalness
- iii. Dynamic requirements
- iv. Complex processes / High user interaction
- v. Low human resources

Table 3: Deviating factors – Banker application (Source: Author developed)

Emphasis	Methodology				
	Waterfall	Spiral	RAD	Agile	DevOps
Less Time frame	X	X	Y	Y	Y
Low Mission criticalness	Y	Y	Y	Y	Y
Dynamic requirements	X	Y	Y	Y	Y
Complex process / High user interaction	X	Y	Y	Y	Y
Low Human resources	Y	X	X	Y	X

### C. Warlord application

The objective of this application is to automate the tasks which are carried out in a battlefield coordination centre. Following are the limitations and constraints faced by the developers. (Table 4)

- i. Less time frame
- ii. High Mission criticalness
- iii. Dynamic requirements
- iv. High complexity of processes / High user interaction
- v. Low human resources

Table 4: Deviating factors – Warlord application (Source: Author developed)

Emphasis	Methodology				
	Waterfall	Spiral	RAD	Agile	DevOps
Less Time frame	X	Y	Y	Y	Y
High Mission criticalness	Y	Y	X	X	Y
Dynamic requirements	X	Y	Y	Y	Y

High Complexity of processes/ High User interaction	X	Y	Y	Y	X
Low Human resources	Y	X	X	Y	X

#### D. Red baron application

The objective of this application is to create a virtual reality application that simulates the training environment experienced by a soldier. Following are the limitations and constraints faced by the developers (Table 5).

- i. Higher time frame
- ii. High Mission criticalness
- iii. Clear requirements / End user awareness
- iv. High complexity of processes / High user interaction
- v. Low human resources

*Table 5: Deviating factors – Red baron application  
(Source: Author developed)*

Emphasis	Methodology				
	Waterfall	Spiral	RAD	Agile	DevOps
Higher Time frame	Y	X	X	X	X
High Mission criticalness	Y	Y	X	X	Y
Clear requirements / End user awareness	Y	Y	Y	Y	Y
High Complexity of processes/ High User interaction	X	Y	Y	Y	X
Low Human resources	Y	X	X	Y	X

The above results and finding indicate that while some phases of a methodology has

avored the development process, certain phases have failed to provide the expected outcome. The common deviations that can be derived from the above scenarios are;

- i. Demand of faster delivery.
- ii. Critical components have to be delivered faster while ensuring the accuracy.
- iii. End users not having a of proper understanding of the necessity of the software application resulting in vague requirements
- iv. Limited Developer resources

Above problems indicate that the root cause of the deviation of methodologies mainly lies in the planning processes. The traditional software planning process should be altered/ modified to effectively allow this transition of information and to suit the demand posed by the military environment.

#### Conclusion

The above results and evaluations clearly indicate that due to the dynamic and variable nature in the scenarios it is problematic to apply a single software development methodology to the required systems. It is clearly visible that multiple components or phases practiced in different methodologies are required in the development of a single system.

It is best to merge in to existing military planning processes in order to produce a productive and usable plan by every stakeholder. Authors present the following recommendation as a guideline for software project planning for future military software projects. The fundamental of military planning includes the following 7 questions. These questions have tested and field proven in effective military planning. (UK Army doctrine, 2010)

- i. What is the situation and how does it affect me?
- ii. What have I been told to do and why?

- iii. What effects do I need to achieve and what direction must I give to develop my plan?
- iv. Where can I best accomplish each action or effect?
- v. What resources do I need to accomplish each action or effect?
- vi. When and where do the actions take place in relation to each other?
- vii. What control measures do I need to impose?

The software planning commonly involves following phases. (Kate Eby, 2018)

- i. Scope statement
- ii. Work breakdown schedule
- iii. Milestones
- iv. Gantt Chart
- v. Communication Plan
- vi. Risk Management Plan

The phases of the software planning process effectively answer the aforementioned questions. Hence, in order for the software project to be focused on the military aspects from the foundation level, the following information transfer outline is recommended to be used in military software planning.

- i. Situation } System
- ii. What is the requirement? } scope
- iii. What needs to be achieved? - WBS
- iv. When and where to achieve? } Milestones/
- v. Resources available } Time plan
- vi. Who does what and when? – Com plan
- vii. Control measures –Risk management/Agreements

The above outline enables the complete appreciation of military requirements and resources and transfers them into the software project planning domain. The ability to provide information in a more

familiar format allows the stakeholder to be more descriptive and forces the same to do own analysis before agreeing on the software application. The information is then transferred on to the software specific criteria where they can be analyzed to select the best possible methodology. While it cannot be ensured that this planning method will be effective in civilian industry, it is recommended to apply these military fundamentals in civilian software development projects as most modern technologies has gained advantage from military practices.

### References

- Boehm B.W(1986) A spiral model of software development and enhancement
- Hagen C. (2013) Effective Approaches for Delivering Affordable Military Software <http://www.defencesynergia.co.uk/>. 2010. Army doctrine operation. [ONLINE] Available at: <http://www.defencesynergia.co.uk/wpcontent/uploads/2015/05/Army-Doctrinre-Operations-Dec2010.pdf>. [Accessed 7 September 2020].
- Ismail K.(2018) Agile vs DevOps: What's the Difference?. Available at: <https://www.cmswire.com/informationmanagement/agile-vs-devops-whats-the-difference/#:~:text=%E2%80%9CDevOps%20is%20a%20methodology%20that,Product%20Manager%2C%20Raleigh%2C%20NC>
- Martin J (1992) Rapid Application Development. PrenticeHall,Englewood Cliffs
- McGroddy J.C.(1999) Realizing the Potential of C4I
- Royce W.W(1970) Managing the development of large software systems smartsheet. 2018. Demystifying the 5 Phases of Project Management. [ONLINE] Available at: <https://www.smartsheet.com/blog/demystifying-5-phases-project-management>. [Accessed 7 September 2020].
- Sommerville I.(2016) Software Engineering.9th ed. Pearson education inc.

### **Author Biographies**

Lahiru Maduranga Wijethungaarachchi is a graduate in Bachelor of Engineering in Software Engineering from London Metropolitan University. He is serving as a commissioned officer in Sri Lanka Army with nearly 10 years of experience in planning, designing and developing software systems for the Defense services.

Ishara Udeni Dayarathna holds a higher national diploma in computer science from Infortec International and currently reading for her Bachelor of Engineering Degree in Software Engineering. She is serving as a commissioned officer in Sri Lanka Army with over 07 years of experience in developing software systems for the Defense services

## Web-Based Workload Maintain System for Midwives in Sri Lanka

DWGML Dissanayake, DU Vidanagama and N Wedasinghe

*Faculty of Computing, General Sir John Kotelawala Defence University, Ratmalana, Sri Lanka*

#themanojemail@gmail.com

**Abstract:** Public health has always been an information-intensive field. Public Health Midwives (PHM) is the 'front line' health care provider responsible for the provision of maternal and child health and family planning services at the community level in Sri Lanka. Considered several recent researches and studies have revealed these midwives have faces undue burden due to maintain number of routine documents manually and without having proper system. those registers and records and in turn, the quality of their services has been badly affected. Therefore, introducing a web-based system for midwives through a simplified solution for easy documentation, data management in online will opportunity to involve in more field activities. Furthermore, it is useful in midwives to notify daily tasks, monitoring and evaluation of the field activities for themselves. Meantime it leads to notify to mothers about their clinics, vaccinations and activities by messages mothers from eligibility registration to whole pregnancy, prenatal, childbirth and postpartum period. By considered rural families provide this message service to any mobile phone with Sinhala, Tamil and English languages without facing difficulty. Moreover, the facility of storing information and access system with any devices when their visits without referring large documentation make the system more user friendly. In a subsequent of studies, all the midwives gave positive comments indicating that they were happy with the developing system and that they would like to continue using it to enhance their service. The system

seems to be a practical solution for the daily activities of midwives in Sri Lanka.

**Key Words:** Midwife, Information management, E-Health, Health care, Maternal health

### Introduction

Public Health Midwives have been an important part of the primary healthcare system in Sri Lanka. A midwife is a health professional trained to support and care for a woman during pregnancy, prenatal, childbirth, postpartum period to family planning. By evolved into professional cadre, playing a role in many aspects other than services immensely valued in whole settings where health resources are scarce. Midwives should provide a comprehensive service to all the eligible families in her area or areas. Midwives will usually check infant's health, growth and assist advise by giving information's and appointments to meet medical and she should be responsible to keep their records and reports as well as special attention during field visits and clinic work. When appointed midwife to a specific area, she should be beginning from start to identify eligible families under that. after considering their details and health status they should be categorized and register as an eligible family. Then midwife needs to inform consulting about the aim of making a child simultaneously.in addition to that if an eligible family woman gets pregnant, start the process of registering a pregnant mother and following her up until delivery.in here arises issues when registering pregnant mothers coming from the external area.



From the beginning of pregnancy, the midwife must inform their clinics, vaccinations, home visiting, programs, and consulting programs everyone and individually. By without receiving scheduled information, formally mothers missed their essential requirements like vaccinations. After that midwives need to process of caring for postpartum mothers and educating the mother on child care.in childcare activities required to maintain child development record and follow it to care for an infant's individual. by the same time need home visits and provide nutritional supplements according to their requirements. and care at least still 5 years under her guidance by user studies and researches confirm that the current workflows of midwives to support pregnant and newborn baby care with lack efficiency by missing their care from daily duty roster. This documentation puts a heavy workload on midwives. These kinds of things realized if they have proper information system to maintain their daily activities properly. By the busy schedule of both midwives and mothers face different problems and midwives also prefer self-help support medium if they are delivered via a familiar medium, such as a web-based system are almost accessible to them using this web-based system, midwives can manage and maintain their maternal health care and workload throughout the day for a long time. Finally, buy using this web-based system computerized all main manual registration and reports can access midwives by selecting their area in online. specially want to mention any no other system currently developed for maintaining daily workload of midwives in Sri Lanka. Consider developed features and specification of this system will be able to add more features as further development.

## Background and Motivation

The web-based system is soft tools for connecting users to Internet services that are frequently accessed using personal computers and smart devices. Web technologies have made life easier and it serves the users in different aspects and it is obvious that specifically maintain systems. as an example, for that this web-based midwife workload maintain the system can be taken. As the main role of the health care service of midwives requires modern technology to manage and maintain their workload. Web-based systems can find everywhere and for one purpose uses different way and most of them are useless. Everyone focusses on the business section but not for these hidden social roles to do their service maintaining valuable time.

Most of the web-based services are complex and need simple everything from the user interface to an outcome. Since introducing cloud computing and real-time technology makes a big influence on information technology. Special sections like health care technology are very effective for access information effectively with saving time. In maternal period is dealing with two lives specially during pregnancy or shortly after childbirth. If they missing any care provided by midwives, they become o trouble. By considering all facts midwives need to work without stress to given clear health care to midwives. For their workload management. this kind of web-based system given stress released and it also helps every mother without language complexity extending rural to urban areas for making good communication using current digital technology in Sri Lanka.

## Literature Review

### A. Problem

By conducting an interview, researches, questionnaires, and case studies from midwives in the sample local area Thalatuoya, Kandy, Sri Lanka and confirm that the current workload of midwives in lack efficiency with faced many problems and issues from the registering eligible families to deliver an infant. When registering an eligible family from a related area, they must provide a unique number to identify records to carry out the whole process until becoming 5 years child.

Basically, register permanent mothers and temporary mothers separately and consider any mother coming from another area. In addition to that eligible family, register number must repeat in the whole process by connecting number taken from pregnant mother's register as well. Another hand due to busy schedule of midwives and mothers miss their clinics they must go to once a week or once a month. When considering home visiting, sometimes they don't know the exact day that visit and also pregnant mothers and new mothers don't have proper knowledge about babies behaviours, physical changes, natural cycles, etc. for that it's better to inform that by scheduling some message or notification in brief to mother before a visit.

Additionally, both parties must get the idea of clinical details, vaccinations, consulting programs and other childcare details with schedules. Currently send information by verbally and its more chance to forget. By this web-based system overcome that problem by sending message or notification to mother. In here rural peoples not having smartphone or cannot download applications to deal with this notify system. For those issues, midwives can send messages by selected mothers for the simplest mobile phones as well. Specially

rural peoples use simple mobile phones and for better understand use Sinhala, Tamil, and English languages.

The web-based system was designed according to the requirements of the midwives. The interfaces were initially developed in English but will be converted to Sinhalese and Tamil in the future. All this system carried out by Sri Lankan midwives made possible by choosing a "web-based" approach to the smart mobile devices to any computers where only requirement of an Internet browser like Firefox, Chrome, etc. By this system manage all information in a real-time database can access from anywhere with anytime with improved latest security techniques with data and information structures. Specially here provide secure message and notification service even can view from normal mobile phones used by mothers in rural areas to easy communicate with midwives.

### B. Existing systems and features

In Sri Lanka, there is one web-based system for collecting information for national statistics electronically by The Reproductive Health Management Information System (eRHMIS). This is the main source of data for national health indicators in maternal and child health, family planning, adolescence, and women's health. This system was only done part of the collection by nearly 25 data collection formats. But this system does not provide options involving midwives with their daily workload. In here taken the counts from whole reports and it can visualize data as charts, graphs, reports for connecting with different purposes.

### C. Previous Researches

There was a research "Electronic Patient Records in Sri Lankan Hospitals" by Dr Denham Pole. In here discussed current healthcare system and requirements of computerizing hospital records in the

country. A project sponsored by the Austrian/Swiss Red Cross recently carried out in the Eastern Province has, however, been successful in computerizing the medical records of over 20 government hospitals. As a highlight of that research-based almost entirely on handwritten paper records there is additional work in filing and retrieving information into computerize. And many of the weaknesses of the healthcare system with a lack of information that is stored somewhere and but is not available where it is needed.

There was another research Ubiquitous support for midwives to leverage daily activities present preliminary outcomes concerning the design of a support system for midwives in the Netherlands to carry out daily activities. And emphasis most obvious barrier is the lack of an integrated IT system to provide daily care to pregnant women. Based on the findings we propose some solutions that may help midwives to perform their daily tasks more efficiently. A key aspect of improving maternal health is to make use of the role of skilled health professionals, specifically midwives. In this research build, a mobile application intends to conduct a long-term user test to understand how midwives and pregnant women use the application. Midwives will use the mobile app when they need to visit a patient. The app for midwife is connected to the local software used in the midwifery centre to provide antenatal care.

By considering study about the role of Information Technology on the quality of maternity care in the midwifery centers in the Netherlands published research that Supporting Improved Maternity Care by Midwives Design Opportunities and Lessons Learned this also The objective was to understand the current situation, challenges and design opportunities that could help to provide improved healthcare system to care

mothers. By this system mainly focus on lack of IT training for the midwives, lack of integrity between different software systems used in the midwifery centers and hospitals and attitude of the pregnant mothers based on our findings we provide some recommendations and design implications to support improved care provided by the midwives.

The comprehensive literature review by a book Women and Birth, the popularity of pregnancy-related apps could indicate a shift towards patient empowerment within maternity care provision. The traditional model of 'shared maternity care' needs to accommodate electronic devices into its functioning. Reliance on healthcare professionals and midwives may be the availability of interactive and personalized information delivered via a smartphone and record data in Medical officer of health (MOH) centers to access and provide services.

According to research Workload of primary-care midwives conducted by T.A.Wiegers Netherlands institute for health services research, objectives that to assess the actual workload of primary-care midwives in the Netherlands and calculate active hours can service provides by midwives and make scheduling program for them to conducts their activities. Here proposed a system midwife can make their schedules and generate reports to do works etc.

Researchers have highlighted the importance of healthcare professionals' involvement in the conceptualization of smartphone-based interventions "Midwife in low resource environments challenges and opportunities in maternal and reproductive health service provision" presents that how Midview's services distribute via smart devices and mobile phone self-monitoring program to prompt mothers to report their

emotional state several times throughout the day request care by midwives.

The requirement of Guidelines Nursing Midwifery Workforce Management is discussed by World Health Organization Regional Office for South-East Asia New Delhi emphasis the managing duties of midwives in rural area guidance with contacting through application and support health care in a regional context. And manage them according to successful health system defeat difficulties. Specially present conceptual framework for the foundation of management.

In the research “Web-Based Appointment System using Short Message Service Technology” conducted by Muhammad Helmy Abd Wahab the hardware and software requirement, and integrate to provides manual operation platform, which can manage the information resource and short messages to satisfy the rural areas education purpose users requirements. Advanced ADO.NET technology is used for database management. here focus on send message to a group of peoples through the web-based system and using SMS gateway.

By research presented by Ibukun Ogunbekun is discussed the experiences of nurse/midwives with a simple management information system in the private sector are reported facilities in Nigeria. special attention should be given to strengthening the ability of health workers to record and collate data satisfactorily. Here present web-based system to manage their data for national their statistics reports.

In case of midwives management system in New Zealand, Dallas Knight of the University of Otago presented important practically applicable system by research paper “Midwives and Technology: The Case from New Zealand” mainly by this research focused on how New Zealand midwives currently use technology in their practice,

and its implications – both for midwives as well as health consumers and health organizations. It also discusses where midwives need to develop in their use of technology to meet the needs of the women and families they work with and provide evidence-based midwifery care.

General Circular No:01-26/2006 Office of Director-general of Health Services, Ministry of Health present Duty list of the Field Public Health Midwife, mentions requirements of Administrative, General Activities, Antenatal care, Intra natal care and Care of the Infant and Children and related needs.

Maternal Care Package a guide To Field Healthcare Workers book from Family Health Bureau 2011 published by Family Health Bureau, Ministry of Health Sri Lanka. This book emphasizes that requirement of development of maternal care services in Sri Lanka by considering past raised problems and issues. in addition to that discuss the inventions and maternal care models in Sri Lanka. And proposed Maternal care Model for domiciliary and clinic care shows the requirement of an administrative system for midwife care.

## **Methodology**

### **A. Requirement analysis**

Beginning of this system the researcher met his project supervisors and had a face to face interview with them about this system and how to gather requirements for this project. In the interview able to present my project idea and ask questions and get guidelines and opinions about how to develop this project. As a beginning choose central province and met local area Public Health Midwife of Medical Officer of Health (MOH) center in Thalatuoya, Kandy, Sri Lanka with mainly focus sample village Pinnagolla. Then interviewed separately midwives by explaining the project and ask for basic requirements and problems faced using their

current manual system. During the interviews and observations, the researcher could be able to ask questions from responsible persons and referred to available sources and the related process can develop as a web-based system.

The questionnaires, questions regarding their attitudes towards how the current process going on and problems difficulties facing as a written medium.

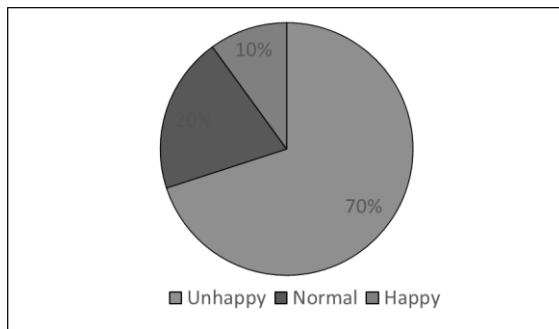

Figure 1: Questionnaire results pie chart

The needs analysis was done using a questionnaire which obtained opinions from 10 midwives in the selected MOH area who were directly involved. This chart shows they are unhappy in the current manual system. Several informal interviews conducted with midwives were useful in formulating the questionnaire. The needs analysis clearly showed that midwives spent most of their time on managing health records which might negatively affect their delivery of mother care. As it is based almost entirely on handwritten paper records there is additional work in filing and retrieving information, in copying and summarizing it and in transmitting it from one office to another. Furthermore, they need some system work online can use from anywhere they visit without carrying their whole documents. By considering their feedbacks and requests come up with a solution using available information technology.

### Design and Implementation

The system was designed according to the requirements of the users. As the main part

of the system usually, design and develop some interface that user will use. The main conception design was drawn using UML diagrams and Sketchup using Adobe XD. Specially instead develop mobile application development system as responsive web design. After that, it was shown to the midwives and the project supervisors, who provide comments, which are used to reanalyse, and redesign with affording with some features. This will process continues in a cycle until the expected results will come.

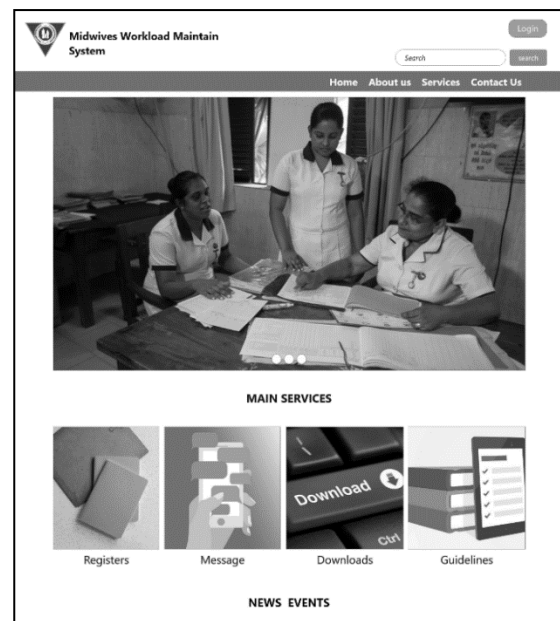

Figure 2: The main interface of the system

The goal is to provide a system with overall functionality. In the development process mainly use HTML, JavaScript, CSS, Bootstrap, Visual Studio Code and Php for interface designing and arrange connections among them. MySQL use as the main database of the system. Also, use cloud hosting service for hosting and SMS gateway API for establishing communication.

**A. Fundamental modules and usage**

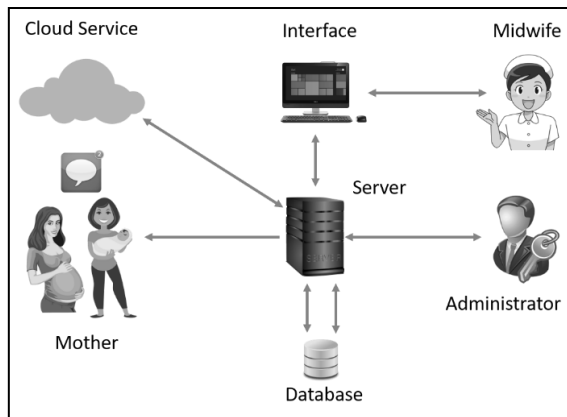

Figure 3: Basic System Design

Midwives can use this system from their MOH center computers and their smartphones. Those two types of roles in system login as an administrator or midwife the administrator (there is an officer under area) must sign into the system. By the username and password system detect user role enter as an administrator or a midwife. the administrator can create accounts for midwives, assign areas and send midwife's username and password through an email. An administrator can view whole families and areas under the main MOD area. also, besides, update and delete areas of midwives and manage when shifting midwives' different areas. Mainly administrator can upgrade system downloadable forms, kinds of stuff and maintain system correctly.

The midwife can log in into the system by already provided usernames and password. Then midwife can view dashboard consist of areas under her. And display their daily schedule like visits, vaccinations, report updating notifications etc. furthermore meetings and other activities also display on their interface. In this overview shows all the records and related details under area/areas of midwife such as Eligible families register, Pregnant mothers record, Birth and immunization record Child Development Record and family planning record. Then midwife can check or do any required changes or updates and maintain their

workload easily. After that midwives can search any records and send messages about clinics, vaccinations consulting programs and other activities as per requirements.

**B. The Overall System Architecture**

The Architectural design defines the overall structure of the system and forms a solution before moving on to the detail design or the low-level design which includes the design of specific components details. The overall system architectural design for the proposed system is as follows.

Figure 4: Overall System Architecture

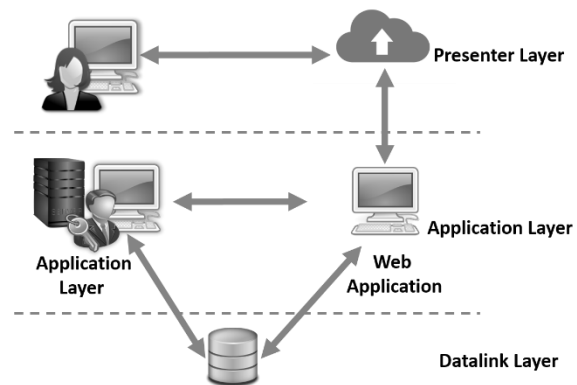

**Evaluation**

This research aims to design and develop web-based workload maintain a system for midwives in Sri Lanka. During the short period since testing the web-based system has given satisfactory results, and this has encouraged all the participants. And it is possible to generate several routine reports and returns sent to the regional and central levels from the periphery. Public health data that obtained by this system can be utilized at different levels of public healthcare administration as it is possible to transfer data readily into the main existing system electronic Reproductive Health Management Information System (eRHMS), regional and central levels.

A major feature in the system was the cost of implementation. When we took cloud service and SMS gateway API need some payment for providing services. When discussed with

family health bureau this can be easy with attached with their system. However, when long term benefits are considered, it would be a good investment to improve preventive healthcare.

The web-based workload maintain system for midwives in Sri Lanka still under developing by testing, monitoring and evaluating progress. Because of that cannot coming through a conclusion about this system. Proper monitoring and evaluation are essential for the improvement and continuity of system. Therefore, when the system was in operation the behaviour of the system and the users were monitored closely. At the same time regular discussions were conducted with users and they were provided with questionnaires to obtain their feedback and suggestions. Changes were applied to the system, depending on the responses. In other words, this study was conducted as action design research and the iteration method was used to develop the system as the project proceeded. This system was testing among selected group of midwives in a remote area of Medical Officer of Health (MOH) in Thalatuoya, Kandy district in Sri Lanka. Currently necessary training given use of laptops and progress of the project will be evaluated on regular basis. The preliminary responses obtained so far are very satisfactory.

### Discussion

While developing countries have problems, computerization can transform many of these problems into opportunities. By this system careful to avoid cost and complexity. The system used a local area network using a separate server in a safe place but connected to site via the Internet. specially this project is mainly focusing on the midwives and pregnant and post-pregnant mothers who have busy schedules and who need technological solutions to keep in touch with health care. There is no necessity to spend

any cost to use this web-based system. And having such a web-based system will provide an easy environment to the user and it will also self-direct the user to figure out all the flow of solving maternal care and self-workload of midwives. However, public health information is still managed using a manual system which was introduced a long time ago. This is not very efficient, and the manual system is time-consuming. Therefore, introducing a web-based online workload maintenance system to manage public health information has become a necessity.

The purpose of this study is to develop a web application which provides midwives through a simplified solution for easy daily workload maintenance and documentation while providing the opportunity to involve in more field activities. Besides, it facilitates instant access to health information of the community served by them. Furthermore, it is useful in monitoring and evaluation of the field activities of midwives by the supervisors and themselves. They thought that their daily work had become easier. This is presumably one of the main reasons for the high level of acceptance. Besides, midwives believed that the system was user-friendly and easy to understand. Thus, the system is a practical solution to enhance the field activities of midwives in Sri Lanka. However, further work needs to be done to study the long-term benefits. The knowledge gained from this study would be useful for future e-Health implementations in the public health sector of Sri Lanka.

### References

- Pole, D. (2010) 'Electronic Patient Records in Sri Lankan Hospitals', Sri Lanka Journal of Bio-Medical Informatics, 1(1), p. 43. doi: 10.4038/sljbmi.v1i1.1466.
- Mahmud, A. Al and Keyson, D. V. (2013b) 'Ubiquitous support for midwives to leverage daily activities', UbiComp 2013 Adjunct - Adjunct

Publication of the 2013 ACM Conference on Ubiquitous Computing, pp. 251–254. doi: 10.1145/2494091.2494171.

Mahmud, A. Al and Keyson, D. V. (2013a) 'Supporting improved maternity care by midwives: Design opportunities and lessons learned', Lecture Notes in Computer Science (including subseries Lecture Notes in Artificial Intelligence and Lecture Notes in Bioinformatics), 8120 LNCS(PART 4), pp. 635–642. Doi: 10.1007/978-3-642-40498-6\_55.

Jefford, E., Fahy, K. and Sundin, D. (2010) 'A review of the literature: Midwifery decision-making and birth', Women and Birth. Australian College of Midwives, 23(4), pp. 127–134. doi: 10.1016/j.wombi.2010.02.001.

Wiegers, T. A. (2007) 'Workload of primary-care midwives', Midwifery, 23(4), pp. 425–432. doi: 10.1016/j.midw.2006.06.007.

Maria Speciale, A. (2016) 'Midwifery in low resource environments. Challenges and opportunities in maternal and reproductive health service provision', p. 179.

World Health Organization (2003) 'Guidelines nursing and midwifery workforce management', SEARO Technical Publication, 27(February), pp. 1–17.

Helmy, M. et al. (2009) 'Web-Based Appointment System using Short Message Service Technology: Usability Aspect', pp. 534–539.

Ogunbekun, I. (1999) 'A management information system for nurse/midwives', Bulletin of the World Health Organization, 77(2), pp. 186–189.

Dallas Knight, Midwives and Technology: The Case from New Zealand, The, T. et al. (2010) 'Volume 5 / Issue 3-4 / 2010 - Features', 5(3).

Ministry of Health, Revised duty list of the Field Public Health Midwife. General Circular No:01-26/2006 Office of Director-general of Health Services, 'PHM Duty list.pdf' (no date).

Ministry of Health Sri Lanka, 'Maternal Care Package a guide To Field Healthcare Workers book'\_1, Family Health Bureau 2011, published by Family Health Bureau, Lanka.

## Acknowledgement

I would like to express my great appreciation to research supervisor Mrs DU Vidanagama for her valuable and constructive suggestions during the planning and development of this research. Her willingness to give her time so generously is very much appreciated. I would also like to thank Mrs N Wedasinghe for her advice and guidance that helped me to make this possible. I would also like to thank the staff of the Department of Information Technology, Faculty of Computing at KDU, for their valuable and precious time, which is generously and highly admired.

## Authors Biography



I am Officer cadet DWGML Dissanayake, Intake 34, undergraduate Faculty of Computing, Department of Information Technology at General Sir John Kotelawala Defence University. This research based on my final year project focused on health service in Sri Lanka. I am introducing a solution for the main problems involved in midwives, utilizing my knowledge that learned based on information technology to enhance the public health field services will improve the health service of Sri Lanka.



DU Vidanagama is a Senior Lecturer in Faculty of Computing, KDU. She graduated from University of Kelaniya in the field of Statistics and Computer Science. She completed her Masters degree in Management and Information Technology in University of Kelaniya. Her research interests include Multi-agent technology, data analytics and ontologies.





N Wedasinghe graduated from London Metropolitan university-UK, and she has completed her Masters in CSU Australia. Currently, she is reading her PhD in the KDU Postgraduate Faculty. Her research interests are in the field of Digital Accessibility and Management Information Systems. She has published, reviewed and supervised many research nationally and internationally.

## A Review of Blockchain Consensus Mechanisms: State of the Art and Performance Measures

Thanushya Thanujan<sup>#</sup>, R. A. C. P. Rajapakse, and Dilani Wickramaarachchi

*Department of Industrial Management, Faculty of Science, University of Kelaniya, Sri Lanka.*

<sup>#</sup>thanushyal@esn.ac.lk

**Abstract:** Blockchain is an emerging digital technology for creating decentralized systems which disrupts the digital world with its complex and robust architecture. It has a range of application domains; from cryptocurrencies to decentralized software applications which are commonly known as DApps. The consensus mechanism is the core of Blockchain technology. Reaching a common agreement among the nodes of a decentralized distributed network is a vital but challenging process in consensus mechanisms. Consensus mechanism enables adding a new block to the blockchain making it transparent, trustworthy and immutable. This paper presents a systematic review of existing mainstream consensus mechanisms to highlight their strengths, impulsions and limitations, and the evolution of consensus mechanisms. On the basis of their canonical properties, each consensus mechanism is having its own performance characteristics. The performance of a consensus mechanism is determined in various criteria such as throughput, mining power, energy consumption, fault tolerance, and more. However, there is no fixed common scale yet to measure the performance. At present a particular consensus mechanism is adopted by an application domain purely based on subjective criteria including trial and error. Therefore selecting the most appropriate consensus mechanism in a particular application domain requires a systematic set of guidelines to be developed. By exploring the existing literature on various consensus mechanisms and their performance

characteristics, this paper facilitates the researchers to identify the most appropriate consensus mechanism for a given application domain.

**Key Words:** blockchain, consensus mechanisms, decentralized applications, DApps.

### Introduction

The blockchain technology has developed substantially since its first notable application in 2008 which is widely known as bitcoin (Nakamoto, 2009). After invention of Bitcoin the evolution of blockchain could be divided into three main phases.

Phase one (2008 - 2013) describes the transactions of bitcoins, phase two (2013-2015) the smart contracts implemented on Ethereum(Buterin,2014) platform and, phase three (Since 2015) the development of Decentralized Applications using smart contracts which are known as DApps (Cai et al., 2018). As these applications grow with complexity there is a growing demand to attain agreement between distributed network nodes in order to make the corresponding blockchain transparent, trustworthy and immutable. Therefore consensus mechanisms are considered as one of the most vital elements in blockchain based systems.

In literature numerous consensus mechanisms have been proposed such as Proof of Work(PoW), Delayed Proof-of-Work(DPoW), Prime Number Proof of Work (Prime Number PoW), Proof of Stake (PoS),

Delegated Proof of Stake (DPoS), Leased Proof of Stake (LPoS), Proof of Stake Velocity (PoSV), Proof of Burn (PoB), Proof of Elapsed Time (PoET), Practical Byzantine Fault Tolerance(PBFT), Delegated Byzantine Fault Tolerance(DBFT), Federated Byzantine Agreement(FBA), Raft and a few more. Among them Proof of Work (PoW) ultimately has become the widely-used consensus mechanism in these days, mainly since it has been used in the bitcoin system. The core objective of all consensus mechanisms are same but in terms of implementation and performance characteristics, there are quite a lot of differences.

Apparently, meticulous security and performance analysis of most of the consensus protocols are still not published in top venues. However, the challenge of choosing the most appropriate consensus mechanism has surged in the Decentralized Applications (DApps) era of the blockchain technology. Moreover, since research on the consensus mechanisms is still not very much matured, clear guidance for the selection of an appropriate consensus mechanism has not been made available. Determining and analysing the potentiality of the mainstream consensus mechanisms will help the researchers to select the most appropriate consensus mechanism for their Decentralized Applications (DApps).

In this research work, a background study of the blockchain technology was conducted with special attention to various consensus mechanisms. With the aforementioned objective in mind, prevailing mainstream consensus mechanisms were analysed in terms of their strengths and weaknesses in different performance attributes as a systematic review. Accordingly, information has been reorganized to guide selecting a problem specific, consensus mechanism based on the expected outcome.

The rest of the paper is organized as follows. In the section- II, a background study is presented with the evolution of blockchain technology. A review of existing literature on consensus mechanisms is presented in section III, followed by a discussion in section IV on the similar work published already with comparisons of existing consensus mechanisms and the outcome of this study is presented. Finally, section V discusses the result and limitations of this study and section VI concluding the remarks.

## **Background Study**

The blockchain architecture has been evolving over the past couple of decades in terms of application and performance characteristics. Particularly with the futuristic conceptualization of DApps, the architecture of blockchain has drastically changed and the role of the underlying consensus mechanism has become highly variant but important. Hence, it is important to understand the evolution of the blockchain architecture prior to any discussion on the role of consensus mechanisms.

### **A. Evolution of Blockchain Technology**

1) Blockchain 1.0 (Bitcoin): Bitcoin is considered as the first decentralized digital cryptocurrency and it was the first application of blockchain technology. Apart from conventional currencies and other digital currencies, bitcoin is distinguishable based on some key features (CoinDesk, 2020) such as, decentralization of transactions (transactions maintained by peer to peer network), limited supply (total number of bitcoin limited to 21 million), pseudonymity (transactions are secured with public/private key addresses instead of personal identity) and immutability (validated transactions cannot be revoked). Central to the bitcoin system was a consensus mechanism called Proof of Work (PoW), which was the core technology used to ensure the transparency, immutability and

security of transactions being recorded in a chain of blocks. The Proof of Work (PoW) consensus mechanism generates and validates a new immutable block to the existing chain of blocks by solving a complex puzzle.

2) Blockchain 2.0 (Ethereum): Ethereum is an open source decentralized blockchain based platform proposed by Vitalik Buterin in 2013. His white paper (Buterin,2014) - "A Next Generation Smart Contract & Decentralized Applications Platform" - was published and documented in late 2013. Even though ethereum is also another cryptocurrency, the blockchain architecture behind ethereum was recognized for its ability to facilitate smart contracts, which are software-based functionalities that go beyond transactions in bitcoin system. The concept of smart contracts, in other words, has made ethereum a software architecture that could be used to create transparent, decentralized and fault tolerant software applications. Proof of Work (PoW) and Proof of Stake (PoS) are the most used consensus mechanisms in Ethereum. Proof of Work (PoW), similar to bitcoin, was the very first consensus protocol used in ethereum. However, it was seen later some attempts to shift to a different consensus mechanism called Proof of Stake (PoS). While Proof of Work (PoW) required solving a complex mathematical puzzle to generate and validate a new block, which consumed much computational energy, the Proof of Stake (PoS) consensus mechanism facilitated the creation of a new block by staking the wealth of the generating node.

3) Blockchain 3.0 (The Future): With promising success of smart contract based applications, blockchain has thrived across many industries. Going beyond cryptocurrency and smart contracts, the next generation of blockchain technology tries to resolve the contemporary problems such as

scalability, security, privacy and transparency which are found in various industries through an improved version of decentralized applications called DApps. Blockchain 3.0 could be considered as an improved version of blockchain 2.0 (Ethereum) and the DApps could be considered as its core.

#### B. The Blockchain Architecture

Blockchain architecture reveals all the substantive technical aspects behind blockchain. In blockchain the collection of transactions or digital information are recorded in chronological order in a block, which is linked with other similar blocks as a chain and secured using cryptography. SHA-256 cryptographic hashing algorithm is used to create a hash value for a block at the moment that particular block is generated. Each block in a blockchain has the hash value of the previous block in a way the blocks are linked and form as a chain. Each block is referencing to only one parent, but until the fork situation is resolved, it might have more than one child temporarily. A block can be identified in a blockchain by its cryptographic hash and block height. The very first block in the blockchain is known as the genesis block.

Structure of a block - Block is a data structure, which bundles the transactions and broadcast to all the nodes in the distributed decentralized network. A block contains a block header along with recorded transactions. Block header is a Metadata which helps to verify and validate the block.

The block header is made up with three sets of Metadata (Antonopoulos et al., 2017). First, previous block hash, which is 32 bytes in size, and it refers to the previous block or parents hash in the chain. Second is a set of Metadata, each with size of 4 bytes, namely 1). Difficulty target, which is a parameter defined by a hash below a given target, 2). Timestamp, which is the creation time of a

particular block and 3). Nonce, which is “number only used once” added with hash to meet the difficulty. Third, the merkle root, which is a 32 bytes size binary hash tree that summarizes all the recorded transactions in a particular block.

Once the transaction is initiated, it is stored in the transaction pool until it become confirmed. Miners, who attempt to create new blocks by solving the mathematical puzzle, on the network choose transactions from the transaction pool and form them into a new block, which they just mined. The validity of a new block added to the blockchain comes from a process known as consensus. In other words, a new block is chained with the blockchain only if it got the consensus of the majority of nodes attached to the respective blockchain network. Once a block is validated and added to the chain it turned to be immutable

The consensus mechanism plays a critical role in a blockchain. The traditional consensus mechanisms suffer from the drawback called 51% attack, which means the possibility of accepting a false block with majority’s consensus fraudulently. Therefore, different other consensus mechanisms have been developed, particularly with the advent of smart contracts and decentralized applications, for different classes of problems. Moreover, the nature of distributed applications demands the elimination of the role of miner in the bitcoin architecture and the alternative approaches are sought after as a result.

### **Consensus Mechanism**

A consensus mechanism is a fault-tolerant mechanism which is used to reach a common legitimate agreement between nodes in a peer-to-peer, network-based distributed decentralized system such as blockchain. For example, having a consensus mechanism enables to overcome the issue of double spending in bitcoin transactions, which

means making two payments using the same digital currency.

In literature, a notable study on the evolution of consensus mechanism/s has been presented by Leila Ismail et al. They have analyzed and provided a temporal evolution of the blockchain consensus protocols, classifying them into three main categories (Ismail et al., 2019) namely 1) compute-intensive based consensus protocols (insist massive computational power based consensus mechanisms), 2) capability based consensus protocols (potency based consensus mechanisms) and 3). Voting based consensus protocols.

Compute-intensive based consensus protocols are rivaling-based protocols that consume more energy, insist exorbitant cost for resources and contamination of environment, which are seen as its principal drawbacks (Monrat et al., 2019). Capability-based consensus mechanisms diminish the energy consumption problem, though it also has notable obstacles. It depends on capability, which indicates some possession of wealth, and hence is biased to rich and also may provide a chance to nasty attackers. Voting-based consensus protocols address the issues of high energy consumption in competitive based approach and avoid wealth dominance from capability based protocols by introducing a voting mechanism to attain a consensus.

#### **A. Proof of Work (PoW)**

The concept of Proof of Work (PoW) was introduced in 1993 by Cynthia Dwork and Moni Naor, when they published a science paper “Memory-Bound Functions for Fighting Spam”. Later in 1999, Markus Jakobsson and Ari Juels introduced the term “Proof of Work” in their paper “Proofs of work and bread pudding protocols”. After invention of bitcoin, Satoshi Nakamoto developed the PoW mechanism to confirm

transactions and add/mine new blocks to the bitcoin blockchain.

As described before, in this mechanism, to add a new block into existing chain minors are required to solve a complex puzzle (work) based on a cryptographic hash algorithm. The use of the SHA-256 algorithm expects minors guess a random number (nonce) and find the solution by using SHA256 function twice which is less than difficulty. This acts as a proof of the work done by the miner. The difficulty of the puzzle increases when the number of participants (minors) increase. After, validated all the transactions in the new block then the new block is then added to the blockchain. The person (node) who found the solution as soon as possible will be rewarded with bitcoin.

The detraction of Proof-of-Work are the threats of a 51% attack - malicious miners can seize 51% of the computing power of a network, gain so-called "domination" and get chance to won the chance , time consuming - solution comes in random selection of nonce which is time consuming process and resource consumption - to find the solution more computational power is needed

#### B. Proof of Stake (PoS)

In 2012, Sunny King and Scott Nadal introduced the concept of Proof of Stake (PoS) as a solution to "Bitcoin mining's high energy consumption". Sunny King introduced Peercoin as the first cryptocurrency to implement Proof of Stake in 2013(Cointelegraph, 2017). After the invention of ethereum, the ethereum developers were trying on the transition from Proof of Work to Proof of Stake through the Casper- test net version protocol. Casper was later upgraded into two - Casper FFG: (The Friendly Finality Gadget) and Casper CBC (The Friendly GHOST/Correct-by-Construction). Founder of ethereum explained both as - "The main trade-off

between FFG and CBC is that CBC seems to have nicer theoretical properties, but FFG seems to be easier to implement" (Antonopoulos et al., 2018).

Proof of Stake (PoS) protocol is developed as an alternative to the Proof of Work (PoW). In this mechanism, instead of minors, the participants are validators. Validators are chosen the next block by stake their tokens rather than mining. Those who stake large amount will get high chance to create next block. Since the validator no need to do mining hence Proof-of-Stake consume standard energy and became environmentally-friendly protocol which is alternative to Proof-of-Work.

The two main variants of Proof of Stake (PoS) mechanisms are Leased Proof of Stake (LPoS) and the Delegated Proof of Stake (DPoS) mechanisms. The flaws of Proof of Stake (PoS) are "Nothing at stake" problem (when validators try to create all possible forks) and "long-range attacks - The attacker tries to modify the history of the blockchain by creating a fork from the block already created" (Li et al., 2017).

#### C. Leased Proof of Stake (LPoS)

In 2017, Leased Proof of Stake (LPoS) is launched by Waves. In this mechanism, any nodes can lease their balances to staking nodes to make "richer gets richer" and will be rewarded with a percentage of the payout. Leased tokens remain in the full control of the leasing node and leases can be canceled at any time.

#### D. Delegated Proof of Stake (DPoS)

This method is introduced by Daniel Larimer in 2014 to overcome wealth dominance. Delegated Proof of Stake (DPoS) is similar to Proof of Stake (PoS). This mechanism works under voting and election process in an attempt to validating the blocks. Rather than staking or competing, nodes are work together to build and validate a new block.

Since limited number of participants are participating, this can potentially lead to 51% attack.

#### E. Proof of Burn (PoB)

Proof of Burn (PoB) was proposed by Ian Stewart in 2014 as an alternative consensus mechanism to overcome the problem of excessive energy consumption in Proof of Work (PoW). In this mechanism miners instead of wasting resources, burns their coins for mining and validation process. Once the miner burns the coins to the unspendable address which is called an eater address then it cannot be recovered. This intimidates the malicious nodes in the network who try to work on an invalid block. The drawback of this consensus is the rich becoming richer.

#### F. Proof of Elapsed Time (PoET)

In 2016, Intel invented the Proof of Elapsed Time (PoET) consensus protocol. In this mechanism, miners will be selected based on time. Each verification node sleeps after creation of a random wait time and the node completes the waiting time first receives a chance to propose the next block. Having to depend on Intel is the major drawback of this consensus mechanism.

#### G. Practical Byzantine Fault Tolerance (PBFT)

In 1999 Barbara Liskov and Miguel Castro introduced Practical Byzantine Fault Tolerance (PBFT) used to solve the Byzantine General problem (Castro et al., 1999). Among nodes in the network one node selected as a leader and rest of them are backup nodes. Once the leader node receives the transaction request, the transactions are bundled into block and the block is broadcast to the backup nodes for verification. If the majority or the 2/3 of the network found exact same hash then the new block is added to the existing chain. In this consensus transaction will be approved even if some nodes are malicious (not exceed  $\frac{1}{3}$  of the

overall nodes). When the number of nodes in the network increases, the system became more secure and efficient. The major threat found in this mechanism is the Sybil attack (Swathi et al., 2019).

#### H. Delegated Byzantine Fault Tolerance (DBFT)

Neo developed Delegated Byzantine Fault Tolerance (DBFT) in 2014 as a modified version of Practical Byzantine Fault Tolerance (PBFT), which differs only in terms of the mechanism to select the leader. Leader is selected through a voting process. In this mechanism some nodes in the network has the potential to record and verify transactions. It may create multiple malicious replica nodes. In this situation, Sybil attack may occur.

#### I. Hybrid Consensus Mechanisms

There is no such thing as “one consensus fits all”. Because each application domain may differ in terms of subjective. Despite single consensus mechanisms in the literature, hybrid type blockchain consensus mechanisms have been proposed to obtain efficient expected output while maintaining the decentralization such as Proof of Authority (PoAuthority), Proof of Weight (PoW), Proof of Activity (PoA), Delayed Proof-of-Work (DPoW), Delegated Proof of Stake (DPoS), Proof of Space (PoSpace) and few more. The objective of the hybrid consensus mechanism is to adopt the benefits of the respective consensus and aims to mitigate each other's weaknesses.

\*\*Table I illustrates the evolution of consensus mechanisms. It elaborates corresponding consensus for each classification, whether it is hybrid type or not and current usages.

Table 1: Evolution of Consensus

Evolution Type		Basis	Consensus algorithms	Hybrid	Used by
Compute-Intensive based consensus protocols		Huge computational power	Proof of Work(PoW-1993)	No	Bitcoin, Ethereum, Litecoin, Dogecoin
			Delayed Proof-of-Work(DPoW)	Yes (PoW-PoS)	Komodo
			Prime Number Proof of Work (Prime Number PoW-2013)	No	Primecoin
Capability-Based Consensus Protocols		Wealth dominance	Proof of Stake(PoS-2012)	No	Ethereum (soon), Peercoin, Nxt.
			Delegated Proof of Stake (DPoS-2014)	Yes (PoS-BFT)	Bitshares, Nano, Cardano
			Leased Proof of Stake (LPoS-2017)	No	Waves.
			Proof of Stake Velocity (PoSV-2014)	Unknown	Reddcoin
			Proof of Burn (PoB-2014)	Unknown	Slimcoin
			Proof of Space (PoSpace) / Proof of Capacity (PoC)(2015)	Yes (PoW-PoS)	Spacecoin, Chia, Burstcoin
			Proof of History (PoH-2017)	Unknown	Solana
			Proof of Importance (PoI-2018)	Unknown	NEM
			Proof of Believability (PoBelievability-2017)	Yes	IOST
			Proof of Authority (PoAuthority-2017)	Yes (PoS-BFT)	Gochain, Menlo one
			Proof of Elapsed Time (PoET-2016)	No	HyperLedger
			Proof of Weight (PoW)	Yes (PoS-BFT)	Algorand
Proof of Activity (PoA)	Yes (PoW-PoS)	Decred			
Voting-Based Consensus Protocols	Byzantine Fault Tolerance (BFT)-based protocols	Voting system	Practical Byzantine Fault Tolerance(PBFT-1999)	Unknown	Hyperledger Fabric, Hyperledger Iroha, Oracle, Hydrachain, BigchainDB
			Delegated Byzantine Fault Tolerance(DBFT-2014)	Unknown	NEO
			Federated Byzantine Agreement(FBA-2018)	Unknown	Ripple, Stellar
			Combined Delegated Proof of Stake and Byzantine Fault Tolerance (DPoS+BFT-2018)	Yes (DPoS-BFT)	
	Crash Fault Tolerance (CFT)-based protocols		Raft (2014)	Unknown	Quorum
			Federated CFT-based consensus(2014)	Unknown	

Choosing a precise consensus mechanism is mandatory to consolidate Decentralized Applications. Selection of an appropriate consensus mechanism depends on several factors such as prevention of double spending, hash power, scalability,

throughput, latency, energy efficiency, transaction verification, .etc.

- Double spending problem – Spending the same cryptocurrency more than once when doing digital transactions.



- Hash power – It is also called as Hash rate. It depends on the speed of the mining device. Its influences reveal, when a minor tries to compete to win a reward within a short period of time by solving a puzzle in order to try to add a new block to the existing chain.
- Scalability – Scalability depends on many factors. It influences directly to the throughput of the network and indirectly to the block size, response time and transaction fees.
- Throughput – Denotes the number successful transactions per second. It depends on block size, verification time, Block creation/ latency.
- Latency – It refers to the time interval between the transactions that are confirmed and deployed.
- Energy efficiency – It is used to determine which consensus algorithm uses how much energy from the resources.
- Transaction verification – It denotes the time a successful transaction takes for verification.

### **Previous Surveys and Analysis of Consensus Algorithms**

When looking at the existing literature, there are quite a few surveys and comparative analysis of various blockchain consensus mechanisms could be identified. For example, (Nguyen et al., 2018) has reviewed the popular consensus mechanisms and grouped them into two major categories namely, proof-based consensus and voting-based consensus and, has presented a comparison between PoW, PoS and their hybrid forms. (Yadav et al., 2020) also have presented a comparative analysis. They have compared the consensus mechanisms based on the notion of permissioned networks and permission less networks. In another comparative evaluation of consensus

mechanisms done by (Hazari et al., 2019), it has revealed that the PoW is the most widely used consensus algorithm in cryptocurrencies and the advancement of decentralization and scalability of the network is opposite to each other. Direct Acyclic Graph (DAG) resolves this issue, even though some security issues still exist.

(Cao et al., 2020), have analyzed and compared PoW, PoS and DAG based blockchain in terms of the average time to generate a new block, the confirmation delay, the TPS and the confirmation failure probability. In (Ni et al., 2018), the authors have identified the gaps by mapping the security and performance characteristics of the consensus mechanisms and the challenges of integrating blockchain-based IoT (Internet of Things) applications. In their research, PoW, PoS, PBFT, PoET, DBT, Tendermint and IOTA protocols have been compared to verify which factors suit to merge with IoT systems. In (Mahood et al., 2020), the authors have identified the parameters such as blockchain type, transaction rate, scalability, adversary tolerance model, experimental setup, latency, throughput, bandwidth, communication model, communication complexity, attacks, energy consumption, mining, consensus category, and consensus finality to compare the blockchain consensus algorithms. In (Alsunaidi et al., 2019) authors have figured out the factors that affect the performance and security of the blockchain consensus algorithms.

Similar work has been done in (Bakman et al., 2020), state-of-the-art blockchain consensus algorithms and pros and cons of each consensus mechanisms have been reviewed. They have also proposed an analytic framework that consists of four different criteria to evaluate the consensus algorithms' performance including their throughput, the profitability of mining,

degree of decentralization and algorithms' securities and vulnerabilities.

There are a few more recent comparative studies published with similar results. Table II depicts a summary of existing comparative studies in terms of security and performance.

Table 2: Comparisons of existing studies

Factors Consensus	Prevent Double Spending	Hash Power	Scalability	High Throughput	High Latency	Energy Efficient	Fast Transaction Verification
Proof of Work (PoW)	[[Ni et al., 2018], [Hazari et al., 2019]]	[[Bakman et al., 2020]]				[[Bakman et al., 2020]]	
Proof of Stake (PoS)	[[Ni et al., 2018], [Hazari et al., 2019]]		[[Hazari et al., 2019]]	[[Bakman et al., 2020]]		[[Ni et al., 2018], [Hazari et al., 2019], [Yadav et al., 2020], [Cao et al., 2020]]	[[Bakman et al., 2020]]
Delegated Proof of Stake (DPoS)	[[Bakman et al., 2020]]		[[Hazari et al., 2019], [Bach et al., 2018], [Bakman et al., 2020]]	[[Bach et al., 2018]]			
Proof of Elapsed Time (PoET)	[[Ni et al., 2018]]			[[Bakman et al., 2020], [Nguyen et al., 2018]]		[[Ni et al., 2018], [Yadav et al., 2020]]	[[Bakman et al., 2020], [Nguyen et al., 2018]]
Practical Byzantine Fault Tolerance (PBFT)	[[Ni et al., 2018], [Bach et al., 2018]]			[[Ni et al., 2018], [Bakman et al., 2020]]		[[Ni et al., 2018], [Bakman et al., 2020]]	[[Bakman et al., 2020]]

Prevent Double Spending	Hash Power	Scalability	High Throughput	High Latency	Energy Efficient	Fast Transaction Verification
PoW	PoS DPoS	PoS DPoS PoET PBFT	PoS DPoS PoET PBFT	PoS DPoS PoET PBFT	PoS DPoS PoET PBFT	PoS DPoS PoET PBFT
				PoW		
			PoS DPoS		PoS	PoS
					PoS PoET PBFT	PoS PoET PBFT
						PoS PoET PBFT

Figure 1: Reorganization of Consensus Mechanisms

Based on the results of the review of the existing comparative studies, it is possible to reorganize the existing consensus mechanisms into a grid as depicted by Figure 1. Such a reorganization is expected to help

the researchers to identify the most appropriate consensus mechanism for a particular application with a given set of performance and security requirements.

### Discussion

The review of existing consensus mechanism reveals that each and every consensus mechanism have different shortcomings. There is no consensus mechanism, which satisfies all the performance and security characteristics. As a solution, many hybrid consensus mechanisms have been proposed. However, the existing hybrid consensus mechanisms have not been empirically evaluated. They were compared only using theoretical aspects. Furthermore, a judicious technical study on performance analysis is needed. Identification of performance and security characteristics of existing consensus mechanism have led to select an appropriate consensus mechanism.

### Conclusion

This work is expected to serve as a guideline for further understanding on blockchain consensus mechanisms and their unique security and performance characteristics. This paper, starting with a background study of blockchain technology, analyses the mainstream consensus mechanisms. The result is a reorganization of the existing consensus protocols so that, one might choose the most appropriate consensus mechanism for the application being developed considering multiple performance and security factors. Especially in the era of DApps, such a guidance is necessary since the nature of the application could vary and so as its requirements when selecting the consensus mechanism. Our future work will look in to the use of these findings to select the most appropriate consensus mechanism for a smart food supply chain in the organic food industry.

### References

- Alsunaidi, S. and Alhaidari, F., 2019. A Survey of Consensus Algorithms for Blockchain Technology. International Conference on Computer and Information Sciences (ICCIS), pp.1-6.
- Antonopoulos, A. M. and Wood, G. D., 2018. Mastering Ethereum. 1st ed. O'Reilly Media.
- Antonopoulos, A., 2017. Mastering Bitcoin. 2nd ed. O'Reilly Media, Inc.
- Bach, L., Mihaljevic, B. and Zagar, M., 2018. Comparative analysis of blockchain consensus algorithms. 41st International Convention on Information and Communication Technology, Electronics and Microelectronics (MIPRO), Opatija, 2018, pp. 1545-1550, doi: 10.23919/MIPRO.2018.8400278.
- Buterin, V., 2014. Ethereum: A next-generation cryptocurrency and decentralized application platform. Bitcoin Magazine, 23.
- Buterin, V., Reijbergen, D., Piliouras, G., 2020. Incentives in Ethereum's hybrid Casper protocol. International Journal of Network Management. doi:10.1002/nem.2098
- CAI, W., Wang, Z., Leung, V.C., 2018. Decentralized Applications: The Blockchain-Empowered Software System. IEEE Access 6, 53019–53033. doi:10.1109/ACCESS.2018.2870644
- Cao, B., Zhang, Z., Feng, D., Zhang, S., Zhang, L., Peng, M. and Li, Y. 2020. Performance analysis and comparison of PoW, PoS and DAG based blockchains. Digital Communications and Networks.
- Castro, M., Liskov, B., 1999. Practical Byzantine Fault Tolerance. Proceedings of the Symposium on Operating System Design and Implementation 1–14. doi:10.1145/571637.571640
- Chaudhry, N. and Yousaf, M., 2018. Consensus Algorithms in Blockchain: Comparative Analysis, Challenges and Opportunities. 12th International Conference on Open Source Systems and Technologies (ICOSST), pp.54-63, doi: 10.1109/ICOSST.2018.8632190.
- CoinDesk. 2020. Bitcoin 101 - Coindesk. [Online] Available at: <<https://www.coindesk.com/learn/bitcoin-101/what-is-bitcoin>> [Accessed 5 March 2020].
- Cointelegraph. 2017. The History and Evolution of Proof-Of-Stake. [Online] Available at: <<https://cointelegraph.com/news/the-history-and-evolution-of-proof-of-stake>> [Accessed 21 April 2020].
- Deirmentzoglou, E., Papakyriakopoulos, G. & Patsakis, C. 2019. A Survey on Long-Range Attacks for Proof of Stake Protocols. IEEE Access, 7, 28712-28725.
- Gai, F., Wang, B., Deng, W. & Peng, W. 2018. Proof of Reputation: A Reputation-Based Consensus Protocol for Peer-to-Peer Network. Database Systems for Advanced Applications.
- Guo, H., Zheng, H., Xu, K., Kong, X., Liu, J., Liu, F. & Gai, K. 2018. An Improved Consensus Mechanism for Blockchain. Smart Blockchain.
- Hao, Y., Li, Y., Dong, X., Fang, L. and Chen, P., 2018. Performance Analysis of Consensus Algorithm in Private Blockchain. IEEE Intelligent Vehicles Symposium (IV), pp. 280-285, doi: 10.1109/IVS.2018.8500557.
- Hazari, S. and Mahmoud, Q., 2019. Comparative evaluation of consensus mechanisms in cryptocurrencies. Internet Technology Letters, 2(3), p.e100.
- Hooda, P. Proof of Work (Pow) Consensus - Geeksforgeeks. [Online] GeeksforGeeks. Available at: <<https://www.geeksforgeeks.org/proof-of-work-pow-consensus/>> [Accessed 30 May 2020].
- Investopedia, 2018. Double-Spending Definition [WWW Document]. Investopedia Dictionary. URL <https://www.investopedia.com/terms/d/doublespending.asp>.
- Ismail, Materwala, 2019. Article, A Review of Blockchain Architecture and Consensus Protocols : Use Cases, Challenges, and Solutions. Symmetry, 11(10), p.1198.
- Judmayer, A., Stifter, N., Krombholz, K. and Weippl, E., 2017. Blocks And Chains: Introduction To Bitcoin, Cryptocurrencies, And Their Consensus Mechanisms. Morgan & Claypool.
- Karamat, S. and Heal, J., 2020. A Brief History of Ethereum - Coin Rivet Guide to the Creation of Ethereum. [Online] Coin Rivet. Available at: <<https://coinrivet.com/guides/cryptocurrencies/a-brief-history-of-ethereum/>> [Accessed 15 March 2020].

- Knoema. 2020. Bitcoin Price from 2009 to 2019 - Knoema.Com. [Online] Available at: <<https://knoema.com/nmyfsf/bitcoin-price-from-2009-to-2019>> [Accessed 5 March 2020].
- Kostal, K., Krupa, T., Gembec, M., Veres, I., Ries, M. and Kotuliak, I., 2018. On Transition between PoW and PoS. 2018 International Symposium ELMAR, pp. 207-210, doi: 10.23919/ELMAR.2018.8534642.
- Li, K., Li, H., Hou, H., Li, K. & Chen, Y. 2017. Proof of Vote: A High-Performance Consensus Protocol Based on Vote Mechanism & Consortium Blockchain. 2017 IEEE 19th International Conference on High Performance Computing and Communications; IEEE 15th International Conference on Smart City; IEEE 3rd International Conference on Data Science and Systems (HPCC/SmartCity/DSS).
- Li, W., Andreina, S., ... Karame, G., 2017. Securing proof-of-stake blockchain protocols, in: Lecture Notes in Computer Science (Including Subseries Lecture Notes in Artificial Intelligence and Lecture Notes in Bioinformatics). Springer Verlag, pp. 297-315. Doi:10.1007/978-3-319-67816-0\_17
- Mahajan, D. 2019. A Survey Paper on Blockchain Technology. International Journal for Research in Applied Science and Engineering Technology, 7, 3564-3569.
- Mahmood W, Wahab A. 2020 Survey of Consensus Protocols. SSRN Electronic Journal.
- Mingxiao, D., Xiaofeng, M., Zhe, Z., Xiangwei, W. and Qijun, c., 2017. A review on consensus algorithm of blockchain. In: IEEE International Conference on Systems. pp.2567-2572.
- Monrat, A. A., Schelen, O. & Andersson, K. 2019. A Survey of Blockchain from the Perspectives of Applications, Challenges, and Opportunities. IEEE Access, 7, 117134-117151.
- Nakamoto, S., 2009. Bitcoin: A Peer-To-Peer Electronic Cash System. [Online] Bitcoin.org. Available at: <<https://bitcoin.org/bitcoin.pdf>> [Accessed 20 December 2019].
- Nguyen, C. T., Hoang, D. T., Nguyen, D. N., Niyato, D., Nguyen, H. T. & Dutkiewicz, E. 2019. Proof-of-Stake Consensus Mechanisms for Future Blockchain Networks: Fundamentals, Applications and Opportunities. IEEE Access, 7, 85727-85745.
- Nguyen, G. and Kim, K., 2018. A Survey about Consensus Algorithms Used in Blockchain. Journal of Information Processing Systems, 14(1), pp.101-128.
- Ni, W., Abolhasan, M. & Makhdoom, I. 2018. Blockchain for IoT: The Challenges and a Way Forward. Proceedings of the 15th International Joint Conference on e-Business and Telecommunications.
- Sadek Ferdous, M., Javed Morshed Chowdhury, M., Hoque, M. and Colman, A., 2020. Blockchain Consensus Algorithms: A Survey. [Online] NASA/ADS. Available at: <https://ui.adsabs.harvard.edu/abs/2020arXiv200107091S/abstract> [Accessed 26 March 2020].
- Saleh, F., 2018. Blockchain without Waste: Proof-of-Stake. SSRN Electronic Journal. doi:10.2139/ssrn.3183935
- Swathi, P., Modi, C., Patel, D., 2019. Preventing Sybil Attack in Blockchain using Distributed Behavior Monitoring of Miners, in: 2019 10th International Conference on Computing, Communication and Networking Technologies, ICCCNT 2019. Institute of Electrical and Electronics Engineers Inc. doi:10.1109/ICCCNT.45670.2019.8944507.
- Wang, W., Hoang, D. T., Hu, P., Xiong, Z., Niyato, D., Wang, P., Wen, Y. & Kim, D. I. 2019. A Survey on Consensus Mechanisms and Mining Strategy Management in Blockchain Networks. IEEE Access, 7, 22328-22370.
- Wood, G., 2014. Ethereum: A secure decentralised generalised transaction ledger. Ethereum project yellow paper, 151(2014), pp.1-32.
- Wu, Y., Song, P., Wang, F., 2020. Hybrid Consensus Algorithm Optimization: A Mathematical Method Based on POS and PBFT and Its Application in Blockchain. Mathematical Problems in Engineering 2020. doi:10.1155/2020/7270624
- Xiao, Y., Zhang, N., Lou, W. & Hou, Y. T. 2020. A Survey of Distributed Consensus Protocols for Blockchain.
- Xu, X., Weber, I. and Staples, M., 2020. Architecture for Blockchain Applications | Springerlink. [Online] Doi.org. Available at:

<<https://doi.org/10.1007/978-3-030-03035-3>>  
[Accessed 12 February 2020].

Yadav, A. K. And Singh, K., 2020. Comparative Analysis of Consensus Algorithms of Blockchain Technology. *Advances in Intelligent Systems and Computing*, pp.205-218.

### Acknowledgement

This research was supported by the Accelerating Higher Education Expansion and Development Operation (AHEAD) of the Ministry of Higher Education funded by the World Bank.

### Author Biographies



Thanushya Thanujan received B.Sc (Special) in Computer Science at Vavuniya Campus of the University of Jaffna and M.Sc in Computer Science

at the University of Peradeniya. Since 2016 she has been working as a lecturer (Prob.) in the Department of Computer Science, Faculty of Applied Science, Trincomalee Campus. Her research interests are Blockchain Technology, Internet of Things, Graph Theory Image Processing and Network Security.

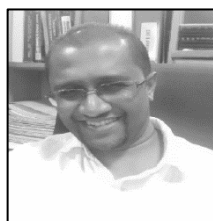

Chathura Rajapakse is a senior lecturer attached to the Department of Industrial Management, Faculty of Science, University of Kelaniya. He

is an alumna of the Tokyo Institute of Technology, Japan from where he received a Doctor of Engineering degree in Computational Intelligence and Systems Science in March 2015. He also possesses a Master of Engineering degree from the same university as well as a B.Sc. (Special) degree in Industrial Management from the University of Kelaniya, Sri Lanka. He is conducting research on smart and intelligent information systems since 2009.



Dilani Wickramaarachchi is a senior lecturer attached to the Department of Industrial Management, Faculty of Science, University of

Kelaniya. She is an alumna of the La Trobe University, Australia from where she received her PhD in Software Engineering in March 2015. She also possesses a Master of Science in Computer Science degree from the University of Colombo School of Computing(UCSC), Sri Lanka, as well as a B.Sc. (Special) degree in Industrial Management from the University of Kelaniya, Sri Lanka. Her research interests are in Global Software Engineering, Human learning through co-creation, Software code quality improvement, Computational thinking and Digital innovation.

## Social media sentiment analysis for customer purchasing behavior – A systematic literature review

M.A.L Manthirathna<sup>1#</sup>, W.M.H.G.T.C.K. Weerakoon<sup>2</sup>, R.M.K.T. Rathnayaka<sup>3</sup>

<sup>1</sup> Department of Computing and Information Systems, Sabaragamuwa University of Sri Lanka, Belihuloya, Sri Lanka

<sup>2,3</sup> Department of Physical Sciences and Technology, Sabaragamuwa University of Sri Lanka, Belihuloya, Sri Lanka

#manthirathna.mal@gmail.com

**Abstract:** Social Media Sentiment Analysis is a field of study with a vast number of applications. One important application is analysing customer behaviours using the results of social media sentiment analysis which is a great tool that decision-makers can utilize. There are several studies conducted about this field. This paper presents the results of a systematic literature review conducted on the existing studies which would be beneficial for developers and researchers interested in this field. This is a preliminary SLR in which, research papers published in journals and conferences until 2020 were collected from 7 electrical databases. Initially, 86 studies were found and 5 most relevant studies derived through specific inclusion and exclusion criteria were investigated to analyse the current status of research, approaches and methods used, results, limitations, existing gaps and future recommendations by researchers. The results of this study suggest that hybrid models that combine lexicons and machine learning classification models produce more accurate results in sentiments analysis. Researchers have attempted to conduct sentiment analysis considering various components of social media text data: punctuation, emoji and emoticons, negations, acronyms and slangs etc. Most studies focus on various applications of social media sentiment analysis beneficial for understanding and interacting with customers. Such as identifying how cultural

and economical differences, occurrence of various events impact consumer purchasing behaviours, dealing with negative sentiment shifts, segmenting consumers into groups and even predicting sales performance etc. This study makes a significant contribution by providing a comprehensive and up-to-date review of the previous attempts made in the selected domain.

**Key Words:** systematic literature review, sentiment analysis, social media, purchasing behaviour

### Introduction

3.484 billion of people around the world use Social Media by the end of 2019 and this number will be increased by 9% each year. Social media users freely express and share their ideas on social media creating zeta bytes of data. These data led way to Social Media Sentiment Analysis which generates valuable insights about data creators that would otherwise stay hidden. Businesses around the world have been increasingly using social media data to understand their customers and to generate business intelligence.

#### A. Sentiment Analysis

Sentiment analysis is also known as opinion mining and is a sub-domain of Natural Language Processing. It aims to derive the writers' opinion, emotions or attitudes from a text including the degree of positivity or negativity of the sentiment (Liu 2012).

According to (Wolny 2016), (Pang & Lee 2008) it can also be used to identify if a text is subjective or objective. Sentiment analysis results are applied for a variety of purposes. Analysing movie reviews, product reviews, blogs and news etc.

#### B. Social Media Sentiment Analysis

At present social media platforms are spread everywhere within the globe. The digital age that we are currently living in has nourished the fast growth of social media. Approximately 2.82 billion people are actively using social media in 2018 worldwide. This number will be increased to 2.93 billion in 2020. Users freely express their ideas, attitudes, emotions and opinions about anything and everything in these social media platforms. This creates a massive amount of user-generated content which fall under the category of big data. When the sentiments contained in this huge amount of text data are analyzed properly the results produce valuable insights that can be applied in many fields. Product recommendations, stock prices prediction, sales prediction, election results prediction, public health planning, economic forecasting, political analysis, disaster predictions are few of them.

However, social media sentiment analysis includes its' own benefits and limitations. For example, gathering data is relatively easier and is of low cost. There is content freely available about any topic. In the negative side, in some geographical areas, especially under developing countries social media does not represent the opinion of the general public as the majority of the population using social media tend to be younger and socio-economically privileged (Gayo-Avello, Metaxas & Mustafaraj 2011). In addition, language changes are harder to analyse. Social media data is also unstructured, high volume and noisy thus traditional methods are powerless in analysing them (Ibrahim & Wang 2019). Thus, machine learning

approaches are frequently used by researchers.

#### C. Social Media Sentiment Analysis for Customer Behaviour

Social media sentiment analysis provides valuable insights related to customer behaviours. Social media is so integrated with human lives, serves as a main method of communication and affects all the kinds of human activities (Lassen, Madsen & Vatrapu 2014). As mentioned in (Arora, Li & Neville 2015) most users express their opinions about different brands, products and services on social media platforms. Users freely and frequently create and share content on what they purchase, what features they like or dislike, how disappointed or pleased they are with a specific brand etc. When analysed properly, these users generated content which is in the form of comments, posts, likes, tweets or retweets uncovers hidden knowledge that decision-makers can utilize for the success of their businesses.

Emotions are what drives human in everything they do, including making purchasing decisions. The emotion, opinion or sentiment they have about a specific product or service determines whether they make a purchase or not. Their emotions are affected by the opinion of both leading figures and the general public thus their decision-making process is also affected by both (Feldman 2013). Thus closely monitoring social media data which represents the opinion of the customer base is critical for a successful business firm. Firms can become aware of shifts in customer sentiment and react accordingly to reduce harmful effects. They can also utilize it as a performance evaluator: to identify what products and services need to be improved the degree to which customers' needs are met and the successfulness of their market strategies. Social media sentiment analysis is utilized as a market research tool

by analysing customers’ sentiment about competitors. Hidden patterns and knowledge from social media sentiment analysis results provide firms with a competitive advantage. Conducting a systematic literature review which identifies the current status of existing literature in this domain including limitations, barriers and gaps in the existing researches will provide a solid foundation for prospective researches. Mainly, this study identifies approaches and technologies used, applications of social media sentiment analysis related to customer insights, limitations and barriers faced by researchers. This is an up-to-date and comprehensive record of existing research attempts made related to this domain that provides a significant contribution to existing knowledge.

*Table 1: Search strings used to fetch studies*

### Methodology and Experimental Design

Area	Search Term
Customer Purchasing Behavior	“customer purchasing behaviour”, “customer buying pattern”
Social Media Sentiment Analysis	“social media sentiment analysis” “social media opinion mining” “microblogging sentiment analysis” “microblogging opinion mining”
Full search string	(“customer purchasing behaviour” OR “customer buying pattern”) AND (“social media sentiment analysis” OR “social media opinion mining” OR “microblogging sentiment analysis” OR “microblogging opinion mining”)

This study was conducted following the methodology given in (Kitchenham 2004) to conduct a Systematic Literature Review. The following are the steps followed.

#### A. The strategy of Literature Search

As mentioned earlier, plenty of studies are already conducted under this field. Application of a smart searching strategy allows retrieving many of them as possible.

#### B. Sources

The following sources were queried to fetch existing studies

- i. Emerald Insight  
(<http://emeraldinsight.com>)
- ii. Science Direct  
(<https://www.sciencedirect.com>)
- iii. Research Gate  
(<https://www.researchgate.net>)
- iv. IEEE Xplore  
(<http://ieeexplore.ieee.org>)
- v. Springer Link  
(<https://link.springer.com>)
- vi. ACM Digital Library  
(<https://dl.acm.org>)
- vii. GoogleScholar  
(<https://www.scholar.google.com>)

At the end of the search process, a total of 86 number of papers were found. The statistics are as following: IEEE Xplore-23, Research Gate-9, Springer Link-5, Science Direct-19, Emerald Insight-6, ACM Digital Library-5, Google Scholar-19.

#### C. Inclusion and Exclusion Criteria

Studies to be included and excluded for this review were determined under the following criteria.

##### Inclusion Criteria

IC1 - Publications from above mentioned digital libraries related to identifying customer purchasing behaviours using social media sentiment analysis were included.

IC2 - Publications published from 2007 to 2020 were included

##### Exclusion Criteria

EC1- The study does not have an abstract.

EC2- study is not written in English.

EC3- The study is an older version of another study already considered.



EC4- The study is not primary.

EC5- Removing multiple versions of the same article from different libraries.

**D. Data exaction and synthesis method**

Following steps were followed to exact and synthesize data from research papers.

- i. Articles were fetched as in IC1 using the search strings mentioned in section C.
- ii. Articles complying to IC2 were shortlisted.
- iii. EC1, EC2, EC3, EC4 and EC5 were applied to shortlist the best suitable articles.
- iv. Each selected article was analyzed under the research questions mentioned in section E, with the aid of a form.
- v. All the results were arranged and sorted.

**E. Research Questions**

In this review, the following research questions are addressed.

RQ1: What are the aspects that had been covered in the existing researches regarding social media sentiment analysis for customer purchasing behaviour?

RQ2: What are the issues/limitations the previous researchers had to face in this field of study?

RQ3: What are the applications of knowledge generated in previous research?

RQ4: What are the technologies/methods /approaches used to conduct this type of research?

RQ5: What are the main conclusions drawn from existing studies?

**Results**

This section presents the findings of this study based on the answers for each research question and summary of selected literature.

RQ1: What are the aspects that had been covered in the existing researches regarding social media sentiment analysis?

*Table 2: Outcomes of selection stages*

Stage	Criteria	Analyzed Content	Initial no of studies	Final no of studies
1 <sup>st</sup>	IC1, IC2, EC1, EC2	Title, Abstract, Keywords	86	64
2 <sup>nd</sup>	IC1, IC2, EC3, EC5	Title, Abstract, Keywords	64	19
3 <sup>rd</sup>	IC1, IC2, Snowballing, EC4	Full text, Title, Abstract, Keywords	19	4
4 <sup>th</sup>	Research group, IC1, IC2, EC4	Full text	4 (added by Snowballing)	1 (added by Snowballing)
5 <sup>th</sup>	IC1, IC2, EC1, EC3, EC4	Full text	3 (added by Research group)	0 (added by Research group)
Final			86+4+3 = 93	4+1+0 = 5

Former studies were conducted on identifying the best method between different methods that can be used (Zul, Yulia & Nuralmasari 2018), creating more efficient and accurate frameworks and approaches (Chang et al. 2019), (Eder, Guigas & Debeye 2019), (Tan, Hong & Tan 2012), different tools that can be used to conduct sentiment analysis (Peacock & Khan 2019), different applications of analysis results: generating competitive intelligence (Part 2010), predicting consumer confidence (Shayaa et al. 2018), analysing the characteristics of consumers of different cultures (Zhong et al. 2019), evaluating social media brand presence (Pletikosa Cvijikj, Dubach Spiegler & Michahelles 2013), using emojis and emoticons for emotion mining (Zhang et al. 2013), (Alita, Priyanta & Rokhman 2019), (Solakidis, Vavliakis & Mitkas 2014).

RQ2: What are the issues/limitations the previous researchers had to face in this field of study?

If the research was conducted using a lexicon-based approach for sentiment analysis then the final result heavily depends on the words of the lexicon. A framework built on lexicon approach would fail to classify any word that is not in the lexicon. A language is a complex intellectual that is constantly changing. The meanings of words depend on the context it is being used in. Sarcasm detection, handling multilingualism (80% of researches done are for English language, sentiment analysis using other languages is very less), identifying spellings mistakes, handling negations, handling acronyms and slang language (social media content is mostly written informal language with terms like “Lol”, “Ha ha”, “Bff” with sentiments in them but traditional lexicons are not capable of understanding them), handling lexical variations (same word written in multiple ways eg: gdn8, good night, gdnt) are difficulties faced by researchers (Yadav & Pandya 2017). Researchers in this field of study must address all these issues in natural language processing. On the other hand in some countries social media are not used by the entire population, mostly younger and socio-economically benefited people tend to be active social media users (Gayo-Avello, Metaxas & Mustafaraj 2011). Hence, making conclusions about the entire customer base is questionable.

The English language had been the focus of a comparatively very large number of studies. This causes the English language to have more attenuated datasets than other languages. So, because of this, using automated systems to analyse sentiments in other languages will result in low accuracy. (Mohammad 2016)

RQ3: What are the applications of knowledge generated from previous research?

Results of analysing social media sentiment for customer purchasing behaviour are applied in every place where awareness of

the sentiment or the opinion of the customers is critical. For example (Zhong et al. 2019) analyses differences in customer sentiment in different cultures for the same product- this result is useful to marketers and decision-makers. Another study (Ibrahim and Wang, 2019) analyses customer sentiments in a timely manner to discover the effect of events that occur to the customers' opinion. Exploring trends in customer sentiment is also very useful (Ibrahim & Wang 2019). Measuring consumer confidence via customer sentiment is another application (Shayaa et al. 2018). Sales and marketing performance can be analysed using customer sentiment (Part 2010). Another very useful application is predicting customer purchasing behaviours using customer sentiment analysis results.

RQ4: What are the technologies/methods /approaches used to conduct researches related to this field?

Various researchers have followed different approaches

for sentiment classification: machine learning-based methods (Naïve-Bayes, Support Vector Machine, K-mean, K-nearest neighbour, Logistic Regression, Decision trees), lexicon-based methods and Hybrid methods that combine both lexicons and machine learning models. Machine learning gives computers the ability to learn by themselves without being explicitly programmed algorithms require a large amount of training data set.

The other approach, Lexicon means a vocabulary. This type of approaches use lexicons for calculating polarity of individual words and aggregate their scores to determine the overall polarity of text. Lexicon based approaches are further classified as corpus-based and dictionary-based lexicon approaches (Wang et al. 2014).

Table 3: Bibliographic References

Paper Id	Bibliographic Reference
#1	Zhong, Q. <i>et al.</i> (2019) 'Using online reviews to explore consumer purchasing behaviour in different cultural settings', <i>Kybernetes</i> , 48(6), pp. 1242–1263. doi: 10.1108/K-03-2018-0117
#2	Ibrahim, N. F. and Wang, X. (2019) 'Decoding the sentiment dynamics of online retailing customers: Time series analysis of social media', <i>Computers in Human Behavior</i> . Elsevier, 96(October 2018), pp. 32–45. doi: 10.1016/j.chb.2019.02.004.
#3	Elkhunni, M. (2015) 'Visualizing in Twitter Sentiment To Measure Consumer Insight Visualizing in Twitter Sentiment to Measure Consumer Insight Mustafa Bashir B El-Khunni Department of Computer Science', (September 2013), pp. 0–108. doi: 10.13140/RG.2.1.1809.1044.
#4	Shayaa, S. <i>et al.</i> (2018) 'Linking consumer confidence index and social media sentiment analysis', <i>Cogent Business and Management</i> . Cogent, 5(1), pp. 1–12. doi: 10.1080/23311975.2018.1509424.
#5	Setiya, K., Ubacht, J., Cunningham, S. and Oruç, S., 2016. Business Intelligence from User Generated Content: Online Opinion Formation in Purchasing Decisions in High-Tech Markets. <i>Social Media: The Good, the Bad, and the Ugly</i> , pp.505-521.

Table 4: Summary of selected studies

are small icons that can be anything: faces,

Paper Id	Method/Tools	Application/Results	Context	Limitations
#1	Lexicon	Proves that customers from different cultures have different levels of emotions and pay different level of attention to the same product.	Online reviews	Better feature lexicons should be made with network surveys and expert advice. Need a way to analyze real-time data
#2	Combination of time series analysis, sentiment analysis (using lexicon) and topic modelling	Explore trends in Tweets volume and sentiments to provide an understanding of online retailing customer behaviour	Twitter	Only focus on Twitter users, need to involve other user groups using surveys and interviews
#3	Lexicon (WordNik) and machine learning models (Naïve Bayes, Support Vector Machine)	Classifier to measure consumer insight.	Twitter	Lexicon phrases and vocabulary sets in the database are not fully included due to time limitations
#4	Supervised Machine Learning based classifier	Proves there's a significant correlation between the official Consumer Confidence Index and social media big data (via sentiment analysis) on consumer purchasing behaviour	Twitter	The method used to obtain Consumer Confidence Index data is time-consuming and costly and is not generalizable enough
#5	Poisson Regression and sentiment analysis(using natural language processing techniques)	A conceptual model for deriving business intelligence from tweets, to understand the influence of online opinion formation on customer purchasing decisions	Twitter	Need data from various social media sources to cover wider demographics and need data from other products to generalize the modal

In the lexicon-based approach, no prior information or training data is needed. It is proved that hybrid approaches provide the best accuracy for prediction.

Sentiment analysis using data other than the words in the content is another technique. Social media users tend to add emoticons and emoji to express emotions in their tweets and posts. Emoticons are emotions presented using standard ASCII character set, only basic emotions can be presented with them. Emoji

trees, sun etc. (Peacock & Khan 2019). Analysing these has been used as a great way to discover the emotion in a text (Solakidis, Vavliakis & Mitkas 2014), (Hogenboom et al. 2013).

Programming languages R and Python are adopted by many researches as they have inbuilt packages suitable for sentiment analysis. SentiStrength, NodeXL Pro, MALLET LDA and Vader are used by many researchers as tools for conducting SMSA.

RQ5: What are the main conclusions drawn from existing studies?

Even though this field of study has been discussed for a long period, the highest accuracy of the sentiments generated vary between 80% to 96%. Despite the number of researches being conducted in this field, still, there is room for novelty and aspects that need improvement. Most studies only utilize words for generating sentiment, only a limited number of studies attempt to utilize all words, emoticons, negations and punctuations that appear in almost all user generate content on social media. This is a significant gap since emoticons, negations and punctuations have a great impact on sentiment analysis as proven by (Zhang et al. 2013), (Liu & Zhang 2012). People post their views, opinions and emotions on social networking sites such as Facebook (Akaichi 2013) and Twitter with a wide use of emojis (Hogenboom et al. 2013) thus including them in sentiment analysis would be highly beneficial.

Regarding the type of approaches being used, machine learning approaches are more accurate than lexicon-based approaches and hybrid approaches produce the highest accuracy. Using extended lexicons is another way to increase accuracy.

### **Discussion and Conclusion**

Social media sentiment analysis is a very broadly discussed topic by researchers, studies have been conducted continuously utilizing various methods and techniques. In this SLR 86 number of studies from libraries: ResearchGate, Emerald Insight, ScienceDirect, IEEE Xplore, Google Scholar, ACM Digital Library and SpringerLink were initially taken into consideration and 5 were shortlisted for complete analysis under the research questions mentioned in section E. Even though a large number of researches have been conducted related to social media sentiment analysis, few seem to concern about customer purchasing behaviours.

Existing researches are conducted on using words, punctuations, emoji and emoticons to increase the accuracy of sentiment analysis, detecting and removing sarcasm and fake content to increase accuracy, identifying the reasons behind sentiments, predicting sentiments, how to fix issues arising in customer purchasing behaviours as an impact of sentiment shifts, using sentiment analysis to identify characteristics of various consumer groups.

Most of the researches only focus on classifying sentiment as negative, positive or neutral. Lesser number of researches try to declare the intensity of negativity or positivity. Majority of the researches were conducted using the English language. Analysis of social media text data that are in other languages was comparably low.

The issues that arise in natural language processing techniques are all in sentiment analysis. For a successful implementation, researchers have to overcome these barriers. Also, they have to deal with picture icons, slang and acronyms that appear in social media data.

Studies that used hybrid models that combine both lexicons and machine learning models and extended lexicons achieved the highest accuracy. Naïve Bayes, Logistic Regression, Support Vector Machine, K Nearest Neighbours are among the most popular machine learning classifiers. Other than base classifiers, ensembling techniques are also used to increase performance. SentiStrength, NodeXL Pro, MALLET LDA and Vadar are the commonly used tools for sentiment analysis.

It is believed that the findings of this mapping study would contribute to improving existing applications of social media sentiment analysis for customer purchasing behaviours and enable the research community to better address the existing limitations and challenges.

## References

- Akaichi, J. 2013, Social Networks ' Facebook ' Statutes Updates Mining for Sentiment Classification, pp. 2-7.
- Alita, D., Priyanta, S. & Rokhman, N. 2019, 'Analysis of Emoticon and Sarcasm Effect on Sentiment Analysis of Indonesian Language on Twitter', Journal of Information Systems Engineering and Business Intelligence, vol. 5, no. 2, p. 100.
- Arora, D., Li, K.F. & Neville, S.W. 2015, 'Consumers' sentiment analysis of popular phone brands and operating system preference using twitter data: A feasibility study', Proceedings - International Conference on Advanced Information Networking and Applications, AINA.
- Chang, Y.C., Yeh, W.C., Hsing, Y.C. & Wang, C.A. 2019, 'Refined distributed emotion vector representation for social media sentiment analysis', PLoS ONE, vol. 14, no. 10, pp. 1-22.
- Eder, T., Guigas, P.V. & Debeye, D. 2019, Improvement of automated social media sentiment analysis methods - a context-based approach, no. November, pp. 11-22.
- Feldman, R. 2013, 'Techniques and applications for sentiment analysis', Communications of the ACM.
- Gayo-Avello, D., Metaxas, P.T. & Mustafaraj, E. 2011, 'Limits of Electoral Predictions using Social Media Data', Proceedings of the Fifth International AAAI Conference on Weblogs and Social Media.
- Hogenboom, A., Bal, D., Frasinca, F., Bal, M., De Jong, F. & Kaymak, U. 2013, 'Exploiting emoticons in sentiment analysis', Proceedings of the ACM Symposium on Applied Computing, no. March, pp. 703-10.
- Ibrahim, N.F. & Wang, X. 2019, 'Decoding the sentiment dynamics of online retailing customers: Time series analysis of social media', Computers in Human Behavior, vol. 96, no. October 2018, pp. 32-45.
- Kitchenham, B. 2004, 'Procedures for performing systematic reviews', Keele University, UK and National ICT Australia.
- Lassen, N.B., Madsen, R. & Vatrapu, R. 2014, 'Predicting iPhone Sales from iPhone Tweets', Proceedings . IEEE 18th international Enterprise Distributed object computing conference.
- Liu, B. 2012, 'Sentiment analysis and opinion mining', Synthesis Lectures on Human Language Technologies.
- Liu, B. & Zhang, L. 2012, 'A survey of opinion mining and sentiment analysis', Mining Text Data.
- Mohammad, S.M. 2016, 9. Sentiment Analysis: Detecting Valence, Emotions, and Other Affective States from Text, Emotion Measurement, Elsevier Ltd.
- Pang, B. & Lee, L. 2008, 'Opinion mining and sentiment analysis', Foundations and Trends in Information Retrieval.
- Peacock, D.C. & Khan, H.U. 2019, of Emoticon / Emoji, no. Itng, pp. 491-4.
- Pletikosa Cvijikj, I., Dubach Spiegler, E. & Michahelles, F. 2013, 'Evaluation framework for social media brand presence', Social Network Analysis and Mining, vol. 3, no. 4, pp. 1325-49.
- Shayaa, S., Ainin, S., Jaafar, N.I., Zakaria, S.B., Phoong, S.W., Yeong, W.C., Al-Garadi, M.A., Muhammad, A. & Zahid Piprani, A. 2018, 'Linking consumer confidence index and social media sentiment analysis', Cogent Business and Management, vol. 5, no. 1, pp. 1-12.
- Solakidis, G.S., Vavliakis, K.N. & Mitkas, P.A. 2014, 'Multilingual sentiment analysis using emoticons and keywords', Proceedings - 2014 IEEE/WIC/ACM International Joint Conference on Web Intelligence and Intelligent Agent Technology - Workshops, WI-IAT 2014, vol. 2, pp. 299-305.
- Tan, K.L., Hong, J.L. & Tan, E.X. 2012, 'A novel ontological technique for sentiment analysis', Lecture Notes in Computer Science (including subseries Lecture Notes in Artificial Intelligence and Lecture Notes in Bioinformatics), vol. 7663 LNCS, no. PART 1, pp. 339-46.
- Wang, Z, Tong, V.J.C., Wang, Zhaoxia, Joo, V. & Tong, C. 2014, Issues of Social Data Analytics with a New Method for Sentiment Analysis of Social Media Data Issues of social data analytics with a new method for sentiment analysis of social media data.
- Wolny, W. 2016, 'Emotion analysis of twitter data that use emoticons and emoji ideograms', 25th

International Conference on Information Systems Development, ISD 2016, no. August 2016, pp. 476–83.

Yadav, P. & Pandya, D. 2017, 'SentiReview: Sentiment analysis based on text and emoticons', IEEE International Conference on Innovative Mechanisms for Industry Applications, ICIMIA 2017 - Proceedings, no. December, pp. 467–72.

Zhang, L., Pei, S., Deng, L., Han, Y., Zhao, J. & Hong, F. 2013, 'Microblog sentiment analysis based on emoticon networks model', ACM International Conference Proceeding Series, pp. 134–8.

Zhong, Q., Liang, S., Cui, L., Chan, H.K. & Qiu, Y. 2019, 'Using online reviews to explore consumer purchasing behaviour in different cultural settings', *Kybernetes*, vol. 48, no. 6, pp. 1242–63.

Zul, M.I., Yulia, F. & Nurmalasari, D. 2018, 'Social media sentiment analysis using K-means and naïve bayes algorithm', Proceedings - 2018 2nd International Conference on Electrical Engineering and Informatics: Toward the Most Efficient Way of Making and Dealing with Future Electrical Power System and Big Data Analysis, ICon EEI 2018, no. October 2018, pp. 24–9.

#### Author Biographies



Manthrirathna M.A.L. is an undergraduate student reading for her Bachelor of Science degree specialised in

Computing and Information Systems under Faculty of Applied Sciences, Sabaragamuwa University of Sri Lanka. Data science and applications of machine learning are her main research interests.



Dr. R. M. Kapila Tharanga Rathnayaka is presently working as a Senior Lecturer in Statistics, Faculty of Applied Sciences, Sabaragamuwa University of Sri Lanka. He is highly interested in doing research in the fields of Financial Mathematics, Time series Modelling and Data Mining approaches.



Tharika Weerakoon obtained her Bachelor of Science degree specialised in computer science and technology from Faculty of Applied Sciences, Sabaragamuwa University of Sri Lanka. She is interested in research fields of data science, machine learning and has conducted interdisciplinary researches in business domain.

## An Alternative Approach to Authenticate Subflows of Multipath Transmission Control Protocol using an Application Level Key

Tharindu Wijethilake#, Kasun Gunawardana, Chamath Keppitiyagama and Kasun de Zoyza

*University of Colombo School of Computing, Sri Lanka*

#tnb@ucsc.cmb.ac.lk

**Abstract:** Multipath Transmission Control Protocol (MPTCP) is an extension to Transmission Control Protocol (TCP) proposed by the Internet Engineering Task Force (IETF). The intention of MPTCP was to use multiple network interfaces in a single network connection simultaneously. Researches have identified that there are a considerable amount of security threats related to the connections initiated by MPTCP. In this research, we studied on the security threats generated by sharing authentication keys in the initial handshake of the MPTCP in plain text format and investigated the applicability of external keys in authenticating sub-flows with minimum modifications to the kernel and the socket APIs. To pass external keys from user space to kernel space, we used `sin_zero` padding in TCP socket data structure. Through the experiments we found that MPTCP sub-flows can be authenticated and certain vulnerabilities can be avoided with our approach.

**Key Words:** MPTCP, Computer networks, Linux kernel, Authentication keys

### Introduction

TCP, the Transmission control protocol is one of the major protocols in the transport layer which was introduced in 1981 (Postel, 1981). The main objective of the TCP was to achieve the reliability of the communication channel between two hosts over a packet switching network. With the advancement of the technology, most of the modern devices such as laptops, mobile phones, and tablet PCs are having more than one network

interface, such that Ethernet port, WiFi, cellular data connection like 4G/LTE and so on. However, most of the time these devices use only one network interface at any given time, and hence, researchers investigated the plausibility of employing the second network interface in order to increase the throughput and to provide redundant connectivity. To achieve this, an extension to classical TCP was introduced as Multipath TCP (MPTCP) in 2013 (Ford, Raiciu, Handley and Bonaventure, 2013).

### A. Multipath TCP

Currently, Multipath TCP kernel is available for Linux operating systems, macOS, Android, and Apple iOS which can be installed separately. According to our knowledge, only Apple iOS has implemented MPTCP on their Siri voice assistant application (Bonaventure, 2014). Multipath TCP uses the normal TCP threeway handshake method to create the connections between two hosts. It does not change the currently available TCP protocol stack and the header format. All the data related to MPTCP are sent by using the TCP "option" field available in the TCP header.

To initiate the MPTCP connection between a client and the server, the client sends the normal TCP SYN message with the `MP_CAPABLE` options included in the TCP header. If the server is also configured with MPTCP, it will reply to the client using SYN/ACK with `MP_CAPABLE`. And finally, the connection is established with the ACK message from the client. In MPTCP these connections are known as subflows. To

initiate an additional subflow, it has to send another SYN packet to the server with MP\_JOIN option from the second network interface as shown in Figure 1.

When sending the SYN+MP\_CAPABLE message at the beginning, the client sends a key to the server in plain text, as the key of the client. The server also sends a key with the SYN/ACK+MP\_CAPABLE message in plain text as the key of the server. Finally, with the ACK message, the client sends both the keys to the server to confirm the connection. These shared keys are used to generate the HMAC, which will be later used to authenticate the new sub-flows that would be initialized between the two nodes (Demaria, 2016). In any case, if one of the hosts is not configured with MPTCP, it will automatically change into the normal TCP connection. So MPTCP is designed to be backward compatible and independent from the applications which are being executed on the server.

If a client needs to create a new sub-flow with the server, it will send a TCP SYN message to the server with the MP\_JOIN option using the client's second interface. In this case, the client sends a token to the server to authenticate itself. This token is a part of the HMAC generated by using the keys shared in the initial key exchange. After sharing the HMACs of keys between the client and the server, MPTCP will create a new sub-flow between them as shown in Figure 1. Other than that there is an option called ADD\_ADDR in MPTCP which can be used to advertise the available interfaces of a host to other hosts.

**B. The Goal**

There are several security vulnerabilities related to MPTCP connections. One of the major vulnerabilities is exchanging the key in plain text. A number of solutions has been proposed by IEFT for this problem. Some of the solutions were developed based on the ideas proposed in the RFC7430 (Bagnulo et

al., 2015) and some are developed by combining available security protocols.

Other than that, Paasch and Bonaventure, 2013 have proposed a different approach where it uses external keys in authenticating sub-flows. However, to implement that, the existing socket API has to be modified. Changing the existing socket API must be a prudent and meticulous effort as it requires a comprehensive restructuring of the current implementation of the TCP. Therefore, in this study, our goal is to explore an alternative approach to use external keys in authenticating subflows without modifying the existing socket API.

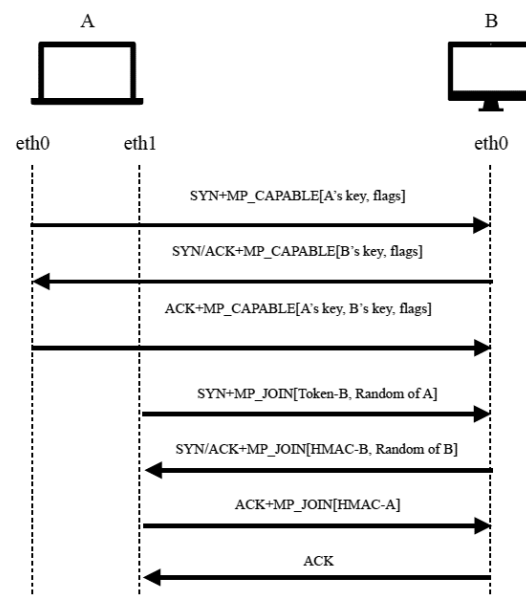

Figure 1: MP\_CAPABLE option and MP\_JOIN option

**Background and Literature Review**

Two of the key benefits of MPTCP mentioned in the RFC 6182 (Ford et al., 2011) are, to increase the ability to recover the connectivity in a connection failure without failing the end hosts by using multiple paths and to increase the efficiency of the connections by using multiple paths.

Creating multiple sub-flows between two hosts requires the authentication of one host to the other. As mentioned in the section I, the authentication mechanism (Ford, Raiciu, Handley and Bonaventure, 2013) employs plain text key exchange between two hosts



over a public network, which opens to many security risks. If an attacker got access to these keys, the attacker can create a new sub-flow with the server and even can remove the connection between with the legitimate client and the server (Bagnulo, 2011).

#### A. Security Threats

The attackers in the context of MPTCP can be categorized based on their location and their actions (Bagnulo et al., 2015). The attacker based on their location can be classify into three. Those are, off the path attackers, partial time on path attackers and on path attackers. Off path attacker is an attacker who is not in the middle of the path of MPTCP connection. Therefore, an off path attacker cannot eavesdrop the packets exchanged in the connection. The second group of attackers is the partial time on path attackers, who have access to the MPTCP connection, but not for the entire period of the connection. The third attacker is, on path attackers, who are on the MPTCP connection itself. That means they have access to one of the subflows of the connection (Bagnulo et al., 2015).

The attackers based on their actions can be classified in to two, which are eavesdropper and active attackers. Eavesdroppers collect data from the connection while the active attackers try to change the data on the connection (Bagnulo et al., 2015).

Bagnulo et al., (2015), have explicitly identified several security threats on MPTCP connections. The first security threat is ADD\_ADDER attack which is a man in the middle attack where the attacker can hijack the MPTCP session. The next attack is the DoS attack on MP\_JOIN which the attacker sends SYN+MP\_JOIN packets to a host with a valid token, then the host will open a connection. There is a maximum number of half open connections can be maintained by a host according to the implementation. When that

number is exceeded, the host becomes exhausted.

SYN flooding amplification is a denial of service attack (Eddy, 2017). The attackers send several SYN packets to a port and this make a number of half open connections which will eventually exhaust the connection.

Eavesdropper in initial key exchange is one of the main security issues in MPTCP. In this attack, the attacker collects the keys by listening to the initial key exchange and after that, the attacker can create new subflows using the captured keys (Bagnulo, 2011).

#### B. Current Status

For the identified security threats, several high-level solutions have been proposed in RFC 7430 (Bagnulo et al., 2015). Some of the researches based on these are as below.

1) Asymmetric key exchange: Without using plain text keys as in the original MPTCP, Kim and Choi, (2016) have proposed to use the Elliptic curve Diffie-Helman key exchange (Blake-Wilson et al., 2006) in the initial key exchange of MPTCP.

2) MPTCPsec: MPTCP secure (MPTCPsec) was proposed to satisfy two main objectives, which are detecting and recovering from packet injection attacks and to protect application level data (Jadin, Tihon, Pereira and Bonaventure, 2017).

3) ADD\_ADDR2: To overcome the vulnerability in ADD\_ADDR, the ADD\_ADDR2 option (Demaria, 2016) was proposed.

4) Using external keys to secure MPTCP: Exchanging keys in plain text is one of the main security issues in MPTCP. One of the solutions was proposed for this problem was to use external keys such as SSL or TLS keys to authenticate the MPTCP connection. These SSL or TLS keys are already negotiated in the application layer. The proposed solution (Paasch and Bonaventure, 2013) has suggested a mechanism to transfer the

application layer keys to the MPTCP layer by using two socket options. One is MPTCP\_ENABLE\_APP\_KEY, which is used to inform the MPTCP protocol that the application level keys are used to authenticate the connection, and MPTCP\_KEY is used to provide the application level key to the MPTCP layer.

Apart from the aforementioned research work, several other attempts are also available in literature. Using hash chains (Díez, Bagnulo, Valera and Vidal, 2020), using SSL (Paasch and Bonaventure, 2013) and tcpcrypt (Bittau et al., 2018) are some of such work.

The research work presented in this paper was inspired by the idea suggested by Paasch and Bonaventure, (2013). In their proposal, they have suggested employing external keys to authenticate the subflows of MPTCP such that external keys are taken from the application layer and transferred to the kernel level. In order to achieve that, they have suggested to include two new socket options, in turn modifies the existing socket API. In this research, our goal is to explore an alternative mechanism to achieve the same objective as (Paasch and Bonaventure, 2013) without altering the existing socket API.

## Methodology

As explained in section II, our goal is to obtain key information from the application level and deliver it to the kernel level without introducing new socket options. These key information is used to authenticate the subflows generated by the MPTCP protocol. In the first sub-flow, MPTCP uses MP\_CAPABLE option to check whether both the hosts are compatible with MPTCP and share the keys which are need to authenticate the next subflows. From the second subflow onwards MPTCP uses MP\_JOIN option to authenticate and join the new subflow to the same connection.

In this work, there are two assumptions to be made as given below.

- Both the hosts have to be agreed on the external keys before initiating the second subflow.
- The external keys have to be secure.

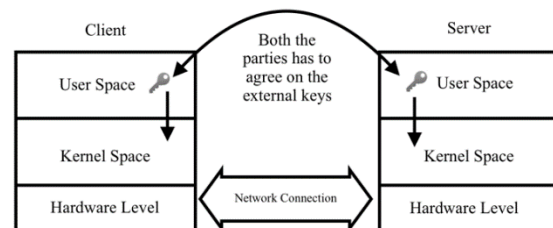

Figure 2. Kernel level, User level and External keys

Figure 2 shows the abstract picture of the solution proposed by this research. The external key means the shared secret between two hosts which was obtained from the application level. As shown in Figure 2, this key has to be transferred from the application level to the kernel level. After that, the key has to be used in the kernel level to authenticate the subflows. When the external key is available in the kernel level, it can be used to generate the authenticating material. The authenticating material has to be transferred to the server end for the authentication of the newly generated subflow.

### A. Transfer application level information to kernel level

To transfer application level key to the kernel level, several avenues were explored.

1) Using the proc file system: Proc is a pseudo file system in the Linux operating systems that can be accessed from /proc (proc(5) - Linux manual page, 2020). This is an interface to the kernel data structure and most of the files in the proc directory are read-only. Some of them are writable and can be used to modify kernel variables. With this approach, a new proc directory has to be created in the /proc directory and the key value has to be written in the newly created proc directory. Then this value has to be

accessed by the kernel file. There were several overheads were identified when incorporating proc file system to transfer application level information to the kernel level. One of the issues is, the key value from the application level has to be written to a file in a /proc directly before invoking a TCP socket. That is an overhead for the normal procedure of invoking TCP socket. The other issue is, the value in the proc file has to be read by the kernel using a function and then assigned to the kernel variable. It cannot be directly assigning to the kernel variable value by the proc file system itself. Therefore when the kernel initiating a TCP connection, it has to read proc files and assign the values to the kernel variables.

2) Netlink Sockets: Netlink (netlink(7) - Linux manual page, 2020) is a Linux kernel interface which can be used to communicate between kernel space and the user space, and between different user processes also.

3) Using sin\_zero of TCP socket : sin\_zero is a char array in the sockaddr in data structure used in TCP sockets. This data structure contains the necessary information to create a TCP connection between two hosts. Protocol, port number, and address are some of the information contain in the sockaddr in data structure. Other than that there is another char array called sin\_zero which is used as padding (struct sockaddr\_in, struct in\_addr, 2020). This space is not used by the sockets when creating connections. Therefore, theoretically, this space can be used to transfer data from user space to the kernel space, if it is not dropped when the information is transferred from user space to kernel space. This was further explored to identify the behavior of the sin\_zero variable and tracked the functions which transfer the data from user space to kernel space. Compared to other solutions, using the sin\_zero easier to send data from the application level. Char value can be easily copied to the sin\_zero character array when

creating the TCP socket. Therefore no need to customize the socket APIs. But the challenge was to retrieve the data from the kernel level. Theoretically, the sin\_zero data should be received by the kernel space, if it was not dropped by the system calls. We have used inet functions of af\_inet.c to retrieve the data from the sin\_zero in the kernel level. Implementation was straight forward when using the inet functions of af\_inet.c. Therefore the necessary functions were identified and modified to retrieve the data from sin\_zero. Key value send from the application level was directly assigned to a kernel variable with this method.

## B. Backward Compatibility

The backward compatibility is one of the important features in MPTCP. This means if the host machines are not compatible with MPTCP, it will automatically change into the original TCP connection. Therefore these solutions also should be backward compatible. This means if any of the machines are not configured with the proposed solution, it should use the normal MPTCP authentication mechanism.

To achieve this requirement, slight modifications to the code has to be done. It has to check whether the sin zero value is set from the user level or not. If the value is set, it has to use to the proposed solution, and if not it has to use the original MPTCP authentication mechanism.

## C. Key Transferring Mechanism

The userspace key was transferred to the kernel space by using the sin\_zero character array of the sockaddr in data structure of TCP socket and the data was obtained by the kernel space using inet functions of at inet.c with minimum modifications to the existing kernel implementations. Figure 3 shows the key transferring mechanism.

## Evaluation and Results

For the evaluation, the modified MPTCP kernel was installed on Ubuntu 16.04 LTS and several experiments were done. All these experiments were conducted in virtual environment.

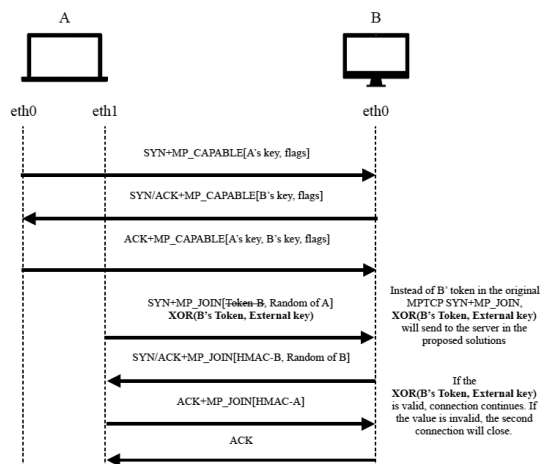

Figure 3: Key Transferring Mechanism

### A. Experimental Setup

TCP client and server sockets were implemented using the C programming language and executed on two virtual machines connected via the virtual network of Virtual box. The server is sending a string of data to the client and the client display that information in the terminal. Network packets were captured in the server machine and were analyzed using Wireshark.

In order to prove the concept of authenticating newly generated subflows using external keys, the authentication material was generated by XORing the token value generated by MPTCP and the external key that has obtained from the application level. This authentication material was sent to the server using the available token space in the SYN+MP\_JOIN packet and the authentication material was validated in the server end.

### B. Evaluation

To evaluate the proposed solution three main experiments were designed as below.

In the first experiment, it has to check whether the connection establishes when both ends use the same key. In this case, latter sub-flows should be authenticated, and data should be transmitted through all the sub-flows.

In the second experiment, it has to use different keys in both ends and check whether latter sub-flows establish or not. Since the keys are not identical, in this experiment, latter sub-flows should not be authenticated. Hence, it is expected to have only the first sub-flow of the connection.

Finally, it has to check whether the solution is backward compatible when `sin_zero` is not assigned any value. In that case, it is expected to use the original MPTCP authentication mechanism and establish the connections.

### C. Results

The experiments were conducted as mention in the above section and the results are as follows.

1) Using the same key on both server end and client end:

As mentioned in the experiment 1, when using the same key on both the server and the client ends, the MPTCP connection should start properly. It has to authenticate the second sub-flow using the key obtain from the application level and should start the second sub-flow. The connection was established using TCP sockets from both the server and the client machines. Figure 4 shows the packets send from interface eth0 of the client and Figure 5 shows the packets send from interface eth1 of the client. By analyzing the packets, it can come to a conclusion that both the interfaces has successfully completed the TCP three-way handshake and established the MPTCP

connection on both the interfaces successfully.

No.	Time	Source	Destination	Protocol	Length	Info
1	0.000000000	192.168.1.200	192.168.1.10	MPTCP	64	41962 - 5000 [SYN] Seq=0 Win=0 Len=0
2	0.000000000	192.168.1.10	192.168.1.200	MPTCP	84	5000 - 41962 [ACK] Seq=1448 Win=0
3	0.000000000	192.168.1.200	192.168.1.10	MPTCP	84	41962 - 5000 [ACK] Seq=1448 Win=0

Figure 4: Packets captured from eth0 interface

No.	Time	Source	Destination	Protocol	Length	Info
1	0.000000000	192.168.1.200	224.0.0.251	MDNS	87	Standard query 0x6688 PTR ipps. tcp. loc...
2	0.000000000	192.168.1.200	192.168.1.200	MPTCP	84	5000 - 41962 [SYN] Seq=0 Win=0 Len=0
3	0.000000000	192.168.1.10	192.168.1.200	MPTCP	84	41962 - 5000 [ACK] Seq=1448 Win=0

Figure 5: Packets captured from eth1 interface

2) Using the different keys on server end and client end:

As explained in the experiment 2, two different keys were used in server end and client end when starting the sockets, and the Figure 6 shows the captured and filtered packets send from the client's eth0 interface. Figure 7 shows the packets sent from the eth1 interface of the client.

According to the captured packets, it is clear that the first connection was successfully established with the server because the TCP three ways handshake was successfully completed. But when observing Figure 7, it is clear that the TCP three ways handshake has stopped at the SYN ACK stage. Protocol fails to complete the authentication process because of having two different keys in the server end and the client end. Therefore, it has dropped the connection. Which means that a malicious party attempting to join without having the shared application key, it cannot create the latter sub-flows.

No.	Time	Source	Destination	Protocol	Length	Info
69	0.01128920	192.168.1.100	192.168.1.10	MPTCP	64	38317 - 5000 [SYN] Seq=0 Win=0 Len=0
70	0.012847783	192.168.1.100	192.168.1.10	MPTCP	84	5000 - 38317 [ACK] Seq=1448 Win=0
71	0.012899989	192.168.1.10	192.168.1.100	MPTCP	74	[TCP Window Update] 5000 - 38317 [ACK]

Figure 6: Packets captured from eth0 interface

No.	Time	Source	Destination	Protocol	Length	Info
2	0.011584585	192.168.1.100	224.0.0.251	MDNS	87	Standard query 0x0000 PTR ipps. tcp. loc...
3	0.000000000	192.168.1.100	192.168.1.100	MPTCP	84	41962 - 5000 [SYN] Seq=0 Win=0 Len=0
4	0.01192100	192.168.1.10	192.168.1.100	TCP	54	5000 - 41962 [RST] Seq=1448 Win=0

Figure 7: Packets captured from eth1 interface

Therefore the main goal of the research was successfully achieved. This means without having the correct application level

information, the second subflow cannot be initiated.

3) Backward compatibility: As explained in experiment 3, the sockets have set without assigning any value to `sin_zero` variable. Figure 8 shows the packets captured on both the eth0 and eth1 interfaces of the client and it has successfully established the MPTCP connection. Which shows that it has used normal MPTCP. Therefore the solution is backward compatible if both the client and server does not use application level keys to authenticate the sub-flows.

### Conclusion and Future Work

Use of external keys in authentication was proposed by C. Paasch and O. Bonaventure (Bagnulo et al., 2015) where they propose to modify existing Socket API. Since it is a redesign and a major restructuring to current implementation, we explored an alternative approach to authenticate sub-flows of MPTCP connection using external keys.

In this study, we experimented the completeness of our approach in three facets. First, with a common external key, two parties were able to authenticate and establish sub-flows successfully. Second, it was shown that a party that does not possess the common external key could not establish a sub-flow due to failed authentication. Finally, when an external key is not involved, the method returns to the normal MPTCP authentication, and hence our approach is backward compatible. With these three facets, we have demonstrated the completeness of the proposed approach. Therefore, it can be used to authenticate sub-flows and eliminate the vulnerabilities in classical MPTCP to certain extent.

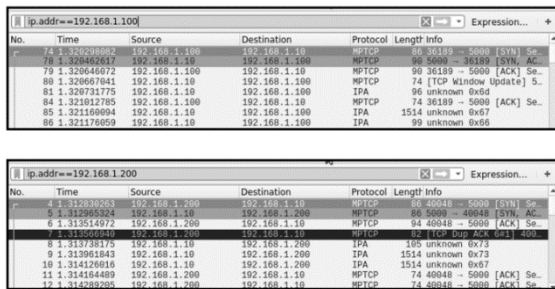

No.	Time	Source	Destination	Protocol	Length	Info
74	1.320246052	192.168.1.100	192.168.1.10	MPTCP	66	36189 - 5000 [SYN] Seq=...
75	1.320446047	192.168.1.10	192.168.1.100	MPTCP	96	5000 - 36189 [SYN, ACK] Seq=...
79	1.320646072	192.168.1.100	192.168.1.10	MPTCP	90	36189 - 5000 [ACK] Seq=...
80	1.320697041	192.168.1.100	192.168.1.100	MPTCP	74	[TCP Window Update] Seq=...
81	1.320731775	192.168.1.10	192.168.1.100	TPA	96	unknown 6x66
84	1.321012785	192.168.1.100	192.168.1.10	MPTCP	74	36189 - 5000 [ACK] Seq=...
85	1.321090994	192.168.1.10	192.168.1.100	TPA	1514	unknown 6x67
88	1.321170659	192.168.1.10	192.168.1.100	TPA	96	unknown 6x66

No.	Time	Source	Destination	Protocol	Length	Info
4	1.312933223	192.168.1.100	192.168.1.10	MPTCP	66	5000 - 5000 [SYN] Seq=...
5	1.312955324	192.168.1.10	192.168.1.200	MPTCP	66	5000 - 46048 [SYN, ACK] Seq=...
6	1.3129514972	192.168.1.200	192.168.1.10	MPTCP	94	46048 - 5000 [ACK] Seq=...
7	1.312955324	192.168.1.100	192.168.1.10	MPTCP	74	[TCP Window Update] Seq=...
8	1.313738175	192.168.1.10	192.168.1.200	TPA	105	unknown 6x73
9	1.313951043	192.168.1.10	192.168.1.200	TPA	1514	unknown 6x73
10	1.314126016	192.168.1.10	192.168.1.200	TPA	1514	unknown 6x67
11	1.314164489	192.168.1.200	192.168.1.10	MPTCP	74	46048 - 5000 [ACK] Seq=...
12	1.314263206	192.168.1.200	192.168.1.10	MPTCP	74	46048 - 5000 [ACK] Seq=...

Figure 8: Packets captured from eth0 and eth1 interfaces with no key

As for future work, it has to develop a mechanism to generate a secure authentication material and proper method to transfer the authentication material from the client machine to the server machine.

### References

Postel, J., 1981. RFC 793 - Transmission Control Protocol. [online] Tools.ietf.org. Available at: <<https://tools.ietf.org/html/rfc793>> [Accessed 26 June 2019].

Ford, A., Raiciu, C., Handley, M. and Bonaventure, O., 2013. RFC 6824 - TCP Extensions For Multipath Operation With Multiple Addresses. [online] Tools.ietf.org. Available at: <<https://tools.ietf.org/html/rfc6824>> [Accessed 26 June 2019].

Bonaventure, O., 2014. Observing Siri : The Three-Way Handshake — MPTCP. [online] Blog.multipath-tcp.org. Available at: <[http://blog.multipath-tcp.org/blog/html/2014/02/24/observing\\_siri.html](http://blog.multipath-tcp.org/blog/html/2014/02/24/observing_siri.html)> [Accessed 27 June 2019].

Demaria, F., 2016. Security Evaluation Of Multipath TCP. [online] Diva-portal.org. Available at: <<http://www.diva-portal.org/smash/get/diva2:934158/FULLTEXT01.pdf>> [Accessed 27 June 2019].

Ford, A., Raiciu, C., Handley, M., Barre, S. and Iyengar, J., 2011. Architectural Guidelines For Multipath TCP Development. [online] Rfc-editor.org. Available at: <<https://www.rfc-editor.org/info/rfc6182>> [Accessed 27 June 2019].

Bagnulo, M., 2011. RFC 6181 - Threat Analysis For TCP Extensions For Multipath Operation With Multiple Addresses. [online] Tools.ietf.org.

Available at: <<https://tools.ietf.org/html/rfc6181>> [Accessed 30 June 2019].

Bagnulo, M., Paasch, C., Gont, F., Bonaventure, O. and Raiciu, C., 2015. Analysis Of Residual Threats And Possible Fixes For Multipath TCP (MPTCP). [online] Rfc-editor.org. Available at: <<https://www.rfc-editor.org/info/rfc7430>> [Accessed 30 June 2019].

Jadin, M., Tihon, G., Pereira, O. and Bonaventure, O., 2017. Securing Multipath TCP: Design & Implementation. [online] Dial.uclouvain.be. Available at: <<https://dial.uclouvain.be/pr/boreal/object/boreal:184252>> [Accessed 30 June 2019].

Paasch, C. and Bonaventure, O., 2013. Securing The Multipath TCP Handshake With External Keys. [online] Tools.ietf.org. Available at: <<https://tools.ietf.org/id/draft-paasch-mptcp-ssl-00.html>> [Accessed 30 June 2019].

Díez, J., Bagnulo, M., Valera, F. and Vidal, I., 2020. Security For Multipath TCP: A Constructive Approach.

Kim, Y. and Choi, K., 2016. Draft-Kim-Mptcp-Semtpcp-00. [online] Datatracker.ietf.org. Available at: <<https://datatracker.ietf.org/doc/html/draft-kim-mptcp-semtpcp>> [Accessed 30 June 2019].

Blake-Wilson, S., Bolyard, N., Gupta, V., Hawk, C. and Moeller, B., 2006. RFC 4492 - Elliptic Curve Cryptography (ECC) Cipher Suites For Transport Layer Security (TLS). [online] Tools.ietf.org. Available at: <<https://tools.ietf.org/html/rfc4492>> [Accessed 5 July 2019].

McGrew, D., 2008. RFC 5116 - An Interface And Algorithms For Authenticated Encryption. [online] Datatracker.ietf.org. Available at: <<https://datatracker.ietf.org/doc/rfc5116/>> [Accessed 5 July 2019].

Eddy, W., 2017. RFC 4987 - TCP SYN Flooding Attacks And Common Mitigations. [online] Tools.ietf.org. Available at: <<https://tools.ietf.org/html/rfc4987>> [Accessed 5 July 2019].

Bittau, A., Giffin, D., Handley, M., Mazieres, D., Slack, Q. and Smith, E., 2018. Draft-Ietf-Tcpinc-Tcpcrypt-10 - Cryptographic Protection Of TCP Streams (Tcpcrypt). [online] Datatracker.ietf.org. Available at:

<<https://datatracker.ietf.org/doc/draft-ietf-tcpinc-tcpencrypt/10/>> [Accessed 5 July 2019].

Bittau, A., Giffin, D., Handley, M., Mazieres, D. and Smith, E., 2017. Draft-Ietf-Tcpinc-Tcpno-18 - TCP-ENO: Encryption Negotiation Option. [online] Tools.ietf.org. Available at: <<https://tools.ietf.org/html/draft-ietf-tcpinc-tcpno-18>> [Accessed 5 July 2019].

Dierks, T. and Rescorla, E., 2018. RFC 5246 - The Transport Layer Security (TLS) Protocol Version 1.2. [online] Tools.ietf.org. Available at: <<https://tools.ietf.org/html/rfc5246>> [Accessed 5 July 2019].

Wireshark.org. 2020. Wireshark · Go Deep.. [online] Available at: <<https://www.wireshark.org>> [Accessed 20 July 2019].

Man7.org. 2020. Proc(5) - Linux Manual Page. [online] Available at: <<http://man7.org/linux/man-pages/man5/proc.5.html>> [Accessed 8 July 2019].

Man7.org. 2020. Netlink(7) - Linux Manual Page. [online] Available at: <<http://man7.org/linux/man-pages/man7/netlink.7.html>> [Accessed 8 July 2019].

Gta.ufrj.br. 2020. Struct Sockaddr\_In, Struct In\_Addr. [online] Available at: <[https://www.gta.ufrj.br/ensino/eel878/sockets/sockaddr\\_inman.html](https://www.gta.ufrj.br/ensino/eel878/sockets/sockaddr_inman.html)> [Accessed 10 July 2019].

## Author Biographies

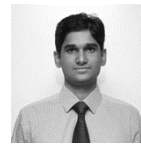

Tharindu Wijethilake is an assistant lecturer at the University of Colombo School of Computing. He obtained Master's degree in Computer Science from the UCSC. His research interests include computer networks, network security and information system security.



Kasun Gunawardana is a senior lecture at the University of Colombo School of Computing. He obtained his PhD from the Monash University. His research interests are Machine Learning, Cyber Security, and Digital Forensics.



Chamath Keppitiagama obtained his PhD from the University of British Columbia and he is a senior lecturer at the University of Colombo School of Computing. His research interests are is Computer Networks, Distributed Systems and Operating Systems.



Kasun de Zoysa is a senior lecturer at the University of Colomobo School of Computing. He obtained his Phd from the Stockholm His research interests includes Information Security, Sensor Networks and Embedded Systems.

## An Ontology-Based Data Mining Approach for Predicting the Research Ideas using Past Research in the Wildlife Sector of Sri Lanka

P Premisha<sup>1#</sup>, BTGS Kumara<sup>2</sup>, EP Kudavidanage<sup>3</sup>, and K Banujan<sup>4</sup>,

<sup>1,2,4</sup>*Department of Computing & Information Systems, Faculty of Applied Sciences, Sabaragamuwa University of Sri Lanka*

<sup>3</sup>*Department of Natural Resources, Faculty of Applied Sciences, Sabaragamuwa University of Sri Lanka*  
#ppremisha@std.appsc.sab.ac.lk

**Abstract:** Sri Lanka being a global biodiversity hotspot, places great value for biodiversity owing to ecological, socio-economic, and cultural factors. However, the wildlife of Sri Lanka is critically threatened due to several factors, mainly human activities and needs dire conservation measures. Inadequate knowledge and technical support also hinder wildlife management activities. Findings of wildlife research studies could be integrated into data-driven conservation and management decisions but the current contribution is not satisfactory. This research work shows a novel data mining approach for finding hidden keywords and automatic labelling for past research work in this domain. We used Latent Dirichlet Allocation (LDA) algorithms to model topics and identify the major keywords also developed an ontology model to represent the relationships between each keyword. Both approaches are also useful for potential research ideas, to identify research gaps and can classify the subjects related to a publication by non-professional related fields. The experiment results demonstrate the validity and efficiency of the proposed method.

**Key Words:** wildlife, LDA, ontology, topic modelling

### Introduction

Wildlife is critical for the sustenance of life on earth. Conserving biodiversity is critical to

maintaining a healthy ecological balance in the world.

Sri Lanka is a global biodiversity hotspot consisting of a large variety of fauna and flora. It is one of the main sources of income generation through tourism and other means. The diversity of ecosystems is primarily due to its topographical and climatic heterogeneity, as well as its coastal effect (L.P.Jayatissa, 2012). This rich biodiversity is threatened due to unplanned land use, pollution, overexploitation, etc.

Data from wildlife research can contribute to a large extent is proper conservation and management. However, there is a gap between research and application. Most of the existing research work is not converted into applications while there are many data gaps. Limited numbers of researchers are focussing on the actual research needs from conservation. The selection of research topics is often not compatible with the actual research needs due to multiple reasons. This is a disheartening scenario as there are plenty of opportunities for such work. Inadequate knowledge of the existing research and their applicability, inadequate use of technology, and inability to locate some research are some of the contributing factors. Other than the research published in a known journal, some past research information available online cannot be found properly because they belong to conventional archives, unfortunately.



Increasing public awareness on the values of wildlife and the consequences of losing this heritage can assist conservation to a large extent. To achieve this, we have to simplify the gap between the public and the accessibility to information on wildlife. Technology can play a major role in filling the gap between them.

Mostly wildlife studies aimed to understand species diversity, behaviour, and habitat use, and ecology, the role of wildlife in disease transmission, species conservation, population management, and methods to control threats to diversity.

In our study, we concentrate on reviewing past research papers using data mining techniques to provide potential research ideas that can be conducted in the future. To fill the data needs for conservation our solution focuses primarily on semi-automating the finding of research gaps through abstract analysis. Finally, the model includes the most commonly used keywords and question top. This will be a vital milestone for researches as well as wildlife activists to give an eye on recent problems that need a solution urgently.

In technological perspective there was prior work (Zhu, Klabjan and Bless, 2017)(Adhitama, Kusumaningrum, and Gernowo, 2018)(Chowdhury and Zhu, 2019) has shown hierarchical relationship-based latent Dirichlet allocation (hrLDA), a data-driven model of hierarchical topics to derive terminology ontology from a large number of heterogeneous documents. Unlike conventional topic models, hrLDA relies on noun phrases

instead of unigrams, considers syntax and text structures, and enriches topic hierarchies with topic relations. Through a series of experiments, we are demonstrating hrLDA's superiority over established topic models, particularly for hierarchy building.

So we have to deviate past research techniques to come up with our final solution. Some trending techniques used here to improve the outputs. Our research aims to resolve the inadequate application of wildlife research and technologies in the decision-making process.

### **Methodology**

In our research, we used a semi-automated methodology using LDA and Ontology. The text data of the defined domain were collected and pre-processed for the input to LDA algorithms then compared with the ontology graph to the final output. The steps of our methodology defined below.

#### **A. Data Collection**

We collected information about past wildlife researches in Sri Lanka from 2006-2019, with the aid of the Department of Natural Resources, Sabaragamuwa University of Sri Lanka, and an extreme literature survey. After that, we obtained full research papers of selected papers from each domain. We've selectively applied the title and abstract data to the CSV file from those research papers.

#### **B. Data Pre-processing**

Data pre-processing is so important because if our data set contained mistakes, redundancies, missing values, and inconsistencies that all compromised the integrity of the set, we need to fix all those issues for a more accurate

outcome (Editors, 2019). We performed the following steps:

- Tokenization: Divide the text into sentences, and the sentences into words. Lower case the words and smooth punctuation
- Stop word removal: Delete words that have fewer than 3 letters. All stop words are removed.

- Lemmatizing: Words in the third person are shifted to first-person and verbs shifted to present from past and future tenses.
- Words are stemmed — words are reduced to their root form

### C. Topic Modelling-LDA

LDA helped rework the textual data into a format that could act as an input to the LDA model for training. We began by converting the documents to a simple representation of the vectors as a group of words called Bag of Words (BOW) (Rani, Dhar, and Vyas, 2017). First, we translated a list of titles into vector lists, all with vocabulary-capable lengths.

The topic model described in Figure 2 is one of the unsupervised methods; that is, it is a technique of text mining in which the topics or themes of documents can be extracted from a larger collected corpus of documents (Lee et al., 2018). LDA, one of the most popular modelling techniques, is a probabilistic model of a corpus-based on Bayesian models. This is often considered a probabilistic extension of Latent Semantic Analysis (LSA). The LDA's basic idea is that each document has a word distribution that can be defined as.

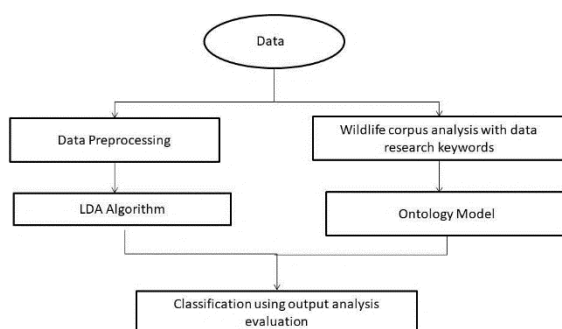

Figure 1: Methodological framework

### D. Ontology

Ontologies contain features such as general vocabulary, reusability, machine-readable content, as well as semantic searching, enabling agent interaction, and ordering and structuring information for the Semantic

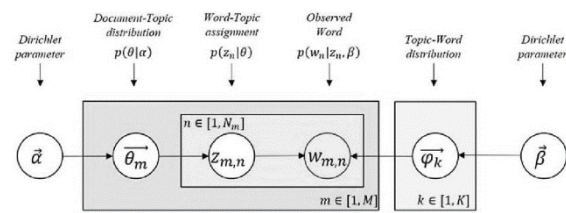

Figure 2: Graphical model for LDA

Web application (Movshovitz-Attias and Cohen, 2015). Automated learning is the issue in ontology engineering, such as the lack of a fully automated approach from a text corpus or dataset of different topics to form ontology using machine learning techniques is still present.

The ontology model was finalized using protégé tools, which is the most popular tool of ontology visualization (Hussein et al., 2020). The Protégé 5.5.0 tool is being applied for further development in various disciplines for a better understanding of knowledge with the aid of domain professionals in the wildlife.

### E. Comparison

Our interactive, web-based visualization framework, LDAvis, has two key functionalities that allow users to understand the topic-term relationships within a fitted LDA model, as well as several additional features that provide additional perspectives on the model (Adhitama, Kusumaningrum, and Gernowo, 2018). First and foremost, LDAvis allows one to pick a topic to report the words most applicable to the subject. We compared the total term frequency to the approximate term frequency for finding the keywords that appear and are most significant.

### F. Evaluation

In our research, the output assessment evaluation method was used to analyse the final output to the overall conclusion. We have defined a new approach to automatic ontology learning, and this method has applied the LDA model to generate topics, and the progress of learned ontology does

not need the seed of ontology, but only the document corpus (Lin, 2017).

## Results

The outcome of this paper was described by using abstract past researches that serve as an input in Sri Lanka. For

LDA implementation we used python language. The text used as input is interpreted and tokenized, resulting in a compilation of input nouns, adjectives, and verbs. Furthermore, it eliminates all the stop words like papers.

The tokenized and pruned text is then subjected to the LDA modelling algorithm. That gave production as word sets that could collection contain words that are linked to each other. Such collections of words are classified as various subjects. The LDA model approach is used to arrange, synthesize broad corpus, and to retrieve subjects and words.

Figure 3 and Figure 4 are the final visualizations of the LDA model which shows the overall keyword for each research paper and the essential keyword using the pyLDAvis library in python. This output allowed the detection of hidden keywords from every abstract. To get the output of the pyLDAvis method we used the equation of saliency and relevance to accommodate the keyword distributions.

The intertropical distance map is indicated via multidimensional scaling by our LDA output. In CE literature and inter-topic distance, the top 20 salient keywords.

$$Saliency = frequency \times [sum p(t|w) \times \log(p((t|w)/ p(t)))] \quad (1)$$

Where, t- Topic, Frequency (w) –frequency of word w, p (t|w) - conditional probability: the likelihood that observed word w was generated by latent topic t, p (t) - probability of topic t, sum p (t|w) - summation of the probability of observed word w was generated by latent topic t

This formulation (1) defines (in a theoretical context of information Sense) how informative the specific term w, versus a randomly selected word, is for determining the generating subject. For instance, if a word w appears in all topics, observing the word tells us nothing about the topical mixture of the document; thus the word will obtain a score of low distinctiveness. The saliency (Chuang, Manning and Heer, 2012) of a term is defined by the product:

Figure 3: LDA model for overall keyword

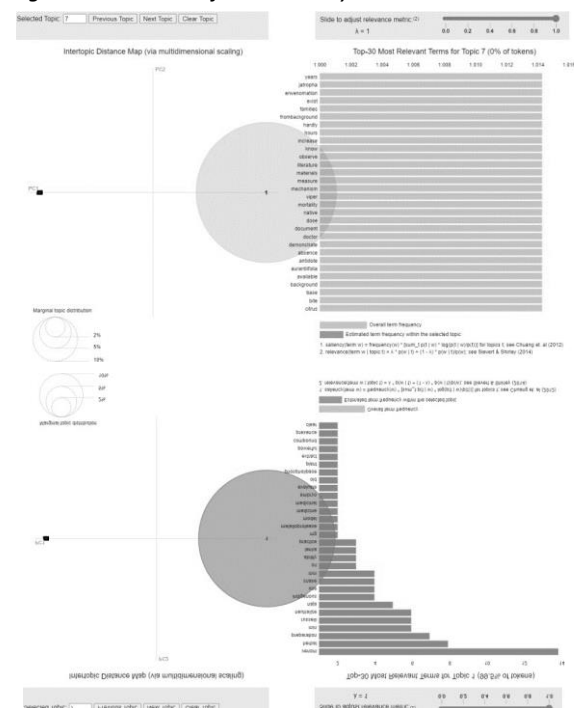

Figure 4: LDA model for estimated keyword

$$Relevance = \lambda * p(w|t) + (1 - \lambda) * p(w|t)/p(w) \quad (2)$$

Where,  $\lambda$  –slide to adjust relevant metric, p (w|t) - conditional probability: the likelihood that observed word w was generated by latent topic t, p (w) –probability of word w (Frasier et al., 2019)

Figure 5: Ontograph partial view

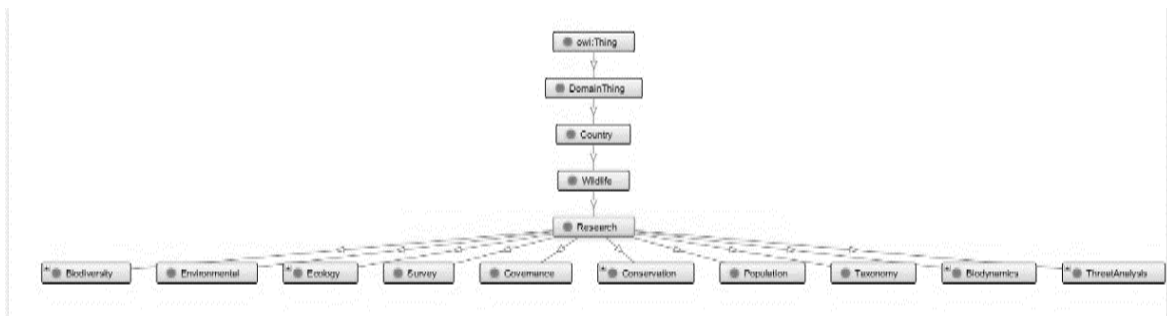
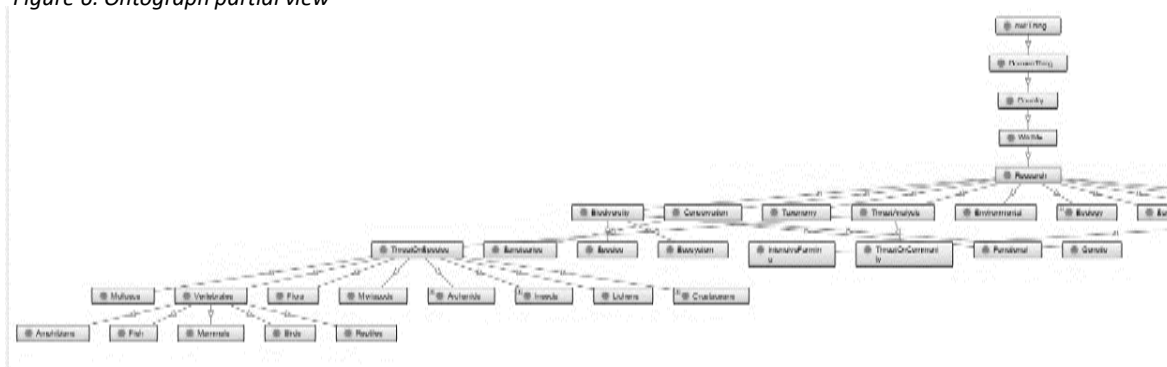

Figure 6: Ontograph partial view



Using this output from LDA we compared the ontology output. Analysed the estimated keywords and their ontology domain formation. The protégé tool used the Sri Lankan wildlife research domain ontology to be developed. The partial view of the final ontology production shown in Figures 5 and 6.

Each research papers' keyword generated by LDA visualization model estimation was analyzed through the ontograph and each paper classification performed.

### Conclusion and Discussion

In this paper, we suggested a domain-independent and self-learning model, which means that studying ontologies in new domains is very exciting and thus can save considerable time and effort in the acquisition of ontology. For past research papers using learning ontologies, we have established a new approach for automatic classification, and this method applied the LDA model to generate topics, and the progress of learned ontology does not need the seed of ontology, it only requires given document corpus. We generated LDA

keywords for selected research abstracts of the past wildlife domain in Sri Lanka. We devise a semiautomated topic labeling for the research papers. The final experiment has proved effective results.

This work reduced the complexity to label the research papers without any domain pre-knowledge. Using this method the hidden keyword and the relations between the keywords also identify to help future research ideas.

### Future Works

In this topic labelling method, there is some inefficient while ontology classification. Because there are several cross path hierarchy moves of keywords identified from LDA. So when we used ontology it collapsed the different path in onto graph. So we will use other classification methods for fully automated our methods.

### References

Adhitama, R., Kusumaningrum, R. and Gernowo, R. (2018) 'Topic labeling towards news document collection based on Latent Dirichlet Allocation and ontology', Proceedings - 2017 1st

International Conference on Informatics and Computational Sciences, ICICoS 2017, 2018-Janua, pp. 247–251. doi: 10.1109/ICICOS.2017.8276370.

Chowdhury, S. and Zhu, J. (2019) 'Towards the ontology development for smart transportation infrastructure planning via topic modeling', Proceedings of the 36th International Symposium on Automation and Robotics in Construction, ISARC 2019, (Isarc), pp. 507–514. doi: 10.22260/Isarc2019/0068.

Chuang, J., Manning, C. D. and Heer, J. (2012) 'Termite: Visualization techniques for assessing textual topic models', Proceedings of the Workshop on Advanced Visual Interfaces AVI, (June), pp. 74–77. doi: 10.1145/2254556.2254572.

Editors, N. T. R. (2019) Technologies in Data Science and Communication.

Frasier, T. R. et al. (2019) 'Bayesian abundance estimation from genetic mark-recapture data when not all sites are sampled: an example with the bowhead whale', bioRxiv. Elsevier Ltd, 22, p. 549394. doi: 10.1101/549394.

Hussein, G. et al. (2020) 'ONTOLOGY DOMAIN MODEL FOR E-TUTORING SYSTEM', 5(1), pp. 37–44.

L.P.Jayatissa (2012) Present Status of Mangroves in Sri Lanka, The National Red List 2012 of Sri Lanka; Conservation Status of the Fauna and Flora.

Lee, J. et al. (2018) 'Ensemble modeling for sustainable technology transfer', Sustainability (Switzerland), 10(7). doi: 10.3390/su10072278.

Lin, Z. (2017) 'Terminological ontology learning based on LDA', 2017 4th International Conference on Systems and Informatics, ICSAI 2017, 2018-Janua(Icsai), pp. 1598–1603. doi: 10.1109/ICSAI.2017.8248539.

Movshovitz-Attias, D. and Cohen, W. W. (2015) 'KB-LDA: Jointly learning a knowledge base of hierarchy, relations, and facts', ACL-IJCNLP 2015 - 53rd Annual Meeting of the Association for Computational Linguistics and the 7th International Joint Conference on Natural Language Processing of the Asian Federation of Natural Language Processing, Proceedings of the

Conference, 1, pp. 1449–1459. doi: 10.3115/v1/p15-1140.

Rani, M., Dhar, A. K. and Vyas, O. P. (2017) 'Semi-automatic terminology ontology learning based on topic modeling', Engineering Applications of Artificial Intelligence, 63(August), pp. 108–125. doi: 10.1016/j.engappai.2017.05.006.

Zhu, X., Klabjan, D. and Bless, P. N. (2017) 'Unsupervised terminological ontology learning based on hierarchical topic modeling', Proceedings - 2017 IEEE International Conference on Information Reuse and Integration, IRI 2017, 2017-Janua, pp. 32–41. doi: 10.1109/IRI.2017.18.

### Acknowledgement

We acknowledge the Department of wildlife conservation of Sri Lanka for the research permit (WL/3/2/60/15) granted to E. P. Kudavidanage.

### Author Biographies



Premisha Premananthan is an undergraduate student at the Sabaragamuwa University of Sri Lanka who follows a Bachelor of Science Special degree in Information Systems. She is currently in the final year of her degree program.



Banage T. G. S. Kumara received the Bachelor's degree in 2006 from Sabaragamuwa University of Sri Lanka. He received the master's degree in 2010 from the University of Peradeniya and a Ph.D. degree in 2015 from the University of Aizu, Japan. His research interests include semantic web, web data mining, web service discovery, and composition.



Enoka P. Kudavidanage received a Bachelor's degree in Zoology from the University of Colombo. She received a master's degree in Environmental Sciences from the

University of Colombo and a Ph.D. degree for Conservation Biology from the National University of Singapore.



Kuhaneswaran Banujan received his Bachelor of Science degree in 2019 with the Second Class Upper Division from Sabaragamuwa University of Sri Lanka.

He is currently attached to the Department of Computing and Information Systems as a Lecturer in Computer Science. His research interests include Data Mining, Knowledge Management, Ontology Modeling, and Business Process Simulation.

## Citizens Acceptance of Online Services in Sri Lanka Police: Study on Police Clearance Online System

HANK Damayantha Wijaya Sri

*DIG Office, Monaragala, Sri Lanka*

**Abstract:** The Police, as the main law enforcement agency in Sri Lanka, assure a society which is free from fear of crimes & violence by her vision statement. Ensuring the state security is vital because threat to the security is, undoubtedly, vulnerability for everything. The Police Clearance Certificate (PCC) is one of the proactive measures to assure the security and social tranquillity. PCC must be free from fraud and errors. The criticism towards issuing agency was to delay of processes, bureaucracy and corruption. In order to expedite the clearance process, in 2015, it was introduced a E-governance approach. The aim of this study was to evaluate the efficiency and effectiveness of this new on-line system and reviewing the level of customer satisfaction. This is the first and only research made on this new Police Clearance Certificate Issuing System (PCCIS) in Sri Lanka. The data in this qualitative research were gathered through questionnaires, interviews, literature survey and observations. The samples were selected in a manner which can be generalized the results to the whole population. Though the Sri Lanka Police (SLP) assure the issuing of PCC within 14 days, this research revealed that 58% of the applicants don't get it within that period. But it was revealed that the corruption and organizational bureaucracy have been remarkably reduced with the on-line mechanism. The attractiveness & user friendliness of the system is comparatively good. The recommendations, made by this study, will contribute for further enhancements. Unfortunately, majority of

the people in Sri Lanka are not conversant with available police on-line services. Same time, unavailability of National E-government Platform and Data Warehouse, connecting the public & private agencies, is a big imperfection in the country.

**Key Words:** E-governance, Police Clearance Certificate, Police Clearance Certificate Issuing System

### Introduction

The SLP ensure to maintain a peaceful environment to live with confidence without fear of crimes & violence by her vision statement. (SLP, 2018) PCC is one of proactive strategies used to achieve that vision. SLP with the support of Information and Communication Agency in Sri Lanka (ICTA) introduced the new Police Clearance Certificate Issuing System (PCCIS) in order to expedite the issuing process in 2015.

#### A. E-governance for Policing

Electronic governance is the application of information and communication technology (ICT) for delivering government services, exchange of information, communication of transactions, integration of various stand-alone systems and services. (Bose & Rashel, 2019) It improves the efficiency and effectiveness in the government service, reduce individual and government cost, reduce corruption, transform public administration from bureaucracy to service orientation, reach out to a broader part of population, improve the democratic process. (Kanchana & Samarakoon, 2018)

The Police organizations in the world has introduced numerous online services to their

citizens in order to improve the service efficiency. As an example, India Police has provided DIGITAL POLICE Portal as a platform for citizens to file crime related complains on- line and seek antecedent verification of prospective employees or tenants, PCC process etc. The Digital Police Portal in India is a smart policing initiative to provide a better service to the citizens and for efficient police investigations and preventive measures. (INDIA) (India) (INDIA) Singapore immensely applies online services in order to make Singapore the safest place in the world. On-line corridor is open for the public to check their eligibility for a certificate of merit, individual criminals' records, traffic offences records, warrants of arrest, driving license and demerit points, suspicious transactions, PCC etc. Most importantly Singapore police force values its clients' feedback for the system developments. (Singapore, 2018)

Establishing of ICTA in July 2003 is a milestone of information & communication technology in Sri Lanka. (GIC, 2007) According to the policy Statement of ICTA "All government organizations should ensure the availability and delivery of services through multiple electronical channels". (ICTA, 2015) Adhering to above policy, SLP with the guidance and support of ICTA initiated PCCIS in order to provide efficient service. Today it is been issued more than fifty thousand PCC, annually. New system could to resolve the prevailed issues like unattended applications in the queue, fraudulent document and frustrations. The new PCCIS is providing her service almost three years to date. Technologically advanced policing system undoubtedly enhance the customer satisfaction and service efficiency. This is the first and only systematic study done on PCCIS, ever.

#### B. Aim

The aim of this study is to evaluate the efficiency & effectiveness of newly

Introduced PCCIS and to identify the areas for system advancement.

#### C. Objectives

The objectives of the study are,

- 1) To check the efficiency level of the new PCCIS.
- 2) To test effects of PCCIS on organizational bureaucracy and corruption.
- 3) To explore new strategies to improve the current PCCIS.
- 4) To find the level of citizens' familiarity on PCCIS.

#### Research Methodology

An unreliable method produces unreliable results. And as the consequence of poor methodology, it undermines the value of the interpretation of findings. Hence the methodology of this study was carefully selected allowing the readers a critical evaluation and to ensure the study's overall validity and reliability.

#### A. Research questions

- 1) The researcher identified following questions in this study.
- 2) Whether the introduced on-line clearance certificate mechanism has succeeded enough to provide efficient and effective service to the applicants.
- 3) Whether this on-line clearance certificate system has supported to overcome the corruption and the bureaucracy in the police service.
- 4) Are there any new technologies, systems or processes which can be implemented in order to improve the efficiency of this on-line clearance system?
- 5) Whether the Sri Lankan citizens are conversant with the on-line services provided by SLP.



### B. Research Strategy

The strategy in this study was selected in order to provide an insight of the problem and appropriate solutions. Mainly this is a Qualitative study of subjective in nature. Quantitative research strategy also was used but comparatively low. The descriptive strategy was used only when describes a particular situations. The researcher did not manipulate any condition. It just observed already exists in the field & surrounding and it helped to uncover the hidden facts & figures of the study area.

### C. Data Collection Method and Tools

In this study it was collected both primary and secondary data using the the instruments of questionnaires,interviews, observations and literature survey as shown below

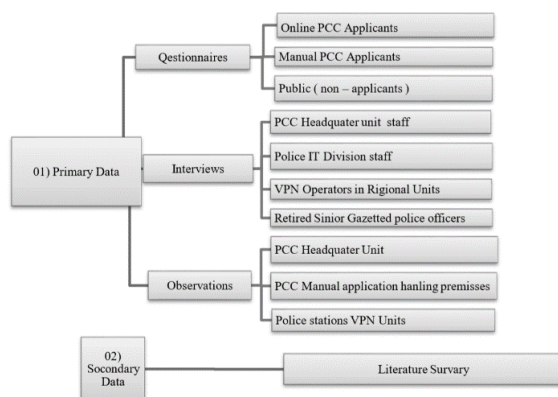

Figure 1: Data Collection Method and Tools  
 Source: By Researcher (2019)

1) Questionnaire: The questionnaires were properly constructed and responsibly administered. Number of key questions, direct and indirect, were asked from the participants in order to obtain statistically and qualitatively useful information to the research topic. They were structured in a simple but logical order to grab the views & opinions of the participants. Blank spaces were provided for any observation or comments. The questions which generate irrelevant information to research questions were omitted. Collecting only the appropriate data, making data comparable

and amenable to analysis, minimizing the bias, grabbing the real opinion of the participants were the points which were focused by questionnaires.

The sample of population of on-line applicants (OLA) was delivered the questioner by E-mail. Telephone conversation was used to motivate the OLA in order to return back the filled questionnaires through E-mail. Further clarifications were done using telephone conversations. The questionnaire for sample population of manual applicants (MA) was delivered by postal mail. If any further clarification on given answers, they were re-questioned via telephone. Questionnaires for non-applicants (NA) were delivered manually. When arise a clarification by the NA, it was briefed verbally. The main objective of questioning NA was to identify whether this new PCCIS is familiar and conversant with the Sri Lanka general public. Hence this sample of population consisted with population over the age of 16 and representing different social status. No deep classification was done because the main intention of the researcher was to get a general view on citizens' familiarity on PCCIS.

2) Interviews: Interviews, as the instrument for data collection in this study, was mainly used to identify the history of PCC and to identify the current practices in the process. Interviews were supported in this study to find the valuable information because the related written document and details on the system had been destroyed or misplaced.

3) Observation Method: Though the observation is a complex research method, the researcher puts himself in the actual situation and watch carefully. The researcher uses observation method with the objective of observing people in their natural setting. Observation was found more suitable in order to overcome the criticism of validity of data and biasness of the study. The

researcher, himself, observed the Police Headquarter Clearance Unit (PHCU), manual applications handing over premises and other 12 local police area units. It was monitored available infrastructure facilities, manpower, space & comfort in premises, actual behaviour and response of the staff towards applicants.

4) Literature Survey: The researcher followed written research articles and sources available in the web to collect secondary data. The data available in the PHCU was collected and analysed. The secondary data were helpful to researcher to gain initial insight into the study area and it provided access to the work of scholars all over the world. It gave a frame of mind that in which direction the researcher should go in the study. Though it saved time and money the researcher was mindful on reliability and accuracy of content when using the secondary data sources.

#### D. Population and Sample Selection

The research population is generally a large collection of individuals or objects. Practically it cannot be tested every individual in the population. Hence in this study the researcher randomly selected comparatively adequate comprehensive group of individuals. The researcher's 1st target population was the PCC applicants. The 2nd target population was the Sri Lankan citizens. 3rd target population was the police officers who are engaging with PCC issuing process. The results of the study will apply to all population for whom the study was done. Randomization strategy was followed to create equal opportunity to each individual in the population. Every member of the population had a probability of being selected for the sample. It was created

adequate representativeness of the population in order to decrease sampling error and sampling bias.

#### E. Research Process

The researcher identified four research question in related to PCCIS. Literature review was done to gather the knowledge in related field. Research objectives were made. Data were collected pertaining to the research questions and objectives. Data were analysed and the recommendations were made according to the findings and results. The data analysing tool was SPSS. The findings of interviews and observations were evaluated manually.

#### Result and Discussion

Covering all research questions, identified, this analysis was conducted critically evaluating all the data collected. The results in the study is categorized to following sub topics.

- A. Efficiency and Effectiveness
- B. Organizational Bureaucracy
- C. corruption
- D. Infrastructure facilities, Manpower & connectivity
- E. New technologies and strategies to develop the system
- F. The citizens' familiarity with PCCIS

#### A. Efficiency and Effectiveness

Efficiency and effectiveness are two main management tools assess the organizational productivity. In this study it was tested whether the PCCIS is efficient and effective to fulfil the applicants' expectations. Following four aspects were tested in order to check the efficiency and effectiveness of PCCIS and results are shown below as a percentage.

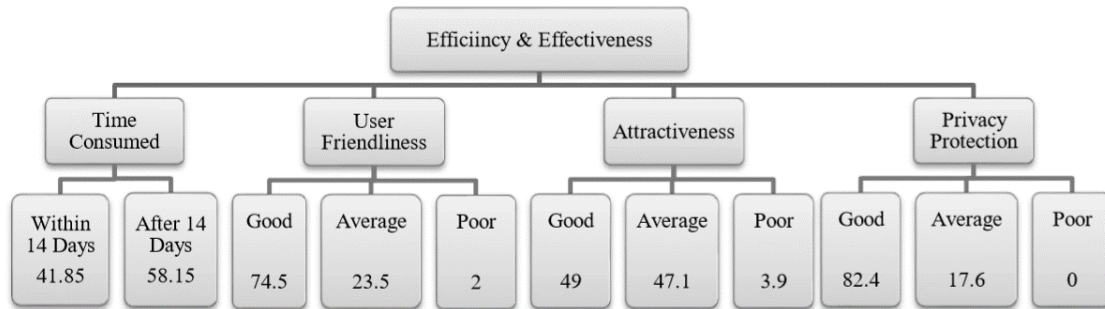

Figure 2: Efficiency and Effectiveness  
 Source: By Researcher (2019)

- 1) Time consumed to complete the PCC process
- 2) User friendliness of PCCIS
- 3) Attractiveness of PCCIS
- 4) Protecting privacy and confidentiality of the applicants

1) Time consumed to complete the process: PCCIS web page states that the PCC will be issued within 14 days if it is submitted appropriate particulars. Researcher tested actual consuming time of issuing PCC by MA, OA, 2018 January randomly selected applicants & 2019 January randomly selected applicants. It was revealed that 72.5% of OA & 50% of MA haven't got their certificates within 14 days. 58% of the selected samples in January 2018 and 52% of selected samples in 2019 have not got their PCC within 14 days time. After statistically calculation of above four findings, more than 58% of the applicants haven't obtained it within 14 days. This study revealed that there is a delay in the process and the customers has not meet their service requirement efficiently.

2) User Friendliness: 74.5% of OAs stated that PCCIS is user friendly. Most of OAs proposed advancements like Chatbot, self-downloading facility, Auto Save option, eForm, states checking, SMS service & channels for customer feedback etc. to improve the friendliness in the system.

3) Attractiveness: Attractiveness is a vital substance not only in a computer system but also in every aspects in the life. Comparatively 95% population are happy on attractiveness of SLP web page. The 5% OA commented that the SLP webface must improve with simple and descent appearance reducing it's complexity and turbulences.

4) Protecting the privacy and confidentially: Privacy protection is vital because the PCC is a job done with applicants' personal informations. If the PCCIS staff are fail to keep safe the personal and sensitive details of applicants it can be created many social issues and embarrassing situations. This study revealed that almost all applicants are confident enough on privacy protection by the SLP.

B. Organizational Bureaucracy

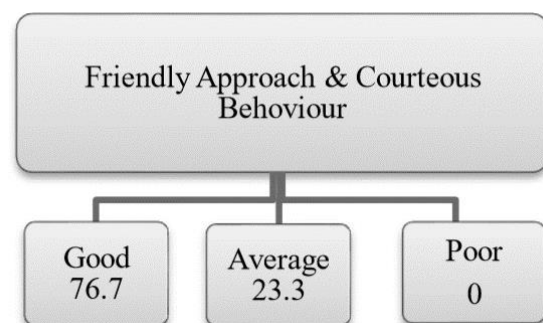

Figure 3: Efficiency and Effectiveness  
 Source: By Researcher (2019)

Bureaucracy is the one of main criticisms against public services. The influence which

was made by PCCIS on organizational bureaucracy was evaluated in this study. It was revealed that none of applicants in this study were treated indecently. But it was revealed some poor attentiveness in telephone conversations. Tri languages incompetency of the Police Clearance staff had created embarrassments and frustrations to Tamil and English speaking applicants. Some MA had specially suggested that distinctive attention and care must be given for the people like elderly, pregnant, disable when the MA are in the queue to handover the applications. In field observations the researcher witnessed that the PCC staff were attending with the applicants in friendly and cheerful manner. No delay of attendance was observed. But there was inadequacy of basic facilities like seating, photocopier, drinking water and lavatory in the office premises. The bureaucratic approach has been remarkably reduced because of less physical participation in new PCCIS process.

C. corruption



Figure 4: Corruption  
 Source: By Researcher (2019)

None of OA or MA in this study hadn't been subjected for bribing or corruption. They hadn't pay any additional payment than to the stipulated amount. Hence it was revealed that the PCCIS has supported to enhance the transparency in PCC issuing process. This is good evidence that the E-government approach always supports to reduce corruption because of transparent phases.

D. Infrastructure facilities, Manpower & connectivity

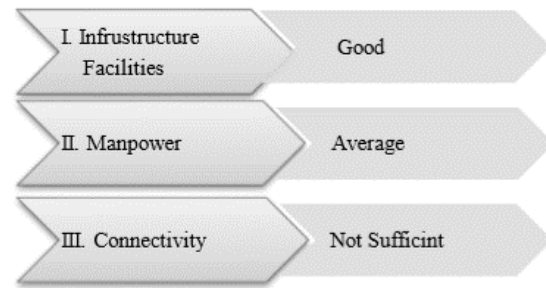

Figure 5: Infrastructure facilities, Manpower & connectivity  
 Source: By Researcher (2019)

This study checked whether the respective attending units have been facilitated with necessary equipment, man power and internet bandwidth. SLP has internet leased line of 100Mbps and annually the SLP pays more than Rs. 138000000/= on VPN connections to Sri Lanka Telecom. The internet bandwidth are not sufficient to fulfil the current requirement. As a consequence the efficiency has slowdown. With the available high demand it must be upgraded the main connectivity.

Both the face to face interviewees' and telephone interviewees' common opinion was that the manpower should be increased with the present-day requirement. Headquarter Unit has enough computers. Each regional units also have been equipped with adequate computers. But sometimes there are delays with repairs, installations and supplying of new machines to the regional units.

Vesting of VPN staff for other duties, in some stations, has created negative effects. In some stations VPN operators don't deploy at night. Some police stations, the OIC/HQI doesn't directly approach to the VPN. Instead, the VPN operator make a print of the messages produce to the OIC/HQI. This negative practice must be discouraged in order to achieve the objectives of E- governance.

E. New technologies and strategies to develop the system

In this study the researcher could to explore many technological and practical advancements to amalgamate with PCCIS. Those areas to be developed has included in recommendations of this study.

F. The citizens' familiarity with PCCIS

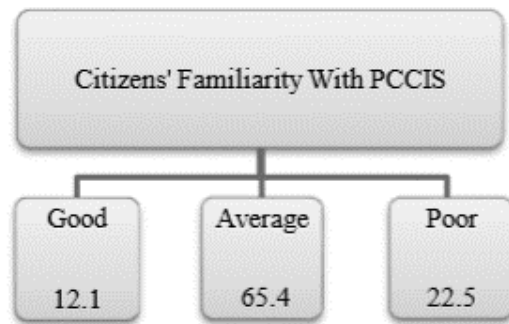

Figure 6: The citizens' familiarity with PCCIS  
Source: By Researcher (2019)

PCCIS had been the first on-line experience of 67% of OA. High majority of MA are not aware with this PCCIS. 88% of NA's knowledge on government on- line services are average or below to the average. 1/3 of NA know nothing on Sri Lanka police on-line services.

Over all majority of public are not conversant with the on-line facilities providing by the SLP. Some are not rely on on-line services and others are not conversant with new technologies.

As a summery, the efficiency of PCCIS is not adequate because more than half of the applicants don't get it within 14 days' time. The three components, namely, user friendliness, attractiveness and privacy protection, which was considered as main criteria in the effectiveness of the system, are comparatively good. But, still, there are many new technologies and mechanisms to be coped up with in order to upgrade the system effectiveness as mentioned in recommendations. Most importantly PCCIS has reduced organizational bureaucracy and

corruption. The infrastructure development and implementation of new technological strategies, identified by this study, will enhance the quality of the service ensuring the global security, as a key requirement in today.

### Conclution and Recommendations

This study was done in order to find the answers for 4 research questions mentioned above. Research is the tool for the innovations and improvements in any field. Maturity is not a destination but a never ending process. This topic in this study was selected in order to develop the PCCIS by identifying the gaps available with other global on-line systems. I hope this study will direct and motivate SLP to improve PCCIS with proposed recommendation.

#### A. Recommendations to Enhance the Sri Lanka Police on-line Clearance System

Following recommendations are made in order to upgrade the PCCIS as more friendly, efficient and attractive service.

1) Biometric verification must be applied in order to uniquely identify the applicants. Biometric verification is a method by which a person can be uniquely identified by evaluating one or more distinguishing biological traits likes fingerprint, hand geometry, earlobe geometry, retina patterns, voice waves or DNA (Rouse, 2008). (Ahmed, 2019) The Department of Registration of Persons must initiate to accomplish this. Following conceptual diagram depicts the directions for respective task.



Figure 7: Personal Data Warehouse  
Source: By Researcher (2019)

- 2) The PCCIS should be developed with,
  - a. A Chatbot via auditory or textually (Team, 2018)
  - b. Secured self-downloading facility using Digital Signature or QR code (WordPress, 2019) (Direct,2019)
  - c. Auto Save option
  - d. Improved file uploading size and capacity
  - e. eForm facility to download the application, fill it and uploading to the system (India, n.d.)
  - f. Improved “status checking” facility
  - g. Braking the PCCIS application in to sub categories like personal details, professional details, document downloading etc.
  - h. Auto calculation and auto filling technology
  - i. Improved web interface with simple and descent appearance
  - j. System advancements to prevent the problems like missing the web page and system stuck

- k. Speed delivery & courier service facility with additional chargers
  - l. Channels for customer feedback and grievances 24×7 basis (Haije,2017) (Pal,2018).
  - m. SMS service to update the customers on progress of the process
- 3) Maintaining of comprehensive Data base on PCC applicants by PCC Headquarter Unit.
  - 4) Assigning CRD as 7th consulting agency in PCCIS.
  - 5) Establishing a National E-government Platform and Data Warehouse comprising with the man-made intelligence and Artificial Intelligence (AI) to perform the tasks and decision makings as shown in following diagram. (RIGANO, 2018)



Figure 8: National E-government Platform and Data Warehouse  
Source: By Researcher (2019)

- 6) Most importantly, the public must make aware on available SLP on-line services through electronic media and other medias.
- 7) Language capacity and the healthy communication skills of the PCC staff must be enhanced by undergoing them for proper trainings with exposure.

Efficient law enforcement mechanism is a prime requisite in any state. When the security is under the threat vulnerability is ubiquitous. This study was done in order to strengthen the SLP technologically. SLP by her vision statement gives utmost confidence for her citizens. Her motto is decorated with very attractive jargons like people friendly, professional and prestigious. Empowering the police with professionalism is timely requirement. Today world we can't utter the word professionalism forgetting the technology. If the SLP can effectively integrate the recommendations made by this study it will pave the way to upgrade the PCCIS and E-governance in SLP.

## References

- Ahmed, A., 2019. What is biometric verification system?. [Online]  
Available at: <https://www.m2sys.com/blog/biometric-resources/what-is-biometric-verification-identification-authentication-system/>
- Bose, S. & Rashel, R., 2019. Implementing E-Governance Using OECD Model (Modified) and Gartner Model (Modified) Upon Agriculture of Bangladesh, s.l.: s.n.
- Direct, S., 2019. Digital Signature, s.l.: s.n.
- GIC, 2007. About GIC Website. [Online] Available at: <http://www.gic.gov.lk/gic> [Accessed 20 March 2019].
- Haije, E. G., 2017. 30 Best Customer Feedback Tools: an overview, s.l.: s.n.
- ICTA, 2015. eGovernment Policies and Procedures.  
[Online]  
Available at: <https://www.gov.lk/elaws/wordpress/wp-content/uploads/2015/03/eGov-Policy-structured-v4-0.pdf>  
[Accessed 07 February 2019].
- INDIA, G. O., n.d. Digital Police. [Online] Available at: <https://digitalpolice.gov.in/> [Accessed 10 March 2019].
- India, G. o., n.d. Grievance/Feedback. [Online] Available at: <https://portal2.passportindia.gov.in/AppOnlineProject/>. [Accessed 15 March 2019].
- India, G. o., n.d. Online Form Submission. [Online] Available at: <https://portal2.passportindia.gov.in/AppOnlineProject/welcomelink#>
- INDIA, G. O., n.d. Police Clearance Certificate (PCC).  
[Online]  
Available at: <https://www.mea.gov.in/police-clearance-certificate.htm> [Accessed 15 March 2019].
- Kanchana, D. G. & Samarakoon, A. K., 2018. The Role of E-governance in curbing public-sector corruptions (A Theoretical Overview). 27 June.
- Pal, J., 2018. How to Get Quality Customer Feedback – 20 Effective Methods. 23 July.
- Rigano, C., 2018. Using Artificial Intelligence to Address Criminal Justice Needs. 08 October.
- Rouse, M., 2008. Biometric Verification. Techtarget, May.
- Singapore, G., 2018. Singapore Police Force. [Online] Available at: (<https://eservices.police.gov.sg/content/policehubhome/homepage.html>)
- SLP, 2018. Sri Lanka Police Vision & Mission. [Online]  
Available at: <https://www.police.lk/> [Accessed 05 November 2018].
- Team, E. S., 2018. Chatbot: What is a Chatbot? Why are Chatbots Important?. [Online]  
Available at: <https://expertsystem.com/chatbot/>  
[Accessed 11 February 2019].
- WordPress, 2019. What is a QR Code: A Beginner's Guide.  
[Online]  
Available at: <https://scanova.io/blog/what-is-a-qr-code> [Accessed 15 January 2019].

## Acknowledgment

I would be highly grateful to Dr. Pradeep Kalansooriya

- Head of the Department - Computer Science on his correct guidance and motivations to conduct a genuine research, not only for study purpose but for the system development in the Sri Lanka Police.

My sincere appreciation goes to ASP Tharaka Senevirathne of Police IT Division, Mr.Millewithanarachchi – The Criminologist of SLP, CI Nishantha Priyananda of CRD, SI R.W.M.M. Rathnayake and the staff of Police Clearance Unit. Mr. Kasun Panditha and the staff of Police Welfare Division who sacrificed their time with me to complete a healthy research.

I would be thankful to my wife Samadhi for the assistance gave to succeed this effort.

### Author Biographies



H.A.N.K. Damayantha Wijaya Sri, the researcher, is the Deputy Inspector General in Monaragala. He has obtained his BA Degree from Univrsity of

Peradeniya. He has completed his LLB Degree at OUSL and MBA at KDU. He has followed Psc by Defence Services Command and Staff Collage - Sapugaskanda and has completed 19 years professional carrier in Sri Lanka Police and UN. At present he is a registered student of PhD at KDU.



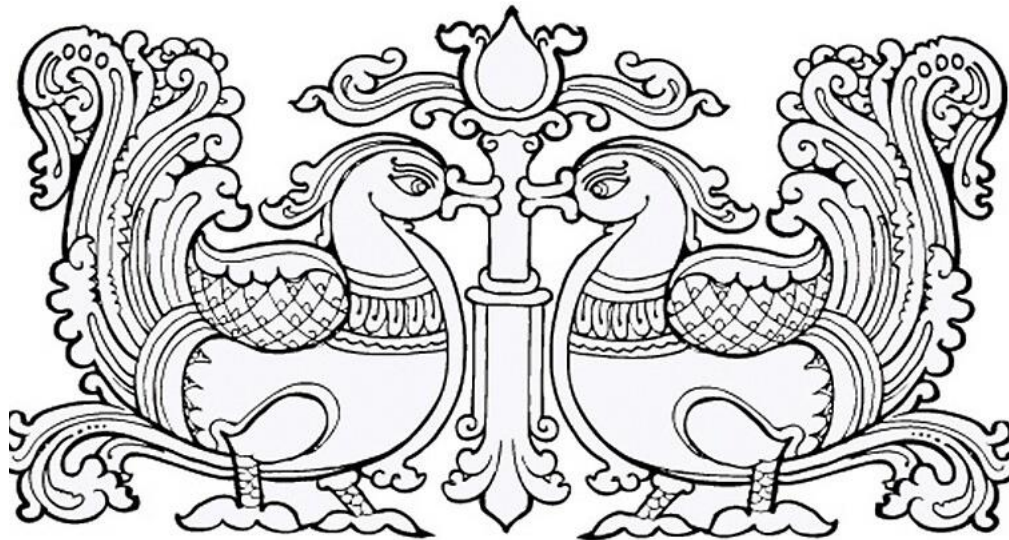

# POSTER PRESENTATIONS

## Recursive Image Segmentation for Vehicular Traffic Analysis

Manusha Eeshwara<sup>#</sup>, Rohana Thilakumara, Niranga Amarasingha

*Faculty of Engineering, Sri Lanka Institute of Information Technology*

<sup>#</sup>manusha.e@sliit.lk

**Abstract:** Many methods have been proposed for image segmentation in vehicular traffic analysis using traffic camera video footage. However, isolation of moving objects with perfect object boundaries has been a challenging problem in vehicular traffic analysis. Usually these vehicle objects are extracted inside rectangular boundaries with extra irrelevant background image pixels from other objects included in the analyzed image. Thus using such segmentation methods in vehicle identification using video is not favorable for feature extraction for classification of vehicle category. This work proposes a method to deal with irregular shaped image segmentation for vehicle identification using a recursive algorithm. A binary thresholded image composed of white and black pixels is filtered with a 2D low pass filter to isolate irregular shaped image boundaries of objects. Then recursive image segmentation is applied on the filtered binary image. White pixels in the 2D filtered image are used to identify the presence of the object. If the neighboring pixels of the pixel of interest are also white, then those neighboring pixels are recursively processed the same way to account for the extent of the object. This recursive collection of pixels bounded by an irregular shaped boundary is continued until neighboring pixels are significantly different in color from the pixel of interest. From this recursive image segmentation algorithm, extraction of all pixels of odd shaped objects done in an efficient manner. Accordingly, pixels count, height and the width of the object are recorded. This image segmentation method has been successfully

applied to identify vehicle categories in traffic video sequences.

**Key Words:** Image segmentation, Vehicle identification, Irregular shape

### Introduction

Image processing has evolved for better interpretation of images by humans and data storage, analysis and transfer. Current use of image processing has expanded to different fields such as medical, remote sensing, electronics and so on. The applications of image processing like feature extraction, object detection, image scanning have been relied on image segmentation as a pre-processing step. Thus, to find an appropriate segmentation algorithm based on the application and the type of input image is very important.

Several studies exist in the literature on image segmentation, vehicle detection and tracking. For example, Achanta et al. (2010) have presented SLIC superpixels image segmentation algorithm based on superpixels which can be used at a pre-processing stage in vision applications. The proposed methodology uses that cluster pixels with a combination of five dimensional color and image plane space to efficiently generate compact and nearly uniform superpixels and adhere well to region boundaries. The efficiency of superpixels has been proved in object category recognition and medical image segmentation. Zivkovic et al. (2004) have presented color histogram based non rigid object tracking. The algorithm is able to robustly track objects in different situations and also can adapt to change in shape and scale. Human faces

tracking was the primary goal of this algorithm but as experimentation done, it can be used for other objects also. Ma et al. (2012) conducted a study on Canny edge detection and its improvements. It takes input gray scale image and produces output image showing the positions of tracked intensity discontinuities. The main purpose of this study is to image segmentation and extract shape information thus most of the shape information of an image is enclosed in edges. Rhouma et al.(2013) has presented improving the presence of Hu moments for shape recognition. subdomains, and computing their invariant moments. This division does not result in any extra computations. The result is regular Hu moments tend to give way more weight to pixels that are farthest from the center of gravity used to improve shape recognition. Viola et al.(2001) has presented an approach which describes machine learning for visual object detection which is capable of processing images rapidly and high detection rates. In the domain of face detection the system capable of detection rates comparable to the best previous systems. The methodology can be used to detect vehicle categories in different traffic conditions. Bas et al. (2007) have presented a new traffic video analysis method that accounts for the geometry of the scene where adaptive bounding box size is used to detect and track vehicles according to their estimated distance from the camera. In the proposed methodology vehicle detection is done by background subtraction. To distinguish moving vehicles from the static background, Gaussian Mixture Modeling has been modeled with a background scene. A mask of the road is extracted first to reduce search space. Kalman filter has used for tracking vehicles extracted from background models. According to the results section problems with tracking mostly occurred due to foreground segmentation and cameras are affected from environmental factors. In the

past several image segmentation algorithms reported in the literature have used pixel based segmentation, edge based segmentation and region based segmentation (Hoover et al., 1996). These types of models have their pros and cons, and the choice of them in applications depends on different characteristics of images. Even with good illumination, pixel based segmentation methods result in a bias of the size of segmented objects when the objects show deviations of the gray values. Accordingly brighter objects emerge as large ones, while darker objects emerge as small ones. The size variations will not occur if we consider the edges of the image by taking the mean of the object and background gray values as the thresholds. However, the edge based segmentation approach is only possible if all objects show the same gray value or if different thresholds for each object are applied. An edge based segmentation approach can be used to detect image boundaries. This type of highly localized image information is adequate in some situations, but has been found to be very sensitive to image noise. Region based methods are significantly less sensitive such as the effects of noises. However, the region-based methods also have weakness in which they do not make use of local image information and will lead to inaccurate segmentation.

This work demonstrated on, and in part motivated by, the task of vehicle identification. Road traffic congestion has become a major issue in populated cities. Since the goal of our final system is to help the traffic management to predict traffic congestion prioritizing safety and sustainability. To identify vehicular features, Isolation of moving objects with perfect object boundaries has been a challenging problem in vehicular traffic analysis. But how can this be achieved if the segmented moving object contains extra irrelevant background

image pixels? However isolation of real life objects with perfect object boundaries have been a challenging problem using above segmentation methods. Usually these vehicle objects are extracted inside rectangular boundaries with extra image segments from other objects included in the analyzed image.

The main objective of this study is to detect the moving objects in a traffic scene and extract them with irregular shaped boundaries for vehicular identification. Although a number of research studies have been conducted in several countries in the area of vehicular identification (Bas et al. 2007, Michalopoulos, 1991). This paper brings a new algorithm for image segmentation for irregular shaped objects consequent to identify vehicle category. The proposed recursive algorithm is most clearly distinguished from previous approaches in its ability to detect irregular shaped images. In other image segmentation algorithms, usually images are extracted in rectangular boundaries with extra irrelevant background image pixels. It is very important to extract only the vehicular image without background image pixels which are irrelevant to moving object for feature extraction and classification of vehicle category. The stability of vehicle classification method is vulnerable to various environmental variations, such as illumination, noise, vehicle shadow, angle of cameras and weather related anomalies in the image.

The remainder of the paper describes our contributions, a detailed description of our experimental methodology and experimental results. Finally concludes this paper and describes directions of future work.

### The Proposed Methodology

The proposed algorithm is an image processing algorithm capable of extracting comparatively high percentage of pixels of a

moving object. Background subtraction technique in (Radhakrishnan, 2013, Hardas et al., 2015) used to identify moving objects eliminating static objects from a video sequence. A binary thresholded image composed of white and black pixels is filtered with a 2D low pass filter in (Cabello et al., 2015, Gedraite et al., 2011) to isolate irregular shaped image boundaries of objects. Thus the white pixels are considered as the pixels of the moving object. Figure 1 shows a grey-scale frame from a video sequence (left) together with the detected moving objects pixels image (right) is contained white and black pixels. Then the resulting binary image which consists of white and black pixels is analyzed using the proposed recursive algorithm. A set of pixels in which each pixel is connected to all other pixels is considered as a one object. From this recursive algorithm all connected white pixels are recorded to an array. White pixels are used to identify the presence of an object. Subsequently all the objects in an image extract in an efficient manner. Accordingly, the pixels count, height and width of the objects are recorded.



Figure 1: A grey-scale frame from a video sequence (left) together with the detected moving objects pixels image (right)

### The Algorithm

These are the steps we have followed for extracting moving objects from a sequence of video frames. A video frame is considered as an image.

Algorithm steps:

1. Convert the color image in to a grey-scale image
2. Use background subtraction to isolate moving objects in the image.

3. Then smooth the image, by taking a 5X5 smoothing kernel over the entire image matrix.
4. Apply a 2D low pass filter to obtain an irregular shaped white blob corresponding to each moving object.
5. Scan the binary image left to right and top to bottom, until you find a WHITE pixel in a selected region of the image.
6. If the pixel is WHITE and not marked in the Scratch\_Pad\_Image\_Array, mark the corresponding grey-scale pixel value to a Scratch\_Pad\_Image\_Array.

Else check the next pixel.

7. If the white pixel P is within the selected region, four recursive functions call from the

Eastern, Southern, Western and Northern pixels to the P.

Repeat step 5 in each recursive function.

Calculate the sum of pixels in each irregular shaped object.

This recursive collection of pixels bounded by an irregular shaped boundary continues until neighboring pixels are significantly different in color from the pixel of interest.

Calculate the height, width, mid point of the object

If pixel summation > minimum vehicle pixel count, Increase the objects count by 1

Repeat steps 5 and 6

Throughout this entire algorithm maximum percentage of moving objects in a video is captured in an efficient manner. Save the irregular shaped object image to a folder. Image dimension equals to height and width of the object.

## Results and Observations

The algorithm was used to extract different odd shaped objects. Moreover, this method has applied to real image frames of videos of vehicles. These videos have been captured from different angles and distinct traffic conditions. The pixels of vehicles have been extracted including the moving casted shadow.

Data identified in each object of a video frame are the number of objects in a frame, pixel count, height, width and midpoint of the object. The required images for the proposed work are acquired with the help of a digital camera. The frame speed of the camera was limited to 25 frames per second. The real time video sequences are acquired with the frame size of 1280 x 720 pixels resolution. In order to check the efficiency of the proposed algorithm, the experiment is performed repeatedly with five number of three minute different traffic videos. In our research six vehicle types have been considered for the results.

Table 1 shows the accuracy percentage of the number of vehicle extraction obtained for different vehicle types. The algorithm was found to have underperformed because of excessive reflection of sunlight and shadow effects leading to erroneous detections and undetected vehicles. The missing number field in table 1 represents the vehicles that were not segmented successfully because they were extracted in combination with other vehicles. The '\*' mark denote in the table 1 stands for the average accuracy may not accurate due to insufficient number of data. Average accuracy of the table 1 is 95.6%. Table 2 shows the accuracy percentage of image pixels extraction of different vehicle types. The results depicted in table 2 is evident that the proposed algorithm is well suited for image segmentation. Average accuracy of the table 2 is 93.2%. The average accuracy percentage is an approximate value. The vehicle categories in table 1 and table 2 decided

visually and the pixels extraction percentage in table 2 is a visual count.

*Table 1: Results of vehicle extraction from the video sequence*

	Motor Bike	Car	Van	Three wheel er	Bus	Truck
Actual number of vehicles	91	97	7	44	2	16
Extracted number	83	89	7	40	2	16
Missing number	8	8	0	4	0	0
Average accuracy %	91.2	91.7	*100	90.9	*100	*100

Accuracy - 95.6%

*Table 2: Results of pixels extraction percentage of vehicle types*

	100% - 95%	95% - 90%	90% - 85%	85% - 80%	Average accuracy %
Number of Motor Bikes	55	27	1	0	94.4%
Number of Cars	45	34	9	1	93.9%
Number of Vans	4	3	0	0	94.7%
Number of Three Wheelers	14	17	9	0	92.8%
Number of Buses	1	1	0	0	92.6%
Number of Trucks	4	9	3	0	91%

Accuracy - 93.2%

Figure 2 shows the irregular shaped vehicular segments obtained as results using the proposed method. The results depicted do not contains irrelevant background image segments from the background due to irregular shaped segmentation of images.



*Figure 2: Irregular shaped vehicular segments obtained using recursive image segmentation algorithm*

### Conclusion

An approach for irregular shaped object extraction with a high accuracy using a new recursive algorithm is presented in this paper. Throughout this paper the work that has been carried out on image processing domain about image segmentation for irregular shaped objects is briefly discussed. This image segmentation method has been successfully applied to identify vehicle categories in traffic video sequences. The proposed method gives a success rate of more than 95% in irregular shaped image segmentation. This paper will encourage the further initiatives to be taken for implementation of work in such a domain. This image segmentation method has been successfully applied to identify vehicle categories in traffic video sequences. The vehicle classification method is sensitive to various environmental variations, such as illumination, noise, vehicle shadow, angle of cameras and weather.

### Future Work

As mentioned in the beginning the new recursive image segmentation algorithm will be further extended in order to identify vehicle types in traffic video sequences. The image segmentation is a very vast area with its literature and applications. In future research, this can be extended to identify vehicle categories in traffic video sequences. The feature vectors of each irregular shaped objects extracted using the new image segmentation algorithm could be used to

image identification. A state machine for vehicle classifier can be implemented with a machine learning algorithm. However, it is needed to improve robustness against environmental noise, sudden illumination and shadow effects.

### Acknowledgment

This research was supported by the Accelerating Higher Education Expansion and Development (AHEAD) Operation of the Ministry of Higher Education funded by the World Bank.

### References

Achanta, Radhakrishna and Shaji, Appu and Smith, Kevin and Lucchi, Aurélien and Fua, Pascal and Süsstrunk, Sabine (2010). SLIC superpixels. Technical report, EPFL.

Bas, Erhan & Tekalp, A. & Salman, F.. (2007). Automatic Vehicle Counting from Video for Traffic Flow Analysis. 392 - 397. 10.1109/IVS.2007.4290146.

Cabello, F., León, J., Iano, Y. and Arthur, R. (2015). Implementation of a fixed-point 2D Gaussian Filter for Image Processing based on FPGA. Poznan: 2015 Signal Processing: Algorithms, Architectures, Arrangements, and Applications (SPA), pp. 28-33.

Emami, E and Fathy, M. (2011). Object Tracking Using Improved CAMShift Algorithm Combined with Motion Segmentation. Tehran: Machine Vision and Image Processing (MVIP), pp. 1-4

Gedraite, E. and Hadad, M. (2011). Investigation on the effect of a Gaussian Blur in image filtering and segmentation. Zadar :Proceedings ELMAR-2011, pp. 393-396

Hardas, A., Bade, D. and Wali, V. (2015). Moving Object Detection for Video Surveillance using Different Color Spaces. International Journal of Computer Applications 118(13), pp.39-43.

Hoover, A., *et al.* (1996). An experimental comparison of range image segmentation algorithms. IEEE Transactions on Pattern Analysis and Machine Intelligence vol. 18, no. 7, pp. 673-689.

Michalopoulos, G. (1991). Vehicle detection video through image processing: the autoscope system. *IEEE Transactions on Vehicular Technology*, 40(1), pp. 21-9.

Negri, P., Clady, X., Milgram, M. and Poulénard, R. (1991). An Oriented-Contour Point Based Voting Algorithm for Vehicle Type Classification. Hong Kong:18th International Conference on Pattern Recognition (ICPR'06), pp. 574-577.

Radhakrishnan, M. (2013). Video object extraction by using background subtraction techniques for sports applications. Digital Image Processing, 5(9), pp. 91-97.

Viola, P and Jones, M. (2001). Rapid Object Detection using a Boosted Cascade of Simple Features. Kauai: IEEE Conf Computer Vision and Pattern Recognition. pp. 1-1

Wimalaratna, L. and Sonnadara, D. (2008). Estimation of speeds of moving vehicles from video sequences. Proc. 24th Technical Session, Sri Lanka, pp. 6-12

Zhengqin, L and Jiansheng, C. (2015). Superpixel segmentation using Linear Spectral Clustering. Boston: *IEEE Conference on Computer Vision and Pattern Recognition (CVPR)*, pp. 1356-1363.

## “TrainGo App” - Mobile based Train Ticketing System for Railway Department in Sri Lanka

A. D. Supun Nimesh<sup>1</sup>, Samanthi Wickramasinghe<sup>2</sup>, Sunesh Hettiarachchi<sup>3</sup>

<sup>1,2</sup>Faculty of Information Technology, Horizon Campus, Malabe, Sri Lanka

<sup>3</sup>TECH Computers, Sri Lanka

samanthi@horizoncampus.edu.lk

**Abstract:** The Railway Department in Sri Lanka uses a traditional method to issue tickets to their passengers through counters who use short distance travel. Because of that passengers have to wait a long time in the queue to get their ticket and there is a possibility of miss the train. Hence, most of the passengers have a bad impression of train service in Sri Lanka.

The purpose of the system is to provide better service to the passengers by enhancing the ticket issuing process and improving good impression about the railway service in Sri Lanka

“TrainGo” mobile-based train ticketing system uses a QR Code scanning mechanism to reserve and purchase tickets.

The mobile-based train ticketing system provides a better service to the passengers by enhancing the ticket issuing process. Dynamic QR codes, E-Wallet system, Ticket booking system, Report generating system, and Admin backend panel are the main processes of the mobile-based train ticketing system. The QR Codes for the stations are generated by the devices dynamically based on the station and date.

The React framework, the Vue-electron framework, and node.js were used to develop the “TrainGO” app. Couch DB and the Pouch DB were used as the databases for the development purpose. Marvel App was used to design the App

It was identified a few similar types of systems in other countries during the

literature review, but those systems were not used technology which uses in the “TrainGo” app. Hence, the “TrainGo” app uses unique technology.

**Key Words:** Mobile App, Railway Ticketing System

### Introduction

At present, the bus and trains are the two (2) main public transportation modes in Sri Lanka. According to the Transport Department over 90% of people in our country use one of these transportation methods to fulfill their daily transportation needs. Sri Lankan Railway Department uses a traditional method to issue tickets to their passengers on short-distance travel. Because of that passengers have to wait a long time in the queue to get their ticket and there is a possibility of miss the train. Hence, most of the passengers have a bad impression of the railway service in Sri Lanka.

The objective of developing the system is to provide better service to the passengers by enhancing the ticket issuing process and improving good impression about the railway service in Sri Lanka. Train Passengers, Ticket Checking Guards, and Station Masters are the main users of the app. The mobile-based train ticketing system provides a new ticket purchasing method using QR codes, ticket reservation system, payment through an E-Wallet system, Report generating system, and Admin backend panel for the backend purposes.



## Literature Review

It was identified a few similar types of systems in other countries during the literature review.

An online railway booking system in China provides their passengers to register, book and cancellation (Zongjiang, 2012). This system has a typical three-layer system. DB layer, Application service layer and the user interface layer. Normally the DB holds the data of user registration, ticket ordering, and ticket data. The Application service layer consists of the business logic of the Railway online booking system. This system has customer register function, customer cancellation function, searching function, booking function, refunding function. In the Customer register function you can purchase tickets after logging. In cancellation function, can cancel either a ticket or registration of a user. So the database deletes the records according to the user requests. In searching function, you can search for the train and it will return a bulk of information about the train. After checking the data of the ticket the cancellation and refund system happens. The business process of this is Customers register personal information, so they can order tickets in the system. Customers search for train information through the system and see whether having appropriate tickets, order tickets on the user interface. The system returns the result of ordering tickets information. Customers can select canceling operation for some reason, so the personal information will be removed from the system. In the database, they store data about the ticket, ticket message, customer, and the train details. They haven't given the programming language about the system but I think they are going to use java and MySQL for the program.

There is a railway ticket issuing system using a smart cards in India (Kumar & Ram, 2013). It consists of these items for the ticket issuing process. It is a completely new hardware and

software combination. Microcontroller, power supply unit, keypad, printer, display, smart card driver in each system. So these people creating a new machine for the smart card technology. According to their research paper, they first Insert the SMARD CARD and enter the secret password. Then check whether the entered password is correct or not. If the password is correct it will go to the next step. If it is wrong it will go to the previous step. Then we have to select our option from these two options 1. Recharge, 2. Ticket. If we select option 2, the following steps to proceed. Select our destination place and the number of tickets. Then the following details will be displayed ticket price, the number of seats, seat availability. The printed ticket will be collected from the printer else if we select option 1, the following steps to proceed. Enter the amount to recharge Confirm the amount to recharge or cancel. Then the following details will be displayed successfully recharged and remove your card. They are going to use these two software for the development PIC COMPILER and Proteus 7.6. So this system is not only a program, it is a complete system. They have these FLASH Program Memory, Up to 368 x 8 bytes of Data Memory (RAM), and Up to 256 x 8 bytes of EEPROM Data Memory. And also the smart card can be also reprogrammed.

A mobile solution for railway booking in India using a Wi-Fi to get tickets (Maheshwar, 2018). It used Wi-Fi facility in the train stations. Installation starts from registering the user to the system. After that, there is a typical login page for the user. So the user has to enter the information about the destination, no of tickets and about the return ticket or normal ticket. Then the user can see the price amount. Users can also view the existing account balance according to the user requirement. Users can also top up the application using manual payment or using a credit card. After that pdf type ticket will

generate in the device and at the destination user has to give that to the e-ticket checker application. Their expectation is to reduce the time in the ticket queue. They listed down the software requirements for this application as follows, Programming Language (Java) JDK 1.8, Operating System (Windows 7, 8, 10), Android Studio, and PHP as a server, Database (SQLite, Cloud). They have listed down the Hardware Requirements as Intel Pentium 4 processor or higher. Minimum RAM of 512mb. Free disk space of 16GB or more. 1024 x 768 resolution monitor. For the development purpose. They are using SQLite for the internal DB, QR Code Technology as technologies for the android application internal technologies. This system helped me a lot but there are some technological gaps so I am going to fix them in my application.

It was found another similar type of railway booking in India with the E-Wallet system (GIRINIVAS, 2015). E-wallet scheme ensures that registered customer is not directed to the bank's server for the payment every time, ultimately saving a considerable amount of time and increasing accuracy. So people can go and deposit some money in the IRCTC and they can access that money for the ticket buying. This application has a login function for the app and if the user is not registered have to register. Then the user can access that e-wallet and buy a ticket. There is a wallet button to see the credit balance. Users can use that to book the tickets also. Admin can log in and add fare details to the system. Users can buy tickets using that system. After the booking ticket user can see the details about the trip and also the fair. Then he can purchase that ticket using the E- wallet. The technology that they going to use for this system is android, SQLite, Eclipse, and Android Studio. Actually there are so many spaces in this system. So I am going to fix those spaces in my system. Their aim is to reduce the traffic in the system so user don't

need to access the bank servers all the time to purchase a ticket.

Most of the similar types of the system were used online booking systems and card-based systems (Brakewood, et al., 2014). According to this their tickets purchased and validated through smartphones. In their country they have a conductor and they show that ticket to the conductor. Using credit, debit card or any other payment method travelers can purchase a ticket using mobile. It happens real-time over the cellular network. Then the conductors have a machine to check the barcode of the ticket. So it can be validated using that system. This app is launched to android mobiles and iPhones. They can purchase multi-ride or single-ride tickets using the app. They have used the barcode system to validate the ticket. In the app you can see recent trips. After giving the information can review the details of the ticket. Then you can do the payment after the payment can see the barcode of the ticket. This barcode then validated using the conductors' app. So these people did some research to find some data about the user. The most used device during the past 30 days is the iPhone. It is about the US railway system. But in those days most people don't like to do online purchases. The users finally adopted the mobile ticketing system. They forecasted the future before introducing the system. With the spread of mobile devices, is likely to increase users in the future. From the first phase 26% of users liked to adopt this technology in the US. The simple but efficient system was designed for android and also IOS.

### **Research Methods**

Sample (N=400) consists of passengers and staff at the railway station. Interviews, Questionnaires, and Observations are used to collect requirements (Rouse, 2007). Figure 1 illustrates the features available in the

system based on the gathered requirements from the sample.

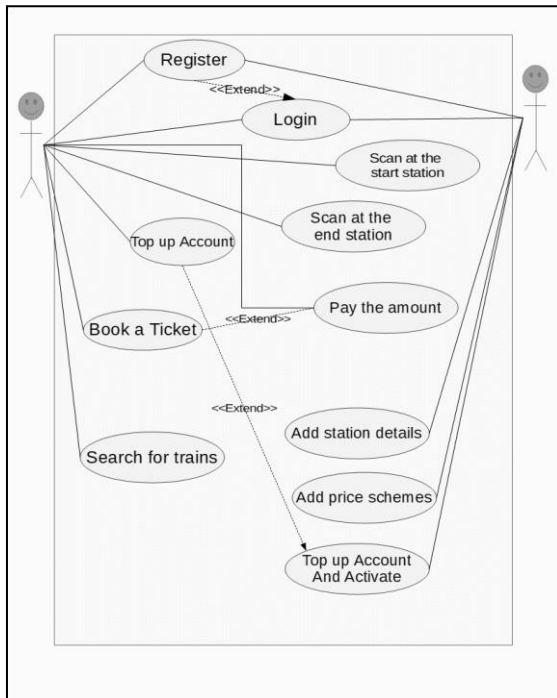

Figure 1: Use Case Diagram for the System

Main mobile app named TrainGO and the backend admin TrainAdminGO was developed. This process was time driven and developed to satisfy all the needs and wants of the Train Department in Sri Lanka.

Hybrid methodology was decided to use through the development process. Because of its advantages from the waterfall model and the agile method as it was the best methodology to use. For the development purpose react framework, the Vue-electron framework and node.js were used mostly. Couch DB and the Pouch DB were used as the databases for the development purpose. Marvel App was used to design the App.

### Result and Discussion

A mobile-based train ticketing system is developed by carefully analyzing the collected requirements. (1) Navigation must be simple, (2) easy to set up and use, (3) make quick the response, (4) payments must be easy, (5) user training are the expected requirements from the solution.

The train ticketing system has two (2) mobile applications. One application (TrainGo App) is for the train passengers and other applications (Train AdminGo App) for the station masters and guards. At present, most of the people in Sri Lanka use smart mobile phones. Therefore, the mobile-based train ticketing system “TrainGo” is a practical solution to issue and reserve tickets.

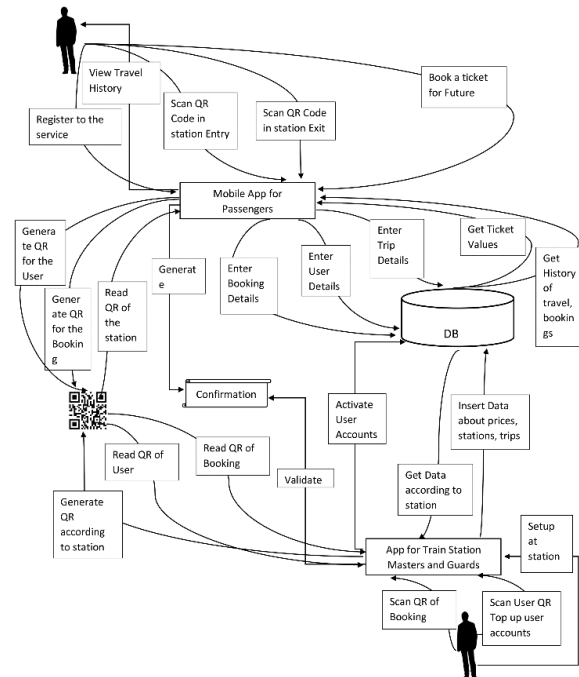

Figure 2: Overview of the Mobile based Train Ticketing System

Source: Authors Constructed

According to the above figure 2, there is a device placed in the railway station to display a QR code (QR code varies from the railway station and the date). Passengers have to scan the QR code which placed in the railway station using the “TrainGo” app before they start the journey and it gives users/passengers access ticket screens. Through the “TrainGo” app simply avoid purchasing a ticket from the counter which reduces the usual queue. While traveling, passengers can change their class and number of passengers. The tickets will be validated by train guards on the train. When the passengers arrive at the destination, they can scan the QR code in the respective railway station. Further, the system

calculates the total cost of the trip and it deducts from the e-wallet of the respective passenger that integrated into the app. The e-wallet can top up using a credit card, debit card, or cash.

Passengers can reserve their tickets using the “TrainGo” app. Once the reservation is made, the relevant data transfers to the DB and can be validated using the guard’s mobile application during the journey.

As there is no human to human involvement during issuing tickets or season pass, social distance can also be maintained at the railway station and no transactions through money which reduces the risk of Covid-19 Pandemic.

The new ticket purchasing method using QR codes, E-Wallet system, Ticket booking system, Report generating system, and Admin backend panel are the main features of the mobile-based train ticketing system.

In the manual system, the railway guard checks and validates the tickets. According to the passenger's requirements, they can use the E-Wallet facility to the top-up the available amount, check balance, and get notifications. Furthermore, passengers can reserve tickets by providing the date, time, and number of seats through the “TrainGO” app. User interfaces of the mobile-based train ticketing system are as follows:

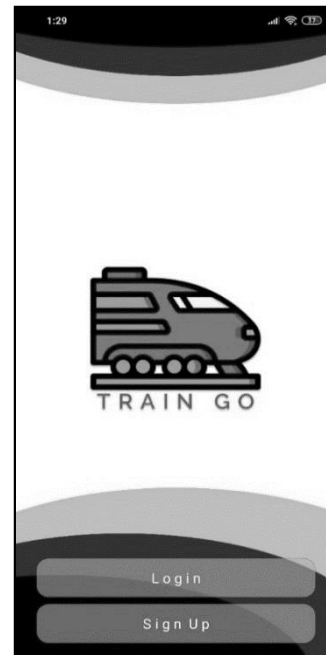

Figure 3: Login Page of the App

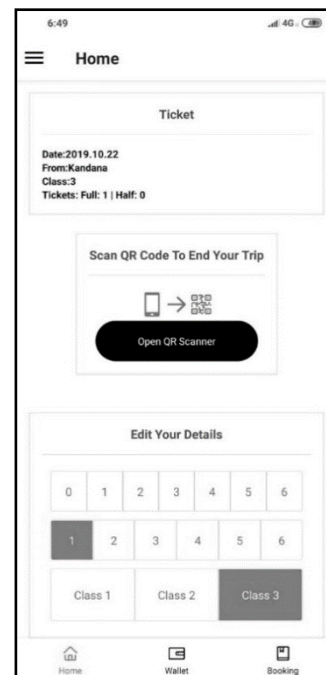

Figure 4. Scanning QR Code

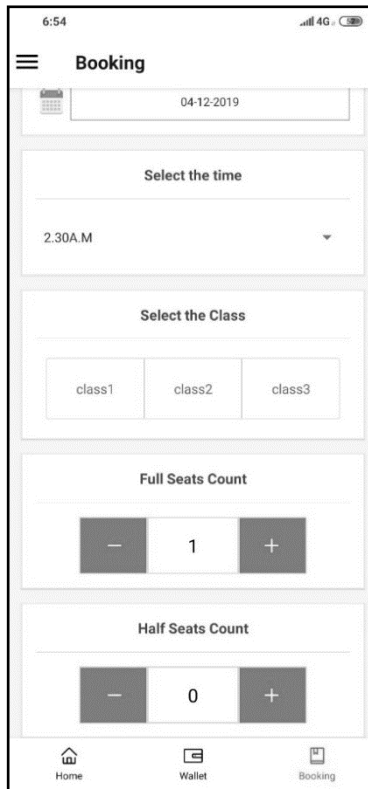

Figure 5: Make Booking Screen

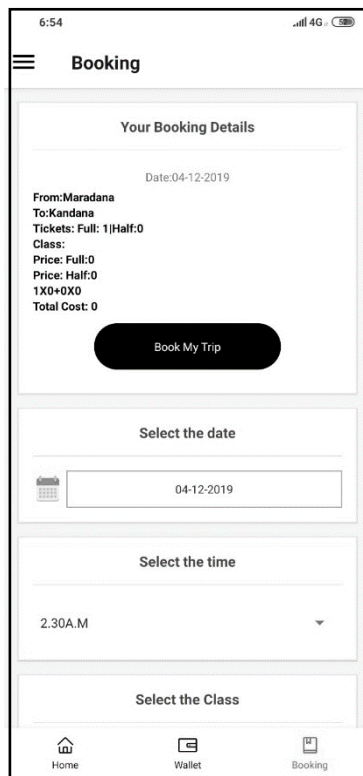

Figure 6: Change Booking Details

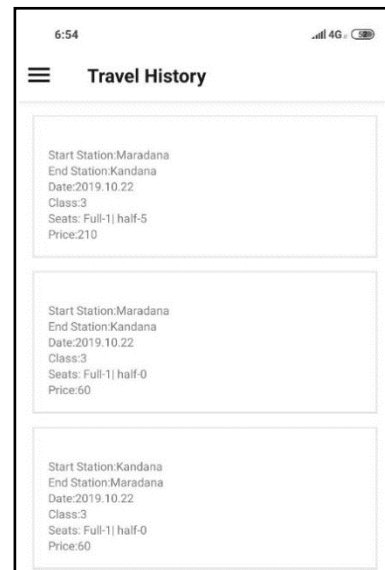

Figure 7: Travel History Details

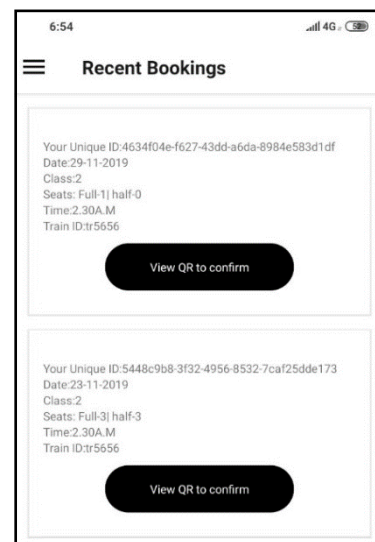

Figure 8: Recent Booking Details

It was decided to print QR codes and set it in train stations as the initial plan. But then, it was found that the static QR codes can be bypassed by the passengers. Hence, the QR Codes for the stations are generated by the devices dynamically, based on the station and the date. Through the E-Wallet mechanism, passengers can pay for the tickets, and also they can top up the E-Wallet system through a bank transaction, credit card, or debit card. These are the novelty features available in the “TrainGO” app which cannot find in the similar types of systems available in other countries.

Due to the limitations of testing the system in the real environment, the testing of the system is done in a simulated environment. Finally, this system can be installed in any device that runs Android OS. Accordingly, the generated QR codes can be pasted at several locations in the railway station which passengers can easily scan the code through their smartphone.

### Conclusion

Sri Lankan Railway Department uses a traditional method to issue tickets to their passengers who used short distance travel. As a result, long queues can be seen in ticket counters and passengers have to wait a long time in the queue to get their ticket and there is a possibility of miss the train. Hence, most of the passengers have a bad impression of train service in Sri Lanka. The mobile-based train ticketing system "TrainGo" provides a practical solution to those issues and it enhances the ticket issuing process, provides better service to the passengers, and impresses about the railway service in Sri Lanka.

The React framework, the Vue-electron framework, and node.js were used to develop the "TrainGO" app. Couch DB and the Pouch DB were used as the databases for the development purpose. Marvel App was used to design the App. Therefore, the "TrainGo" app can introduce with a minimal cost that can be affordable to the stakeholders of the system. At present, smartphone usage has increased considerably. Even without training, stakeholders can use the "TrainGO" app.

### References

Brakewood, C., 2014. *Forecasting Mobile Ticketing Adoption on Commuter Rail by Candace Brakewood*. [Online] Available at: [www.scholarcommons.usf.edu/jjpt/vol17/iss1/1](http://www.scholarcommons.usf.edu/jjpt/vol17/iss1/1)

GIRINIVAS, N., 2015. *International Journal of Computer Science and Mobile Computing*. [Online]

Available at: [www.ijcsmc.com/docs/papers/March2015/V413201594.pdf](http://www.ijcsmc.com/docs/papers/March2015/V413201594.pdf)

Kumar, C. & Ram, V., 2013. "IJIREEICE\_ A Monthly Peer reviewed Online Journals,". [Online] Available at: [www.ijireeice.com/wp-content/uploads/2013/03/6b-a-Ram\\_Kumar-train\\_ticketing.pdf](http://www.ijireeice.com/wp-content/uploads/2013/03/6b-a-Ram_Kumar-train_ticketing.pdf)

Maheshwar, V., 2018. *IOSR Journal of Engineering*. [Online] Available at: [www.isorjen.org/Papers/Conf.ICATE-2018?Volume-13/9-33-38.pdf](http://www.isorjen.org/Papers/Conf.ICATE-2018?Volume-13/9-33-38.pdf)

Rouse, M., 2007. *requirements analysis (requirements engineering)*. [Online] Available at: <https://searchsoftwarequality.techtarget.com/definition/requirements-analysis>

Zongjiang, W., 2012. *Railway Online Booking System and Implementation - Science Direct*. [Online] Available at: [www.sciencedirect.com/science/article/pii/S1875389212016155](http://www.sciencedirect.com/science/article/pii/S1875389212016155)

### Acknowledgment

First and foremost, my sincere thanks goes to the Stations Masters and Passengers who provides their requirement during interviews, questionnaires and several meetings. Then, I would like to thank my final project supervisor Ms. Samantha Wickramasinghe and Research Methodology Lecturers, Mr. Sunesh Hettiarachchi for their constant support during the development of the app and developing the paper as Co-Authors.

### Author Biographies



Mr. A. D. Supun Nimesh graduated from the faculty of IT in Horizon Campus in 2020 and developed the "TrainGo" app to fulfill the requirement of the final year project. Currently, he is working as a Junior Custom Officer and involving software development project in part-time basis. Further, he was an awardee of the Deans' List in all four years during my degree program.



Ms. Samantha Wickramasinghe completed my MSc in IT (Cardiff Metropolitan, UK), BIT (UCSC, Sri Lanka). Currently working as a Lecturer in IT at Horizon Campus. She has more than five (5) years of teaching experience in undergraduate degree, final project supervision and twelve years of experience in Quality Assurance in Higher Education. She published twenty papers related to IT and QA. She has the membership of Computer Society of Sri Lanka.



Mr. Sunesh Hettiarachchi has more than 14 years of industry experience in Software Industry including 6 years of managerial experience. He is working as a part-time visiting lecturer and conducting lectures and supervision for undergraduate and postgraduate level. Nearly eight (8) papers related to the Business Management and IT are published at National and International Conferences. Further, he is currently reading for the DBA (Lincoln University College, Malaysia). He is a member of ACS.

## Journal or Book? : The HydroGIS Perspective on Engineering and Computing Debate

RMM Pradeep<sup>1#</sup>, NTS Wijesekera<sup>2</sup>

<sup>1</sup>Senior Lecturer, Faculty of Computing, Kothelawala Defence University, Rathmalana, Sri Lanka

<sup>2</sup>Chairman of the Board of Directors at Construction Industry Development Authority, Ministry of Urban Development, Water Supply and Housing Facilities, Wijerama Mawatha, Colombo 07, Sri Lanka

#pradeep@kdu.ac.lk

**Abstract:** There are numerous opinions and guidelines to select the most suited literature to state of art reviews. Even it brewed the most important articles align with the availed guidelines, some literatures may be providing controversial ideas. Whilst review the literatures' outcomes, the common practice is to assign equal weight to each literature. Eventually, these important controversial ideas conclude as a neutral concept in state-of-art scenario, whilst real is different. The initial discussion with the worldwide academics and professionals found that the novelty of the result and soundness of interpretation needs to be given weight rather than a source of publication. In the case of young students, such qualitative evaluation may direct error-prone conclusions due to less experience. Hence, to handle the controversial factors, novices require an accepted prioritization of sources with credible weights to each. Then, authors attempted to ask for the opinion of the academics from different streams and found there is a contradictory for prioritization. The academics from engineering discipline mostly trusted on books and guidelines whilst computing academics' trust won by index journals.

As the base work of the present work is a multidisciplinary research on HydroGIS framework development, it faced a problem when prioritise the literature sources.

By virtue of the identified possible sources of publications through the collected literature

to the literature review for the work, rationale for each source was developed using the source credibility theory. The rational was evaluated with thirty-four academics & practitioners from different disciplines. Further it gathered their prioritization & weights for each source. Then findings were evaluated with another ten experts and discussed the outcome with three senior academics & practitioners for confirmation.

The present work found that the indexed journal is the most trusted source of information with a weight of 4.32 (out of 5) whilst web documents with least trust (1.49/5). Nevertheless, evaluation and confirmation discussions stressed to utilize a ratio of weights rather than numbered weights.

**Key Words:** Scientific weight of literature, Credibility Theory, HydroGIS, Journals or books?

### Introduction

#### A. Background

Whilst the authors have been developing a HydroGIS tool development framework for urban flood management, it required to identify the factors to be considered in the framework through state of art review.

The majority of higher education institutes are guiding own students to creditable literatures for the academic activities as a common practise. Those guidelines



described different criteria as shown in the Table 1 and it highlights the “author” and “currency” of the literature are sine-quo-none. Then reviewing the availed guideline, it developed a comprehensive literature evaluating criteria as described in earlier work of the authors (Pradeep & Wijsekera, 2019).

*Table 1: Evaluation criteria of a good literature*

Criteria	The source			
	a	b	c	d
Author (reputation on field, affiliation)	x	x	x	x
Publisher (reputation, where, medium, format)	x		x	x
Accuracy (references, citation, peer review, error-free, relevance)	x	x		x
Currency (published date/ date matters?)	x	x	x	x
Coverage (audience, depth of info)	x	x		x
Point of View (bias? Info/ fact/ research outcome/ analysis ?)	x	x		x
Editions/ Revisions (update through time) and Title of the journal			x	

a: OntarioTech Library (2019)      b: Run Run Shaw Library (2019)  
 c: Cornell University Library (2019)      d: Berkeley Library (2019)

Following the developed criteria, it selected the best literatures, but the findings through the literatures were conflicting. Conflicting idea is a common phenomenon, but whilst review outcome, factor-nullifying was occurred. Nevertheless, whilst the confirming the factors with experts, again those nullified factors got prominence. Hence when re-view the literature review criteria, and found that the equal weighting of each literature is as a reason to erroneous.

Then the present work opened a web based discussion (see [https://www.researchgate.net/post/How\\_to\\_weight\\_the\\_literature\\_in\\_Literature\\_review?](https://www.researchgate.net/post/How_to_weight_the_literature_in_Literature_review?)). With participation of senior academics from India, Poland and Malaysia, it found that there is no source weighting mechanism or guideline in practise. Further participants state the better option as the qualitative assessment of the individual articles following a published list of sources from trusted institutes like governments, universities, web of science,

Scopus and so forth. The most senior scientist in the discussion, Roman Bohdan Hołyński (Poland), who is having more than fifty-year research experience, stated that, the novelty of the result and soundness of interpretation need to be given weight rather than source of publication. Even the discussion has given important inputs to the work, it terminated with no guidelines to priorities the literature sources, but added more attribute to the earlier literature evaluating criteria. It is fact that the substantial qualitative assessment needs more exposures and experience which could not expected from novice researcher.

### B. Objective

Then, the objective of the present work is to develop a weighted list of sources to be utilised by novice researches.

## Method and Materials

### A. Identifying the Sources of Literatures

The term “sources of literatures” carries different meanings and utilizations in scholarly works. Specially when the scholars use the “Primary” and “Secondary” adjective to the noun “Source”, conflicting categorisations could have been observed. For an example Saunders & et al (2009) describe a list of primary sources as report, thesis, conference proceeding & government publication whilst secondary sources as books, journals and government publications (Saunders et al., 2009). But this classification, questioning the Cronin et. al.,(2008) definition; the primary sources are any reports by the original researcher (But journal articles are most of the time through the original researchers and Saunders et al., categorised it in the secondary sources). Further secondly sources are describing some other’s work but Saunders et al., categorise “report”, which summarised others’ work, to the primary source (Cronin et al., 2008). However, the both concepts are accurate to the concept and scenario that the

authors are developing. Not only these two but also in other literatures there are numerous categories, groupings, and classifications which leads the novices to more conflicts.

Therefore, the present work decided to limit to the sources of 32 literatures which utilised to state-of-art review and another 23 literatures which utilised in conceptual HydroGIS model building which are earlier works. Then, the present work identified eight sources such as (1) Specific Guideline/Standards (Accepted standard procedures between multi-nations/inter-institutions, legislations, bills, statements and Time-tested industry standards such as European Water Framework Directive (2000) and The Hague Ministerial Declaration (2000)), (2) Book / Book Chapter (Established and recommended books for the subject which published by the prominent authors such as "Applied Hydrology" of Chow, Maidment, & Mays (1988)), (3) Indexed Journal (Journals which are having an impact factor or index value calculated through standard databased like Web of Science, Scopus, and Google Scholar. Example is "IEEE Transactions on Dependable and Secure Computing" with 6.404 impact factor) (4) Peer Reviewed Journal (Journal which are subjected to review its articles using single/double/triple blind review process, but still those were not indexed in standard databases . Example is Elsevier's "Array"), (5) Conference Proceedings (The article published in indexed conferences and/or the such conference's proceedings are being referenced frequently by other prominent researches. Example is HydroGIS96 conference's proceedings which received more than 1000 citations to its articles.) (6) Thesis (The Doctoral, MPhil and research MSc dissertations of higher ranking universities. Example is "Neural-embedded discrete choice models" PhD thesis of Yafei

Han, Massachusetts Institute of Technology), (7) Monograph (A single subject area focused research publications which written after standard critical evaluations by subject experts, but has not published in any of the sources described from 1-6 above. Example is "Urban stormwater hydrology" of D.F. Kibler (1982) at <https://tamug-ir.tdl.org/handle/1969.3/24540>) and (8) Web Document (news/interviews/documents with update or review of the subject which the prominent researches are involved. Example is web documents regarding the usability by Jacob Neilson's, a leading researcher of usability).

#### B. Credibility of Sources

Once it identified the sources which important to study, then it needs to evaluate the credibility of each source. According to the actuarial sciences specialist, Longley-Cook (1950), credibility is a relative weight of one data over other data. This is also known as credibility theory. Present work utilised the concept of relative weight in line with credibility theory to develop a weighted list of literature sources. However, this weighted list need to be implied the belief of the scholars, academics and practitioners of the particular subject. Then, the "data" of credibility theory required to be "trust on source" and "weight of one data over other data" can be defined as "weighted average of trust on a source" as the credibility theory is based on weighted averages (Venter, 2003). For the purpose, the present work attempted to capture the relative trust on given set of sources directly from the experts. However, due to the definitions and experiences are different, the present work needs to provide a common thinking - a rational - to expert before express their idea on literature sources.

Table 2: Conceptual Framework for Rational Building

Source of Literature	Four types of Fogg and Tseng (1999) initial credibility for computing				
	Presumed credibility (logos and pathos) Establishment Level of the idea	Reputed credibility (logos and pathos) How the idea was evaluated	Surface credibility (ethos) Acceptance of publisher	Experienced credibility (logos and pathos) Probability of individual experience with the idea	
Specific Guideline/ standards	Established idea	Panel Reviewed	Reputed publishers	May be or may not. But have seen the application of idea	
Book / Chapter				Probably Very high	
Indexed Journal	Novel idea			A group of people discussed with different perspectives	Probably very low
Peer Reviewed Journal					
Conference Proceedings	Arguable idea	A limited set of people discussed subjectively			
Thesis		Evaluation and Result of the literature itself			
Monograph	Tested only by the presenter	Comments and recommendations by viewers	Varying reputation		
Web Document	General view to Novel idea				

Then when develop a rational, the twentieth century thinking of Aristotle on rhetoric communication grasped the present work's attention due to listeners' trust perception on an idea is based on the source or the person who is presenting (Berlo, Lemert, & Mertz, 1969). Aristotle described three persuasion concerns; logos (the fact or logic of the expression), pathos (interpretation of the facts/the emotion) , and ethos (credibility / legitimacy of the source) (Bade, 2009). This concept has interpreted in different ways in different studies. However, in general view it can be categorised the "source of an article" in to two distinct ways, (1) the author and (2) the place where the literature published. But the present work concern is to weighting the second categorisation - the place where the literature published or the ethos. However, when consider the publisher's credibility based on the viewers' point of view, in can be interpret the remaining two (1) logos - General trust on the accuracy of the literatures published by a particular publisher(source) and (2) pathos -Trust on

the process which the publisher follows to clarify the contents of literature.

The Aristotle's concept was reviewed by Braet (1992) and stated that when the statement (the outcome of the expression) is having on rational judgment and better procedure, the logos play major role in trust building. In other way the pathos and ethos play the major role to make believe the viewers on the fact even does not have a better rational and/or better procedure (Braet, 1992). Therefore, the present work developed a conceptual think which "when evaluate a weight the source of literature, it should consider not only ethos but also pathos and logos".

However, one of the established theory on credibility, the Source Credibility theory, has being developed based on the ethos (Berlo et al., 1969; Hovland & Weiss, 1951). Three dynamics are in source credibility theory. Fogg and Tseng (1999) articulate the "initial credibility", one of source credibility dynamics to the field of computing. They provide four types of credibility for computers (1) Presumed credibility: general trust-assumption in mind (b) Reputed credibility: how third-parties trust on source (c) Surface credibility: trust given by the

appearance of the source and (d) Experienced credibility: own experience with the source (Fogg & Tseng, 1999).

When critically evaluate these four types, the present work observed that those confirm the conceptual thinking of the present work, which is “when evaluate a weight the source of literature, it should consider not only ethos but also pathos and logos”. Therefore, based on the Fogg and Tseng (1999) four types, it developed a conceptual framework for each source as shown in Table 2. Then based on the conceptual framework, it developed a rational as shown in the Table 3.

*Table 3 Rational for different literature sources*

Literature Source	Rational
Specific Guideline/ standards	Established reviewed documents for new technology considered as appropriate for practice
Book / Chapter	Established reviewed knowledge of seasoned knowledge and practice
Indexed Journal	Knowledge that had been thoroughly reviewed.
Peer Reviewed Journal	Knowledge that has been well reviewed
Conference Proceedings	Ideas for discussion of scientific forums which required critical review
Thesis	Similar work evaluated at institutional level and requiring further review
Monograph	Concept which require further review
Web Document	General views and ideas that may have value

### C. Questionnaire Development and Data Collection

Once the rationales for each source were developed, it required to weight the sources parallel with the experts’ trust. A three-questions were formed and 1st question was to capture the qualitative preference of the each rational for sources (used five-point Likert scale from Strongly Agree to Strongly Disagree). This question hopes to fix the readers perception with the source credibility attributes. Then 2nd question was to prioritise the sources (1-8 scale from 1 - highest priority to 8 - least priority). The question’s expectation was to easily

distinguish and prioritise the sources in line with the rational developed in the mind of participants. The third question was to weight the sources (10-1 scale, from 10 – highest weight to 1 – lowest weight). Once the participant comes to this question, his/her mind has a logical argument to give weights. The questionnaire was evaluated for the required purpose with 3 professionals in IT, GIS and Engineering filed.

Then online questionnaire was launched among 1300+ GIS professionals, 72 academics, 34 engineering professionals and 200+ IT professionals from local and foreign institutes and universities.

### D. Data Analysis process

It received 34 successful and complete replies. After combing the data, the weights of the sources were calculated following the weighted average method which implies the normalised weights of the entire sample. The priority of the literature sources was calculated using simple average method. The acceptances of rationales were averaged assigning 1-5 scale value to qualitative scale (1 -Strongly disagree to 5 - strongly agree).

Then the same questionnaire was distributed with another ten experienced academics and practitioners who are senior professors and doctors for the evaluate the findings. The final outcome was discussed with three experts before make conclusions.

## Analysis, Result and Discussion

### A. Data Analysis and Result

The initial and evaluation participants’ academic affiliations and experiences are shown in the Table 4.

*Table 4: Summary of education and experience of the survey sample*

Academic Qual.	Initial data collection		Evaluation		Total	
	No1	Avg2	No1	Avg2	No1	Avg2
BSc	9	4.00	-	-	9	4.00
MPhil /MSc	7	16.43	4	19.25	11	17.45
PhD	14	22.36	2	25.00	16	22.65
Professor	4	37.50	4	40.50	8	39.00
Total and average	34	18.5	10	28.90	44	20.52

<sup>1</sup>Number of Participants

<sup>2</sup>Average experience (Years)

The comparison of the averages of priorities, order of priorities and calculated weights of the sources between initial data collection and evaluation are shown in the Table 5.

Table 6 shows the final priority and weights which resulted after the evaluation of all 44 participants' opinions.

The comparison of rational acceptance for initial data collection and evaluation are shown in the Table 7.

*Table 5: Breakdown summary of initial and evaluation data collection*

Literature source	Initial data collection			Evaluation			
	A <sup>1</sup>	P <sub>2</sub>	W <sup>3</sup>	A <sup>1</sup>	P <sub>2</sub>	W <sup>3</sup>	PC <sup>4</sup>
Indexed Journal	2.4	1	4.27	2.0	1	4.50	5%
Peer Reviewed Journal	2.4	1	3.69	2.3	3↓	3.95	5%
Specific Guideline / standards	2.8	3	3.22	2.0	1↑	3.90	14%
Book / Chapter	3.0	4	3.98	2.6	4	4.40	8%
Conference Proceedings	4.3	5	2.41	5.8	6↓	2.75	7%
Thesis	4.3	5	2.25	4.7	7↓	2.90	13%
Monograph	4.9	7	2.39	5.4	5↑	2.95	11%
Web Document	6.2	8	1.44	7.4	8	1.65	4%

<sup>1</sup>Average Priority score <sup>2</sup>Priority level <sup>3</sup>Weight (out of 5)

<sup>4</sup>Weight Percentage Change based on max weight (5)

Both, the initial and evaluation results for the averages for rational acceptances were received the "Agree" preference (Average value 4.0 in Table 7). This denotes the rational for the sources were accepted and confirmed by the experts. Further it demonstrates the applicability of Fogg and Tseng (1999) four types of initial source credibility theory and Aristotele's logos-pathos-ethos notion to formulate conceptual framework for rational building.

*Table 6: Final literature source priorities and weights of the survey*

	Priority		Final Average Weight (out of 5)
	Average	Order	
Indexed Journal	2.33	1	4.32
Peer Reviewed Journal	2.37	2	3.75
Specific Guide/ standards	2.57	3	3.38
Book / Chapter	2.91	4	4.08
Conference Proceedings	4.64	6	2.49
Thesis	4.42	5	2.40
Monograph	5.02	7	2.52
Web Document	6.47	8	1.49

*Table 7: Acceptance of the rational for trust on literature sources*

Literature source	Average Acceptance (1-5 scale) *	
	Initial data collection	Evaluation
Specific Guideline/ standards	4.0	4.3
Book / Chapter	3.9	4.2
Indexed Journal	4.3	3.8
Peer Reviewed Journal	4.4	4.3
Conference Proceedings	3.8	4.0
Thesis	3.6	3.7
Monograph	4.0	3.8
Web Document	3.8	3.7
Average	4.0	4.0

\* 1- Strongly Disagree, 2- Disagree, 3- Neither, 4 – Agree, 5 – Strongly Agree

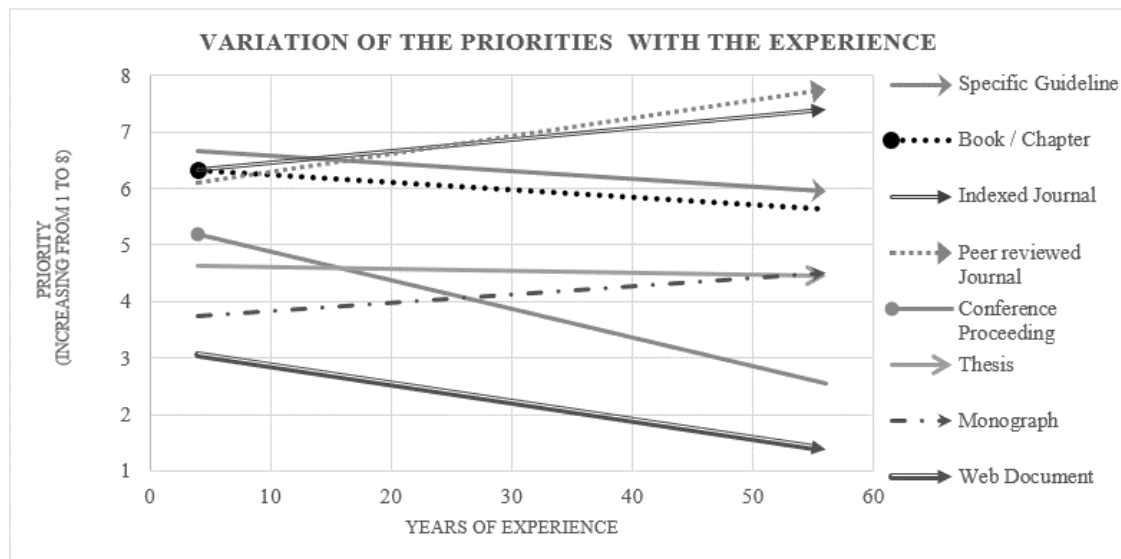

Figure 1: Influence of experience on the prioritization of literature sources

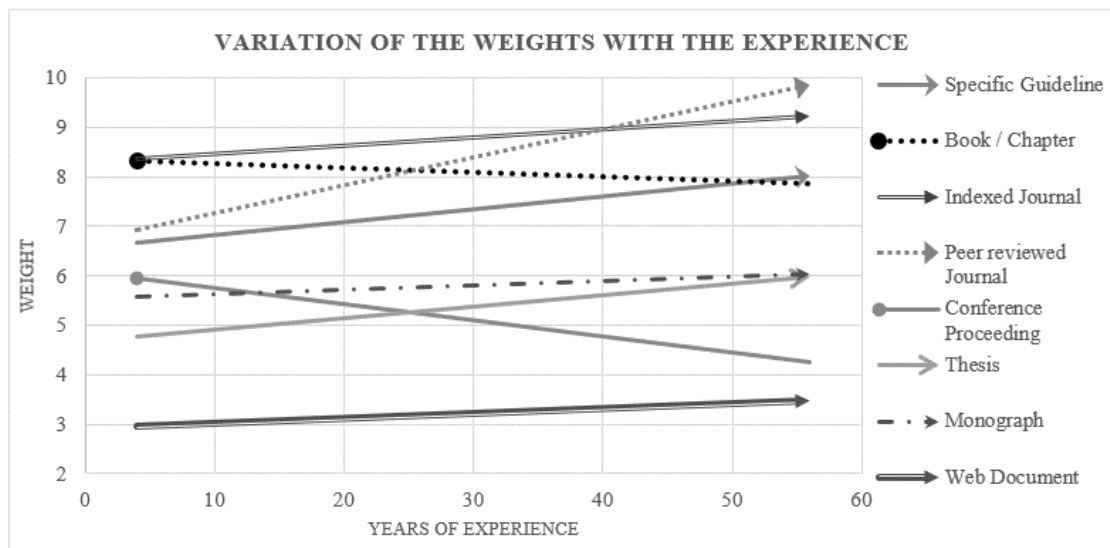

Figure 2: Influence of experience over the trust on literature sources

When prioritising the sources, the present work found that the indexed journal and peer reviewed journal receive the higher priority whilst web document gets the lowest. These two positions are confirmed at the evaluation, but other sources' priorities were not.

Then, it reviewed the data set and found that the "prioritization thinking" is having a relation with the relative experience of individuals (Figure 1).

Further, when compare and evaluate the given weights to each source, it observed a

less prominent variations of the weights between initial and evaluation outcomes (See table 5). Even though the weights are number-wise increased with the evaluators' perception, the order of the weights has been not changed except conference proceeding. The evaluators weight the conference proceedings less than monograph. Then with understanding of prioritization relation with experience, it captured the same variation of the concern on the literature weight too (Figure 2).

Then there are two fundamental observations.

(1) With more exposure to the research and practises, the academics and practitioners are frequently looking at the indexed/peer reviewed journals whilst losing the attention to conference proceedings and web documents. However, the specific standards, thesis, books and monographs remain in the same important throughout the career.

(2) Under the same condition of 1st observation; the practitioners and academics started to believe the contents of the specific guidelines, thesis, and peer reviewed journals. Further it is elegant that the trust on index journal and web document are slightly increasing whilst collapsing of trust on conference proceeding even it got the priority. However, the books and monographs remain in their trustworthiness.

#### B. Expert discussion

These outcomes were subjected to discussion with three senior academics who are having more than forty years of academic and practical experience. Their explanations could be grouped in to three major concerns on literatures; the novelty of an idea, own experience with an idea and accuracy confirmation process of idea. The novelty of an idea will not depend the source where it published but the idea should be inspired a new way of thinking in the reader's mind. Then the attention goes web documents as those contains not only author's idea but also the readers' views in the comment sections. If idea given by the literature is time-tested practise or assisting such practise, again the reader gives more weight to such sources. The time tested monographs, subject specific standard books which recommended by the experts and standard & procedures practised for long time are receiving more attention whilst state-of-art reviews. The speciality of this type of literature is, those were referenced by many researchers since long time. The method of evaluation which is practised by the literature source implies the accuracy confirmation of the idea; with

arguments on the process due to their own experience, the experts indicate that they mostly trust the indexed and peer reviewed journals as those are thoroughly evaluated by the subject specialist than the thesis and conference papers.

Then the views of the experts confirmed the weights and those sequence; (1) the higher weights (varying from 3.38 to 4.42) found for Indexed Journal, Peer Reviewed Journal, Specific Guideline / standards and Book / Chapter, (2) the average weights (2.40 to 2.52) found for Conference Proceedings, Thesis and Monograph and (3) the lowest weight (1.49) found for web document; through this study. Finally it could calculate the ratio based on the group averages as 39 : 25 : 15 between (1):(2):(3) above.

#### Who won the Engineering and Computing Debate on Journals or Books?

In nut shell the present research attempted to find a cross disciplinary accepted weights on different literature sources. However, it is important to share the discipline oriented findings. Therefore, it reviewed the collected data and selected the best 33 professionals from three disciplines (1) Engineering (with maths and medicine) (2) Computing and (3) Geography. Figure 3 shows the different disciplines' interests. Interestingly, the well-established research discipline like engineering and medicine equally trust on Books, guidelines and indexed journal papers relatively. The emerging computer discipline which is having dynamic findings frequently believe the peer review and indexed journals. However, the geography experts seek the knowledge with diversified attitude on monographs. It is worth to note that, these findings are only a guideline for further research as it required more extended sample size from each discipline to come to a conclusion.

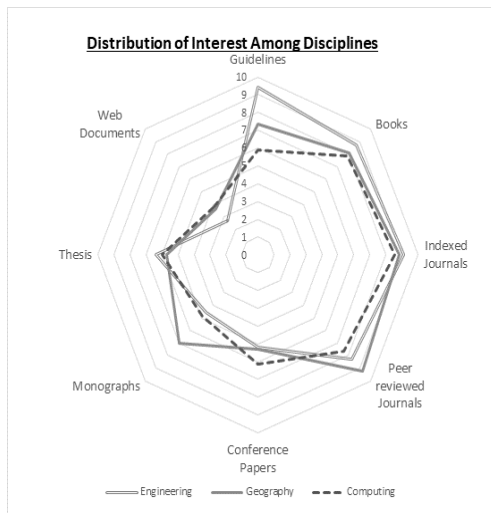

Figure 3: different Disciplines' Interest Distribution

## Conclusion

The present work attempted to find weights for eight type of literature sources. By developing and confirming a rational for the trust on literature sources, it demonstrated the successful utilization of Initial Source Credibility Theory and Aristotle's ethos-pathos-logos concept for the work.

Present work found weighted numbers for the literature sources through the views of 44 experienced professionals and academics who are having 20 years' average experience. According to the finding the highest weight (4.32 out of 5) was received by the indexed journals whilst the lowest by web documents (1.49/5).

After the expert discussion, it found that calculating an exact weight for the sources is not justifiable. Nonetheless it concluded that more justifiable weight ratio among the literature sources as 39:25:15 which 39 for Indexed Journal, Peer Reviewed Journal, Specific Guideline / standards, Book / Chapter, 25 for Conference Proceedings, Thesis, Monograph and 15 to Web document.

The expert discussion inspired a different thinking on the classification of the literatures under three concerns which based on the idea expressed by the literature, i.e. Novelty, Experience and Accuracy. As no

critical study has being carried out on these concerns, it needs the attention of the future researchers.

## Acknowledgment

The authors pay their gratitude to the academics, experts and practitioners who contribute their valuable time for the survey as well as private and public electronic and physical discussions. Except their contribution there is no research.

## References

- Bade, D., 2009. Ethos, logos, pathos or sender, message, receiver?: A problematological rhetoric for information technologies. *Cataloging and Classification Quarterly*, 47 (7), 612–630.
- Berkeley Library, 2019. Evaluating resources [online]. *Library Guides*. Available from: <https://guides.lib.berkeley.edu/evaluating-resources> [Accessed 13 Oct 2019].
- Berlo, D.K., Lemert, J.B., and Mertz, R.J., 1969. Dimensions for Evaluating the Acceptability of Message Sources. *Public Opinion Quarterly*, 33 (4), 563–576.
- Braet, A.C., 1992. Ethos, pathos and logos in Aristotle's Rhetoric: A re-examination. *Argumentation*, 6 (3), 307–320.
- Chow, V. Te, Maidment, D.R., and Mays, L.W., 1988. *Applied Hydrology*. Internatio. McGraw-Hill.
- Cornell University Library, 2019. Critical Appraisal and Analysis Critically [online]. *Critically Analyzing Information Sources*. Available from: <http://guides.library.cornell.edu/criticallyanalyzing> [Accessed 13 Oct 2019].
- Cronin, P., Ryan, F., and Coughlan, M., 2008. Undertaking a literature review: a step-by-step approach. *British Journal of Nursing*, 17 (1), 38–43.
- European Water Framework Directive, 2000. Directive 2000/60/EC of the European Parliament and of the Council - establishing a framework for Community action in the field of water policy. *Official Journal of the European Parliament*, L327 (September 1996), 1–82.



Fogg, B.J. and Tseng, H., 1999. The elements of computer credibility. *Conference on Human Factors in Computing Systems - Proceedings*, (May), 80–87.

Hovland, C.I. and Weiss, W., 1951. The Influence of Source Credibility on Communication Effectiveness. *Public Opinion Quarterly*, 15 (4), 635–650.

OntarioTech Library, 2019. Evaluate Sources [online]. *Literature Review*. Available from: <https://guides.library.uoit.ca/literaturereview/evaluate-sources> [Accessed 13 Oct 2019].

Pradeep, R.M.M. and Wijesekera, N.T.S., 2019. Literature Evaluation Criteria [online]. *Publication*. Available from: [https://www.researchgate.net/publication/338228064\\_Proposed\\_Literature\\_Weighting\\_Method](https://www.researchgate.net/publication/338228064_Proposed_Literature_Weighting_Method) [Accessed 18 Jun 2020].

Run Run Shaw Library, 2019. Evaluating Sources [online]. *Literature Review - Finding the Resources*. Available from: <https://libguides.library.cityu.edu.hk/litreview/evaluating-sources> [Accessed 13 Oct 2019].

Saunders, M., Lewis, P., and Thornhill, A., 2009. *Research Methods for Business Students*. Fifth. Prentice Hall. Harlow: Pearson Education Limited.

The Hague Ministerial Declaration, 2000. Ministerial Declaration of The Hague on Water Security in the 21st Century. *World Water*, 1–3.

Venter, G., 2003. Credibility Theory for Dummies. *CAS E-Forum*, 621–628.

### Author Biographies



RMM Pradeep is a Commissioned officer of Sri Lanka Army where he has been a senior lecturer since 2015 in Faculty of Computing, General Sir

John Kothelawala Defence University. His research interests lie in the area of HydroGIS framework, System analysis and design and software modelling & processing. Pradeep has served on roughly twenty-three years in different assignments in arbovirus vector research, military IT resource management and Computing and Geoinformatics research.



NT Sohan Wijesekera is a senior professor (Civil engineering) in University of Moratuwa. He is an elegant

hydrologist who won the Presidential CVCD Award for his research contribution. Snr Prof Sohan has been served more than forty-one years in the national water resource management industry and teaching in the university. He supervised more than 60 post graduate researches including PhDs. Presently he serves as the Chairman of the Board of Directors, Construction Industry Development Authority, Sri Lanka.

## Use of Security Culture to Contribute on Enterprise Information Security for the Small and Medium Scale Enterprises (SMEs)

HPAI Pathirana

No 100, Kandawala Road, Ratmalana, Sri Lanka  
asanka.pathirana@gmail.com

**Abstract:** The great use of technologies and flexible work environment introduce complex scenarios to consider for enterprises to assure Enterprise Information Security (EIS). Further the success/failure of EIS effectively rely on behaviour of stakeholders of an enterprise irrespective to the available comprehensive enough technical infrastructure. Therefore, the Security Culture (SC) is recommended to implement at the initial phase to reduce the risk of unacceptable behaviour of stakeholders. Moreover, the SC is further important for Small and Medium Enterprises (SMEs), because comprehensive technical implementation to assure information security is not affordable with limited budget, resources and technical staff. The SC can be introduced as iterative process which must start from somewhere based on primary considerations and improve as required through multiple iterations to fulfil EIS need. The frequent evolvement of SC is essential to address consequences of technological development. The SC can be introduced as sub culture of organisation culture, because each stakeholder of the enterprise has active part on assuring EIS in their regular tasks. The mature SC delivers the understand of importance of assuring information security, individual responsibility in security aspects which is way over the general organisational culture, as people is the weakest(only link) for EIS(the technology). Further, people is the first line of defence in any attack, so they must be aware and prepared to represent

“Human Firewall”. As a result, analyzing assets, analyzing threats, analyzing vulnerabilities, risk assessment, standards and framework, policies and procedures, responsibility, maintenance, stakeholder awareness aspects should be prioritized for implementing SC. Nevertheless, the effective ways to deliver awareness among stakeholders within a SME for enterprise security management should be identified. The successful implementation of SC contributes to EIS for SME effectively.

**Key Words:** Security Culture, EIS, SME, Vulnerabilities, Threats, Human Firewall,

### Introduction

The Enterprise Information Security (EIS) is a problem of people, and it is not just a problem of technology, because people implements and maintains the technological environment(Waly, Tassabehji, & Kamala, 2012). Nevertheless, technology is tool to either use or misuse by the people. The 2%~3% of annual profit of an enterprise is potentially lost due to the poor EIS, nevertheless it influences on reputation of an enterprise having bad impression on customers(Buckley, Nurse, Legg, Goldsmith, & Creese, 2014). Unfortunately, the insider has intentionally/unintentionally involved in most of the incidents, and many studies have same conclusion of the negative involvement of insiders (Buckley et al., 2014; da Veiga & Eloff, 2010; Furnell & Clarke, 2005). Considering those aspects, the enterprises is essential to focus on cultivating understand among stakeholders against the complex uncertain and dynamic characteristics of

insider. Consequently, the Security Culture (SC) is the overlap of needs of organisation culture and EIS as shown in Figure 1, which illustrates SC is part of organisation culture focusing behaviour of stakeholders while contributing to EIS.

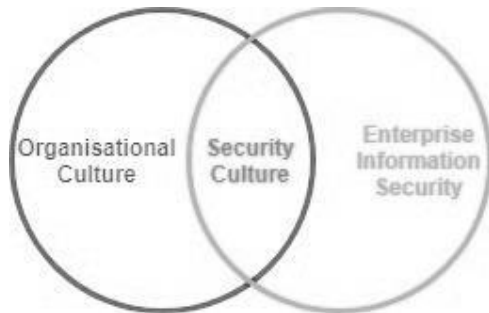

Figure 2: Representation of Security Culture  
Source: Author

The enterprise uses interconnected technologies to fulfil business needs effectively in an enhanced level to compete among the competitors, because the business process is significantly influenced with the evolution of technologies(Dhillon, Syed, & Pedron, 2016). As a result, employee is not essential to come to the office regular basis, and customer is served either remotely or in their premises for example. Moreover, many flexible innovative initiatives are introduced with technological enhancement. So the information security is a prior consideration for enterprise at the start-up(Alnatheer, 2015; Dhillon et al., 2016). However there is no enough attention on assuring information security at most of the time, and it introduces challenges to continue business in return(Waly et al., 2012). Assuring information security is global problem for the businesses.

The implementation of technologies and relevant procedures purely contribute to EIS, however large number of incidences are introduced by stakeholders of enterprise due to the negligence or poor knowledge(Dhillon et al., 2016). A one way of defining information security culture is “The collection of perceptions, attitudes, values, assumptions, and knowledge that guide the

human interaction with information assets in [an] organization with the aim of influencing employees’ security behaviour to preserve information security”(AlHogail, 2015). Although, the stakeholders represents as the weakest link in the field of EIS by some researchers(da Veiga & Martins, 2017; Sarkar, 2010), the effective implementation of security culture leads for stakeholders to behave as human firewall, since stakeholders do not allow to breach security requirements(Alfawaz, Nelson, & Mohannak, 2010). It is essential to convince stakeholder about the importance of secure behaviour in both work life and personal life through effective implementation of SC.

The most of large scale enterprises maintain better technical implementation adequately by recruiting relevant technical skill staff, because there is no budget constraints, however Small and Medium Enterprises(SMEs) experience in challenges on finance, staffing factors to implement and maintain technical infrastructure(Williams & Manheke, 2010). More often, SMEs consider that information security is not a challenge for them, because they are small, and they rely only on implicit work ethics and trust(Lim, Chang, Maynard, & Ahmad, 2009). Nevertheless, limited staff is responsible for many task which introduces shared resource environment. This research paper is organised to convince SMEs about the importance of assuring EIS and to introduce them effective techniques to implement an SC with priority in their operational environment.

### Background

The enterprise security management is evolution process assuring the information security(Waly et al., 2012). The assets are prioritised considering the business value of them to identify what is essential to be

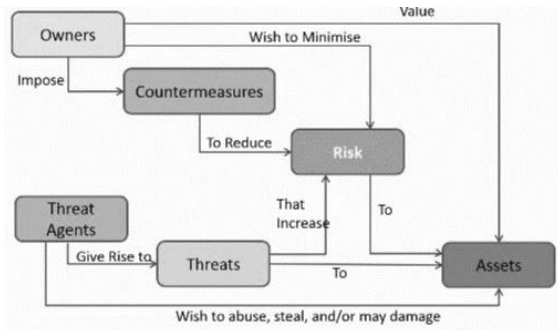

Figure 2: Enterprise Security Management Ecosystem  
 Source: de Vries, 2016

protected, and risk assessment conducts to identify the risk by introducing countermeasures to reduce the likelihood of exploiting threats (Nasir, Arshah, & Ab Hamid, 2017). Further, financial commitment for a countermeasure must be lesser than the losses against the information security breaches. An enterprise security management ecosystem is shown in the Figure 2 illustrating causalities among different entities (de Vries, 2016). The SC is a cost effective countermeasure correcting behaviour of people, so the SC is important to consider at the start-up.

#### A. Technology and People

Information represents both the hard copies and data in the systems, and people access information in for ways; directly, through systems, over networks and the Internet. A foundation for the security framework is in the Figure 3; sphere of security (Whitman & Mattord, 2011), and the possible countermeasures are illustrated in both technology and people aspects. Nevertheless, contingency planning is essential for addressing security consequences; Incident Recovery, Disaster Recovery, Business Continuity. The evolving technology is a threat for available technological implementation of an enterprise to assure information security (Waly et al., 2012), so it is necessary to acknowledge the stakeholders through effective implementation of SC as describe at next.

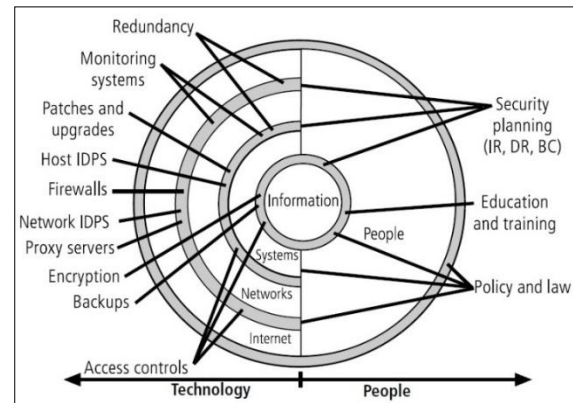

Figure 3. Sphere of Security  
 Source: Whitman & Mattord, 2011

#### B. Human Factors

The possible human factors have been identified affecting negatively on EIS, and those are not able to address via technical implementation, where security culture is vital important. Human factors are listed as finding of the literature with the relevant description (Ashenden, 2008; Buckley et al., 2014; da Veiga & Martins, 2017; Nasir et al., 2017; Sarkar, 2010).

- 1) Improper Use of Password: Share password, write down password, repeat password are rely on human nature, however use of poor password must be addressed over password policy.
- 2) Forget to Logout of Systems: The stakeholders are responsible for logging out from the systems after use, however technical configuration is allowed on automatic log out within short time.
- 3) Theft /Lost of devices: The portable devices; smart phone, laptop, tablet, are not in control of physical security. Consumer must protect the device with priority.
- 4) Insecure storage: The storage spaces; physical and electronic, must not be accessible for unauthorised stakeholders due to any reason.
- 5) Insecure Disposal and Reuse: The hard copies of sensitive data; customer details for example, might be used for wrapping something, moreover old laptop might be

sold without deleting data in hard disk. Nevertheless there are techniques to recover deleted data from digital storage. These aspects must be considered closely before dispose or reuse.

6) Resource Misuse: Technologies may be misused in BYOT support; share devices, open WiFi access for convenience for example.

7) Compromise Contractor: The contractor for specific work must be dealt in separate way as untrusted stakeholder by not allowing privileged access to sensitive data.

8) Ignorance of Popup System Warning: The technical implementation to acknowledge stakeholders is available, but stakeholders are not considered them due to poor understand.

9) Accepting Spam Email: The spam email is able to filter technically, however there may be spams rarely, so human firewall must be capable to differentiate them accordingly.

### C. The SC Implementation

The implementing EIS is a challenge for most of the enterprises due to the financial, time and staffing factors for example (da Veiga & Martins, 2017), further the SMEs penalised in various manner due to those aspects having limited resources compared to large enterprises (Ng, Ahmad, & Maynard, 2013; Williams & Manheke, 2010). The effective implementation of SC is best possible solution for SMEs with adequate level of policies and technologies implementation as per enterprise requirements after the proper risk assessment (Alnatheer, 2015). nevertheless stakeholders must be acknowledged about the importance of assuring information security adequately as significant part of SC (Furnell & Clarke, 2005).

1) Risk Assessment: The risk assessment goes first in any secure implementation to evaluate the available assets, possible threats/vulnerabilities (Alnatheer, 2015;

Nasir et al., 2017), because the critical assets are essential to treat with priority against highly influencing threats/vulnerabilities in affordable manner. Further, the high level risks must be addressed, but medium risks can be transferred by having insurance for example (Whitman & Mattord, 2011). Nevertheless some risks are accepted, since the cost to address that is higher than the impact due to the breaches. Further, some risk can be ignored considering the minor potential impact.

The SMEs are essential to conduct risk assessment at first. Although there are technical implementations are available as countermeasures, SMEs are important to consider implementing effective SC as most effective countermeasure for assuring EIS.

2) Policy Needs Addressing SC for EIS: The enterprise wide information security policy document is essential to introduce in enterprise security management (Furnell & Clarke, 2005; Waly et al., 2012), further implementation of ISO/IEC 27002 to fulfil information security need introduces common language globally (Disterer, 2013). Policy addresses both technical and non-technical implementation requirements of EIS, but this paper focus is about non-technical implementation for effective SC. The primary policy would be focusing on behaviour of stakeholders to introduce best practices; user policy which address the different group of people incorporate with enterprise as stakeholders (Buckley et al., 2014), and it is included with legislation requirement in the event of misconduct. Further the scope of policy depends on enterprise needs, and procedures are introduced based on policy for operational environment.

For example, BYOD is increasing demand of stakeholders due to the comfortable work environment (Miller, Voas, & Hurlburt, 2012), however it allows many vulnerabilities to appear, if there is no extra attention on

devices. It is further expanded into Bring Your Own Technology (BYOT) (Miller et al., 2012). BYOT policy introduces required attention in the use of them addressing the security issues; migration of malware into company network, migration of sensitive data into personal devices, open up security holes, physical security, and the privacy issues; leak of company confidential information, customer personal information.

3) Awareness of Stakeholders: The implementation of technology and policy is effective on active contribution of the stakeholders with better awareness (Furnell & Clarke, 2005; Waly et al., 2012). The requirement for EIS must be known to the stakeholders adequately, and the objective of awareness, training and education programs are conducted to deliver required information/knowledge/insight in theory (Whitman & Mattord, 2011). The awareness program focus on immediate needs on what/things to follow by delivering relevant information for exposure through interactive media, whereas training program focus on average needs on how/approaches to follow by delivering relevant knowledge for skill through hands-on experiences. Nevertheless the education program focus on strategic long term objectives on why/reasons to follow by imparting relevant insight for understanding through theoretical understand. However, specific needs of SME utilise available approaches to deliver proper awareness among stakeholders (Ng et al., 2013).

### Methodology

This research is a review and an analysis based on available literature relevant to the SC to find out effective implementation the SC. Both technology and people aspects are evaluated to emphasis enterprise security requirement in background study. Then SC implementation techniques are analysed in different aspects, and the contribution of

successful implementation of SC is considered to EIS for SMEs at the end.

#### A. Research Design

The research design has been introduced based on methodology, and this research follows qualitative approach based on available literature. The motivation of this research to address the global problem to EIS for SMEs by analysing available approaches to implement SC.

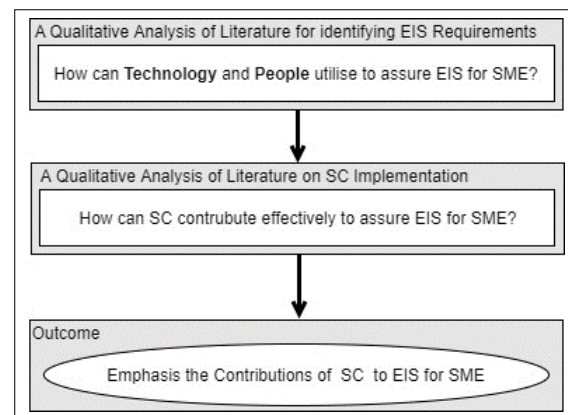

Figure 4: Research Design  
Source: Author

### Results

The EIS focuses information security needs in an enterprise, and it is supported by security policy as per strategic plan. The SC is significant branch of that considering the complexity of involvement of human. The risk assessment is a main attempt to identify the required technical implementation and other requirements as countermeasure to assure the EIS, and the primary focus of SME is implementation of the SC as countermeasure. The available standards and frameworks assist on developing enterprise specific plan to implement the SC. The budget is a major constrain for SMEs. The SC requirements are primarily addressed through policies and procedures, and the legislation requirements are also enforced. The responsibilities are assigned

Table 1: Research Paper Findings

Paper	Contributing Aspects										Awareness Delivery Approaches									
	Analysing Assets	Analysing Threats	Analysing Vulnerabilities	Risk Assessment	Standards and Frameworks	Policies and Procedures	Responsibility	Maintenance	Stakeholder Awareness	Videos	Posters	Leaflets/ News Letters	Employee Agreements	Self-Studies	Punishments and Rewards	Lectures/ Workshops	Courses	Hands on Practices	Assessments and Reports	
(Furnell & Clarke, 2005)					x	x	x	x	x		x	x	x	x		x	x	x	x	
(Ashenden, 2008)				x	x	x	x	x											x	
(Lim et al., 2009)					x	x	x	x	x				x	x	x	x		x	x	
(Alfawaz et al., 2010)		x	x				x	x												
(Da Veiga & Eloff, 2010)				x	x	x	x													
(Sarkar, 2010)	x	x	x	x	x	x	x	x	x				x	x	x				x	
(Whitman & Mattord, 2011)	x	x	x	x	x	x	x	x	x	x	x	x	x	x	x	x	x	x	x	
(Waly et al., 2012)		x	x	x			x	x											x	
(Disterer, 2013)	x	x	x	x	x	x	x	x	x				x					x	x	
(Buckley et al., 2014)					x	x	x													
(AlHogail, 2015)				x	x	x	x													
(Alnathier, 2015)	x	x	x	x			x	x					x					x		
(Dhillon et al., 2016)					x	x	x	x							x				x	
(da Veiga & Martins, 2017)	x			x	x	x	x	x	x		x	x	x	x	x	x	x	x	x	
(Nasir et al., 2017)				x	x	x	x	x	x											

explicitly, and it is essential to maintain expected level of SC appropriately. The implementation of security measures is further effective with the appropriate awareness of stakeholders though effective awareness programs. Many researchers have discussed on those as indicated in Table 1.

A) Aspects of effective security culture implementaion

The findings in Table 1 are evaluated further for introducing the better understand of influence of different aspects.

- 1) Analysing Assets: The available assets must be prioritised through thorough analysis to treat for information security.
- 2) Analysing Threats: The significance of possible threat decides the requirement of secure implementation.
- 3) Analysing Vulnerabilities: The significance of available vulnerabilities decides the requirement of secure implementation.
- 4) Risk Assessment: Risk assessment is comprehensive process to finalise the need of implementing countermeasures as fact findings.
- 5) Standards and Frameworks: It is not necessary to start from outset, because available standards and frameworks

guides need of SC in effective manner. Many SME do not focus on them.

- 6) Budget: Budget is a major concern of SMEs, as EIS is not part of main business process. The countermeasure implementation must not exceed the lost due to security breaches.
- 7) Policies and Procedures: The policies provide the guidelines, and procedures are introduced to cultivate best practices for behaviour of the stakeholder. Law enforcement must be addressed.
- 8) Responsibility: Each stakeholder has an active part to play for effective SC implementation. The legislation, rewards and punishments are explicitly disclosed though an agreement for extra attention. Further, report on any incident is one common responsibility.
- 9) Maintenance: The present mature implementation becomes obsolete at next moment with evolving technology, so it is essential to conduct periodic audit for maintenance.
- 10) Stakeholders Awareness: The effective awareness program is essential to convey the need of assuring information security in understandable way. It is essential to focus on individuals.

B) Approaches to deliver the stakeholders awareness

There are 10 approaches listed here to deliver awareness effectively among the stakeholders.

- 1) Videos: The videos explain important scenarios in effective manner.
- 2) Posters: Poster can be displayed in common area with graphical contents to understand easily.
- 3) Leaflets/ News Letters: A unique concern is acknowledged to the stakeholders, and graphics may help to understand the problem.
- 4) Employee Agreements: The employee agreement is addressed a legal point, so it becomes part of the job role and responsibilities.
- 5) Self-Studies: The relevant news articles, online publications about real time scenarios are shared among stakeholders to emphasis the significance of EIS.
- 6) Punishments and Rewards: This motivates the stakeholder not contribution on security breaches, since it is personally addressed.
- 7) Lectures/ Workshops: Lecture is organised deliver theoretical knowledge, whereas workshop may focus on case study.
- 8) Courses: The long term security objectives are addressed educating technical staff for implementing and maintaining secure systems.
- 9) Hands on Practices: The training sessions guides how to interact with technology in practice through hands on experience.
- 10) Assessments and Reports: The periodic approach to evaluate stakeholders is recommended to

have some understanding of them and report accordingly.

### Discussion

A SME has unique challenges to focus on something else in addition to main business process, so they consider EIS as acceptable risk for them assuming no one interest on their information. This research focuses on contribution of SC to EIS for SME as cost effective approach as motivation for SMEs. As initiatives, some aspects are easy to implement with the fundamental approaches since the limited stakeholders in a SME, but continuing the iterative approach towards the successful implementation of EIS is a challenge due to fair reasons attached with finance. This is all about affordability of SME, but it may not the poor interest to assure EIS.

The 10 aspects have been identified in this research serious consideration in SC implementation analysing available literature, and the importance of considering those is also disclosed in broad sense having general understand of SMEs. Nevertheless, 10 approaches are listed with the relevant description to deliver awareness among stakeholders, because the SC is able to establish effectively in operational environment with the awareness of stakeholders improving perceptions, attitudes, values, assumptions, and knowledge of stakeholders.

This paper is about contribution of SC to EIS for SME in general. However there are different sectors of enterprises like education, medical, sales, food, agriculture, production for example(Bolek, Látecková, Romanová, & Korcek, 2016; Gebrasilase & Lessa, 2011; Sari & Nurshabrina, 2016), and certain aspects are emphasised in one sector whereas those are not important for another sector. It is essential to continue this study focusing different sectors in future researches.



## Conclusion

The technology implementation to assure the EIS can be established as per the essential requirements of a SME, but mature technical implementation to assure the EIS is not affordable for SMEs in general. The best approach would be dealing with technology in secure manner without introducing vulnerabilities and without allowing threats to exploit. As a result, the SC is the appropriate solution to address human factors instead of technical factors. The SC must be strategically adopted into the operational environment as part of organisation culture to rely on behaviour of stakeholders. Further, the active contribution of each stakeholder is utterly important to achieve this goal, so everyone must have better understand on their responsibilities.

The 10 aspects to consider in effective implementation of SC and the 10 approaches to deliver awareness of stakeholders are tool for implementing mature level of SC. The SC promotes via values, knowledge, artefacts and assumptions relevant to information security, and it is effective if stakeholders act accordingly against any negative incidents according with better understand. Finally, this research filled the gap of the poor understanding of SC implementation by critically evaluating available literature for effective implementation.

The effective implementation of the SC guarantees on addressing information security breaches without introducing vulnerabilities, nevertheless “Human Firewall” is extremely strong enough to prevent from exploiting newly introduced threats which are still not addressed technically. The future work focuses adding value on present findings considering the nature of enterprise due to the unique EIS requirements among them.

## References

- Alfawaz, S., Nelson, K., & Mohannak, K. (2010). Information security culture: a behaviour compliance conceptual framework. Paper presented at the Proceedings of the Eighth Australasian Conference on Information Security-Volume 105.
- AlHogail, A. (2015). Design and validation of information security culture framework. *Computers in human behavior*, 49, 567-575.
- Alnatheer, M. A. (2015). Information security culture critical success factors. Paper presented at the Information Technology-New Generations (ITNG), 2015 12th International Conference on.
- Ashenden, D. (2008). Information security management: A human challenge? *Information security technical report*, 13(4), 195-201.
- Bolek, V., Látecková, A., Romanová, A., & Korcek, F. (2016). Factors Affecting Information Security Focused on SME and Agricultural Enterprises. *AGRIS on-line Papers in Economics and Informatics*, 8(4), 37.
- Buckley, O., Nurse, J. R., Legg, P. A., Goldsmith, M., & Creese, S. (2014). Reflecting on the ability of enterprise security policy to address accidental insider threat. Paper presented at the Socio-Technical Aspects in Security and Trust (STAST), 2014 Workshop on.
- da Veiga, A., & Eloff, J. H. (2010). A framework and assessment instrument for information security culture. *Computers & Security*, 29(2), 196-207.
- da Veiga, A., & Martins, N. (2017). Defining and identifying dominant information security cultures and subcultures. *Computers & Security*, 70, 72-94.
- de Vries, D. (2016). COMP 9721 - Enterprise Information Security - Topic Manual. Flinders Learning Online (FLO): Flinders University.
- Dhillon, G., Syed, R., & Pedron, C. (2016). Interpreting information security culture: an organizational transformation case study. *Computers & Security*, 56, 63-69.
- Disterer, G. (2013). ISO/IEC 27000, 27001 and 27002 for information security management. *Journal of Information Security*, 4(02), 92.

Furnell, S., & Clarke, N. (2005). Organisational security culture: embedding security awareness, education and training. *Computer Security Journal*, 21(3), 12.

Gebrasilase, T., & Lessa, L. F. (2011). Information security culture in public hospitals: the case of Hawassa referral hospital. *The African Journal of Information Systems*, 3(3), 1.

Lim, J. S., Chang, S., Maynard, S., & Ahmad, A. (2009). Exploring the relationship between organizational culture and information security culture. Paper presented at the Australian information security management conference.

Miller, K. W., Voas, J., & Hurlburt, G. F. (2012). BYOD: Security and privacy considerations. *IT Professional*, 14(5), 53-55.

Nasir, A., Arshah, R. A., & Ab Hamid, M. R. (2017). Information Security Policy Compliance Behavior Based on Comprehensive Dimensions of Information Security Culture: A Conceptual Framework. Paper presented at the Proceedings of the 2017 International Conference on Information System and Data Mining.

Ng, Z. X., Ahmad, A., & Maynard, S. B. (2013). Information security management: Factors that influence security investments in SMES.

Sari, P. K., & Nurshabrina, N. (2016). Factor analysis on information security management in higher education institutions. Paper presented at the Cyber and IT Service Management, International Conference on.

Sarkar, K. R. (2010). Assessing insider threats to information security using technical, behavioural

and organisational measures. *Information security technical report*, 15(3), 112-133.

Waly, N., Tassabehji, R., & Kamala, M. (2012). Improving organisational information security management: The impact of training and awareness. Paper presented at the High Performance Computing and Communication & 2012 IEEE 9th International Conference on Embedded Software and Systems (HPCC-ICES), 2012 IEEE 14th International Conference on.

Whitman, M., & Mattord, H. (2011). *Principles of information security*: Cengage Learning.

Williams, P. A., & Manheke, R. J. (2010). Small Business-A Cyber Resilience Vulnerability. Paper presented at the International Cyber Resilience Conference: Perth

#### Author Biographies



I graduated in B.Sc.Eng.(Hons) Computer Engineering from the Faculty of Engineering, University of Peradeniya, Sri Lanka, and I did my M.Sc (Computer Science) at the School of Computing, Flinders University, Australia. I am teaching at the University of Vocational Technology as a senior lecturer in the computing related module. Information Security is my interesting research area due to the significant impact to the sensitive information.

## IoT based Health Monitoring and Activity Detection for Elderly Care

Nethshan Narasinghe<sup>1#</sup>, RPS Kathriarachchi<sup>2</sup>, and M.W.P Maduranga<sup>3</sup>

<sup>1</sup> Department of Physics, University of Colombo, Sri Lanka

<sup>2</sup> Department of Information Technology, General Sir John Kotelawala Defence University, Sri Lanka

<sup>3</sup> Department of Computer Engineering, General Sir John Kotelawala Defence University, Sri Lanka

#nethshan@gmail.com

**Abstract:** It is very important to monitor the health condition and activity of the elderly people especially when they are living alone or due to reduced connection with their children and relatives. To automate the elderly activity monitoring, we developed an IoT-based (Internet of Things) health monitoring system with integrating various technologies of wearable and non-wearable devices that are connected to the wireless communication network. Heart rate sensor is wearable and fixed PIR sensors used for find the location. All sensors will communicate and send data to a cloud storage through a home Wi-Fi network. In this system, doctors or guardians can be monitoring elderly heart rate and able to track their real-time location through the data given by the sensors when they are living alone at home. Also, these data will be recorded in a remote IoT cloud. Thus these data can be used for data-driven predictions. Mobile app use for monitor the real-time health condition as well as actual location of the patient in the home. Also this app configured to push the notification when abnormal conditions are detected.

**Key Words:** Assisted Living, Internet of Things, Smart Systems for Elderly Care, Sensors

### Introduction

The Internet of Things (IoT) is the interconnecting of physical devices, sensors, vehicles, buildings, and other items embedded with electronics, software, sensors, actuators, and network connectivity which enable these objects to collect,

exchange data, and controlling. As people begin to grow older, they begin to lose the ability to do the same things that they were able to when they were younger. But, many elderly individuals prefer to live in their homes and refuse to move into an elderly care home. Each year millions of people experience abnormal heart rhythms (arrhythmias). Normal resting heart rate is 60 to 100 beats per minute (bpm). Abnormal heart rhythms can be described as a heart beating too fast (above 100 bpm) or slow (below 60 bpm). When electrical impulses in the heart become too fast, too slow, or irregular they cause the heart to beat irregularly [1][2] [3]. With effective monitoring and alarm systems, the adverse effects of unpredictable events such as heart attacks, sudden illnesses, falls, and so on can be ameliorated to some extent when they are staying alone. In this project, design state-of-the-art wearable technologies that can be used for elderly care. Elders need special attention to their health condition. What is the actual real-time health condition is the major problem facing by the relatives. In this project, we design a real-time health monitoring and behavior tracking system for elderly. The project is to design the only one lightweight wearable heart rate sensor and few PIR location identification sensors. It designed for targeting elderly people who are living alone. This wearable sensor is very easy to wear and there are machine learning and prediction method is used when data are missed. However, the total system can apply any of any age of people that need more care

of the health condition. Any authorized person can monitor real-time and analyze the historical health records through the internet. This system may allow the elderly to stay in their comfortable home environments and enjoy their normal lives safely. Others can also keep track of the overall health condition of the elderly in real-time and provide support from a distant place.

### **Related Works**

H Basanta<sup>1</sup> et al. developed a system support the real-time activity and monitor the healthcare system for the elderly citizens. In this method the information collected by various wearable sensors in real-time and stored in the central database. IoT H2U healthcare is a heterogeneous computing system of Apps and wearable devices that connect patients and healthcare service providers remotely by using the internet [4].

S. N. Malokar and S. D. Mali have developed a system that is supposed to be monitored continuously for Heart Rate, oxygen saturation level, and temperature as well. Analyzing different methods and techniques used for the health care monitoring system where doctors can continuously monitor the patient's condition on his smartphone and also the patient history will be stored on the webserver and doctors can access the information whenever needed from anywhere [5].

S. S. Kale and D. S. Bhagwat have developed a system that presents the architecture of IoT and architecture of Remote health monitoring using IoT. This system presents the problems and challenges that could come. Raspberry Pi kit, Wi-Fi modules, temperature, blood pressure, pulse oximeter, heartbeat rate sensors are used for this IoT based health care system [6].

All of the above systems are used many number of sensors are connected to the human body and it is a very un-convenient

method. The patient must wear the all sensors all over the day and those are not lightweight things. Also, few works used Raspberry Pi computer or other high-performance PCs to collect the data and push to the cloud [7][8][9]. Perhaps it may not an cost-effective method and also there is a lack of techniques for predicting patient condition whenever missed the sensor data involved.

### **System Overview**

The systems often consisted of four main parts which are wearable sensor, PIR sensors, cloud data storage, and mobile app. All units work together with an intelligent control system that allowed major advances and efficiency in health monitoring and controlling.

As shown in the above figure 1, heart rate sensors in the wearable unit are connected to the ESP8266 chip and data transmitted to the server by using TCP/IP protocol. All other non-wearable PIR sensors are mounted in different places in the home and those sensors monitor the activity of the person. All sensors are directly sending data to the cloud. All historical data and real-time health conditions can monitor by login to the system or can use the mobile app. Also Pop-up alert shows when the abnormal condition is detected. OLED display shows all real-time heart rate data to the person who is wearing the device. Blynk smart mobile app uses to monitor the real-time health condition as well as an actual location in the home. Also, this app configured to push the notification when abnormal conditions are detected..

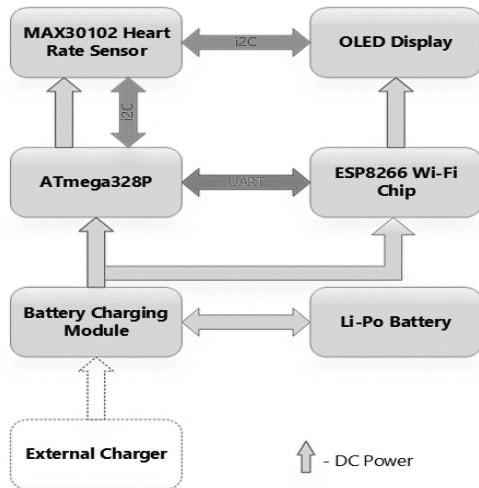

Figure 1: The system overview

### Design and Implementation

The design and the implementation of the assisted living system is detailed in this section. Figure 2, 3 and 4 show the wrist band heart rate monitor unit. Mainly it consisted of the MAX30102, OLED display, ATmega 328P chip and ESP8266 Wi-Fi module. The main device is wearable heart rate monitor is consist of MAX30102 chip. As shown in figure 5, it connect to the AtMega328 chip using I2C interface and OLED display used to show the heart rate. The AtMega328 chip send all data to the ESP8266 Wi-Fi module through UART port. Wi-Fi module send the heart rate data to the cloud and data store in the Google spreadsheet. First design the prototype unit by connect the all modules by using jumper. A 9900mAh Li-Ion batteries used for the first prototype. In final design, 500 mAh Li-Po battery was used as it is able to use the device for 24 hrs once fully charged.

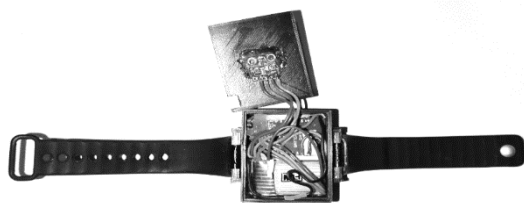

Figure 2: Wrist Band Design -Inside view



Figure 3: Wrist Band Design -back side view

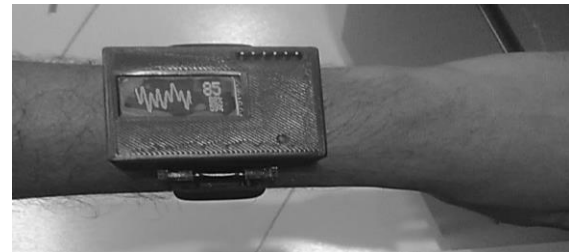

Figure 4: Wrist Band Design

To trace the presence of elder in specific area, we have installed five PIR sensors in bedroom, kitchen, bathroom dining area and master bed room as shown in figure 6. We design this sensor node to connect directly 230 V AC domestic power supply line with PIR sensor and ESP8266 Wifi module. Designed circuit was PCB printed as shown in figure 5. Which also includes a plastic enclose for protection.

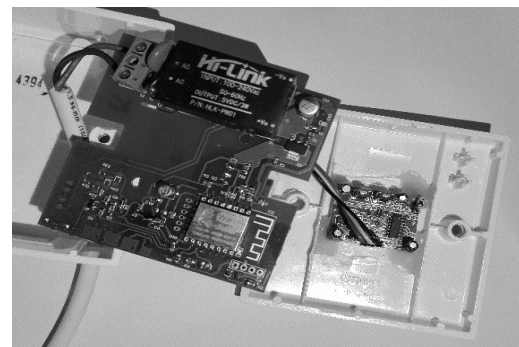

Figure 5: PIR Sensor Node

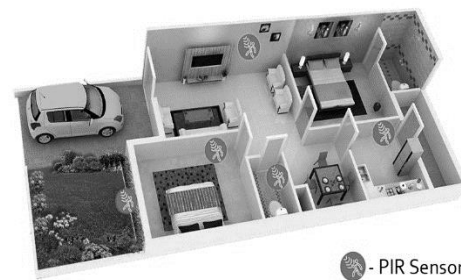

Figure 6: PIR Sensor arrangement inside the house

## Testing

This project was aimed to design as an elder's health monitoring system which consists of wearable heart rate monitoring devices and non-wearable PIR sensors. We installed five PIR sensors in a house and wear the wrist band by the elder. We get notifications to our mobile phone indicating the real-time location where the elder presently exists. Here we use freely available IoT cloud called 'Blynk' to get notifications to our mobile phone. Also, real-time heart rate value display in the same application. We collected heart rate data for five days of the same period of the day, each day and visualized it as shown in figure 7. We applied a moving average filter to remove outliers in the data pre-processing stage. Data visualization was very helpful for the study and understand about heart rate sensor behavior. We tested our system with the people in different ages and observed heart rate data and adjust the IR level of the sensor for work with all ages, body types, and body conditions. Blynk android app was used to receive the heart rate data. After that, data was collected for a few days to wear the device by the same person. All sensor data stored in the google drive.

Google spreadsheet saved in google drive used for store the heart rate data and PIR sensor data as shown in figure 7. A cloud-based architecture enables to collaborate with anyone, anytime, anywhere. Compatibility with external systems, including Microsoft Office and built on top of Google's infrastructure, Sheets gives the freedom to create, while helping to keep information secure.

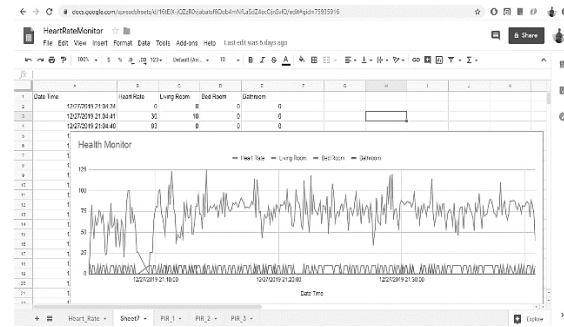

Figure 7: Screenshot of the saved data in the google sheet

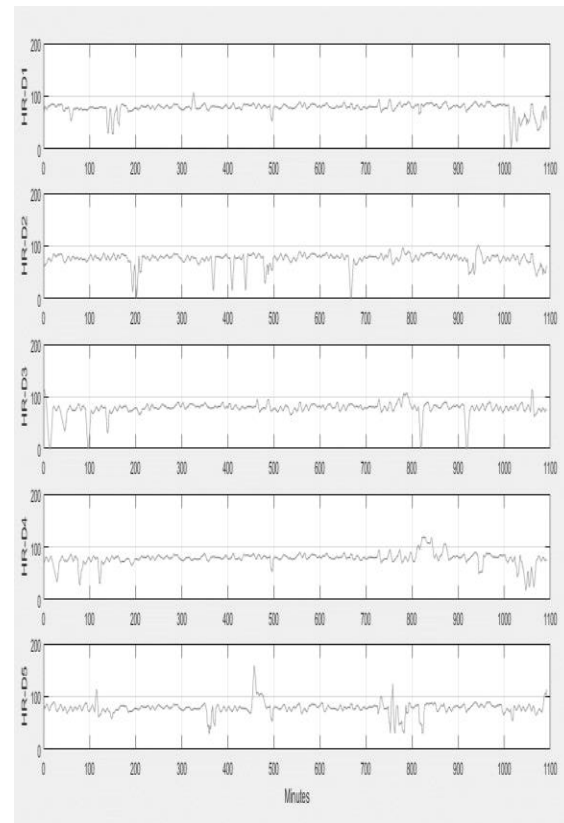

Figure 8: Heart Rate data for 24hrs

After completion of the heart rate sensing device and make the initial adjustments, data was collected of five different days (see figure 8) of the same period of the day by wearing the same person. Those data are plotted using MATLAB and graphs are shown in the above.

According to above plot, there was shows some positive overshoot and negative overshoot within very small time period such as between 1 minutes to 5 minutes. According to further studies and observations, those overshoots are

happened when shock the sensor or fast vibrations occurs.

4th plot is created by doing hard exercise between 810 to 845 minutes and data shows the how increase the heart rate. In that case heart rate increased between 100 to 125 BPM for 30 minutes.

According to above graphs, fine-tuned the alert message generating algorithm. Short overshoots are ignored and considered continuous heart rate increases or decreases than normal range more than 10 minutes were abnormal heart rate. According to above observation, program running in the ATmega328P chip was changed as like show in below flowchart of figure 9. Also referred the medical article of heart rate variation for prepare this algorithm [10].

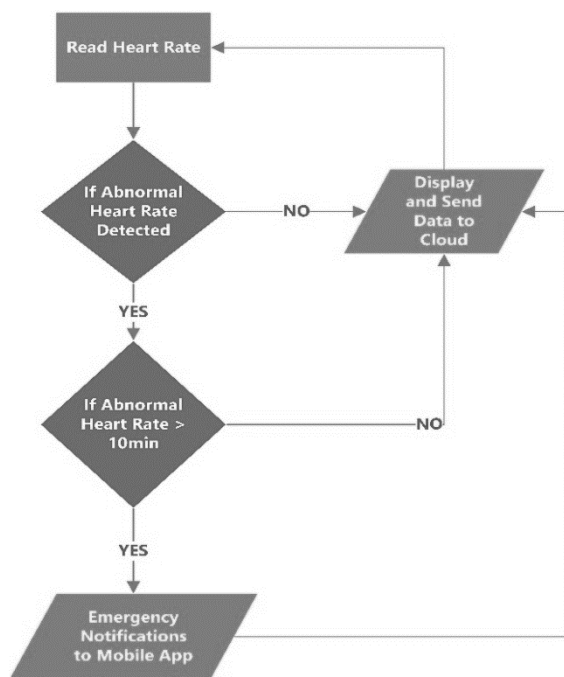

Figure 9: Flowchart of the emergency alert message generating algorithm

### Summary

We came up with a successful IoT based design for assisted living for elders. In this solution, doctors and relatives can be connected easily and monitor the elder's condition and activities using real-time sensors data and also analyzed the historical data saved in an IoT cloud for predictions.

This system helps the elder peoples to intervene from any worries hopefully preventing any difficulties when they stay alone at home as well as gardiance can receive the emergency alert messages when detect the abnormal conditions. Also, This health monitoring and predictive analytics system provides early treatment and early detection of signs of danger, avoiding hospitalization. Saved historical data on the IoT cloud, can access anywhere is a major advantage of the system. Sensors are connected through the IoT system is quite cost-effective and ensures a higher security level in terms of communication. As future works, machine learning can be integrated with this solution. As the system runs on electronics components and wireless networks. At any point, those components of data connection maybe fail. Also, the heart rate sensor is warble device and humans sometimes are maybe not ware it properly. That kind of situation, data could be lost. To overcome that issue machine learning prediction algorithms can be used to rebuild the missing data.

### References

- [1] O.A. Postolache, E. Sazonov, S. C. Mukhopadhyay, *Sensors in the Age of the Internet of Things: Technologies and applications*, Stevenage: Institution of Engineering & Technology, 2019.
- [2] V. Osetskyi, "IoT in Healthcare: Use Cases, Trends, Advantages, and Disadvantages DZone IoT," *dzone.com*, 14-Jun-2019. [Online]. [Accessed: Jan. 2, 2020].
- [3] Mayo Clinic, Heart arrhythmia, Mayo Clinic Hospital, Methodist Campus, 201 W. Center St. Rochester, MN U.S, Nov. 19, 2019. Accessed on: Jan. 2, 2020. [Online].
- [4] H. Basanta, Y. Huang and T Lee, "Intuitive IoT-based H2U healthcare system for elderly people," in *Proceedings of 2016 IEEE 13th International Conference on Networking, Sensing, and Control*, Mexico City, Mexico, April 28-30, 2016

[5] S. N. Malokar, S. D. Mali "An IOT Based Health Care Monitoring System-A Review," in *International Journal of Innovative Research in Computer and Communication Engineering*, Vol. 5, Issue 6, June 2017, pp. 11583-11589. Accessed on: Jan. 23, 2020. [Online].

[6] S. S. Kale, D. S. Bhagwat "Highly Secured IoT Based Health Care System for Elderly People using Body Sensor Network," in *International Journal of Innovative Research in Computer and Communication Engineering*, Vol. 5, Issue 10, June 2016, pp. 17796-17801.

[7] L. Mainetti, L. Patrono, A. Secco and I. Sergi, "An IoT-aware AAL system for elderly people," 2016 International Multidisciplinary Conference on Computer and Energy Science (SpliTech), Split, 2016, pp. 1-6, doi: 10.1109/SpliTech.2016.7555929.

[8] Chayapathy, G. S. Anitha and B. Sharath, "IoT based home automation by using personal assistant," 2017 International Conference On Smart Technologies For Smart Nation (SmartTechCon), Bangalore, 2017, pp. 385-389, doi: 10.1109/SmartTechCon.2017.8358401.

[9] R. Nunes Oliveira, V. Roth, A. Felippeto Henzen, J. M. Simao, P. Nohama and E. C. Gomes Wille, "Notification Oriented Paradigm Applied to Ambient Assisted Living Tool," in *IEEE Latin America Transactions*, vol. 16, no. 2, pp. 647-653, Feb. 2018, doi: 10.1109/TLA.2018.8327425.

[10] Murray Longmore, Ian Wilkinson, Andrew Baldwin, and Elizabeth Wallin, *Oxford Handbook of Clinical Medicine*, 9th ed. Oxford University Press, 2014.

## Author Biographies



N.D.N.M. Narasinghe obtained his BSc (Hons) in Electronics and Communication from University of Wolverhampton UK and his master degree in Applied Electronics from the University of Colombo. He also has IET membership and more than 10 years working experience as an electronics design engineer in IoT and Military & Aerospace field.



RPS Kathriarachchi obtained his BSc (Hons) in computer networks from University of Wolverhampton UK and his master's degree in MIT in the same university. He also a CISCO certified network associate and having more than 15 years of IT and IS systems. His current research interests include Internet of Things, Machine Learning, SWARM technologies. He has produced over ten peer-reviewed publications under his name.



M.W.P Maduranga obtained his BSc Eng degree in Electronic Engineering from the Asian Institute of Technology, Thailand and his master degree in Electrical and Electronic Engineering from the University of Peradeniya. He also a chartered Electrical Engineer registered under Engineering Council-UK. His current research interests include Internet of Things, Machine Learning in IoT and Wireless Communication. He has produced over ten peer-reviewed publications under his name.



## Analyzing the Influence of Various Factors for Vegetable Price using Data Mining

I.M.G.L. Illankoon, B.T.G.S. Kumara

*Department of Computing and Information Systems, Faculty of Applied Sciences, Sabaragamuwa University of Sri Lanka, Sri Lanka*

gayanilakshi101@gmail.com

**Abstract:** The price fluctuation of vegetables is one of the economic problems faced by every country, including Sri Lanka. Many factors such as environmental conditions as well as supply, demand, social, cultural, and political situations of the country cause the price of vegetables to fluctuate. In this study, the Waikato Environment for Knowledge Analysis (WEKA) tool and association based Apriori algorithms used to identify the most influential factors that affect price fluctuation. Results show that the low supply from cultivation areas is caused by an increased vegetable price and favourable supply from cultivation areas is caused by decrease vegetable price. Prices of vegetable varieties demonstrated mixed movements because of supply variability from respective areas. The findings of this study can be used by farmers to make their production plans, customers to plan their budget, and sellers to make their marketing plans.

**Key Words:** Data mining, Association rule, Apriori algorithm, Vegetable price patterns

### Introduction

Sri Lanka has over 2500 years of rich agricultural history and agriculture is one of the most important industries of the Sri Lankan economy. In Sri Lanka, rice production ranks first in terms of agriculture. In addition to rice, vegetable production also plays a major role in national economic and social stability. In Sri Lanka, more than forty different varieties of vegetables are grown in various agro-climatic areas and 602,000 metric tons of vegetables are produced

annually (Sri Lanka Export Development Board, 2013). Upcountry vegetables and low country vegetables are the two types of vegetables grown in Sri Lanka. Some of them are cultivated as commercial crops. Low-land and dry-wet areas are most suitable for a variety of tropical vegetables such as green chili, ladies' fingers, eggplant, cucumber, pumpkin, red onion, bitter gourd, etc. In the upcountry, the cool and stable weather conditions are perfect for temperate crops such as carrot, cabbage, leek, salad leaves, cauliflower, beet, tomato, bell pepper, and salad cucumber. But, low country varieties are also grown in these areas. These vegetables remain an important source of income. Most of the vegetables grown in Sri Lanka are consumed locally and less than one percent is exported (Esham and Usami, 2006).

Vegetable prices in Sri Lanka are highly volatile. There are many reasons for the vegetable price fluctuation. Environmental conditions such as rainfall patterns, temperature, wind, soil, and humidity impact on vegetable price fluctuation. In addition to the above reasons, some of the other factors such as the social, cultural, economic, political situation of the country, supply, and demand can be affected by vegetable price variation.

Many researchers conduct research works based on analyze factors' impact on agricultural production and analyze price behaviour using various methods. Most of the researches has been conducted using

surveys, case studies, and statistical approaches. But today, using techniques from data science to increase efficiency, especially in agriculture is very important. Data mining may help to convert raw data into meaningful information for improving agricultural uses because data mining represents a set of specific methods and algorithms aimed at extracting patterns from raw data. Data mining techniques can be divided into predictive and descriptive. Descriptive data mining is used to analyze data and provide information about past and recent events. The predictive data mining provides answers to possible questions using historical data. Classification, regression, time series, and prediction can be considered as the predictive type and clustering, association rules, summarizing and sequence discovery can take as the descriptive methods (Kaur, Gulati and Kundra, 2014). Among them, association rules mining can be used to identify the association between factors such as weather conditions, supply, demand, seasonality affecting vegetable price, and price behaviours. (Rashid, Nohuddin and Zainol, 2017).

In this research, association rule-based Apriori algorithms are used to identify the patterns and association between most influential factors that affect price fluctuation and price indicates. The findings of this research will be useful for farmers to prepare and decide on production plans and improve profit, sellers to plan about the market for these vegetables, customers to plan their budget, and the government to create laws and regulations regarding cultivation and export-import concerns.

The rest of this paper is organized as follows. Section II describes the related work. Section III provides a brief overview of the research methodology and experimental design. Section IV describes the results and finally, we conclude the paper in Section V.

## Related Works

Many researchers around the world have conducted many studies from different perspectives to find out the main reasons for the fluctuations in prices for different crops, price behaviours, and the factors affecting agricultural production. Research work (Armstrong and Gandhi, 2016) presented some interest rules related to the influence of distributed seasonal rainfall on rice production in Rajasthan, India. Apriori algorithm was applied on data sets and results showed that normal or good rainfall is required to get a good rice harvest. Another research (Tanna and Ghodasara, 2015) work has demonstrated how pattern mining is done using association rules for agricultural datasets. Research work (Geetha, M.C.S, 2015) discusses the role of data mining techniques in the agriculture field and their related work by implementing association rule mining for different soil types in the context of the agriculture domain. Another study by (Wankhede, Armstrong, and Gandhi, 2018) investigated the spatial and temporal variation in rainfall and jowar crop production in the Maharashtra state of India. Authors used association rule mining techniques to observe the relationship between rainfall patterns and crop productivity across districts and years.

## Research Methodology

Figure 1 shows the proposed approach and it contains several steps including data collecting and creation of data sets, computerized data, and analysis, processes the data, and feature extraction.

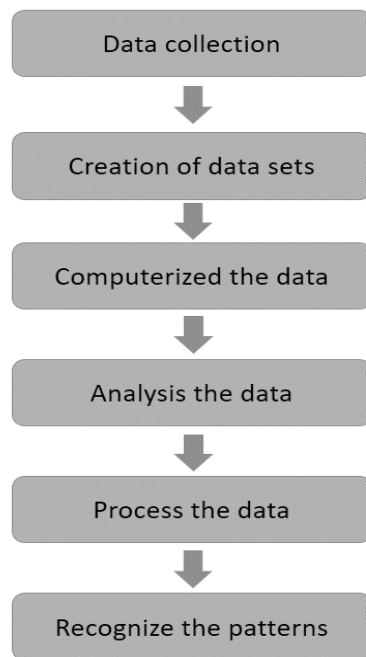

Figure 22: Research methodology

#### A. Collecting and Creation of the Data sets

We conducted our research based on wholesale vegetable prices in Sri Lanka and the most influential factors for the change of vegetable prices. Daily wholesale prices and average weekly wholesale vegetable prices of three vegetables namely beans, carrot, and brinjal and, the reason for the influence of vegetable price in Pettah market, Sri Lanka from June 2017 to December 2019 which were published by the Department of Census and Statistics in Sri Lanka, Central Bank of Sri Lanka and Hector Kobbakaduwa Agrarian Research and Training Institute have been utilized for this research.

To get an idea about price variation patterns, we created graphs using average weekly wholesale prices. To discover frequent associations, we used daily wholesale vegetable prices and details about influential factors.

The dataset contains four attributes and they are total wholesale vegetable price, month, influential factor, and fluctuation type.

- 1) Total wholesale vegetable price: The total wholesale vegetable price of beans,

carrot, and eggplant were classified as very low (Rs 0 to Rs 199), low (Rs 200 to Rs 399), high (Rs 400 to Rs 699), and very high (Rs 700 to Rs 1000).

- 2) Month: The attribute named 'Month' specifies the name of the month.
- 3) Influential factor: The attribute named 'Influential factor' is categorized into weather, low supply, high supply, festival, seasonality, mix supply, and other.
- 4) Fluctuation type: Fluctuation type is categorized into increase, decrease, and mix movements.

#### B. Computerized data and analysis

Before the analysis, the collected data was prepared and computerized. The data was converted to .csv format for further applying preprocessing techniques using WEKA (Waikato Environment for Knowledge Analysis) filters. Here the dataset was checked for removing missing values and outliers.

#### C. Process the data and feature extraction

The technology used for extract patterns and analysis is WEKA (Waikato Environment for Knowledge Analysis) tool. WEKA contains a group of algorithms and visualization tools for data mining and predictive modeling, and also it contains graphical user interfaces (GUI) for access to those functions. WEKA supports many standard data mining tasks like data pre-processing, clustering, classification, regression, visualization, and feature selection (Frank et al., 2017). In this research, the Apriori algorithm was used to extract association rules from the dataset. Apriori algorithm is the best and most commonly used algorithm for mining frequent patterns for association rules (Hashim, Hamoud, and Awadh, 2018).

#### D. Association rule mining

Association rule mining is a widely used approach in data mining. Association rules are capable of finding frequent patterns, associations, and important relationships in large databases and it provides an effective scientific base for decision making. Association rule mining uses the measuring criteria support and confidence to determine the most important relationships. Support means how many times the items appear in the dataset and the confidence means the number of events if-then observations are found true.

There are various algorithms for finding association rules such as Apriori Tid, Apriori, Eclat, AIS, SETM, Apriori hybrid, and FP-growth (Mishra, Pani, and Ratha, 2019). Among them, the Apriori algorithm is the best and most commonly used algorithm for mining frequent patterns for association rules.

#### Results

##### A. Results of the Data Creation and graphical analysis

According to graphs that are created using the average weekly wholesale prices, the following figures show the price behaviours for beans, carrot, and eggplant in the year 2017, 2018, 2019, and 2020.

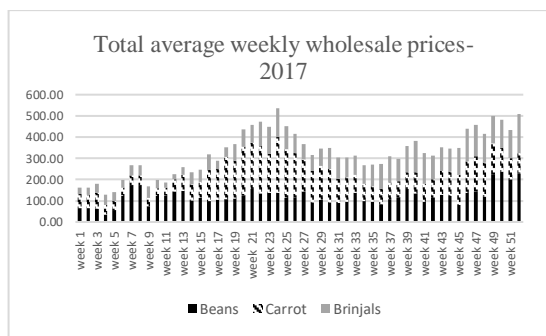

Figure 23: Price behaviours for 2017

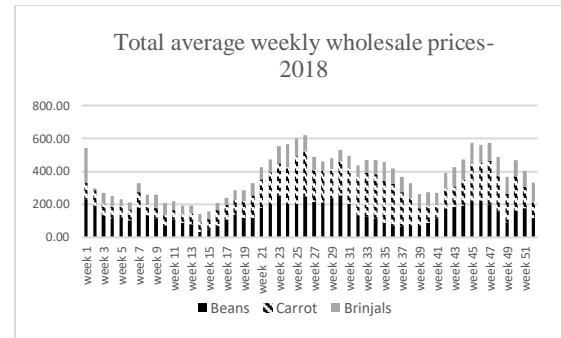

Figure 24: Price behaviours for 2018

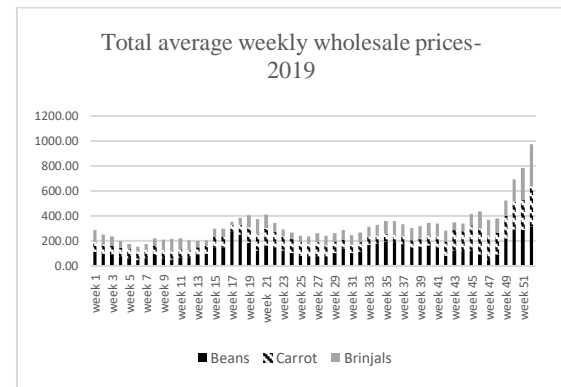

Figure 4: Price behaviours for 2019

According to the graphical analysis, from November to February and from May to July selected vegetables indicate high prices. Furthermore, prices dropped from August to October and from March to April.

And the collected data about vegetable price and influence factors consist of detailed descriptions that data cannot analyze using data mining algorithms. Under this step, data were summarized using abbreviations. Table 1 shows those abbreviations.

Table 2: Abbreviation

Attribute	Description	Abbreviation
Total price	Very low (Rs 0 to Rs 199)	VL
	Low (Rs 200 to Rs 399)	L
	High (Rs 400 to Rs 699)	H
	Very high (Rs 700 to Rs 1000)	VH
Influential factors	Weather condition	w
	High supply	hs
	Low supply	ls
	Festivals	f
	Seasonality	se
	Supply variability	s
	Other reasons	otr
Fluctuation type	Increase price	i
	Decrease price	d
	Mixed movements	m

The following figure shows some parts of the created dataset before the analysis.

No.	1: price Nominal	2: month Nominal	3: factor Nominal	4: fluctuation Nominal
1	H	may	otr	m
2	H	may	otr	i
3	H	may	otr	i
4	H	may	otr	i
5	H	jun	w	i
6	H	jun	w	i
7	H	jun	w	i
8	H	jun	w	i
9	H	jun	w	i
10	H	jun	w	i
11	H	jun	w	i
12	H	jun	w	i
13	H	jun	s	m
14	H	jun	s	m
15	H	jun	s	m

Figure 5: Created dataset

### B. Results of the data analyze

The created dataset has analyzed using WEKA. Before analyzing, WEKA pre-processing used to remove missing values from the data set. The following figures visualized all the data after analyzing.

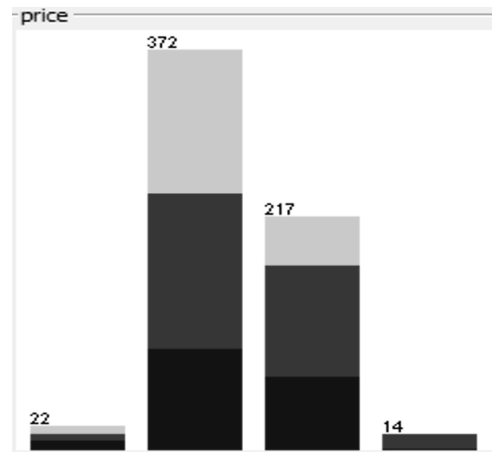

Figure 6: Data visualizing (price)

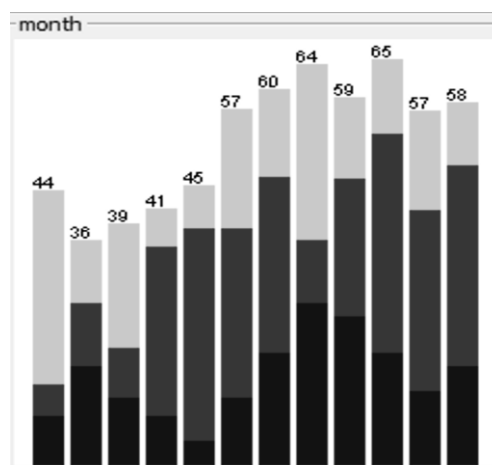

Figure 7: Data visualizing (month)

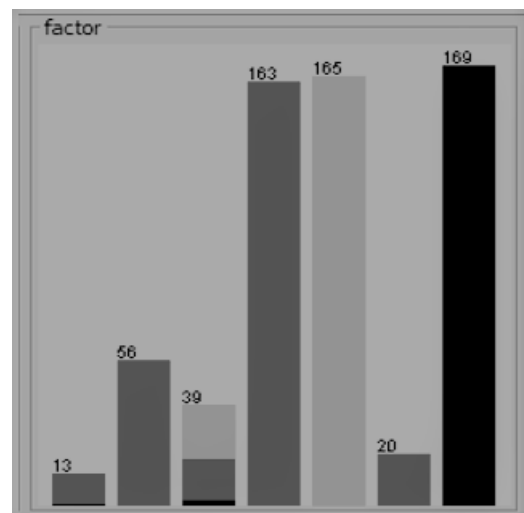

Figure 8: Data visualizing (factor)

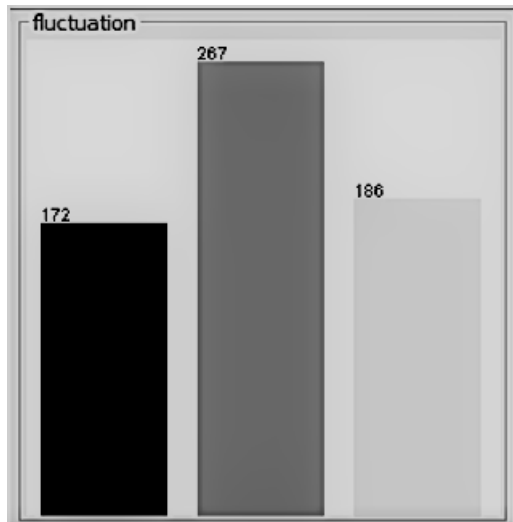

Figure 9: Data visualizing (fluctuation)

### C. Association Mining

The best rules were extracted from the dataset using the WEKA tool. Table 3 shows the best rules found in the Apriori algorithm. The results depend on the comparison of confidence, leverage, and convince. The measure of minimum support performed over Apriori was 0.1 (70 instances), and minimum confidence was 0.91.

Table 3: Association model for Apriori algorithm

Minimum support	Minimum metric <confidence>	Number of cycles performed
0.1 (62 instances)	0.9	18

After the Apriori algorithm is executed, we can obtain many results. According to Rule 1 and Rule 9, wholesale prices of vegetable varieties demonstrated mixed movements (m) because of supply variability (s) from respective areas. Rule 2 describes that prices of vegetable varieties decreased (d) due to favorable supply (hs) from respective areas. Rule 3 explains that the price of vegetable varieties increased (i) due to low supply (ls) from respective areas. According to Rule 4, prices of vegetable varieties decreased (d) due to favorable supply (hs) from respective areas, and the total price of carrot, beans, and eggplant can fluctuate between Rs.200 to

Rs.399 in each day. Rule 5 displays the price of vegetable varieties increased (i) due to low supply (ls) from respective areas and the total price of carrot, beans, and eggplant can fluctuate between Rs.200 to Rs.399 in each day. Total wholesale prices of carrot, beans, and eggplant can fluctuate between Rs.200 to Rs.399 and it demonstrated mixed movements (m) because of supply variability (s) from respective areas according to Rule 6 and Rule 8. Finally, Rule 7 and Rule 10 display that, wholesale prices of vegetable varieties demonstrated mixed movements (m) because of supply variability (s) from respective areas, and the total price of carrot, beans, and eggplant can fluctuate between Rs.400 to Rs.699 in these days.

Table 3: Best rules obtained after applying Association Rule

No.	Rule
1	factor=s 169 ==> fluctuation=m 169 <conf:(1)> lift:(3.65) lev:(0.2) [122] conv:(122.69)
2	factor=hs 165 ==> fluctuation=d 165 <conf:(1)> lift:(3.35) lev:(0.19) [115] conv:(115.82)
3	factor=ls 163 ==> fluctuation=i 163 <conf:(1)> lift:(2.34) lev:(0.15) [93] conv:(93.25)
4	price=L factor=hs 117 ==> fluctuation=d 117 <conf:(1)> lift:(3.35) lev:(0.13) [82] conv:(82.13)
5	price=L factor=ls 100 ==> fluctuation=i 100 <conf:(1)> lift:(2.34) lev:(0.09) [57] conv:(57.21)
6	price=L factor=s 93 ==> fluctuation=m 93 <conf:(1)> lift:(3.65) lev:(0.11) [67] conv:(67.51)
7	price=H factor=s 67 ==> fluctuation=m 67 <conf:(1)> lift:(3.65) lev:(0.08) [48] conv:(48.64)
8	price=L fluctuation=m 94 ==> factor=s 93 <conf:(0.99)> lift:(3.65) lev:(0.11) [67] conv:(34.27)
9	fluctuation=m 171 ==> factor=s 169 <conf:(0.99)> lift:(3.65) lev:(0.2) [122] conv:(41.56)
10	price=H fluctuation=m 68 ==> factor=s 67 <conf:(0.99)> lift:(3.64) lev:(0.08) [48] conv:(24.79)

## Discussion and Conclusion

In this paper, we aimed to find patterns related to the most influential factors that affect price fluctuation and price indicates. In this work, we do our research based on the average weekly and daily wholesale prices of three vegetables namely beans, carrot, and eggplant, and reason for influence vegetable price from 2017 to 2019. We have taken data that contains attributes such as total price, month, influential factor, and fluctuation type.

According to the graphical analysis of average weekly wholesale vegetable prices, it implies that the price of vegetables can fluctuate from a higher value to a lower value on any given day and that is not possible to provide an exact price for vegetables.

The results of applying the association rule-based Apriori algorithm through WEKA is showing that low supply from cultivation areas is caused by increase vegetable price and favourable supply from cultivation areas is caused by decrease vegetable price. Wholesale prices of vegetable varieties demonstrated mixed movements because of supply variability from respective areas.

In future work, we planned to evaluate our approach with classification methods. We also plan to implement the vegetable price prediction approach by considering the identified factors.

## Acknowledgment

We pay our sincere gratitude to the staff of the Department of Computing and Information Systems, Sabaragamuwa University of Sri Lanka.

## Author Biographies



I.M.G.L. Illankoon is a degree candidate for the Department of Computing and Information Systems, Sabaragamuwa University of Sri Lanka. She

applies her knowledge about Data Science for this research.



Banage T.G.S. Kumara received a Bachelor's degree in 2006 from Sabaragamuwa University of Sri Lanka. He received a master's degree in 2010 from the University of Peradeniya and a Ph.D. degree in 2015 from the University of Aizu, Japan. His research interests include semantic web, web data mining, web service discovery, and composition.

## References

- Armstrong, L. J. and Gandhi, N. (2016) 'Assessing impact of seasonal rainfall on rice crop yield of Rajasthan, India using Association Rule Mining', pp. 1021-1024.
- Esham, M. and Usami, K. (2006) 'Procurement behavior of the fruit and vegetable industry in Sri Lanka', *Journal of Agricultural Sciences*, 2(3), p. 36. doi: 10.4038/jas.v2i3.8135.
- Frank, E. et al. (2017) 'The WEKA Data Mining Software: An Update', 15(4), pp. 452-465. doi: 10.1080/14733285.2016.1271943.
- Geetha, M.C.S (2015) 'Implementation of Association Rule Mining for different soil types in Agriculture', *Ijarcce*, 4(4), pp. 520-522. doi: 10.17148/ijarcce.2015.44119.
- Hashim, A. S., Hamoud, A. K. and Awadh, W. A. (2018) 'Analyzing Students' Answers Using Association Rule Mining Based on Feature Selection', *Journal of Southwest Jiaotong University*, 53(5), pp. 1-16.
- Kaur, M., Gulati, H. and Kundra, H. (2014) 'Data Mining in Agriculture on Crop Price Prediction: Techniques and Applications', *International Journal of Computer Applications*, 99(12), pp. 1-3. doi: 10.5120/17422-8273.
- Mishra, A. K., Pani, S. K. and Ratha, B. K. (2019) 'Association Rule Mining with Apriori and FPGrowth Using WEKA', *International Journal of Advanced Technology in Engineering and Science*, (September 2015).
- Rashid, R. A. A., Nohuddin, P. N. E. and Zainol, Z. (2017) 'Association Rule Mining Using Time Series Data for Malaysia Climate Variability

Prediction', (October). doi: 10.1007/978-3-319-70010-6.

Sri Lanka Export Development Board (2013) 'Industry Capability Report Sri Lankan Fresh Fruit & Vegetable', (January), p. 10.

Tanna, P. and Ghodasara, Y. (2015) 'Using Apriori with WEKA for Frequent Pattern Mining', International Journal of Engineering Trends and Technology (IJETT), Volume 12(June 2014). doi: 10.14445/22315381/IJETT-V12P223.

Wankhede, S. S., Armstrong, L. J. and Gandhi, N. (2018) 'Characterising the influence of drought on Jowar crop production in India using association rule mining', Proceedings - 2017 IEEE Technological Innovations in ICT for Agriculture and Rural Development, TIAR 2017, 2018-January(TIAR), pp. 57-63. doi: 10.1109/TIAR.2017.8273686.



## UECS: University Eligibility Checking System for State Universities in Sri Lanka

ABTMAS Bandaranaike<sup>1</sup>, IWMHD Bandara<sup>2</sup>, DA Iddamalgoda<sup>3</sup>, BLA Kalhari<sup>4</sup> and WPJ Premarathne<sup>5</sup>

<sup>1,2</sup> *Department of Computer Engineering, Sri Lanka*

<sup>3,4,5</sup> *Department of Computer Science, Sri Lanka*

#achintha.sanith@gmail.com

**Abstract:** Most of the systems regarding the application submission are merged with the official web site of the education institute/university or organization. When selecting courses, the most eligible course should be mentioned as the first option in the application form. So, to make the right selection, the applicant should be more aware of the available degree programs suitable for his/her Z-Score. The requirement of the UECS system emerges as a solution to overcome the inconveniences caused during the selection of a suitable degree program when applying to the government universities in Sri Lanka. The current process of University Grant Commission (UGC) university application & the difficulties faced by the applicants are identified and the modules of the proposed system are discussed through the functional and non-functional requirements identified by analysing the existing system. The introduced application will help students to check their individual eligibility for degree programmes offered under state universities of Sri Lanka. The system is developed by using an open resource platforms such as PHP, Hyper Text Markup Language, Cascading Style Sheet. The system was able to guide the students to select most suitable degree programme and the universities which offer the degrees according to their eligibility criteria's.

**Keywords:** University eligibility, UGC, Z-score

### Introduction

The University Grant Commission (UGC) is the apex body of the University System in Sri Lanka. The functions of the UGC are planning & coordination of university education, allocation of funds to higher educational institutions & maintenance of academic standards. Today, there are 10,390 government schools. The curriculum offered is approved by the Ministry of Education. Literacy rates and educational attainment levels rose steadily after Sri Lanka became an independent nation in 1948 and today the youth literacy rate stands 97% (Anon., 2020). The government gives high priority to improving the national education system and access to education.

In addition to the Government schools, there are 33 non-fee-levying Assisted Private Schools and 33 fee-levying autonomous Private schools (Anon., n.d.). Sri Lanka has 15 universities, all of which are public institutions (Anon., 2020). Admission at an undergraduate level to these public universities are based solely on the results of the G.C.E (A/L) Examination and the Z-score, which considers the difficulty level of the subjects. Only 6% of the students who sit the examination are admitted to the universities (Anon., 2013/2014). Due to restricted facilities admissions have become competitive. Accordingly, the selection of students to universities for the academic years are based on the Z-Scores of the G.C.E. (A/L) Examination to be held in the previous years, will be made in accordance with the

decisions subject to the rules and regulations to be issued with the Handbook on "Admission to Undergraduate Courses of the Universities in Sri Lanka". The percentage of students to be admitted to universities from those sitting for the G.C.E. (A/L) Examination for each degree program on district merit from each district and all-island merit shall be the composite average percentage of students admitted to universities through their very first attempt (Anon., n.d.).

Since the course selection should be done while referring to the handbook, it is not easy to filter the most suitable degree for one's z-score, and most of the time applicants choose the degree according to their desire. According to the UGC annual report, the percentage selected under normal provision out of qualified & applied is 17.1% & 38.8% respectively (Anon., 2011). The rest of them are unqualified may be due to the incorrect submission of the application or if they didn't possess the required results. Therefore, there is a huge need of providing support to choose the most suitable degree for each candidate to help them to get into universities in their first attempt. The existing system only provides eligibility checking while there is no filtering of degrees in the priority order when selecting for the application. Through the UGC handbook, it guides the user with instructions to fill up the application. Since the selection process is competitive, choosing the most suitable degree program for each z-score is most essential. The proposed University Eligibility Checking System (UECS) is a supportive system that can be used to simplify the overall procedure of the UGC Handbook.

Modules of the proposed UECS consists of the user Authentication Module, User Verification Module & Report Generation Module. Mainly we aim to create a dedicated web application for the system. The web application will be mainly based on the languages HTML, PHP, and CSS. We will be

coding all the web pages in the web application using these three languages. The database connection will be done by using SQLite & there will be a database created for three different categories. The graphics will be created using Photoshop. And then they will be brought into the web pages to combine with the three languages. The basic part of the web application will be coded using HTML and CSS languages. But the database connection part will be done by using the PHP language.

The rest of the paper is structured as follows: A study on existing systems is given in section 2. Section 3 discusses the Methodology and section 4 discuss How the system works and finally, section 5 will provide some concluding remarks.

### **A Study on Existing Systems**

Most of the systems developed in Sri Lanka are developed based on online application submission in both government and private universities.

UGC has developed their admission process to an online platform in recent past years. But still they ask hard copy of admissions filled by the students. They give instructions students to send the hard copy by post. Though we say it is online process we have to do a considerable part of applying universities manually. UGC is providing a university handbook after they published AL results. Student have to buy them from the authorized book shops and go through it and select the universities that they can apply and their preference. It is a something big task as the hand book has large number of chapters. After going through the handbook we have to log the UGC site and fill the application according to their instructions. They have provide around 100 rows to select universities and courses according to students preference and eligibility. Students have to select them manually and fill them with their Unicode.

NSBM Green University is an identified national institute that allows students to engage with their higher education. The entrance to the online student registration and recruitment system is provided on the official website with a demonstration of an icon. National Institute of Business Management is also consisting of an online application form but still, it didn't have an eligibility checking option (Anon., n.d.). The online applying facility in NIBM is limited for several course modules. Since NIBM has not indicated any direct link to apply online, system users have to search for the system (Anon., n.d.).

The system implemented by NSBM and NIBM is having application forms to be filled in a very abstract way (Anon., 2009) Normally, details regarding the courses are provided in the web site as a separate web page rather than providing carrier guidance. The Providence of carrier guidance is an added advantage for the system's usability. The carrier guidance module is provided on the website of the ESOFTH higher education institute. ESOFTH doesn't comprise online application submission but it comprises a web-based system to place inquiries for a particular course program (Anon., n.d.).

The Open University of Sri Lanka is another national body that comprises of online application submission system initiated through the official website of the university. The secureness of the entire application submission system is at a high standard. An account must be created to access the application to be filled. And then the system themselves allows a secure server to pay the application fee online. This increases the usability, productiveness of the entire system of application submission (Anon., 2014).

CINEC is a leading private university in Sri Lanka. It doesn't have online admission criteria and it only consists of an inquiry

system and the application for admission is available on their website (Anon., n.d.).

UNIVOTEC (University of Vocational Technology) is a government University which provides technical and vocational education for students. They provide their admission through an online process that can follow easily for students (UNIVOTEC, n.d.).

The KDU is the only university in the island which offers higher education opportunities for both military and civilian personnel in a disciplined environment. Kotelawala Defense University is the only university which can check the eligibility as a part of online application submission. But still, it isn't able to provide a prioritized list of degree programs according to user provide details (Anon., n.d.).

## Methodology

### A. The architecture of the system

Figure 1, The System Architecture illustrates the generic flow of handling the main components of the proposed system of UECS. Overall System Architecture segmented the

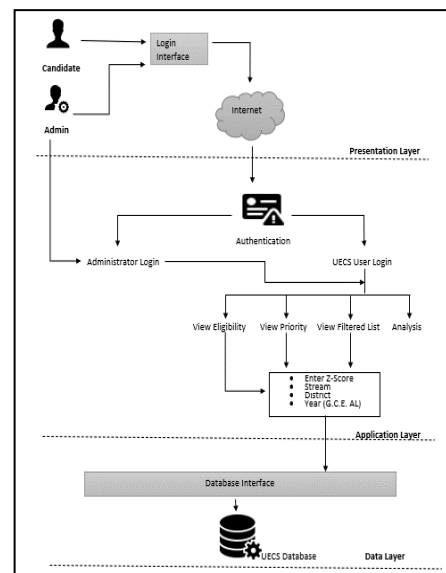

Figure 1: Overall System Architecture

whole system into three layers consecutively and all the three layers are interconnected.

The application layer, Data layer, Presentation layer are the three segments.

The application layer is focusing on the logic of how the users interact with the application while the Data layer is responsible for evaluating the method of how the data is stored in the database server. The presentation layer evaluates the details about how the user interacts with the interfaces of the proposed UECS.

Each general user of the system needs to be logged on to the system before using the system. Each user will be provided with a unique username and password to access the system by the administrator. When they are entered in the login interface those values will be verified using the data in the database and redirect the user to the system to achieve the results as user required. When the user is logged into the system he/she can request for their individual need by providing necessary information by filling the form. After that, the updates are stored in the database and the output will be received as required. The degree programs, the user is eligible for are displayed according to the most priority.

The UECS will have one centralized database in the server. MySQL database will be used for this purpose. Conceptual Data Design of the proposed system of UECS gives a detailed view of the database structure. Designing the database for particular applications is categorized and is denoted with supertype and subtype relations. Each table depicts the relevant attributes to the particular entity which is identified at the conceptual database design of the system.

## B. Interface Design

To enter the given options of UECS, users need to first register in the system. When submitting the username and password database checks the validity of the entered username & password. Then it checks the user levels & provides the sign-in window. After a successful login, the user gets the home window. Figure 2 depicts the main

home page when a user gets interacted with before logging in to the available options.

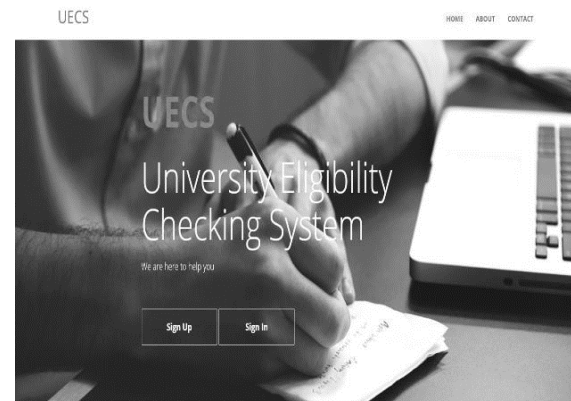

Figure 2: Home page UECS

It consists of a scroll up window while the menu tab displays above in return link back to the sub-windows which contains home, about & contact inside the home window. Once the user is login to the system, he is free to use any of the options provided by the website.



Figure 3: Home page after successful login

Figure 3 shows the main interface of the system after a successful login. Figure 4 shows the available options for the user to be select according to his/her wish.

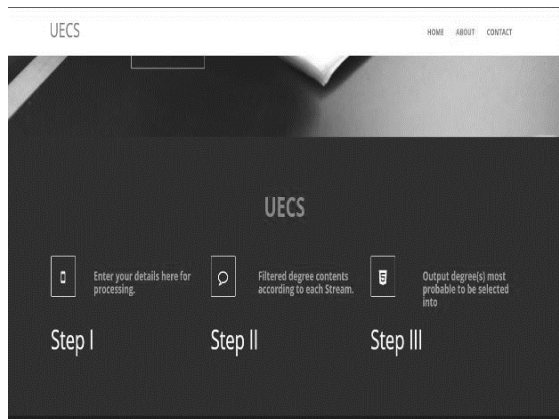

Figure 4: Options to be selected

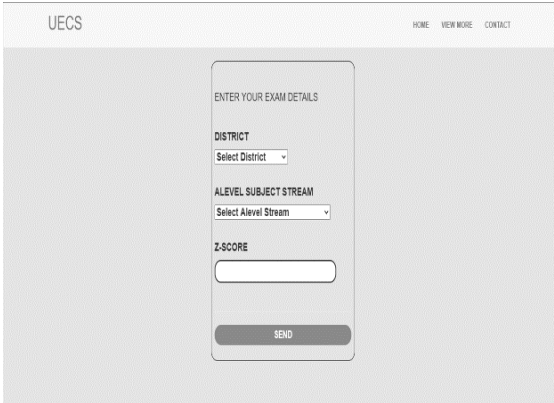

Figure 5: Form

Once he/she submits the form (Figure 5) after completing, it will be stored in the database and the prioritized degrees will be sorted out from most probable to least probable order, that he/she is eligible with. UECS will contain the main 3 sections namely “Output degrees most probable to be selected into”, “filtered degree contents” & “Background analysis”. Each section will have specific functions under them. The background analysis part will make the user get a clear idea about how the selections are made during the previous years and how the priorities are given in each university.

All the interfaces & forms needed which are described above are designed using HTML to produce user-friendly interfaces.

The protocols used in requirement gathering and the justification of using those protocols are analyzed so that the data gathered can be used appropriately in designing and developing the system. The modules of the

proposed system are identified through the functional and non-functional requirements identified in analyzing. The proposed UECS aim is to deliver a system that is eligible in maximum user-friendliness through efficiency, accuracy, reliability achieving through the functionality of the system.

Information regarding the existing procedure is very much essential for the achievement of the goal of the proposed project. The following are the fact-finding techniques used.

- Interviews
- Questionnaires
- Documentary reviews

Information regarding the current procedure of university application submission was gathered by interviewing the relevant parties. An initial interview is carried out with the Deputy registrar of the examination department of UGC to understanding the process of the existing overall university applying process. While a Questionnaire is made to find the opinions of the applicants. Method of categorizing the applications and the selections made in previous years are emphasized through the documentary review.

Candidates who have the minimum qualification can apply for the university but the selecting of degrees in the most appropriate order is important because it may conclude that he/she is being selected for a government university or not. The applicant should know how the selections are made and this knowledge can be gain by referring to the UGC handbook as all the instructions are noted. Selecting a prioritize list of most eligible degrees while referring to the UGC handbook was somewhat difficult and time-consuming. If the applicant didn't have any idea about the previous year's selections, then he/she may not able to fill the application as required by the UGC

(Anon., 2019). Due to the incorrect submission of applications, most of the students are unqualified for the university entrance. Once the degree is mentioned it is not allowed to change the order of the list of degree programs the applicant is willing to apply and now this is cleared up to some extent but if a certain candidate wants to make a correction on their application form they have to inquire it and wait for an acceptance email and it is time-consuming.

The outcome is analyzed as quantitative measurement and get the feedback about the prevailing system which we need to pay our attention when designing the UECS.

### How the System Works

Figure 6 shows how the system interacts with each module. First, the user must create a login if he wants to use the platform. Then he can view three options as “Output degrees most probable to be selected into”, “filtered degree contents” & “Background analysis”. Once the user clicks on either the first or second option the system will guide them to a user form where the user needs to fill in all the details and submit.

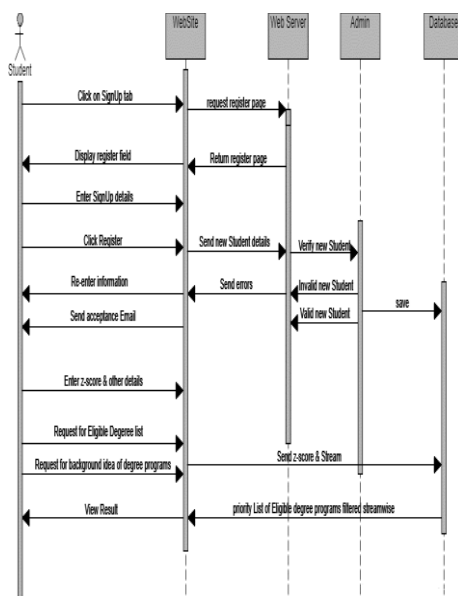

Figure 6: Order of interactions of the UECS operations

The submitted form is get stored into the database and filtered according to the user

requirement which was requested as earlier when selecting the options. The functionalities of the system can be viewed below.

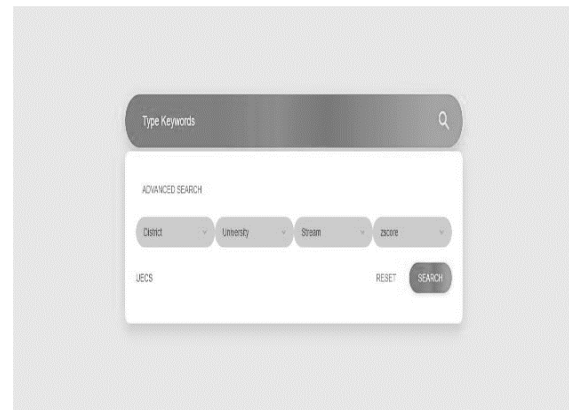

Figure 7: Advanced search

After entering the form details it will direct to the above form shown in figure 7 and it will direct the user to make the selection process more user friendly. He/she can differentiate more the list of eligible degrees by filtering them according to university, district, and stream. That is if one person is like to apply for a particular university from a particular district through a particular stream then the degrees he/she is eligible can be viewed in this way. In this option, the filtered list of eligible degrees is again subjected to another filtering process to view the best-sorted list from the system to user’s satisfaction which is shown below in figure 8.

Sortable Table of Search Course of studies			
Degree	Z-Score Required	University	
Business Science	1.5675	University of Moratuwa	Colombo
Computer Science	1.5665	University of Colombo School of Computing	Colombo
Facilities Management	1.5556	University of Moratuwa	Colombo
Computation & Management	1.5531	University of Peradeniya	Colombo
Computation & Management	1.5531	University of Peradeniya	Colombo
Computer Science	1.5244	University of Kelaniya	Colombo
Computer Science	1.5208	University of Ruhuna	Colombo
Industrial Statistics &	1.5004	University of Colombo	Colombo

Figure 8: Sorted form of list of degrees

Rather than this he/she can directly have the eligible list of prioritizing the list of degrees as shown in figure 9 below.

Processing the advanced level results of the ever-increasing youth requires massive

amounts of manpower, resources and it consumes time, time that industries in the economy provide so little of. Taking advantage of this the private universities can recruit much of the candidates by registering students long before the UGC provides registration dates (Silva, n.d.). Rejection of University applications is a common problem seen today which can be caused by several reasons, all contributing to the candidates' frustration and causing them to overlook the fact that he or she could have been selected and make them select a private university (R.P.Gunawardane, 2017). If the students can know beforehand if they have the chance of being selected into a government university, it would help greatly in making future decisions. Our website does just that by taking user Streams and Z-scores and providing them with their eligible degree programs and showing them all the options, they have to start their careers.

Further enhancement proposed on the system will expand the planned scope of the development. The implemented system of UECS is planned to further develop by expanding the system to all the streams that students face AL. and supposed to develop a mobile application.

## References

Anon., 2009. Government Information Centre. [Online] Available at:

<http://gic.gov.lk/gic/index.php/en/component/info/?id=2254&catid=16&task=info>

Anon., 2011. Annual Report of the University Grants Commission, s.l.: University Grants Commission of Sri Lanka.

Anon., 2013/2014. Admission to undergraduate Courses of the Universities in Sri Lanka. s.l.:University Grants Commission of Sri Lanka.

Anon., 2014. Statistical Handbook-2013. Nugegoda, Sri Lanka: Open University Sri Lanka.

Anon., 2019. Admission to Undergraduate Courses In Sri Lanka. s.l.:University Grants Commission Sri Lanka.

Anon., 2020. Textbooks to be imported for Sri Lankan curriculum. [Online]

Available at:

<https://opportunitiesrilanka.com/opportunity/textbooks-to-be-imported-for-sri-lankan-curriculum/>

Anon., 2020. University Grants Commission of Sri Lanka. [Online] Available at: <https://www.ugc.ac.lk/en/universities-and-institutes/list.html>

Anon., n.d. CINEC Campus. [Online] Available at: <https://www.cinec.edu/admission.html>

Anon., n.d. ESOFTEC METRO CAMPUS. [Online] Available at: <http://esoft.lk/>

Anon., n.d. General Sir John Kotelawala Defence University. [Online]

Available at: <https://www.kdu.ac.lk/>

Anon., n.d. NIBM. [Online] Available at: <https://nibm.lk/>

Silva, Y. W. & K., n.d. Z-score demystified: a critical analysis of the Sri Lankan university admission policy. Case Studies in Education, p. 18.

UNIVOTEC, n.d. Education Management Information System. s.l.:Science Land Software Solution.

## Author Biographies



W.P.J. Pamarathne completed her BSc in Computer Systems and Networks from the Sheffield Hallam University, UK in 2006. Then, she completed her MSc in Computer and Network Engineering in

2008 from the same University. In 2019, she completed MPhil in Computer Science at the University of Sri Jayawardnepura, Sri Lanka.

Her major areas of interests are swarm intelligence and the internet of things.



Achintha Bandaranayake is currently a BSc. Computer Engineering undergraduate at the Department of Computer Engineering, Faculty of

Computing, in the University of General Sir John Kotelawala Defense University

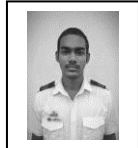

Aditha Iddamalgoda is currently a BSc. Computer Science undergraduate at the Department of Computer Science, Faculty of Computing,

in the University of General Sir John Kotelawala Defense University



Madhuka Bandara is currently a BSc. Computer Engineering undergraduate at the Department of Computer Engineering, Faculty of Computing, in the University of General Sir John Kotelawala Defense University



Achini Kalhari is currently a BSc. Computer Science undergraduate at the Department of Computer Science, Faculty of Computing, in the University of General Sir John Kotelawala Defense University



## IMAGIBOT – An Image Recognition Chatbot for Sri Lankan Ancient Places

P J Senevirathne<sup>#</sup> and D U Vidanagama

*General Sir John Kotelawala Defence University, Sri Lanka*

<sup>#</sup>pabodasenevirathne@gmail.com

**Abstract:** Ancient artifacts of Sri Lanka are used as major sources of getting historical information about Sri Lanka. Acquiring the necessary information about those artifacts become a huge challenge for the visitant of artifacts. Text based search engines are typically used to retrieve information about ancient artifacts of Sri Lanka. These systems require the user to formulate a text query that provides information such as the place, where the object is placed or where does that can be found, what is the century object belonged. Oppositely visual search systems can be used. They provide information to users of the system such as scholars, tourists, local explores in a most intuitive and immediate way by using an image as a query. This research involves in developing a chat application along with Convolutional Neural Networks for image recognition of ancient artifacts. The image recognition model will be a part of the chat bot that has ability to retrieve more information about recognized images. Convolutional Neural Networks, Recurrent Neural Network, TensorFlow, Keras have been used as core technologies in this research project. As the research involves in developing a chat application with image recognition capabilities, the application will improve the knowledge sharing of Sri Lankan ancient legacy to the word in an effective way.

**Keywords:** Chatbot, Convolutional Neural Networks, Ancient Artifacts, LSTM

### Introduction

The sacred places like Anuradhapura, Polonnaruwa and Kandy in Sri Lanka, taking more attraction among tourists from different countries because of rich diversity of ancient Sri Lankan culture and architecture. Those can be considered as major centres of Sri Lankan civilization.

Sri Lankan history is started in 5th century B.C with the first settlement that make by Indo Aryan who came from north India in this land. After that Sri Lanka had a continuous settlement and Sri Lanka has continued records about all those things too. That is the reason that Sri Lanka has a great documented history. Those things have added a great value to Sri Lanka.

As many peoples tending to visit ancient places in Sri Lanka with a high value in order to find out historical information for their research purposes, there are some difficulties that they are facing when gather information about those ancient things. Lack of organization of description demonstrations, reading long historical descriptions that has kept in front of ancient artifacts in a busy time schedules in a limited time periods, Sometimes, having some images of ancient things that don't have its identification and related information are some of them. In such situations, sometimes they have to move around more web sites and historical sources, in order to gather historical information.

Technology related with machine learning, image recognition has become a mandatory

thing in worldwide and those technologies has already applied in travel and education industries. But in Sri Lanka there are not many automated systems that deal with Artificial intelligence in image recognition.

To make better knowledge sharing among tourists and local people about ancient legacy of Sri Lanka, an intelligent chatbot (ImagIBot) system can be designed and developed. The system will introduce a chatbot as a human-computer dialog system to communicate between user and device by using both image and text as a query.

By using this intelligent chatbot system called ImagIBot, has image recognition capabilities and users can chat with a real time bot more efficiently to gain knowledge about those historical artifacts. For that, system will allow users to insert a photo of a historical place or artifacts easily to the chatbot, which they have. Thought the chatbot user can easily ask what they want to know about the artifact in the image, instead of reading all details of them by searching through many web sites, books or in other historical sources.

System will help to all foreign and local travellers to find out places more efficiently through the chatbot, and this will be a real time experience that they can gain by the chatting with a chatbot. It will be able to give accurate information and locations on a particular historical heritage and save the time of users by providing necessary information according to their information requirements by eliminating reading long stories and historical information searching by moving into many web sites.

This will be a good experience with improved user service, better engagement, keeping up with the trends by being present on messaging platforms, user satisfaction and time savings.

Apart from those the chat bot have the ability to do chat escalation to a human agent when

necessary, store user queries that it cannot identified in real time chat for future training, spelling correction abilities, ability to upload images easily. The information that the system provides will make user to work efficiently and leads to enhancement in performance in their searching purposes with more efficiency. As business verticals, the system can be successfully used in Travel and Education industries.

Through the paper will present design and implementation of the system. Section 2 of the paper describes overview of some existing chatbot systems. Section 3 continues the Methodology of the system; section 4 continues with the evaluation and section 5 continues with the discussion. Finally, Section 6 draws together a conclusion of the work done and discusses future research directions.

### Literature Review

Chatbot is a program designed counterfeit a smart communication on a text or spoken ways. Those chatbots are widely popular in the world. And they are responding intelligently like human. (Dahiya , 2017). Those give an automatic reply to human what they are looking for. Not only that chatbots has capability to interact with users using natural language processing. Because of that that chatbots can be used as a tool of entertainment such as pandorabots and ELIZA. In this way chatbots can be used as a,

Tool of entertainment

Chatbots can be used as a tool to learn and practice a language.

It can be used as an information retrieval tool.

Can be used as assistants in E-Commerce, business and in other domains. (Shawar & Atwell, 2007)

Today there are many conversational agents (CA) such as Siri, Google Assistant and Alexa. Not only that Cortana, Pandrabots, Burberry are found on Messenger, Slack, or in Skype.

The first chatbot was emerged in 1996 from MIT. That is called ELIZA that worked on simple declarative rules. The follow up chatbots include ALICE, Elizabeth, Loebner winners such as Mitsuku, Rose etc. Artificial Linguistic Internet Computer Entity (ALICE) is an award winning chatbot that available as open source that has developed using AIML (artificial intelligence Mark-up Language) (Jain, et al., 2018). And this was developed by Dr. Wallace and ALICE uses simple pattern machine algorithm. (Bani & Singh, 2017)

The GUS stands for the Genial Understander System, can be describe as the first experimental computer system that did in language understanding. It is also able to conduct a more or less realistic dialogs within some limitations which is a frame driven dialog system. Figure 1, shows a transcript of an actual dialog of GUS. There are some problems of the natural dialogues such as,

- i. Mixed initiative
- ii. Indirect answers

```
GUS: Hello. My name is GUS. I can help you plan a simple trip by air.
Where do you want to go?
(1) Client: I want to go to San Diego on May 28
GUS: What time do you want to leave?
(2) Client: I must be in San Diego before 10 am
GUS: Would you like P.S.A. flight 102 that arrives at 9.15 am?
(3) Client: What is the next flight?
GUS: Air California flight 310 that leaves at 8.30 am and arrives at 10.00 am
(4) Client: I'll take the first one
GUS: In what name should I make a reservation, please?
(5) Client: Dan Bobrow
GUS: I have confirmed the following flight:
P.S.A. flight 102 on Wednesday May 28 from San Jose to San Diego
that leaves at 7.30 am and arrives at 9.15 am.
What date do you want to return on?
(6) Client: On Friday in the evening.
GUS: Would you like the flight that leaves at 7.45 pm?
(7) Client: That's fine.
GUS: I have confirmed the following flight:
P.S.A. flight 307 on Friday May 30 from San Diego to San Jose
that leaves at 7.45 pm and arrives at 9.30 pm
Thank you for calling. Goodbye.
```

Figure 25: A transcript of an actual dialog with GUS  
Source: GUS, A frame driven dialogue system (1976)

It uses Frames that can be used in reasoning component and they can used to represent collections of information at many levels within their system. Not only that, frame is a data structure that potentially contain a name, reference to a prototype frame and set of slots. Apart from that it follows a simple depth-first, recursive process. That means it

systematically completing work on a given slot before continuing to the next. This is the way of GUS attempts to retain the initiative in the dialogue. GUS is not very intelligent itself, but it illustrates what that is believed to be essential components of such system. (Bobrow, et al., 1976)

The research paper written by Vladimir Vlasov represented a dialogue policy based on transformer architecture and compares the performance of Transformer embedding Dialogue that knows as TED policy to LSTM and to REDP in order to overcome the limitations of RNN. Recurrent neural networks (RNN) are used in both open domains and task-oriented systems in order to process the sequence of previous dialogue turns in recent years. (Vlasov, et al., 2019)

When designing a chatbot, open source languages such as AIML and Chat Script can be used. They can be introduced as the mostly used open source languages that used to design chatbots. AIML is an XML based mark-up language and it is the most used chatbot language because of its simplicity. Chat Script is a scripting language and it can accept user text input and generate a text response that help to manipulating natural language. (Arsovski & Muniru, 2017)

There are two types of dialogue systems. They are,

- i. Goal driven systems – Ex: support services
- ii. Non goal driven systems – Ex: language learning tools/computer game characters.

Slot filling techniques can be use in rule-based approach such as Siri that proven to be reliable. Because in rule base approach chatbot answers questions based on rules on which is trained on. But in some cases, bot is not efficient in answering questions when pattern is not match with the rules of the bot that has trained. The purpose of that is the

bot that functioning efficient than rule base approach. Because end to end trainable memory can enhanced neural networks architecture. (Thomas & Thomas, 2018)

As museums and galleries have track records, it is experimenting new ways to reach their audience with the use of emergent technologies. Emerging free chatbot creating platforms such as chatfuel, chatterbot, Eliza enable opportunity to be experimenting with chatbots with low effort, low cost and keeping staff resources at a low level. There are many numbers of museums that using bots to engage their audience with new technologies. Some of museums that uses chatbots are listed below,

- i. Heinz Nixdorf Museums Forum - The Heinz Nixdorf MuseumsForum in Paderborn Germany has an early experience of using an avator bot introduced as MAX. Developed in 2004, It directly engages with visitors through a screen as a virtual museum guide.
- ii. San Francisco Museum of Modern Art (SFMOMA) - Send Me SFMOMA is an SMS service that provides an approachable, personal, and creative method of sharing the breadth of SFMOMA's collection with the public (Boiano, et al., 2018)

CNN is a most impressive forms of ANN (Artificial neural networks) that primarily use to solve difficult image driven pattern recognition. Artificial Neural Networks (ANN) are mainly comprised of high number of interconnected computational nodes. Those have two types of learning methods such as,

- i. Supervised learning - supervised learning is the learning through pre labelled inputs, which act as targets.
- ii. Unsupervised learning - unsupervised learning is different

form it does not include any labels for learning.

The only different between convolutional neural networks and artificial networks are CNN is mostly used in field of pattern recognition within images. (O'Shea & Nash, 2015)

Large deep convolutional neural networks can have good results in image classification, but those image classification needs methods to reduce and prevent the over fitting. In past neural networks are not used in Computer vision because it needed more computational power in order to train and need lots of labeled data too. But today fast GPUs and big labeled image datasets can be used in order to solve these problems. (Smirnov, et al., 2014). Figure 2 shows the architecture of a deep convolutional neural network.

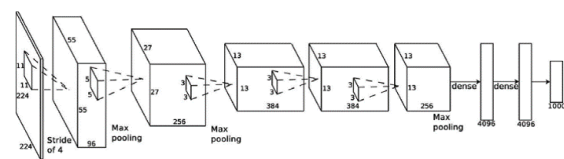

Figure 26: Deep convolutional neural network  
Source: ImageNet (2014)

There are traditional machine learning methods like multilayer perception machines, support vector machine. But today CNN has become more powerful and universal deep learning mode. Because CNN can be identified as a multilayer neural network, it is a most classical and common deep learning framework and it has excellent performance in field of hyperspectral image classification. Because of all those things convolutional neural networks has been more effective in image processing when considering traditional machine learning methods. (Xin & Wang, 2019)

### Methodology

The section describes the methodology of the system. This research project aims to build an image recognition model in order to

classify ancient images of Sri Lanka using convolutional neural networks and combine it with a chatterbot. This will provide best quality information to user.

The inputs for this automation process are images and texts. First user will be uploading the historical images to the chat interface and through the image recognition model developed using CNN will recognize the ancient artifact. After that it will send the related name to the user through the chat interface. Then user can chat with the ImagIBot and ask more related information about those ancient artifacts of Sri Lanka.

Furthermore, chatbot system can do some small operations such as have the ability to do chat escalation to a human agent when necessary, ability to upload images, store user queries that it cannot classify in real time by the chat modal (finally, those queries uses for future training), spelling correction abilities etc.

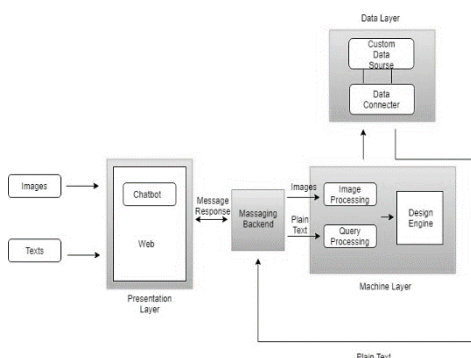

Figure 27. Overall ImagIBot system architecture  
Source: Author

As programming methodology, Extreme programming has been used, because it is an Agile software development framework that helps to provide high quality software. The main reason for that is Extreme programming helps to dynamically changing requirements.

The overall system architecture is lies between three main architectural layers that can be called,

- i. Presentation layer
- ii. Application layer

### iii. Database layer

When look by the architectural perspectives that shows in figure 3 , it is very critical task to identify and acknowledge the workflow of each layer in order to design the system accordingly and correctly.

#### A. Presentation Layer

Presentation layer is the layer where the user directly interacting with the ImagIBot. Front end of the system includes all the interfaces of the system. HTML5, CSS3, JavaScript, Bootstrap along with the Angular Framework has been as front end technologies.

#### B. Application Layer

Application layer, if not the machine learning layer of the proposed system is designed with the two main modules. This is the layer which all the image classification happens. This layer will execute all the main goals of the system. The two separate modules in this application layer are named as,

- i. Chat module
- ii. Image recognition module

##### 1) Chat Module:

The chat module is the part that handles all the user queries. If query is a text, the chat module takes text as the input and it will understand the intent of the sentence. If query is an image the chat module will send it to the image classification module that have developed using CNN. When user enter the query in text format, it first classifies the intent of the user query and then extract entities such as artifact place, opening hours, creator, only if entities are visible in the user query. The GUS (Genial Understander System) is used as the concept behind the chatbot. As GUS is a frame driven dialog system. GUS has ability to conduct a more or less realistic dialogs within some limitations. The Frames are used in the chatbot module because frame is a data structure that

potentially contain a name, reference to a prototype frame and set of slots. (Bobrow, et al., 1976).

As an Example ,When a user asks, "What is Sigiriya",the intent will be "asking about an ancient artifact" and the entity will be the "Sigiriya". Internally the model uses the bag of word (Bow) algorithm to find the intent of the user and Conditional Random Field (CRF) to find entities of the user inputs. A python library known as pypellchecker has used to create a custom dictionary for the ImagiBot in order to correct spelling of user text queries before classifying the intent. Otherwise meanings of the text queries can be change because of misspellings.

According to chat bot architecture presented, user has ability to enter query in both text and the image format. When user insert an image to the ImagiBot, it will classify the image using image recognition module and it will send the name of the artifact in the image to the chatbot module. After that the artifact name will be saved in a slot of a chatbot module for further usage. Finally, user can ask more information from the chatbot.

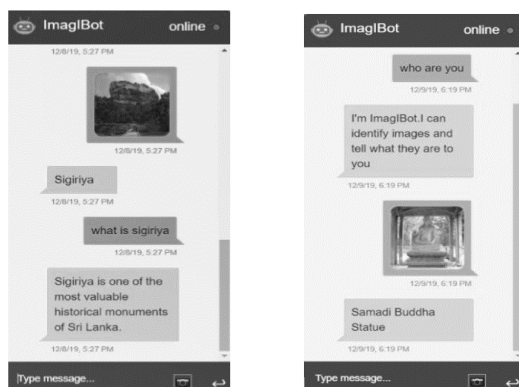

Figure 28: Successful image recognition and some conversations of the ImagiBot

When chatbot need some information from database, it calls the database connection according to the slot that filled with artifact name and retrieves necessary data from database. When making utterances those data will be used. Python Flask has been used for connecting components tighter in the ImagiBot. As initial step, Rasa (A open source

machine learning framework) has been used to develop the AI assistant. (Vlasov, et al., 2019)

## 2) Image Recognition Module:

Image recognition model recognizes all the images that user uploaded to the ImagiBot. It has ability to identify images only belongs to the Sri Lankan ancient legacy. It is totally based on a model that developed using Convolutional Neural Networks. As a class in deep learning neural network, convolutional neural networks can be identified. The image recognition model of the ImagiBot has been developed using CNN, because it has ability to differentiate images one from the other. Not only that CNN model will have capability to send fallback message to user, if the probability of being a Sri Lankan artifact is low or if it is not in the ImagiBot's domain. Steps used to develop CNN model is as follows,

**Convolutional Layer** – The convolutional layer of the system will make use of a set of learnable filters in convolutional neural networks.

**Pooling Layer** - This layer is located between convolutional layers in CNN architecture. This reduces the number of parameters and computation in the network. And most importantly, it controls the overfitting. This is done by progressively reducing the spatial size of the network.

**Max pooling** – Max pooling has used as a noise suppressant because it takes out only the maximum form the pool. This layer is also responsible in order to reduce spatial size of the convolved feature.

**Flattening** – This is a very important layer in the image recognition model because it is used to convert images in to 1 dimensional array that is used for the inputting that to next layer. This create a single long feature vector. Apart from that this layer is

connected to the last classification model that is known as fully connected layer.

Fully Connected Layer - In fully connected layer all neurons have complete connection to all the activations from the previous layers.

Apart from that 'categorical\_crossentropy' has used for the multi class classification in image recognition. 'relu' and 'softmax' has been used as activation functions. In this way Convolutional neural network are made up of hidden layers and the fully connected layers. TensorFlow has been used in CNN in following purposes, some of them are listed below,

- i. Preprocess the images that is in the dataset
- ii. Create placeholders in the model
- iii. In order to Combine all functions into a model

Keras has designed to enable to do fast experimentation with deep neural networks, When developing CNN model,

- i. Keras library is very helpful in making that model in a simple way
- ii. Keras is very useful in training the model in better way
- iii. Used for data preprocessing
- iv. Most importantly, it has been Used ImageDataGenerator class for generate batches of tensor images with the real time data augmentation in the CNN model.

### C. Database Layer

This layer is all about managing the database of the system developed using MySQL database. Because of that this layer is responsible for managing all database requirements of the system.

## Evaluation

The system can be evaluate using following measures. The system has good comprehension capabilities, because ImagiBot ensures good texting and error free experience of the user by using 'spelling correction' feature. This helps to improve the accuracy of the intent classification of text and give most meaningful reply to the user. As the system has rich data set and use of best hyper parameters such as activation functions, best number of convolutional layers and best number of nodes in each convolutional layer will increases the performance of the image recognition model. Not only that ImagiBot has good user engagement, because it has capability to initiating conversations with users and interact with them in order to share information with users more effectively. ImagiBot has programmed with capability to fetch image and text query quickly and respond quickly. Because of that the system will respond to the user quickly and will increase the user satisfaction. The accuracy of the image classification model has been calculated as follow,

<b>True Positive(TP)</b> Number of TP results: 1	<b>False Positive(FP)</b> Number of FP results: 1
<b>False Negative(FN)</b> Number of FN results: 8	<b>True Negative(TN)</b> Number of TN results: 90

Figure 5: Accuracy of the Image Classification model of the ImagiBot

Source: Author

$$Accuracy = \frac{\text{Number of correct predictions}}{\text{Total number of predictions}}$$

$$Accuracy = \frac{TP + TN}{TP + TN + FP + FN} = \frac{1 + 90}{1 + 90 + 1 + 8} = 0.91$$

The 0.91 or 91% accuracy comes out from the image recognition model outputs 91 correct predictions out of 100 total examples. Not only that the system will have may functionalities and it can be scalable for additional modules and other domains

easily. Finally, ImagIBot has used rich media images and text in order to get user's attention.

### **Discussion**

ImagIBot is a chatbot that have image recognition capabilities. It has been developed with the trending artificial intelligent algorithms such as convolutional neural networks, Bow, CRF and Recurrent neural networks. The system is gives ability to user to upload images that belongs to the ancient Sri Lanka. After that it will identify all those images and tell the user what is that artifact is. At the end of that process user can chat with the real time bot developed and get knowledge about those ancient artifacts.

The system is helpful to many people such as foreign tourists, school children, teachers, local travelers, and for ancient artifact explorers, when they search information about Sri Lankan ancient history by visiting some museums, ancient places, temples etc. They can easily take a photograph of an artifact and upload it to ImagIBot in order to find information about particular artifacts. It will be a good solution for problems that occurs in those places, when gather information about ancient artifacts. The system has ability to give accurate information about historical heritage also. Because of that ImagIBot saves the time of users by providing important information according to their information requirements by eliminating reading long stories and historical information searching by moving into many web sites. Because of that users can use this Intelligent system for gain knowledge and find important information about Sri Lankan ancient artifacts and places.

Finally, this system will be a valuable and efficient system to the people those who visit and the search about ancient legacy of Sri Lanka. Not only that information that the system provides will make user to work efficiently and leads to enhancement in

performance in their searching purposes of ancient historical artifacts of Sri Lanka. The system can implement in Sri Lankan museums as part of their audience engagement program.

### **Conclusion and Further Work**

This paper presented design and implementation of a Chatbot system, which is designed as a human-computer dialog system. Through the development process start to end, it has been successful enough to meet main requirements of the image recognition chatbot in order to recognize ancient places and artifacts. This will helpful to share ancient legacy of Sri Lanka more effective way using Artificial Intelligence. Not only that, As business verticals, the system can be used in Travel and Education industries world widely. But it does not mean that the system cannot improve it domain, technologies and new functions further.

Today technologies are growing faster and with the growing of those technologies there can be done many enhancements to the ImagIBot. Some of them have listed below that can be done within a short period of time with the technology enhancements. Add Context switching capabilities, Integrations with the Alexa, add multilingual supports like Sinhala language are some of them. Based on chat history sentimental analysis can be done regarding user satisfied or not by chatting with the ImagIBot. Not only that the ImagIBot can be integrated to other channels such as WhatsApp, Facebook Messenger or in Slack. The process of the chatbot system will be much transparent to the user. That will be easier to incorporate any development in early states of the use of the chatbot system.

### **References**

Arsovski, S. & Muniru, I., 2017. ANALYSIS OF THE CHATBOT OPEN SOURCE LANGUAGES AIML AND CHATSCRIPT:A REVIEW. p. 8.



Bani, B. S. & Singh, A. P., 2017. College Enquiry Chatbot Using A.L.I.C.E. International Journal of New Technology and Research (IJNTR), 3(1), p. 2.

Bobrow, D. G. et al., 1976. GUS, A Frame-Driven Dialog System. p. 19.

Boiano, S. et al., 2018. Chatbots in museums: hype or opportunity?. p. 12.

Dahiya , M., 2017. A Tool of Conversation: Chatbot. INTERNATIONAL JOURNAL OF COMPUTER SCIENCES AND ENGINEERING , 5(5), p. 5.

Jain, M., Kumar, P., Kota, R. & Patel, S. N., 2018. Evaluating and Informing the Design of Chatbots. p. 12.

O'Shea, K. & Nash, R., 2015. An Introduction to Convolutional Neural Networks. p. 11.

Shawar, B. A. & Atwell, E., 2007. Chatbots: Are they Really Useful?. p. 22.

Smirnov, E. A., Timoshenko, D. M. & Andrianov, S. N., 2014. Comparison of Regularization Methods for ImageNet Classification with Deep Convolutional Neural Networks. s.l., s.n., p. 6.

Thomas, J. S. & Thomas, S., 2018. Chatbot Using Gated End-to-End Memory Networks. International Research Journal of Engineering and Technology (IRJET), 5(3), p. 6.

Vlasov, V., Mosig, J. E. M. & Nichol, A., 2019. Dialogue Transformers. p. 7.

Xin, M. & Wang, Y., 2019. Research on image classification model. EURASIP Journal on Image, p. 11.

### **Acknowledgment**

The paper is made possibly thought the help and support from my parents, lectures, family and friends. It is pleasure to present the research paper on an Image recognition chatbot for Sri Lankan ancient places. The opportunity will be taken to thank Senior lecturer Mr. Ruwan Pathum Kathriarachchi Head of Information Technology department, General Sir John Kotelawala Defence University, for giving all the help and guidance needed. Kindest blessings to everyone who gave the zeal and faith to put

forward this work and I would like to express my gratefulness to them.

## Survey on Deep learning based Network Intrusion Detection and Prevention Systems

MAT Padmasiri, VVV Ganepola, RKHMSD Herath, LP Welagedara, GANS Ganepola and P Vekneswaran#

*Informatics Institute of Technology, No.57, Ramakrishna road, Colombo 06, Sri Lanka*

#veknesp@westminister.ac.uk

**Abstract:** Where world is moving towards digitalization, it is crucial that network intrusions detection and prevention is addresses in ordered to create a secured network. This paper covers why deep learning was considered and what are the deep learning approaches for network intrusion detection. For each approach the challenges, missed elements and the unique features that are found in current domain state are also highlighted. As a conclusion this paper highlights why CNN and LSTM would be successful approach for intrusion detection and why in the current domain context it is required to create scalable solution with both intrusion detection and prevention involved.

**Keywords:** Network Intrusion Detection and Prevention System, Deep Learning, NSL-KDD

### Introduction

Introduction and evolution of network technologies in the past decades have resulted in a massive growth in Internet technologies. As a result, the ways for intruders to tamper and obstruct the consumers in their day to day network-based activities have increased as well. (Alom, Bontupalli and Taha, 2015) Intrusive behavior is when the confidentiality, integrity and availability of a network resource is exposed and hindered to its intended user. Network Intrusion Detection and Prevention System (NIDPS) come into the picture when providing a defense against any activity that compromises the three

factors mentioned above. It can be classified into two categories based on the deployment (Samrin and Vasumathi, 2017) location.

- Host Intrusion Detection System (HIDS)
- Network Intrusion Detection System (NIDS)

HIDS (e.g. Commercial Anti-Virus Software) is deployed in its host and is capable of processing specific data. (i.e. Operating System's audit trails and system logs). HIDS suffers from high resource usage leading to performance drop in the host machine. NIDS on the other hand, performs better being deployed as an external access point.

NIDS is extended further to use Anomaly Detection and Signature Based Detection. Anomaly Based Detection is the analysis of network data to classify whether the data is intrusive (anomaly) or non-intrusive(normal). Signature based detection is based on prior knowledge, where unique patterns of intrusions are generated and updated for intrusion detection daily.

Paper "Machine Learning Based Novel Approach for Intrusion Detection and Prevention System: A Tool Based Verification" specifies that current research lacks explanation of proactive measures that are taken to handle Denial of Service intrusions (Chandre, Mahalle and Shinde, 2018). Paper "Adaptive Fuzzy Neural Network Model for intrusion detection" highlights that the domain lacks a solution which can handle a large flow on network data and detection, hence it is required to

focus on a scalable solution. (Kumar and Mohan, 2014)

### Methodology

The paper aimed at analyzing existing research of the domain in order to gain the domain knowledge and understand the current state of the domain. Existing research has been analyzed based on different machine learning paradigms such as deep learning, shallow learning and autoencoders. It was done to understand the current domain context and therefore to identify which approach suits more for intrusion detection. This information would be elaborated further in section III. In this paper, existing approaches based on Supervised and Unsupervised learning have been discussed mainly. Different algorithms falling under these 2 categories are extensively researched to arrive into the conclusion.

### Related Works

When analyzing related works, it is required to understand the relevant datasets that are being used in the context of the domain and what data science approaches were used.

#### A. Datasets in the domain

There are several datasets that were identified in the analysis such as NSL-KDD, UNSW-NB15, KDD CUP 99, CICIDS2017, CTU-UNB, CIDDS-001 etc. Out of them, NSL-KDD was widely used across the research. NSL-KDD (Alom, Bontupalli and Taha, 2015) dataset is an improvement of KDD CUP 99 dataset, which has solved some issues such as duplication of data and such as in its predecessor. NSL-KDD dataset provides 41 attributes depicting different features in network flow. 125973 and 22544 records are available on NSL-KDD training and testing dataset respectively. NSL-KDD dataset's (Rama Devi and Abualkibash, 2019) 42<sup>nd</sup> feature which would provide the

class specifying if it is a normal class or the attack type class which are mentioned below.

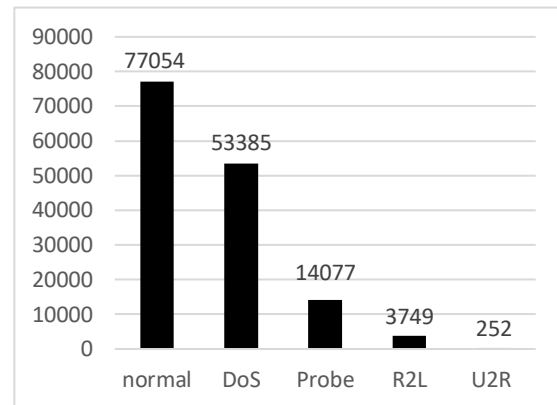

Figure 1: NSL-KDD dataset

“Intrusion detection using deep belief networks” (Alom, Bontupalli and Taha, 2015) provides more information relating to each dataset that are available in the current domain such as CICIDS, CAIDA. “Feature selection in UNSW-NB15 and KDDCUP'99 datasets” (Janarthanan and Zargari, 2017) provides details about UNSW-NB15 which is said to provide more features on modern attack types than NSL-KDD.

#### B. Data Science Approaches

This survey is based on deep learning approaches due to certain facts identified during early research. Shallow learning model, the counterpart of deep learning models as mentioned in “A comparison between shallow and deep architecture classifiers on small dataset” (Pasupa and Sunhem, 2016) does not tend to perform well with larger dataset size whereas deep learning models do. “MLSEC - Benchmarking Shallow and Deep Machine Learning Models for Network Security” compares both shallow models and deep learning models where it has showed that deep learning model managed be up to par with other shallow learning models. (Casas et al., 2019) Deep learning models can be either be Supervised or Unsupervised learning approach.

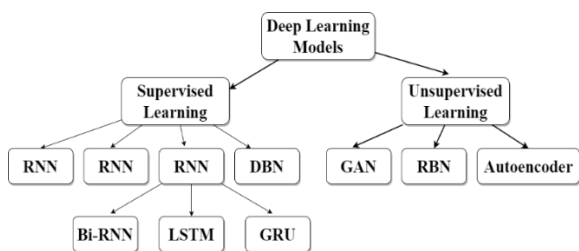

Figure 2: Taxonomy in use of Deep learning in Intrusion Detection

Existing works of Intrusion detection domain can be mainly categorized into two based on the approach.

1) **Supervised Learning:** In supervised learning, the model is trained and validated on a labelled dataset. There, algorithms will understand and learn the data based on patterns. After training the model, it determines which label is to be given for the new raw data based on the patterns identified during the training phase (Alom, Bontupalli and Taha, 2015). Deep Belief Network (DBN), Deep Neural Network (DNN), Convolutional Neural Network (CNN), Recurrent Neural Network (RNN), Long Short-Term Memory (LSTM) and other variations of RNN such as Gated recurrent units (GRU) and Bi-RNN are based on supervised learning.

DBN contains both multiplayer unsupervised network and a supervised network which are Restricted Boltzmann Machine and Back-propagation respectively. "An Intrusion Detection Model Based on Deep Belief Networks" uses a Network Intrusion Detection Model Based on DBN utilizing KDD CUP 1999. Results of this research provides an accuracy of 93.49% and true positive rate of 92.33% and false positive rate of 0.76 (Gao et al., 2014). "Intrusion Detection using Deep Belief Network" research paper utilized NSL-KDD dataset where 97.5% testing accuracy was yielded. (Alom, Bontupalli and Taha, 2015)

"Deep Learning Approach for Network Intrusion Detection in Software Defined Networking", this research paper provides

results of a DNN model using NSL-KDD dataset, accuracies of the proposed model were 75.75% for 5 intrusions class classification. Researchers conclude lower accuracy rate could be as a result of lack of proper features selection. (Tang et al., 2016)

CNN can be used for both feature extraction and network packet classification (Hsu et al., 2019). "Intrusion detection Algorithm Based on Convolutional Neural Network" research paper (Liu, Liu and Zhao, 2018) provided detection rate of 99.96%. Considering "an Intrusion Detection System Based on Convolutional Neural Network" paper proposed a CNN model which used One Hot Encoding (OHE) encoding for feature matrix. One Hot Encoding is where rather than integer encoding where a unique integer is set for each category in categorical data, it provides a binary representation whether the specific category exists OHE provided more stable feature set resulting in 99% detection rate and false alarm rate of the mode low than 0.1%. According to the researcher, One Hot Encoding has improved the feature set which has provided higher accuracies than earlier feature set. (Liu, 2019)

"A Deep Learning Approach for Intrusion Detection Using Recurrent Neural Networks" provides an RNN model for both binary and 5 class classification on NSL-KDD dataset.

68.55% and 64.67% detection accuracies on binary and multi class classifications respectively. (Yin et al., 2017) "Long Short Term Memory Recurrent Neural Network Classifier for Intrusion Detection" paper RNN model proposed a training method (Hessian Free Optimization). (Kim et al., 2016). KDD CUP 99 resulting in accuracy of a 95.37% and false alarm rate was 2.1%. Later RNN was further extended down with improvements, namely those are LSTM, GRU and Bi-RNN (Cui et al., 2018).

Even though results of these models were promising, KDD CUP 99 as mentioned contains redundant data and opting RNN for its improved predecessor LSTM which would be explained below.

As mentioned earlier RNN was improved in solving vanishing gradient and exploding gradient problem, LSTM which can learn long-term dependencies was one of these improvements. (Hsu et al., 2019) LSTM uses activation function layers which act as gates which allows the LSTM to remember previous information. "Long Short-Term Memory Recurrent Neural Network Classifier for Intrusion Detection" (Kim et al., 2016) proposed LSTM-RNN with KDD Cup 99 dataset resulted in 10.08% false alarm rate and accuracy of 96.93%. "LSTM for Anomaly-Based Network Intrusion Detection" (Althubiti, Jones and Roy, 2018) proposed an LSTM model using CIDD5-001 for a multi-class classification which provided results of accuracy of 0.8483 and precision of 0.8514 and false alarm rate of 0.172.

LSTM as said can retain dependencies in its memories, according to the researchers' opinion this feature should be very valuable in a network intrusion domain where varying packers could flow and ability to retain its patterns should provide a performance gain. The above statement could be verified in a real-world end to end product which can capture live traffic and detect intrusions through said model but referenced research doesn't provide any implementation of such.

2) Unsupervised Learning: Unsupervised is based on unlabeled data, these algorithms work without any pre known Dataset (Rama Devi and Abualkibash, 2019). Autoencoders, Generative Adversarial Network (GAN) and Restricted Boltzmann machine (RBN) algorithms analyses how unsupervised learning was utilized in detection.

"Network Anomaly Detection with Stochastically Improved Autoencoder Based Models" (Aygun and Yavuz, 2017) specifies that Autoencoders can be categorized further down as stacked, sparse and denoising autoencoders and autoencoders relies on encoding and decoding phases in classifying. Above mentioned research proposed denoising autoencoder based on NSL-KDD which has resulted accuracy of 88.65%." Network Intrusion Detection through Stacking Dilated Convolutional Autoencoders" (Yu, Long and Cai, 2017) proposed method was a convolutional based autoencoder model which used CTU-UNB dataset. This approach has shown capability in processing huge volume of traffic data with 98.62% accuracy. As mentioned, the above research has addressed the issue in handling large network volumes, which was not addressed or considered in other researches.

"Efficient GAN-Based Anomaly Detection" (Zenati et al., 2019) proposed a GAN model which relies on generator (ability to generate data) and discriminator (verifying and validating generated data based on real data) concept in classifying which provides a precision of 0.92, recall and F1 score of 0.9582 and 0.9372 respectively. While considering the analysis on unsupervised algorithms such as GAN and Autoencoders there weren't ample research available. It is believed that due to the availability of multiple datasets supervised learning can be adapted easily and that it would be reliable to use a dataset which already provides intrusions rather than relying on an unlabeled approach with unsupervised learning.

Boltzmann machine (BN) is a bi-directional connected network probability processing unit. In BN each node can be categorized as visible or hidden. Visible nodes represent components of surveillance. Hidden nodes gather dependencies between the visible

node that cannot create pairwise interactions between visible nodes. In BN learning process is too slow to be utilized in real-world applications. A class of narrow connectivity in BNs that has newly gained widespread attention is the Restricted Boltzmann machine (RBN). In RBN each hidden node is only connected to visible nodes. (Aldwairi, Perera and Novotny, 2018). When considering “An Evaluation of the Restricted Boltzmann Machines as a Model for Anomaly Network Intrusion Detection” research paper evaluates the RBM machine learning model for a NIDS. To test this, researchers have used contrastive divergence (CD) algorithm and persistent contrastive divergence (PCD) algorithm. ISCX dataset using for validation, perform training and testing. According to a research result for CD and PCD were respectively as follows 88.6% and 89.7% as accuracy. 88.4% and 84.2% for the true positive rate. (Aldwairi, Perera and Novotny, 2018)

### C. Notable Existing Research Analysis

Considering the above findings, furthermore relevant researches were scoped down that has shown promising results for network intrusion detection which were analyzed and summarized below.

Table 1: Notable Existing Research Analysis

LSTM for Anomaly-Based Network Intrusion Detection (Althubiti et al., 2018, p1-3)	Method	Model was evaluated using CIDDS 001 dataset which contains data from 13 features. Data from 10 of those features were used in this study. LSTM model was composed with input layer of 10 neurons corresponding to the 10 features, a hidden layer with 10 neurons and an output layer with 5 neurons. The hyper parameters set includes 0.01 learning rate, 6 hidden layers, 200 epochs and a batch size of 500 has being used. For this model optimizer called “rmsprop” has been used which is suitable for large datasets and efficient calculations. An Algorithmic comparison was performed using Precision, Recall, False positive rate (FPR) and Accuracy.
	Results	LSTM achieved 0.8713 training accuracy and 0.8483 testing accuracy. SVM, NB and MLP gained testing accuracy 0.7942, 0.7756, 0.8124 respectively. In LSTM FPR was higher than SVM and Naive bayes. LSTM performed well compared to Precision, Recall, Accuracy.
	Review	LSTM is a modified version of RNN which has resolved gradient descent problem. When compared with other Machine Learning models it is having the ability to learn long-term dependencies. In the research LSTM has performed better than SVM, Naive Bayes and MLP of large part due to its ability of learning long-term dependencies.
Using Long-Short-Term Memory Based Convolutional Neural Networks for Network Intrusion Detection (Hsu et al., 2019)	Method	Researchers have proposed two deep learning models that they have evaluated on NSL-KDD dataset. First model is a LSTM model and the other is a CNN-LSTM model.
	Results	CNN-LSTM model achieved higher accuracy compared to LSTM model for both binary classification and multiclass classification. Binary classification using KDDTest <sup>+</sup> LSTM achieved an accuracy of 89.23% whereas the multi-class classification achieved 87.53%; KDDTest <sup>-21</sup> binary and multiclass classification achieved an accuracy of 74.77% and 68.78% respectively. CNN-LSTM model achieved an accuracy of 94.12% and 88.95% for binary and multiclass classification. Using KDDTest <sup>+</sup> Binary and multi-class classification achieved an accuracy of 79.37% and 70.13% for binary and multiclass classification. Both proposed models performed better than benchmarked RNN-IDS model.
	Review	CNN has been used for extracting feature vectors and passing it to the LSTM model as the input of the LSTM model. In this research, CNN has been used to learn spatial features in the data and LSTM has been used to learn temporal features.
A Deep Long Short-Term Memory based classifier for Wireless Intrusion Detection System (Kasongo and Sun, 2019)	Method	This DLSTM approach is compared to Feedforward Deep Neural Networks (FFDNNs), ANN, SVM, KNN, NB and RF. They have used NSL-KDD as the dataset and 18 features were selected.
	Results	DLSTM model achieved validation accuracy 99.51%, F1 score 99.43% and test accuracy 86.99% Model outperformed the LSTM-RNN IDS in “An Intelligent Network Attack Detection Method Based on RNN” (Fu et al., 2018) that had an accuracy of 97.52% on training data whereas the DLSTM RNN IDS achieved 99.51%.
	Review	In this research, they have done experiments between some of the shallow models and some deep DLSTM outperformed compared to all other models experimented in this solution. Based on the information revealed from the existing research analysis, DLSTM outperformed because of the algorithm logic and the structure. As per analysis, this model outperformed some of the other LSTM models like “An Intelligent Network Attack Detection Method Based on RNN” (Fu et al., 2018) due to the structure of the LSTM model. It consists of one LSTM layer and DLSTM model of this research consists of more than two LSTM layers such as three hidden layers.

#### D. Mitigation Approaches

Mitigation approach highlights the currently known and used approaches acting as a prevention mechanism for NIDPS. “A Practical Network-Based Intrusion Detection and Prevention System” model relies on Iptables Linux based tool that act as a firewall which can provide block and unblock rules for the system, hence after the detection it should either drop the packet or block the source IP address and port using IP Tables. (Wattanapongsakorn et al., 2012)

As mentioned, most of the research that was analyzed, did not contain a fully fetched end to end product which could be adapted to real world, hence few of the above said approaches were found in mitigation logics.

#### Conclusion

Above survey provides an overview of Deep learning models which are developed and evaluated on Intrusion Detection and Prevention domain. It is apparent that researched approaches do not focus much attention on proactive measures in prevention and early detection with real time for an end to end solution for the real world. Also, it is important to ensure NIDPS doesn't detect legitimate traffic as intrusions (False Positives) and vice versa the intrusions to be classified as legitimate traffic (False Negative).

Above facts shows that CNN and LSTM seems to provide higher accuracies and provides features such as LSTM being capable of remembering previous knowledge to improve its classifications. It is important to have a high accuracy as in a real-world scenario there would be massive amount of network traffic hence a drop-in accuracy of even 1 percent can reflect massive amount of missed detections. Usage of One Hot Encoding has improved the feature matrix and its stability during preprocessing as mentioned on CNN based model.

The main contribution of this paper is to review the existing research conducted on Network Intrusion Detection and Prevention Systems based on deep learning approaches, thus paving a pathway for researchers to conduct Future Research on this domain conveniently. This has been achieved by an effective classification of deep learning-based approaches, namely supervised and unsupervised learning.

Research has shown that as future work a scalable end to end solution can be implemented to detect and prevent intrusions and cover the drawbacks in this survey. The solution should answer the below mentioned research questions,

Can a machine learning/deep learning model for intrusion detection be used for live network traffic?

Is it possible for a real-time intrusion detection, if not what would be time taken for a detection?

#### Acknowledgment

This research has benefited from numerous researches done prior in this field. We would specifically like to express our gratitude to Mr. Guhanathan Poravi, Mr Sharmilan Somasundaram, Mr. Malinda Kankanage and the faculty of Informatics Institute of Technology for providing expertise and guidance throughout this research.

#### Author Biographies



Prathieshna Vekneswaran ('93) received the B.Eng. Honours in Software Engineering (Sandwich) from IIT, Sri Lanka affiliated with UOW, UK in 2016 and pursued his Master of Science in Advanced Software Engineering in the same, completing it in 2018. He is currently working as a Senior Software Engineer in 99x Technology (Private) Limited, Colombo, Sri Lanka and been lecturing research methods



in various reputed Institutions in Sri Lanka in part time mode.



Avishka Thushan Padmasiri is a final year Software Engineering undergraduate at Informatics Institute of Technology, Sri Lanka. He currently works as a Software Engineer at Pearson Lanka (Private) Limited. He pursues research on Cyber Security and Machine Learning.



Vayangi Vishmi Vishara Ganepola is a final year Software Engineering undergraduate at Informatics Institute of Technology, Sri Lanka. She currently works as a Scholar at Applied Research and Development Team at Pearson Lanka (Private) Limited. She pursues research on Machine Learning and AI.



RKHM Salitha Dilshan Herath is a final year Software Engineering undergraduate at Informatics Institute of Technology, Sri Lanka. He currently works as a Senior Software Engineer (iOS) at Spemai (Private) Limited. He pursues research on Machine learning, Mobile and IOT.



Lahiru Welagedara is a final year Software Engineering undergraduate at Informatics Institute of Technology, Sri Lanka. He currently works as an Associate Software Engineer (Scholar) at IFS R&D International (Private) Limited. He pursues research on Machine Learning, Blockchain, Edge Computing and IOT.



GA Nipuna S Ganepola is a final year Computer Science undergraduate at Informatics Institute of Technology, Sri Lanka. His research interests

include Cyber Security and Machine Learning.

## References

Aldwairi, T., Perera, D. and Novotny, M. A. (2018) 'An evaluation of the performance of Restricted Boltzmann Machines as a model for anomaly network intrusion detection', *Computer Networks*, 144, pp. 111–119. doi: 10.1016/j.comnet.2018.07.025.

Alom, Md. Z., Bontupalli, V. and Taha, T. M. (2015) 'Intrusion detection using deep belief networks', in 2015 National Aerospace and Electronics Conference (NAECON). NAECON 2015 - IEEE National Aerospace and Electronics Conference, Dayton, OH, USA: IEEE, pp. 339–344. doi: 10.1109/NAECON.2015.7443094.

Althubiti, S. A., Jones, E. M. and Roy, K. (2018) 'LSTM for Anomaly-Based Network Intrusion Detection', in 2018 28th International Telecommunication Networks and Applications Conference (ITNAC). 2018 28th International Telecommunication Networks and Applications Conference (ITNAC), Sydney, NSW: IEEE, pp. 1–3. doi: 10.1109/ATNAC.2018.8615300.

Aygun, R. C. and Yavuz, A. G. (2017) 'Network Anomaly Detection with Stochastically Improved Autoencoder Based Models', in 2017 IEEE 4th International Conference on Cyber Security and Cloud Computing (CSCloud). 2017 IEEE 4th International Conference on Cyber Security and Cloud Computing (CSCloud), pp. 193–198. doi: 10.1109/CSCloud.2017.39.

Casas, P. et al. (2019) 'MLSEC - Benchmarking Shallow and Deep Machine Learning Models for Network Security', in 2019 IEEE Security and Privacy Workshops (SPW). 2019 IEEE Security and Privacy Workshops (SPW), pp. 230–235. doi: 10.1109/SPW.2019.00050.

Chandre, P. R., Mahalle, P. N. and Shinde, G. R. (2018) 'Machine Learning Based Novel Approach for Intrusion Detection and Prevention System: A Tool Based Verification', in 2018 IEEE Global Conference on Wireless Computing and Networking (GCWCN). 2018 IEEE Global Conference on Wireless Computing and Networking (GCWCN), Lonavala, India: IEEE, pp. 135–140. doi: 10.1109/GCWCN.2018.8668618.

- Cui, J. et al. (2018) 'WEDL-NIDS: Improving Network Intrusion Detection Using Word Embedding-Based Deep Learning Method', in Torra, V. et al. (eds) *Modeling Decisions for Artificial Intelligence*. Cham: Springer International Publishing (Lecture Notes in Computer Science), pp. 283–295. doi: 10.1007/978-3-030-00202-2\_23.
- Fu, Y. et al. (2018) 'An Intelligent Network Attack Detection Method Based on RNN', in 2018 IEEE Third International Conference on Data Science in Cyberspace (DSC). 2018 IEEE Third International Conference on Data Science in Cyberspace (DSC), Guangzhou: IEEE, pp. 483–489. doi: 10.1109/DSC.2018.00078.
- Gao, N. et al. (2014) 'An Intrusion Detection Model Based on Deep Belief Networks', 2014 Second International Conference on Advanced Cloud and Big Data, pp. 247–252.
- Hsu, C.-M. et al. (2019) 'Using Long-Short-Term Memory Based Convolutional Neural Networks for Network Intrusion Detection', in Chen, J.-L. et al. (eds) *Wireless Internet*. Cham: Springer International Publishing (Lecture Notes of the Institute for Computer Sciences, Social Informatics and Telecommunications Engineering), pp. 86–94. doi: 10.1007/978-3-030-06158-6\_9.
- Janarthanan, T. and Zargari, S. (2017) 'Feature selection in UNSW-NB15 and KDDCUP'99 datasets', in 2017 IEEE 26th International Symposium on Industrial Electronics (ISIE). 2017 IEEE 26th International Symposium on Industrial Electronics (ISIE), pp. 1881–1886. doi: 10.1109/ISIE.2017.8001537.
- Kasongo, S. M. and Sun, Y. (2020) 'A Deep Long Short-Term Memory based classifier for Wireless Intrusion Detection System', *ICT Express*, 6(2), pp. 98–103. doi: 10.1016/j.icte.2019.08.004.
- Kim, Jihyun et al. (2016) 'Long Short Term Memory Recurrent Neural Network Classifier for Intrusion Detection', in 2016 International Conference on Platform Technology and Service (PlatCon). 2016 International Conference on Platform Technology and Service (PlatCon), pp. 1–5. doi: 10.1109/PlatCon.2016.7456805.
- Kumar, K. S. A. and Mohan, V. N. (2014) 'Adaptive Fuzzy Neural Network Model for intrusion detection', in 2014 International Conference on Contemporary Computing and Informatics (IC3I). 2014 International Conference on Contemporary Computing and Informatics (IC3I), pp. 987–991. doi: 10.1109/IC3I.2014.7019811.
- Liu, P. (2019) 'An Intrusion Detection System Based on Convolutional Neural Network', in *Proceedings of the 2019 11th International Conference on Computer and Automation Engineering - ICCAE 2019*. the 2019 11th International Conference, Perth, WN, Australia: ACM Press, pp. 62–67. doi: 10.1145/3313991.3314009.
- Liu, Y., Liu, S. and Zhao, X. (2018) 'Intrusion Detection Algorithm Based on Convolutional Neural Network', *DEStech Transactions on Engineering and Technology Research*, (iceta). doi: 10.12783/dtetr/iceta2017/19916.
- Meena, G. and Choudhary, R. R. (2017) 'A review paper on IDS classification using KDD 99 and NSL KDD dataset in WEKA', in 2017 International Conference on Computer, Communications and Electronics (Comptelix). 2017 International Conference on Computer, Communications and Electronics (Comptelix), Jaipur, India: IEEE, pp. 553–558. doi: 10.1109/COMPTELIX.2017.8004032.
- Pasupa, K. and Sunhem, W. (2016) 'A comparison between shallow and deep architecture classifiers on small dataset', in 2016 8th International Conference on Information Technology and Electrical Engineering (ICITEE). 2016 8th International Conference on Information Technology and Electrical Engineering (ICITEE), pp. 1–6. doi: 10.1109/ICITEE.2016.7863293.
- Rama Devi, R. and Abualkibash, M. (2019) 'Intrusion Detection System Classification Using Different Machine Learning Algorithms on KDD-99 and NSL-KDD Datasets - A Review Paper', *International Journal of Computer Science and Information Technology*, 11(03), pp. 65–80. doi: 10.5121/ijcsit.2019.11306.
- Samrin, R. and Vasumathi, D. (2017) 'Review on anomaly based network intrusion detection system', in 2017 International Conference on Electrical, Electronics, Communication, Computer, and Optimization Techniques (ICEECCOT). 2017 International Conference on

Electrical, Electronics, Communication, Computer, and Optimization Techniques (ICEECCOT), Mysuru: IEEE, pp. 141–147. doi: 10.1109/ICEECCOT.2017.8284655.

Tang, T. A. et al. (2016) 'Deep learning approach for Network Intrusion Detection in Software Defined Networking', in 2016 International Conference on Wireless Networks and Mobile Communications (WINCOM). 2016 International Conference on Wireless Networks and Mobile Communications (WINCOM), Fez, Morocco: IEEE, pp. 258–263. doi: 10.1109/WINCOM.2016.7777224.

Wattanapongsakorn, N. et al. (2012) 'A Practical Network-Based Intrusion Detection and Prevention System', in 2012 IEEE 11th International Conference on Trust, Security and Privacy in Computing and Communications. 2012 IEEE 11th International Conference on Trust, Security and Privacy in Computing and Communications, pp. 209–214. doi: 10.1109/TrustCom.2012.46.

Yin, C. et al. (2017) 'A Deep Learning Approach for Intrusion Detection Using Recurrent Neural Networks', IEEE Access, 5, pp. 21954–21961. doi: 10.1109/ACCESS.2017.2762418.

Yu, Y., Long, J. and Cai, Z. (2017) 'Network Intrusion Detection through Stacking Dilated Convolutional Autoencoders', Security and Communication Networks, 2017, pp. 1–10. doi: 10.1155/2017/4184196.

Zenati, H. et al. (2019) 'Efficient GAN-Based Anomaly Detection', arXiv:1802.06222 [cs, stat]. Available at: <http://arxiv.org/abs/1802.06222> (Accessed: 25 June 2020).

## ATM Detail protection using Geofence Technology

SS Keerthiwardane#, IA Wijethunga

*Department of Computer Science  
Kotelawala Defence University, Ratmalana  
Sri Lanka*

#sahansandeepa96@gmail.com

**Abstract:** GPS technology enable devices to utilize the location information, geofence technology is a novel technology which implement an area with a certain radius and get information through it. This paper represent how we can use geofence technology to improve existing security mechanism relevant to ATM systems. Current security mechanism for ATM system is pin-based authentication. Which doesn't provide expected outcome. It has been currently facing many threats due to fraud activities perform by attackers. Proposed system will provide much more accurate procedure compare to the existing system.

**Keywords:** ATM, Security, Geofence, GPS technology, Android

### Introduction

Rapid growth in banking industry has modified how daily banking procedures are handled. Numerous modern technologies were introduced to cooperate regular banking activities. Automated teller machine (ATM) is one of novel technology which was invented to enhance accuracy and efficiency in banking activities. It is a computerized machine which designed to allocate cash to customers without human interaction ATM are currently using by every single bank around the globe to speed up and improve their banking activities. ATM offer customers ability to conduct some banking activities like withdraw cash, transfer money, and also customers can pay their electricity bills and

telephone bills after official hours. Nowadays, ATM are installed worldwide and people used to interact with them much often to get their works done easily. Main advantage of ATM can also transfer money among several banks and it gives customers chance to withdraw money from their preferred bank.

There are also different aspects that we should need to consider when using ATM. One of the issues which need proper consideration is security because currently the use of ATMs is increasing worldwide and it means that risks of frauds turn into reality more often than earlier. Nowadays there are many persons use modern technological knowledge to steal people's money by performing offensive acts like Skimming attacks, PIN Cracking, Phishing, hacking and lot more. Managing these risks related with ATM fraud made a huge impact in banking industry as well as these acts have become much harder to control because attackers use advanced techniques for them.

Considering about number of security challenges experienced by Automated Teller Machines (ATM) and users and present security procedures in the ATM system has not been able to avoid these challenges so, there is the higher need to improve ATM security system to overcome these challenges. This project study will focus on how to improve security of banking activities in ATM using geo-fencing technology. The main purpose of this project is to develop ATM simulator-based geo-fencing

verification application in order to avoid fraud acts associated with the use of ATM.

Above challenges can only be solved, or at least reduce their impact on banking systems, by using this novel technology. In general, it will help to reduce some of above challenges, also it offers the capability to keep customers private information in a secure way. Existing ATM are using a PIN as their security procedure, this has not been able to prevent crimes related to that because anyone can steal people's money by cracking these Pins. So, it's better to use location-based information as the authentication procedure.

Only after the user verify his location it will give access to the system.

The ordinary pin-based authentication systems do not provide the expected security to the ATM systems. These types of systems can be affected by many problems like lack of individuality, lack of constant representation and awareness to avoidance. Because of these problems, the pin-based systems occurred higher error rate which makes them unacceptable for give security to systems like ATM that require higher security. All these challenges mentioned in above can overcome by using geo-fencing-based systems which is a provide much higher accuracy and effectiveness. to the ATM system.

### **Related Works**

In below mentioned research works on system which use for Atm protection and some systems developed with the help of geo-fencing technology. Biometric is a most mentioned field on ATM detail protection. There were many researches relevant to this field. Also, there're some systems which use SMS based authentication process.

[1] Prof. Selina Oko and Jane Oruh pointed out the security and privacy issues that customer had to face while using current

banking system. The main reason behind introducing this system is to increase security. In this paper they decided to use fingerprint as the Biometric because it offers greater security and convenience than traditional methods. In the proposed system it has three types of users' administrator, bank and customer. Bank register new customers to the system and in the registration process it will capture customers fingerprints. Administrators have the higher access which give them the right to control every procedure happening in the system.

[2] This research work was proposed to avoid limitations in single biometric based systems. The proposed system is about to implement a system using combination of fingerprint and iris identification. System will perform as a multimodal biometric system and record details of iris and fingerprint using sensors. In this study they implemented a code to acquire fingerprints and iris, and then a combination method which is called the two modalities and fusion used to identify those data.

[3] This research works aims to develop a security mechanism for atm system with the help of biometric identification. Fingerprint and iris identification have used as the biometrics. In this system it gives user access if only both fingerprint and iris matched. The purpose of the proposed system is to achieve higher accuracy and also much secure way to protect atm details that may not be enough using a single biometric indicator alone. In the proposed system, it divided the whole process into two stage which are feature extraction and matching stage. Under the matching stage it contain two techniques to get the higher ration for fingerprint and iris match and then system pass those values to the other technique which is about threshold on fingerprint that pass specific number of finger then it use the enrollment iris to derive the matched value for the iris related to this

finger. Afterwards it passes to the fusion equation and get the max fusion and it will give the access to user.

[4] This paper is about the studies on fusion approach to personal identification using iris and fingerprints as biometrics. The study is to study whether the combination of fingerprint and iris biometrics can accomplish performance that is not possible using a single biometric technology. The results of this research study confirm that a multimodal biometric can overcome some of the limitations of a single biometric resulting in a substantial performance improvement

[5] Moses Okechukwu Onyesolu and Ignatius Majesty Ezeani pointed out challenges' customers had to face while using existing banking system because of some loopholes in it. So, they proposed a biometric authentication system using fingerprints. The target population of this study was customers and staff of some banks around Awka, Anambra State, Southeastern Nigeria. Customers were randomly selected for the project.

[6] This Research work proposed to implement a fingerprint matching system which provides reliable and much better performance than the existing systems. The motivation behind this research is higher need to identify a person well because of some current security issues. In this paper system was implemented using with the help of MATLAB codes.

The table below shows a comparison between existing ATM detail security systems and some geo fence-based technologies.

SYSTEM	TECHNIQUE ADOPTED	TECHNOLOGY	LIMITATIONS
Enhanced Atm Security System Using Biometrics [1][1]	Fingerprint biometrics	<ul style="list-style-type: none"> <li>Java Development Kit (JDK)</li> <li>Fingerprint SDK Java 2009</li> </ul>	The system was not implemented as an improvement on the existing system.
Multimodal Biometric system Fusion Using Fingerprint and Iris with Fuzzy Logic [2]	Multimodal Biometric system using Fingerprint and Iris	<ul style="list-style-type: none"> <li>Image Processing</li> </ul>	Take too much time to process these details and required advanced technology for maintenance.
An Enhanced ATM Security System Using Multimodal Biometric Strategy [3]	Fingerprint and iris based multimodal biometric authentication	<ul style="list-style-type: none"> <li>Image Processing</li> </ul>	Din't provide a recommended face recognition algorithm.
Enhanced Automated Teller Machine Using Short Message Service Authentication Verification [7]	SMS Service Verification	<ul style="list-style-type: none"> <li>Google API</li> </ul>	Implemented algorithm only considered a minimum withdrawal amount.
Fingerprint Recognition Using Minutia Score Matching [6]	Fingerprint	<ul style="list-style-type: none"> <li>Image Processing</li> <li>Minutia Extraction using a MATLAB Code</li> </ul>	Fingerprint recognition system did not discuss the local features related to fingerprint verification process
Android Geofencing App for Autonomous Remote Switch Control [8]	Geo-fencing technology	<ul style="list-style-type: none"> <li>GPS technology</li> <li>Android API</li> </ul>	System may give unreliable data due to lack of performance. Required to maintain a proper network connection.
Automatic Work-Hours Recorder for Medical Staff (Staff Hours): Mobile App Development [9]	Geo fence technology	<ul style="list-style-type: none"> <li>GPS technology</li> <li>Android OS</li> </ul>	Can't obtain accurate details of staff. Not suitable for smaller work areas.
Geofencing post-disaster scenario using android app [10]	Geo fence technology	<ul style="list-style-type: none"> <li>GPS technology</li> <li>Web Server</li> <li>Android System</li> </ul>	Users have limited resources to access to the system. Hard to maintain the database with real-time data. (it may vary with the time)

### **Proposed system**

To overcome limitations in existing systems, geo-fence-based ATM detail protecting system was proposed. This system will develop as an android application with GPS technology. It obtains the location of every user and it will use as the authentication details to the ATM system. System will create geo fence points near every ATM machine with a certain radius. Whenever user want to do transactions with the ATM, they can confirm their location using the android app, it will check whether the user is inside the geo fence point and if so, it will give access to the system, otherwise it will block the users access.

### **Objective**

With the aim of developing the software, our project has identified following objectives.

- Provide users much more efficient and secure ATM system compare to existing ones.
- Provide users assured security to their money and private details.
- Use user location details as a substitution for the existing security mechanism. (PIN code)

This will help to implement a system which can help to change the world in a new different aspect. Research work will mainly help to reduce current fraud acts happening associated to existing banking system. It will also offer a great benefit to solve the national security issues.

### **Features**

- Give access to the user based on their current location using geo fence points.

- Provide fast access to the system.
- Provide better accuracy reliability.
- Provide much accurate location tracking process.

### **Requirements**

#### **Functional Requirements**

- System should be able to maintain the database.
- System should be able to record customers details in the registration process.
- System should provide administration the authority to control every procedure happening inside the system.
- System should provide customers' ability to take part in regular banking activities after the authentication procedure.

#### **Non-Functional Requirements**

- System should be able to give access to users much faster than existing systems.
- The system should be able to load existing data quickly.
- System should store details of every user in a secured way and should prevent any unauthorized access.
- System should contain a user-friendly interface and need to be very easy to use and adopt to it.
- System should be able to provide a quick authentication process.

#### **Limitations**

- Environmental issues can be affected to reduce the accuracy of the system.



- Some people may find it hard than the usual pin-based method.
- Population coverage is another limitation in these systems. When we deploy a novel solution, we cannot guarantee to cover target population.
- Disabled people will find it hard to use these kinds of systems.

### Conclusion

The growth in the frauds acts related to ATM systems have made a huge impact to the society. ATM transactions often use PIN's for the identification of users. This existing security mechanism failed to overcome these threats. Novel system based on geo fence technology has been introduced to overcome above problems related to ATM system. In this system it will implement as an android app with GPS technology. It uses user location as authentication details and users need to be inside the geo fence points to get access to the system. Objective behind implementing this system is to reduce errors in ordinary pin-based authentication system and to improve security mechanism related to ATM systems in an effective way.

### References

- [1] O. Selina and J. Oruh, "Enhanced atm security system using biometrics," *Int. J. Comput. Sci. Issues*, vol. 9, no. 5, pp. 352–357, 2012.
- [2] M. Abdolahi, M. Mohamadi, and M. Jafari, "Multimodal biometric system fusion using fingerprint and iris with fuzzy logic," *Int. J. Soft Comput. Eng.*, vol. 2, no. 6, pp. 504–510, 2013.
- [3] M. A. Kassem, N. E. Mekky, and R. M. EL-Awady, "An enhanced ATM security system using multimodal biometric strategy," *Int. J. Electr. Comput. Sci.*, vol. 14, no. 4, pp. 9–16, 2014.
- [4] B. Himanshi, T. Himani, and G. Harshi, "Fusion Of Iris And Fingerprint Biometric For Recognition," *Int. J. Adv. Res. Sci. Eng.*, vol. 2, pp. 35–41, 2013.
- [5] M. O. Onyesolu and I. M. Ezeani, "ATM security using fingerprint biometric identifier: An investigative study," *Int. J. Adv. Comput. Sci. Appl.*, vol. 3, no. 4, pp. 68–72, 2012.
- [6] K. B. Raja, "Fingerprint recognition using minutia score matching," *ArXiv Prepr. ArXiv10014186*, 2010.
- [7] R. G. Jimoh and A. N. Babatunde, "Enhanced automated teller machine using shortmessage service authentication verification," *Afr. J. Comput. ICT*, vol. 7, no. 1, pp. 115–120, 2014.
- [8] J. Wong, D. Sang, and C.-S. Peng, "An Android Geofencing App for Autonomous Remote Switch Control," *Int. J. Comput. Inf. Eng.*, vol. 11, no. 3, pp. 325–333, 2017.
- [9] B. S. E. Ting-Wei Chiang, S.-Y. Chen, Y.-C. Pan, and Y.-H. Lin, "Automatic Work-Hours Recorder for Medical Staff (Staff Hours): Mobile App Development."
- [10] D. Suwal, S. Manandhar, G. Dhakal, and S. Maharjnan, "Geofencing post-disaster scenario using android app," 2015.

## Introducing a LSTM based Flood Forecasting Model for the Nilwala river basin with a Mobile Application – a Review

RM Ranasinghe<sup>#</sup> and WMKS Ilmini

*Faculty of Computing, General Sir John Kotelawala Defence University  
Rathmalana, Sri Lanka*

<sup>#</sup>rashmimadhushani15@gmail.com

**Abstract**— Flooding is one of the most devastating natural disasters in the world. The impact of flooding is damage to property, Agriculture, Infrastructure of a country and destroy human life. Flood Forecasting models and proper awareness about floods, sufficient communication between the flood victims and the responsible authorities are important to safeguard the life of human and the infrastructure of a country. This paper contains review of different Machine Learning methods and Algorithms like Artificial Neural Networks (ANN), Support Vector Machine (SVM), Multilayer Perception (MLP), Convolution Neural Networks (CNN) and Long Short-Term Memory (LSTM) which are used to forecast floods. Long Short-Term Memory is one of the Recurrent Neural Network models to forecast Flood. According to the reviewed literature Long Short-Term Memory networks are better than ANN, MLP and SVM because Long Short-Term Memory models can learn long-term patterns better.

**Keywords**— Flood forecasting, LSTM, Mobile Application

### Introduction

Flooding is one of the most destructive natural disasters in the world. It affects the infrastructure of a country, agriculture, human life and the socioeconomic system. Flood is a result of natural and different human activities. Because of the high rainfall in the river and coastal areas water level of rivers are increasing. As a result, floods occur. Flooding becomes worse because of

climatic changes and exclusive urbanization. Pacific Region and Asia have considered highly disaster-affected areas in the world as a result floods occur frequently.

Flood Forecasting can secure village and city dwellers life and minimize the damage due to flooding. Further flood prediction is a method to reduce only the damage because there is no proper method and mechanism to avoid floods satisfactorily. Creating the Machine Learning modules for flood prediction is based on historical information of flood events. Machine learning is a way to create a machine or a program can learn by themselves through experience. The datasets usually used are rainfall and water level of the river basin. The flow of building a machine learning model is data collection, analyse the data, build model, train the model and testing the model. Data sets are used to train the model, testing, verification and validation. Machine Learning prediction models provide cost-effective solutions and better performance. Flood prediction models can be used to reduce property damage, minimize the loss of human life.

In Sri Lanka flood is associated with two monsoons. According to the Ministry of Disaster Management (“Flooding in Sri Lanka 2018,” 2018) two monsoons are Southwest monsoon season (May-September) and Northeast monsoon (December-February). During the southwest monsoon season Southern and Sabaragamuwa provinces are affected and North and North-Central

provinces are affected during Northeast monsoons.

Nilwala River basin is identified as a major flood (Mawatha, 2011) affected area in Sri Lanka. Flood affects human life and damage infrastructure and agriculture in Sri Lanka. According to Lakmali and others, (Lakmali et al., 2017) Nilwala river started at Panilkanda near Deniyaya in Sri Lanka after traversing about 72km the river flows to Indian Ocean at Matara. The annual rainfall of the upper basin is 3000 mm and lower areas receive 1900mm. During March to June and August to December monthly rainfall is above 200 mm. In other months rainfall is 150mm.

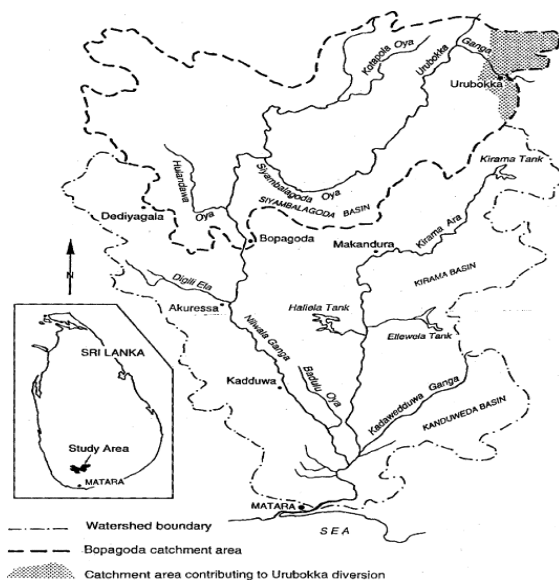

Figure 1: Catchment area of the Nilwala River (Mungai et al., 2004)

This study focuses on doing a review on flood forecasting and find the feasibility to forecast flood in Nilwala river.

In Sri Lanka, a successful Flood alert related mobile app has not yet been introduced to the public. Due to this reason, there is very limited communication between the people who very often get affected by floods and the responsible authorities. Thus, the relevant authorities find it difficult to provide the required assistance to the people in risky areas.

## Literature Review

There are various predictive techniques that are used to make predictions. They are statistics, data mining, machine learning, modelling and Artificial Intelligence. Further, there are many ways of flood forecasting models all over the world. Machine learning techniques are popular in the predictive analysis due to good performance with large datasets.

Machine Learning Forecasting models are created by using the historical data of floods including the real-time data of rain gauges and other sensing data. The main data sets used to predict are rainfall and the river water level. On the other hand, soil moisture, river inflow, peak flow, typhoon rainfall and daily flows are used. Further, the high resolution of weather radar provides more accurate and reliable datasets to create a prediction model. There is a different type of machine learning models to predict floods. They are Artificial Neural Networks (ANNs), Support Vector Machine (SVM), Multi Linear Perception (MLP), Back-Propagation Neural Network (BPNN) and Long Short-Term Memory (LSTM).

ANN is a popular and significant machine learning algorithm used to model complex floods with accurate approximations. ANN algorithms have been used to predict floods started since the 1990s (Wu and Chau, 2010). ANNs have been used in different flood prediction applications. Some of them are river flow, water quality, streamflow cast and river time series. According to Paul and Das's model, (Paul and Das, 2014) it predicts flood through data set of river water level, amount of rainfall, degree of permeable soil, degree of ground saturation etc. Flood prediction is a non-linear problem, so ANN approach is used to solve this non-linear problem in this model. Further, in this case Multi Linear Perception based Artificial Neural Network's Feed Forward (FF) and Back Propagation algorithm are used to

forecast flood. This model shows results (flood water level) before 24 hours. According to that this ANN model is more accurate than the statistical models. Also Thilakarathne and Premachandra created (Thilakarathne and Premachandra, 2017) flood prediction model using machine learning and Data Mining technologies. This is a hybrid model created for predicting floods in the North Central province in Sri Lanka with the use of ANN. It is a combination of two predictive models. 1<sup>st</sup> model uses time series modelling to predict future weather-related measurements. 2<sup>nd</sup> model predicts the probability of chance of flood in upcoming months. Bruen and all (Bruen and Yang, 2005) implemented real-time rain fall forecasting. Autoregressive-moving-average model (ARMA) and functional networks are used in this model. Functional networks are generalized version of Artificial Neural Networks (ANN).

Long Short-Term Memory models learn the main principles throughout the training process with the use of input, observed data. Further, those data are optimized to predict the water discharges properly and accurately.

Xuan-Hien Le and others (Le et al., 2019) done an Application of LSTM Neural Network for Flood Forecasting. They used rainfall, Flow rate data and daily discharge as inputs. This research is based on “Da River” basin in Vietnam and data set from before 1985 (1961 to 1984) of Hoa Binh Station. The efficiency for the three cases daily and two, three-day flowrate forecasting are 99%, 95% and 87%. According to them, there are two main methods for flow prediction.

The first approach is a mathematical model and the other one is Data-Driven method. Mathematical models are based on hydrology and hydraulics. This method needs more input data of rainfall forecasts and topography data which are not mostly available and easily accessible. The run time

of these models are taken a long time. Also, this model does not predict the increase of the downstream flow when the upstream flows sudden fluctuations data-driven methods (DDM) based on the statistical relationship between input and output data. Artificial Neural Networks are the most common data-driven model. In this model they used to evaluate forecast model using statistical methods NSE and RMSE. NES gives an idea about the ability to predict variance accounted by model. The RMSE is mostly used to evaluate how closely the predicted values match the observed values, based on the relative range of the data. This model related to open-source software libraries. There are different characteristics considered in this model they are input data type, input data quantity and the correlation of the measured data.

According to Frederik and others (Kratzert et al., 2018) introduced Rainfall-runoff modelling using LSTM networks. They used freely available 241 catchments from CAMELS dataset. Further, they used 4 out of the 18 hydrological units with their 241 catchments. The major findings of this model are LSTMs can predict runoff from weather related observations with accuracies comparable to the well-established SAC-SMA + Snow-17 model. Pre-trained knowledge can be transferred into different catchments, which might be a possible approach for reducing the data demand and regionalization applications, According to this model the main advantage of LSTM is the ability to learn long-term dependencies between the provided input and output of the network.

Multilayer Perception is an advanced representation of ANNs. In Indonesia flood occurs frequently and it causes many damages to human life and properties. To reduce this problem Widiarsari and others introduced (Widiarsari et al., 2017) Deep learning multilayer perception (MLP) for

flood forecasting. This system contains two parts. They are the control centre and the

remote site. Equipment in the field of data measurements means the remote site and web service is the control centre. MLP is used to predict rainfall time, sense data and water level of rivers. According to this project, MLP gives better prediction results in water elevation level on the downstream canal. In this model the smallest and the biggest error percentages are 0.82% and 46.48% respectively.

Support Vector Machine (SVM) is used in predicting floods. SVM flood forecasting modeling is a supervised learning method works with statistical learning theory and structural risk minimization rule. SVMs are used to classify both linear and nonlinear classifications. According to Opella and Hernandez's conceptual framework (Opella and Hernandez, 2019) the primary objective is the Geographical Information System (GIS) data in mapping the flood susceptible area in Wahig-Inabanga in the Philippines. It used two different machine learning techniques like Support Vector Machine and Convolutional Neural Network to product accurate maps for the flood. CNN is known in computer vision application with the advantage of learning visual features in this model. CNN is used for image processing tasks.

Above table shows the different machine learning modelling techniques used to forecast floods in different countries.

Singh and Borah (Singh and Borah, 2013) developed a prediction model with the Back Propagation Neural Network(BPNN)s to predict heavy rains and flood. Proposed model can predict seasonal rainfall amounts for next 5 years. The data set include time period of 1871-2010 on a monthly time period. They trained and tested five neural networks separately and compared them with another existing model

Table 1: Comparative Analysis of different ML Flood Forecasting models

Reference	Modelling Technique	Input Parameter	Prediction Type
(Paul and Das, 2014)	ANN (MLP)	River water level, amount of rainfall, degree of permeable soil, degree of ground saturation	Daily
(Thilakaratne and Premachandra, 2017)	ANN	Forecasted weather values and historical flood data	Monthly
(Le et al., 2019)	LSTM	Rainfall, Flow rate data and daily discharge	Daily, two, Three-day flowrate prediction
(Opella and Hernandez, 2019)	SVM and CNN	Rainfall data	Not mentioned
(Nayak, 2013)	SVM and ANN	Weather patterns	Hourly rainfall-runoff
(Widiasari et al., 2017)	Deep Learning and MLP	Rainfall time sense data and water level of rivers	Not Mentioned
(Kourgiolas et al., 2015)	Statistical analysis and ANN modelling	Five years hourly based data set	Leads 3h, 12h, and 19h flood prediction
(Singh and Borah, 2013)	BPNN	Rainfall data include time period of 1871-2010 on a monthly time period	Rainfall values for 5 years
(Lin et al., 2006)	SVM	Historical records of monthly river flow discharges	Long-term
<b>Proposed Model</b>	LSTM	Rainfall and water level	

The results show the BPNN models were fast and accurate with forecasting nonlinear floods. Due to nonlinear nature of Indian

summer monsoon rainfall prediction is more complex. Lie and others (Li et al., 2017) have conducted a project on ML algorithms and feature extraction for time-series. According to them SVM and RNN can be used to predict on a variety of time series data sets.

Flood prediction in short-term is a difficult task. But short time predictions are important for water resource management. Mosavi and Ozturk (Mosavi et al., 2018) have presented a paper on Flood prediction models. According to that Short-term flood, prediction can be done through single and hybrid methods.

Further, flood risk assessment contains four main processes. They are finding the geographical data of the specific location, analyses the variety of hazard and intensity, evaluate hazard, susceptibility and specify the area is beneficial to send an early alert with quick responses. Flood can be predicted hourly, Real- time, daily, weekly, monthly, seasonally and annually. According to the available literature, Machine learning can be used to predict both short-term and Long-term floods.

### Methodology

Requirements are gathered through questionnaires, observation and interviews from the people who are prone to floods, Department of Irrigation and Meteorology Department of Sri Lanka. Historical Weather data of Nilwala river of Sri Lanka have been collected from the department of Irrigation Sri Lanka. The main data sets collected are the water level of the river sub-basins and rain fall data. Panadugama, Pitabaddara and Bopagoda are sub-basins related to Nilwala river.

The main technology used to develop the model is Long Short-Term Memory. LSTM networks are a type of Recurrent Neural Network (RNN). This networks was introduced by the German researchers Schmidhuber and Hochreiter in

1997(Hochreiter and Schmidhuber, 1997). Long-term dependency problem can be avoided through

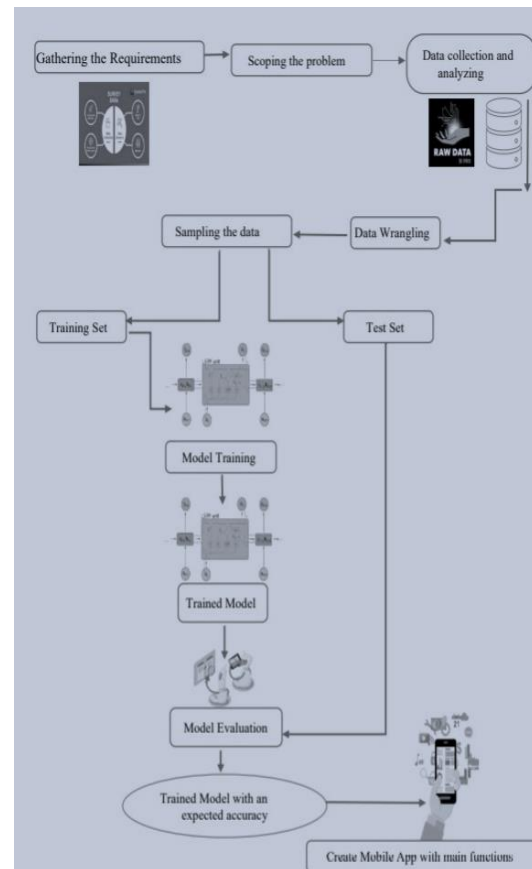

Figure 2: Methodology used to create the model

LSTM networks. LSTM networks have feedback connections. In this networks information stored in a cell. This cell allows read and writing also. This cell takes decisions about when to writes, reads and what to store through gates that open and close("A Beginner's Guide to LSTMs and Recurrent Neural Networks," n.d.). This cell contains three gates called input, output and forget. These gates are called "regulators".

Through a mobile application, flood alerts can be communicated to the people and relevant authorities. Further, the proposed mobile app included weather details, fund collections, Communication facilities given between flood-affected people and authorities like Disaster Management centres, Gramer sewaka etc.

## Discussion

Flooding can be identified as one of the most destructive natural disasters, that affects the infrastructure of a country, agriculture, damage to human life and the economic system. Flood prediction methods differ from Machine Learning algorithm, data sets and their application.

According to the reviewed literature, there are different machine learning methods that are used to predict flood. Most widely used Machine Learning method is Artificial Neural Network due to the accuracy of the results, fault tolerance and parallel processing with complicated flood function. Further the study proves that LSTM, MLP, SVM methods work better than Artificial Neural Networks. Furthermore, the reviewed literature shows hourly models make forecasts flood in advance usually between 3 hours to 48 hours. According to the existing models, the main flow of ML prediction are data collection, data preprocessing, Creating the model, training and testing the model.

Long Short-Term Memory has feedback connections which used to processing and making predictions related to Time series data, speech recognition and Handwriting recognition etc. Flood forecasting is a time series related problem.

Mainly Flood forecasting models are based on past data. As a result, data gathering is one of the main steps of this flood prediction process. Researchers can gather data from Government agencies like the Department of Meteorology and Department of Irrigation. For rainfall and water level are measured by rain gauges or remote sensing technologies like multi-sensor systems, radars and satellites.

This study focuses on flood forecasting using LSTM machine learning network for the Nilwala river basin in Sri Lanka. Nilwala basin is an area where flood is a frequent threat. To create a flood prediction model,

researchers can use two or more machine learning models, compare the results and give accurate flood forecasting for the users of this system. The study attempts to make aware of the authorities to safeguard the life of the resident in the Nilwala area. If this project becomes successful it could be improved to use in island-wide in future.

## Conclusion and Future Work

Flood forecasting is useful not only to the local and city dwellers but also different government institutions like National Disaster Relief Service centre, Department of Meteorology and Department of Irrigation etc. According to the literature reviewed Machine learning technologies can be used to flood. Long Short-Term Memory networks are better to forecast flood. Datasets used to predict are historical rainfall and water level of river basin etc. With the proposed flood forecasting model flood-prone people can be made aware of the flood through the mobile application.

## References

- A Beginner's Guide to LSTMs and Recurrent Neural Networks [WWW Document], n.d. . Pathmind. URL <http://pathmind.com/wiki/lstm> (accessed 7.24.20).
- Bruen, M., Yang, J., 2005. Functional networks in real-time flood forecasting—a novel application. *Advances in Water Resources* 28, 899–909. <https://doi.org/10.1016/j.advwatres.2005.03.01>
- Flooding in Sri Lanka 2018 [WWW Document], n.d. URL <https://www.jbarisk.com/flood-services/event-response/flooding-in-sri-lanka-2018/> (accessed 7.29.20).
- Hochreiter, S., Schmidhuber, J., 1997. Long Short-term Memory. *Neural computation* 9, 1735–80. <https://doi.org/10.1162/neco.1997.9.8.1735>
- Kourgialas, N.N., Dokou, Z., Karatzas, G.P., 2015. Statistical analysis and ANN modeling for predicting hydrological extremes under climate change scenarios: The example of a small Mediterranean agro-watershed. *Journal of*

- Environmental Management 154, 86–101. <https://doi.org/10.1016/j.jenvman.2015.02.034>
- Kratzert, F., Klotz, D., Brenner, C., Schulz, K., Herrnegger, M., 2018. Rainfall–runoff modelling using Long Short-Term Memory (LSTM) networks. *Hydrology and Earth System Sciences* 22, 6005–6022. <https://doi.org/10.5194/hess-22-6005-2018>
- Lakmali, U.W.U., Navarathne, C.M., Fowze, J.S.M., n.d. Development of Flood Hazard Map for the Selected Areas of Nilwala Downstream using HEC-RAS 7.
- Le, X.-H., Ho, H.V., Lee, G., Jung, S., 2019. Application of Long Short-Term Memory (LSTM) Neural Network for Flood Forecasting. *Water* 11, 1387. <https://doi.org/10.3390/w11071387>
- Li, L., Wu, Y., Ou, Y., Li, Q., Zhou, Y., Chen, D., 2017. Research on machine learning algorithms and feature extraction for time series, in: 2017 IEEE 28th Annual International Symposium on Personal, Indoor, and Mobile Radio Communications (PIMRC). Presented at the 2017 IEEE 28th Annual International Symposium on Personal, Indoor, and Mobile Radio Communications (PIMRC), pp. 1–5. <https://doi.org/10.1109/PIMRC.2017.8292668>
- Lin, J.-Y., Cheng, C.-T., Chau, K.-W., 2006. Using support vector machines for long-term discharge prediction. *Hydrological Sciences Journal* 51, 599–612. <https://doi.org/10.1623/hysj.51.4.599>
- Mawatha, W., n.d. SMALL ANICUT SYSTEMS IN NILWALA RIVER BASIN 43.
- Mosavi, A., Ozturk, P., Chau, K., 2018. Flood Prediction Using Machine Learning Models: Literature Review. *Water* 10, 1536. <https://doi.org/10.3390/w10111536>
- Mungai, D.N., Ong, C.K., Kiteme, B., Elkaduwa, W., Sakthivadivel, R., 2004. Lessons from two long-term hydrological studies in Kenya and Sri Lanka. *Agriculture, Ecosystems & Environment, Environmental Services and Land Use Change: Bridging the Gap between Policy and Research in Southeast Asia* 104, 135–143. <https://doi.org/10.1016/j.agee.2004.01.011>
- Nayak, M.A., 2013. Prediction of extreme rainfall event using weather pattern recognition and support vector machine classifier. *Theoretical and applied climatology* v. 114, 583–603. <https://doi.org/10.1007/s00704-013-0867-3>
- Opella, J.M.A., Hernandez, A.A., 2019. Developing a Flood Risk Assessment Using Support Vector Machine and Convolutional Neural Network: A Conceptual Framework, in: 2019 IEEE 15th International Colloquium on Signal Processing & Its Applications (CSPA). Presented at the 2019 IEEE 15th International Colloquium on Signal Processing & Its Applications (CSPA), IEEE, Penang, Malaysia, pp. 260–265. <https://doi.org/10.1109/CSPA.2019.8695980>
- Paul, A., Das, P., 2014. Flood Prediction Model using Artificial Neural Network. *International Journal of Computer Applications Technology and Research* 3, 473–478. <https://doi.org/10.7753/IJCATR0307.1016>
- Singh, P., Borah, B., 2013. Indian summer monsoon rainfall prediction using artificial neural network. *Stoch Environ Res Risk Assess* 27, 1585–1599. <https://doi.org/10.1007/s00477-013-0695-0>
- Thilakarathne, H., Premachandra, K., 2017. Predicting Floods in North Central Province of Sri Lanka using Machine Learning and Data Mining Methods. *Sri Lanka* 6.
- Widiasari, I.R., Nugroho, L.E., Widyawan, 2017. Deep learning multilayer perceptron (MLP) for flood prediction model using wireless sensor network based hydrology time series data mining, in: 2017 International Conference on Innovative and Creative Information Technology (ICITech). Presented at the 2017 International Conference on Innovative and Creative Information Technology (ICITech), IEEE, Salatiga, pp. 1–5. <https://doi.org/10.1109/INNOCIT.2017.8319150>
- Wu, C.L., Chau, K.W., 2010. Data-driven models for monthly streamflow time series prediction. *Engineering Applications of Artificial Intelligence* 23, 1350–1367. <https://doi.org/10.1016/j.engappai.2010.04.003>



### Author Biographies



RM Ranasinghe is a final year Software Engineering undergraduate of the Faculty of Computing, General Sir John

Kotelawala Defence University.

Kotelawala Defence University. Her research interests include Artificial Neural Networks, Deep Learning, Affective Computing and Data Mining.



WMKS Ilmini is a probationary lecturer of the Department of Computer Science, Faculty of Computing, General Sir John

## Feasibility Study of Hologram Gamification in Sri Lankan Higher Education Distance Learning

BMTN Rathnayake<sup>#</sup>, Indika de Silva and Bhanuka Senavirathne

Department of Information Technology,  
General Sir John Kotelawala Defence University of Sri Lanka

<sup>#</sup>rathnayakanawanjanathisaru@gmail.com

**Abstract:** When a global pandemic occurs, every industry faces the risk of unable to continue their usual processes and must go to business process continuity with instant change management. Considered the education industry also need an alternative solution to keep moving without failure. As experienced in such case distance learning is the best solution to conduct lessons. But the issue with normal distance learning is the learner's interactivity with lessons. To improve learners' interactivity with the help of technological advancement, higher education needs to deploy innovative teaching-learning methods including games, simulations, and holograms. Meanwhile, researches have proven that learning is not only a response to delivery but more than an active, constructive, cognitive, and social process by which the learner strategically manages the cognitive, physical, and social resources to build their knowledge. To enhance these aspects gamification can be a great deal, and which provides users with instant access to vast amounts of information without effort regardless of geographical or economic boundaries. Holographic technology might be another resource that could change the way to create and share knowledge. Gamification has been using for the learning and teaching process, but the hologram projection for learning is still new to the education industry but it has the potential to revolutionize aspects of teaching and learning experience. The sole purpose of this review study is to determine whether learners would perceive the gamification activities inbound with hologram technology

positively and will it help to enhance the interactivity in the teaching-learning process. Finally, increase the engagement of the distance learning process. To gain this outcome must study the feasibility of gamification in line with hologram technology regarding achieving distance learning objectives.

**Keywords:** Game-based learning, Simulations, Holographic projection, Distance Learning

### Introduction

Traditional learning and teaching is the base of any education system regardless of the level. And meantime due to some difficulties or inevitable reasons learners cannot come to the physical place, learn and focus on teaching and learning process. But considering geographical limitations, most of the learners cannot enrol or proceed with their expected foreign university. Also, when occurs a global pandemic even local university students have the difficulty of completing their academics. In this case, here it comes the concept of distance learning. People started to learn remotely, create learning materials, learning objectives and modules for distance learning. Nowadays there are plenty of ways to perform distance learning. But there are some issues to be considered as attracting learner's attention and make them want to learn more, which is still a difficult task to achieve. In that case, educators need to find new ways to achieve them and mitigate the risk of learner turn over due to unsatisfactory of the distance

learning technique. Responsible people for content creation of distance learning already using tactics like Augmented Reality (AR) which is quite successful. But in the long run, this same module with the same AR will be uninterested to the learners and the lecturers. So that there should be an alternative solution to proceed with this distance learning with some attractive, unique, changeable, and active technique. In this scenario, the famous gamification and hologram can use for the betterment of distance learning. Still, gamification and hologram technologies are two separate techniques. But can merge them techniques, build and expect a uniquely powerful platform for teaching and learning process. Upcoming topics describe, analyse, conclude and crucial factors to be considered when implementing such a system for Sri Lankan higher education.

### Effectiveness in General Distance Learning Methods

Distance learning has become a norm in the past few months even though it is been there for the past decade. The reality is, even though it was here for a long time, was never the mainstream learning method and helped to the traditional learning methods. Because of this, the general population never paid much attention to how effective distance learning can be as a standalone learning method. However, with the current pandemic situation question has been arising; does the distance learning methods as effective as traditional learning? The survey conducted among university undergraduates (sample of 60 persons) helps to determine the statistical situation regarding this matter. In this survey researches considered main two Distance Learning methods: Online Video Conferencing and Sharing Learning Material. So far, these two methods widely considered as best distance learning methods. 1<sup>st</sup> method is Using Online Video Conferencing

to interact with the student in real-time. For that this survey considered mainly two main platforms; Microsoft Teams and Zoom. 2<sup>nd</sup> method is sharing specially prepared study materials for self-study, for this method, the study also considered two widely used platforms; Google Services (Classroom, Drive) and University LMS.

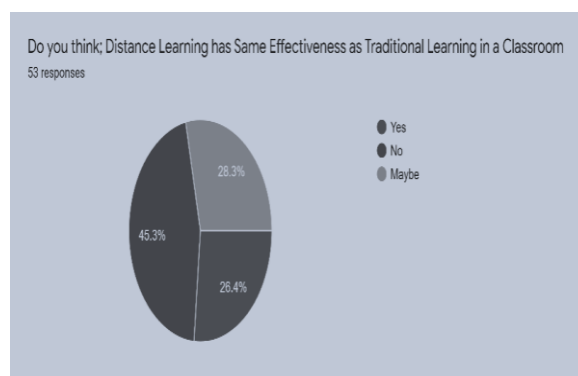

Figure 1. Pie chart of effectiveness regarding Traditional learning method and Distance learning method

The results reveal that the distance learning techniques do not yield the same result as traditional learning methods like Classroom Teaching. By looking at the below chart, the result shows that distance learning does not have the same effectiveness as Traditional Learning methods. Compared to traditional methods it has a considerably low rate. Further survey results reveal that many other factors affect distance learning (Figure 2).

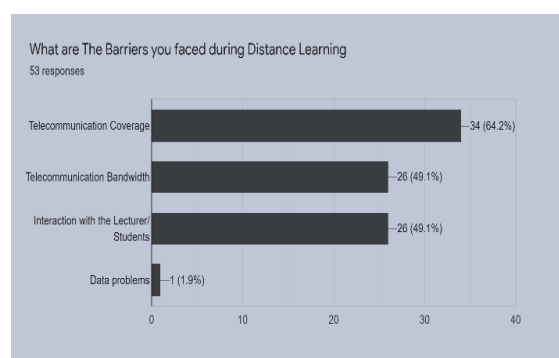

Figure 2. Major barriers for Distance Learning

Since Sri Lanka is still a maturing country technology-wise, the above chart proves the main barrier to Distance Learning is technology efficiency and literacy. According

to survey results, the study concludes that still, general Distance Learning Methods are not as effective as Traditional Learning Methods in Sri Lankan higher education sector. So that researchers suggest that to overcome this matter, use new interesting technology which is hologram along with gamification experience to improve the current situation of distance learning in Sri Lankan context and get more engagement in teaching and learning experience using distance learning.

### **Hologram Technology in Teaching and Learning Environment**

In this era for education purposes, can take advantages of holograms in different forms. For example, holograms now allow learners to be taught by a "virtual lecturer" who could be an indifferent geographical area. The relevant process goes beyond video conferencing in that the hologram lecturer appears to be in the classroom and can see and speak to the learners as if they were all in the same room. The system used by Edex, the largest supplier of Internet connections to the UK education market, at the BETT2000 educational technology show in London. Moreover, hologram technology can enhance the educational process by bringing famous characters to life again from the past, and they speak about themselves and/or explain something like an assistant lecturer. For an example in Seoul's Alive Gallery Project, holograms and 3-D animation technology bring the Mona Lisa and that hologram answering questions from students, like "Why don't you have any eyebrows?" and she is answering, "When I was alive, a woman who had big forehead was considered a beauty ... so most women had their eyebrows taken off for beauty".

Considering the history hologram was invented in 1947 by Dennis Gabor and won the Nobel Prize for Physics in 1971. His idea consists of a three-dimensional photograph executed with a laser beam through an object

so that a second ray is projected onto the reflection of light of the first ray which allows obtaining three-dimensional optical images. It can be explained that although this technique is not new, the illusory effect that it transmits has become very popular at that time. Then the holographic projection was advanced in time and relate with the visual improvement of the technique called 'Pepper's Ghost' which was developed in the mid-19th century. In present days, this technique is applied with improvements in the quality projection of the image and binocular vision, which makes it an animated hologram almost real to the original. The technique 'Pepper's Ghost' is based on the fact that the viewer is in the main room but the viewer cannot see that there is a compartment hidden under the stage (that is where the actor is located). On the top of that, there is a glass or reflecting surface that shows the floating and project "ghostly" figure of the actor, as a result of receiving the light that impacts on it and reflects on the surface located on the stage. The room, where the person or object to be projected is placed, should be perfectly black or dark to highlight luminous colours on the reflecting surface. So basically, Pepper Ghost is the official starting point of hologram projection.

Then the project of creating an interactive hologram for teaching science or other subjects was inspired by the research papers of Balogh "An interactive multi-user holographic environment"<sup>[22]</sup> and their collaborating research "A large scale interactive holographic display"<sup>[23]</sup> done by Agocs. Then both made a project in which they used different optical modules that sent light to a holographic display to show a hologram without the need for additional use of lenses. Meantime, Agocs<sup>[23]</sup> used diverse optical modules besides mirrors to obtain certain interactivity.

Other studies such as<sup>[24]</sup>, who developed a device composed of a field light visualiser

that allows human eyesight of binocular type to be able to see an image formed in 360 degrees. This is possible thanks to a high-speed projector, which transmits images to a mirror with holographic diffuser and an electronic circuit to decode digital video signals. As a result, a projection of the object is obtained which can be observed without the need to wear special lenses and which also avoids the restriction of seeing yourself only from a reference point. Then the study done by Ghuloum<sup>[25]</sup> tested that the effectiveness of holograms in education is the one performed by with 400 teachers. The results showed that educators considered this technique potentially effective in achieving meaningful learning.

Still, the researchers work on a way to use holograms for educational purposes, some researchers are based on analogic or transmission holograms which are in static plates and are not in motion. They deal with interactive holographic applications through posterior projection or mobile prisms whose objective is to create interactive contents of both commercial and institutional applications.

### **Games, Simulations and Gamification**

#### **A. Games**

In modern days, the interest in examining game use in higher education has increased. This includes educational games<sup>[11]</sup> digital game-based learning (DGBL), and applied games<sup>[12]</sup> Besides, learners sometimes include interactive exercises video games<sup>[13]</sup> or even expand to next-generation video games in the category of games. Considering web-based games, the technological platforms that implement digital game code include computers and consoles<sup>[14]</sup>. They can run on a web browser on mobile phones and other mobile gaming devices<sup>[15]</sup> like tablets. Without being affected by the very large game types, there is a lack of clear, shared definitions and terminology among learners

and lecturers, which has led to “terminological ambiguity”<sup>[16]</sup>. However, the need for shared terminology remains when discussing the different forms of games and simulations in higher education. Although academics and game developers may use various classifications to categorize games, the majority broadly agree on the seven major genres<sup>[17]</sup>; Action games - categorized as response based video games, Adventure games - the player solves problems to progress through levels within a virtual world, Fighting games which means these involve fighting with computer-controlled characters or characters controlled by other players, Role-playing games - players assume the roles of fictional characters, Simulations in which games modelled after natural or man-made systems or phenomena and players have to achieve pre-specified goals, Sports games - these are based on different kinds of sports and Strategy games which recreate historical scenes or fictional scenarios, in which players must devise an appropriate strategy to achieve the goal.

Recently, several studies investigated the effects of serious games on learning outcomes have been published. Researcher Sawyer refers to serious games as those games produced by the video game industry that have a substantial connection to the acquisition of knowledge<sup>[18]</sup>. Researcher Zyda expands Sawyer’s definition, adding that serious games are games whose primary purpose is not entertainment, enjoyment, or fun<sup>[19]</sup>. Serious games or say as educational games and virtual worlds developed for educational purposes shows that the potential of these technologies to motivate the player beyond leisure activities. In meantime there, there are considerable learning benefits offered by game-based learning (GBL), which can be defined as the use of game-based technology to deliver, support, and enhance teaching and learning

experience and evaluation the learner progression.

### B. Simulations

Simulations mean they create a scenario-based environment, where learners interact and apply previous knowledge with their practical skills to solve real-world problems, also allowing lecturers to reach their own goals. During this kind of scenario-based training, the player gains important skills such as teamwork, leadership, communication, decision making, task prioritizing and stress management [20]. The practical scenario may be carried out individually or within the team [21], leading to collaboration and knowledge sharing. With the explosion of such technology, increase the opportunities to interact with technological applications in an active and promote information access, share their ideas, knowledge sharing and content creation. In digital simulations which engage learners in the interactive and self-driven process of gain knowledge, is adopted in higher education. Some people define game-based e-learning as a digital approach which delivers, supports, and enhances teaching and learning experience, and evaluation the progress of the learner. Game-based e-learning is differentiated from GBL, discovering which tends to cover both computer and non-computer games. Delivering the related platforms are an essential fact for game designers when creating and distributing games and simulations, which can be a console, computer, video, online, mobile or 3D game. Designers have to consider and pay attention to game characteristics such as technical challenges, modules and techniques which are associated with the game design, the players involved in gaming, and the teaching modes; that can be single-player, multiplayer, collaborative or synchronous. The above-mentioned game classification is presented below (Figure 1). The main

difference between games and simulations is the games are tools which are artificial and pedagogical, they include conflict, rules, and predetermined goals, but simulations are dynamic tools, representing reality, claiming fidelity, accuracy, and validity.

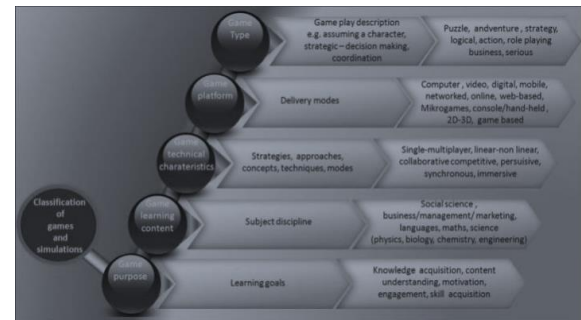

Figure 3. Classification of Games and Simulations

Source: Vlachopoulos and Makri *International Journal of Educational Technology in Higher Education* (2017) 14:22 Page 4 of 33

### Hologram Gamification and Expected Distance Learning Outcomes

Considering the gained knowledge there is a possibility to build a hologram gamification system for distance learning. So, the study proposes a Hologram Gamification system to battle shortcomings of general distance learning methods. By using Hologram gamification system, can expect some outcomes such as, Increase students attention span, Gamification experience increase the interest for learning which helps to improve the learning curve of each student, Increase the overall learning yield, holograms make a clearer image on the subject matter, helps to increase enthusiasm to try to become innovative and students tend to use logical approaches to solve problems and learn subjects. Which leads to improve the logical thinking and analytical skills of the student through gamification than normal distance learning method. Overall, there is a probability to increase more than 50% of students' knowledge, interest to learn the relevant subject.

Considering lecturer side this hologram gamification helps them to increase their

knowledge technology-wise and make their lives easier than traditional teaching-learning or distance learning using normal technology like video conferencing.

So, the overall outcome using hologram gamification system happens to be positive and it is promising to increase engagement of teaching and learning experience in distance learning,

### **Implementation Challenges and Limitations**

Although the concept of gamification has been around for years, the model of gamification techniques for teaching and learning process is relatively new. There are limitations involved in the gamification process that must be addressed and continuously evaluated through time to understand the full benefits of gamification.

To track the correct data to the teaching and learning process needed extensive training and pilot experiments must be conducted to stop confusing problems that could occur to the effectiveness of the virtual game. Both lecturers and game developers must be given the necessary time to learn the techniques of the games to be sure it is understandable and attractive to both audiences.

In addition to that, the design of the gaming system must provide meaning to the user/learner of the game. Without proper meaning, the learner and lecturer may lose their interest in the game quickly and become frustrated or lazy with their actions. If the sole purpose is not meaningful, unattractive to the user, the user/learner have a great chance of misunderstanding the ultimate goal of education-based gaming in the first place. By not meeting the expected outcome could lead to the user to stop playing the game. Which may cause a great disadvantage for the first place and give a bad image to the game developers who involved in the project. This affects negatively to the game developers and when

rescheduling and operate the project again with the same institute. To mitigate this risk factor game developers must keep a well-targeted audience and procedures in mind when designing game processes.

Hologram and virtual games can be so expensive to implement, especially the game requires high tech, high graphic resolution. For a considerably small institution might not be so ready to fund for such project and available to implement necessary components. Also, can be difficult to offer high tech pieces of equipment for a vast audience of higher education institutions. This fact can put high education institute in a difficult position. In the meantime, they may lose a competitive advantage over another institute in the higher education marketplace if a competitor institute can implement this kind of project without any problem. Considering game developers aspect just because of the high cost for developing, implement and maintain such game they will be unable to sell their game or can see the reduction of their revenue due to this high-tech game.

Also, the security monitoring, implementation and training costs can be high considering normal game-based e-learning system. Lack of knowledge in technology among lecturers and learners will be effective for user training and make things difficult.

Technological issues could arise during the implementation and maintenance, which must be quickly fixed if occurred when playing in real-time. Otherwise, the game will be rejected by the users. Also, hardware and operating systems must be upgraded before the gaming system launch, otherwise, most of the parts in the gaming system will not function well or stop functioning due to unmatching system components. This also provides a huge expense for an institution.

Gamification can also, costly to build and take a considerable amount of time. The concept design, initial production, editing, trial and publishing/implementation processes take much more energy and time to produce an effective product. Another problem is the user/learner spends more time learning the concepts and rules of the game than playing the game itself. If game developers are not fully dedicated to the gamification proposal and make it easier to understand to the user, it might not be worthy for even trying to build a one.

If the gaming strategies are built using separate teams, it may be difficult to monitor the individual performance of selected participants in user testing period. When the game developers designed the game, they must consider getting teams with more collaborative in terms of developing. Also, even if it is very difficult must have an idea about learners or educators background, lifestyles, personalities, and cultural values. If not, there is a risk of clash over their ability to complete the game successfully.

Considering hologram technology as a single entity that also has some disadvantages. Number one problem is the cost., then, hologram needs to be connected to a fast Internet, next-generation broadband Internet network like 5G with a minimum guaranteed constant speed of 20 megabits per second needed to implement. Finally, to use this technology perfectly, need a screening room with compatible lighting and video technology, which is costly when it comes to installing, as well as a display screen for viewing the holograms on also costly.

## Conclusion

The main two problems to implement such a system for a country like Sri Lanka; lack of technical knowledge, then that leads to hologram becoming an unreachable technology to build and the unbearable cost

for such high-tech system implementation. Even the 5G network is still in the implementing stage and the cost to install a hologram gamification system will be unbearable for most of the Sri Lankan higher education institutes. According to the analysis and found factors, can conclude that holographic gamification experience is still far to reach for a country like Sri Lanka. But instead of adding hologram as an alternative can implement adaptive gamification to the higher education stream in Sri Lanka. That will help to build the Sri Lankan Game development community and increase the quality of Sri Lankan higher education sector.

## References

- [1] "Playing with Holograms and the Gamification of Philosophy" [Online]. Available: <https://transitionconsciousness.wordpress.com/2014/02/17/playing-with-holograms/> [Accessed: 05-May-2019].
- [2] Dimitrios Vlachopoulos, Agoritsa Makri, "The effect of games and simulations on higher education: a systematic literature review", *International Journal of Educational Technology in Higher Education* 14:22, 2017
- [3] Lara Orcos, Cristina Jordán, Alberto Magreñán, "3D Visualization through the Hologram for the Learning of Area and Volume Concepts", Article
- [4] Michael Hitchens, Rowan Tulloch, "A gamification design for the classroom", *Interactive Technology and Smart Education*, Vol. 15 No. 1, pp. 28-45, 2018
- [5] L. Orcos, Á.A. Magreñán, "The hologram as a teaching medium for the acquisition of STEM contents", *Int. J. Learning Technology*, Vol. 13, No. 2, 2018
- [6] Husain Ghuloum, "3D Hologram Technology in Learning Environment", *Proceedings of Informing Science & IT Education Conference (InSITE)*, 2010
- [7] Hyangsook Lee, "3D Holographic Technology and its Educational Potential", Volume 57, Number 4 *TechTrends*, July/August 2013



- [8] Ahmed Elmorshidy, "Holographic Projection Technology: The World is Changing", *Journal of Telecommunications*, Volume 2, Issue 2, May 2010
- [9] Kibum Kim, John Bolton, Audrey Girouard, Jeremy Cooperstock and Roel Vertegaal, "TeleHuman: Effects of 3D Perspective on Gaze and Pose Estimation with a Life-size Cylindrical Telepresence Pod"
- Mehmet Kesima, Yasin Ozarslan, "Augmented reality in education: current technologies and the potential for education"
- Çankaya, S., & Karamete, A., "The effects of educational computer games on students' attitudes towards mathematics course and educational computer games". *Procedia-Social and Behavioral Sciences*, 1(1), 145–149.
- Van Roessel, L., & van Mastrigt-Ide J., "Collaboration and team composition in applied game creation processes", *DiGRA '11*, proceedings of the 2011 DiGRA international conference, think design play, 114, (2011).
- Biddiss, E., & Irwin, J., "Active video games to promote physical activity in children and youth", *Archives of Pediatrics and Adolescent Medicine*, 164, 664–672, (2010).
- Salen, K., & Zimmerman, E., "Rules of Play: Game design fundamentals", Cambridge, MA, USA: MIT Press, (2010).
- Willoughby, T., "A short-term longitudinal study of internet and computer game use by adolescent boys and girls: Prevalence, frequency of use, and psychosocial predictors", *Developmental Psychology*, 44(1), 195–204, (2010).
- Klabbers, J. H. G., "Terminological ambiguity game and simulation. *Simulation & Gaming*", 40(4), 446–463, (2009).
- Gros, B., "Digital games in education: The Design of Games-Based Learning Environments", *Journal of Research on Technology in Education*, 40(1), 23–39, (2007)
- Sawyer, B., "Serious games: Improving public policy through game-based learning and simulation", USA: Woodrow Wilson International Center for Scholars, (2002).
- Zyda, M., "From visual simulation to virtual reality to games", *Computer*, 38(9), 25–32, (2005).
- Flanagan, B., Nestel, D., & Joseph, M, "Making patient safety the focus: Crisis resource management in the undergraduate curriculum", *Medical Education*, 38(1), 56–66, (2004).
- Robertson, B., Schumacher, L., Gosman, G., Kanfer, R., Kelley, M., & DeVita, M, "Simulation-based crisis team training for multidisciplinary obstetric providers", *Simulation in Healthcare*, 4(2), 77–83. doi:10.1097/SIH.0b013e3181917cd, (2009).
- Balogh, T., Dobranyi, Z., Forgacs, T., Molnar, A., Szlobod, A.L., Gobbetti, E., Marton, F., Bettio, F., Pintore, G., Zanetti, G., Bouvier, E. and Klein, R, "An interactive multi-user holographic environment", in *SIGGRAPH '06: ACM SIGGRAPH 2006 Emerging Technologies*, ACM Press, New York, NY, USA, p.18. (2006)
- Agocs, T., Balogh, T., Forgacs, T., Bettio, F., Gobbetti, E., Zanetti, G. and Bouvier, E, "A large scale interactive holographic display", in *VR '06: Proceedings of the IEEE Virtual Reality Conference (VR 2006)*, IEEE Computer Society, Washington, DC, USA, p.57, (2006)
- Jones, A., MacDowall, I., Yamada, H., Bolas, M. and Debevec, P, "Rendering for an interactive 360° light field display", *ACM Transactions on Graphics (TOG)*, Vol. 26, No. 3, pp.40–50 (2007)
- Ghuloum, H, "'3D hologram technology in the learning environment", *Informing Science & IT Education Conference*, pp.693–704, (2010)

### Acknowledgement

This research was greatly assisted by Academic staff and we thank our colleagues from the General Sir John of Sri Lanka, who provided support to the research.

## Web-Based Application For Mothers & Midwives

DGBC Wijayawickrama#, SCM De Sirisuriya, N Wedasinghe

*General Sir John Kotelawala Defence University, Ratmalana, Sri Lanka*

#bumalshi96@gmail.com

**Abstract:** Web-based applications have become the most common platforms for developing information and services via the internet. Because of the evolution of these web-based applications, people have able to communicate with different kinds of applications. So, this project has been decided to help parents, especially for mother and midwives through a web-based application. When parents have to take their children to meet midwives and doctors up to two-three years since their origin, they have to conduct a book to record the details of their children. This is a very critical situation for carrying their children and keeping a record book. The worst thing is they cannot keep their child with another person also to attend the clinic due to the grasping issues. Parents also may not remind all the instructions given by the midwife and has to repeat again and again about previous reports and the baby's condition at the next clinic date. When midwife wants to visit mom's places, they have to face lots of difficulties like forget to bring documents, wouldn't find the location, suitable route to visit the place etc. So, this is the research to optimize the relationship between the parents and midwives through a web-based application with interconnecting mothers and midwives. The analysis part has been done via an interview with using parents and midwives. To enhance the relationship between mother and midwives, this system is tried to set all of the factors into a web-based software solution with surveying all the mixed methods in Sri Lanka.

**Keywords:** Motherhood, mother - midwife relationship, mother and baby

### Introduction

The most precious relationship is the mother and child in the world. All other humans have to help to enhance this amazing relationship since the origin of the child. The birth of a child is wonderful,

it is a life-changing time for a mother and her whole family. There are fresh hopes and new dreams since the time of new beginnings, and it changes all the things. Birth of a child shapes parents lives and families forever.

Today, almost everyone conducts their relationships over the internet and technology. Most of the scenarios are also running as online applications as web-based applications. If the relationship between mother and midwives comes into such kind of web-based application, it will impact to fulfill all the requirements of the mother since the pregnancy period and until to child's growth. When there won't good protection to mother and baby, most of the injuries can happen.

Normally Sri Lanka's antenatal care is consisting of two delivery services as Domiciliary care and Clinic care. Domiciliary care involved by PHM and clinic provided by medical officer including midwives. Antenatal care includes a package of interventions to ensure the health and wellbeing of the mother and newborn baby. This system has focused on the wellbeing of the baby since their origin.

The overall aim is to overcome the difficulties of mothers and midwives by converting manual file records into a web-based software solution. As objectives, this project is used to automate the baby's clinic record book. The midwife can fill the baby's details without using manual records. Parents have accessibility to view the child's growth, record book details, special notices and notifications and receive messages about reminders. The system is generated reports to observe special needs babies and filter nearest addresses to visit baby's places for midwives.

Even though there are apps for babies, those are not fully automated with these records and especially for mother and midwife both parties. Unlike other applications, this system is used to save the time of mother and midwife. Especially it hopes to enhance the relationship between mother and midwife.

It is accepted that a good start at the beginning of life makes a child be an efficient person of the society, hence the first five years is a crucial period of child's growth and development (Fayaz and Goonawardane, 2017). It has associated with the mother's adequate knowledge about the child's development. So, midwives must involve with mothers to help their childcare.

Normally, every woman must develop a personalized care plan with the help of a midwife and other professionals. When there is unbiased information, they can build their own plan it helps to care about their children. When it happens through some kind of own digital tool, it gives the capability to access their own information and keep records about their children. So, without any difficulties, they can be accessed to their own account and having reminders etc.

This project has designed after identifying the difficulties of parents and midwives in Sri Lanka. Because they have faced very conflict situations when caring a child. Sri Lanka

made special efforts to extend health services, including critical elements of maternal health care (Levine, 2007). After studying these kinds of efforts, the system is used to overcome these issues as much as possible.

Normally all Sri Lankans are in a very tight schedule with the globalization even though that they must take care of their babies very well. This effort directly goes to mothers who are involving with the baby every day.

According to the Table 1-1 more than 90% of mothers had formal health information (n=380, 93.6%) while PHM home visit played a vital role in providing this knowledge (65%, n=261). Antenatal clinic visits and MOH provision of knowledge were 10.2% and 6.9%, respectively. Only 2.7% (n=12) of them obtained information regarding developmental milestones from the CHDR. Nearly 80% of mothers obtained health information (n=326, 81.5%) through informal sources such as parents (72.4%), peers (9.8%) and media (6.1%) (Fayaz and Goonawardane, 2017)

Table 4. Source of information available for mothers on developmental milestones

Background characteristic	Antenatal care provider						Total	Percent of women receiving antenatal care from selected provider	Number of women married
	Obstetrician	Medical officer of health (MOH)	Other health worker	Public health nurse	Other	No ANC			
<b>Mother's age at birth</b>									
<20	57.0	30.3	6.9	4.9	0.3	0.5	100.0	99.2	349
20-34	85.3	25.5	3.9	2.9	0.3	0.0	100.0	99.8	5,735
35-45								1.0	100.0
<b>Birth order</b>									
1	89.2	22.2	4.8	2.7	0.4	0.9	100.0	99.6	2,912
2-5	50.0	22.0	2.5	2.9	0.4	0.5	100.0	99.3	4,125
6+	(37.2)	(35.2)	(21.5)	(0.9)	(0.0)	(6.9)	(100.0)	(99.2)	29
<b>Residence</b>									
Rural	85.5	23.0	4.5	2.0	0.3	0.2	100.0	99.5	5,124
Urban	51.1	21.7	3.4	0.2	2.2	2.2	100.0	99.0	2,098
<b>District</b>									
Colombo	80.6	14.6	4.5	2.2	0.0	0.6	100.0	99.4	931
Campanha	89.1	23.9	4.8	1.6	0.2	1.8	100.0	99.0	690
Puttalam	84.2	28.9	4.0	3.1	0.1	0.0	100.0	99.4	443
Kandy	89.0	32.7	5.9	4.1	0.0	0.0	100.0	99.0	492
Katle	89.2	26.7	2.7	4.5	0.3	1.9	100.0	99.1	332
North Western	81.3	14.1	1.7	1.9	0.3	0.7	100.0	99.1	380
Madaya	83.4	18.7	4.4	2.3	0.0	0.0	100.0	99.7	284
Jaffna	39.4	37.7	12.3	6.3	0.0	2.2	100.0	97.5	170
North Eastern	82.1	15.7	4.4	3.0	0.0	1.4	100.0	99.7	235
Vavuniya	44.0	86.2	10.9	6.0	0.0	2.0	100.0	97.4	42
Middle Western	84.1	43.9	19.2	0.0	0.0	1.9	100.0	97.4	262
Batticaloa	44.4	44.3	6.4	4.0	0.0	0.0	100.0	100.0	217
Ampara	88.0	49.3	11.0	0.0	0.0	0.0	100.0	99.0	168
Kurunegala	73.4	16.0	3.1	3.9	0.0	0.5	100.0	99.0	613
Puttalam	68.6	23.9	0.0	0.8	0.0	0.7	100.0	99.3	282
Arurudhapura	21.5	75.0	2.6	0.0	0.0	0.3	100.0	99.7	389
Polonnaruwa	89.0	47.6	2.0	0.4	0.0	0.0	100.0	99.0	297
Baddegama	42.2	61.6	2.0	0.4	0.0	1.1	100.0	98.0	274
Moragatala	46.2	27.0	0.7	24.1	0.0	1.5	100.0	99.2	508
Pallegoda	74.7	41.6	0.0	0.3	0.0	0.0	100.0	99.7	393
Kegalle	80.0	17.7	1.7	0.6	0.0	0.0	100.0	99.0	275
<b>Education</b>									
No education	44.0	36.2	11.0	2.3	0.0	3.7	100.0	99.3	51
Passed Grade 1-5	40.1	27.8	6.5	6.8	0.3	2.0	100.0	97.2	227
Passed Grade 6-10	61.3	27.8	6.9	4.8	0.2	0.8	100.0	99.0	3,124
Passed O.C.E.(A/L) or equivalent	75.5	18.1	2.6	2.1	0.3	0.7	100.0	99.0	1,706
Diploma and above	83.7	12.9	2.8	0.5	0.7	1.3	100.0	99.0	1,413
<b>Wealth quintile</b>									
Lowest	60.3	36.5	7.5	5.2	0.2	1.1	100.0	99.3	1,413
Second	69.0	30.3	5.8	2.5	0.2	0.6	100.0	99.2	1,437
Third	68.0	25.0	3.9	2.2	0.0	0.7	100.0	99.0	1,497
Fourth	70.2	21.0	4.4	2.7	0.2	0.6	100.0	99.2	1,224
Highest	81.3	0.8	1.9	4.4	0.0	0.0	100.0	99.7	1,284
<b>Total</b>	<b>63.4</b>	<b>23.7</b>	<b>4.7</b>	<b>3.0</b>	<b>0.3</b>	<b>0.9</b>	<b>100.0</b>	<b>98.8</b>	<b>7,136</b>

When researching such kind of aspects can clarify that every woman wants some kind of support from their midwife when caring a child. Especially in Sri Lanka young mothers' knowledge about child care is not good with

the busy lifestyle. They need some technical support for getting their work easily.

Nowadays the most common and flexible method is designing a web-based application to overcome their issues. There are several types of applications for supporting mothers.

Cumberlege had been proposed as a digital tool for improving choice and care about children. But the thing is these suggestions have not involved totally with midwives especially when they are going to visit their client's places.

South Warwickshire set an electronic notes system for maternity care. It is like a tablet computer which can be used by midwives to enter information. Normally, it has interconnected with the hospital.

Another one is M4ID project and this system has concerned about the pregnancy period only and only for mother, it has not concerned about the child.

Table 1-5. Antenatal Care

Sources of information	No.	%
<b>Formal health information<sup>1</sup> (N=381)</b>		
PHM Home visit	261	65.0
Antenatal clinic visit	42	10.2
Postnatal clinic visit	11	2.7
Antenatal classes	22	5.4
Medical officer of health	28	6.9
General practitioner	5	1.2
Child health development record	12	2.7
<b>Informal health information<sup>1</sup> (N=332)</b>		
Parents	236	72.4
In-laws	19	5.8
Peers	32	9.8
Neighbours	7	1.5
Media	22	6.1
Others	16	4.3

<sup>1</sup>Multiple responses

According to the Table 1-2 ninety-nine percent of ever-married women received antenatal care from a skilled healthcare provider via doctors, nurses and midwives for their most recent birth. Only one percent of ever-married women did not receive antenatal care for birth in the preceding five years. Of those who received antenatal care from a health provider, 65 percent received it from an obstetrician, 26 percent from a

medical officer of health (MOH), 5 percent from another doctor and 3 percent from a public health midwife(Health, 2005).

Even though midwife is concerning for babies, there are issues such as they cannot contact them when they needed due to the difficulty of finding contact details, the mother has to rewind all the details about the baby and midwife has to read the reports, see the record book, the midwife has to spend the whole day to visit baby's place it may be useless due to the unavailability.

As the first section, this paper is identified about the relationship between mothers and midwives and their importance. The literature review is used to identify previous projects in the second section. The third section is Methodology and describes the architecture of the project and Implementation has used to identify system interfaces as the fourth section. Discussion and Conclusion is the fifth section and has identified further improvements of the project

## Literature Review

### A. Relationship Between Mothers and Midwives

Childbearing is a period of psychological challenges that must be viewed in a social context. This study reports the maternal transition from the perspective of Iranian first-time mothers in the first year after childbirth. (Javadifar et al., 2016)

This is the research to optimize the relationship between the parents and midwives. According to the above-said statement after giving birth to a child, the mother's psychological situation is totally difficult to manage. At that moment everyone who is engaging with her like her husband, friends and not even her family, midwives also should help her. This project helps to enroll these midwives to interconnect with mothers and babies.

## B. Mothers

Today, mothers who are involving with their first maternity period, they haven't any experiences about this, most of the cases they are in busy lifestyle even their husband, and other family members. So, they may not get any exposures from their mothers about child caring.

"When a mother doesn't know anything about raising children and taking care of a newborn, how to change the baby's diaper, how to treat the baby when he is sick and how to give him medications, and when there are no experienced older parents around to tell her how to take care of these things and how to take care of her own stitches too, then the information provided by the midwife will be useful" (W1, 26 years old, first delivery) (Attarha et al., 2016a)

According to the Attarha, when mothers not knowing about childbirth and caring, both parties have to face huge conflict situations.

Based on the qualitative content analysis of Attarha there are four results can cause due to mental health promotion. They are Relieve stress and relaxation, mother-infant bonding, improved relationship with spouse and prevention of depression (Attarha et al., 2016a)

Mother's depression cause for caring for their children, it may either positive or negative due to the mentality of the mother. This project is helped to build the relationship from an automated system with the convenience of their duties.

According to the Dahlberg said that "Midwifery care is the best method of creating a positive experience of childbirth for mothers, and midwife's communication skills, knowledge, understanding and their presence are vital to this experience"(Dahlberg, Midwife and Aune, 2013)So, getting help from a midwife is essential for them. Based on the several

researchers, justify that women with a good midwife feel better about themselves, pregnancy and their baby.

It is the problem which has concerned with this project. So that the researcher has proposed an automated system due to, when building confidence in the midwife may benefit from continuous communication during the childbirth process. (Dahlberg, Midwife and Aune, 2013)

The midwife and mother relationship engaged with improving the quality of life not also to adopt health-promoting behaviours. Through that improve the knowledge of mothers about maternal and neonatal health care. (Whitehead, 2009) Whitehead state that the birth of an infant to a teenager represents a sudden role transition which has consequences not only for the teenager and her infant but the entire family system. This research shows the importance of a mother's health care. Due to different conditions, most of the mothers are suffered from anxiety and depression.

Teenage childbearing has serious consequences for teenage mothers, their children and the entire society but despite the negative consequences of teenage pregnancy and childbirth worldwide the rate is still high.(Vaishali Jadhav and Natasha Jadhav, 2016)

In the other hand, the possibility of relational continuity enables midwives to provide high-quality holistic care for mothers and helps to improve positive labour outcomes. Women should be encouraged to ask questions, to provide clear verbal information and to be as emotionally supported as possible.

## C. Maternity services

(Cumberlege) Cumberlege has found that most mothers want their midwife to be with them from the beginning, through pregnancy, birth and after the birth of the child. Time and again, mothers state that they

had hardly ever seen their professionals after their first meeting and had to repeat the same story because their notes had not been read and had been lost. Typically, this cannot be unacceptable, inefficient and needs to change. According to that report, this is too much variance in the quality of maternity services. Health professionals work under stress and too often do not work well together, particularly across the professional divide. That medical professionals and midwives spend far too much time for collect data and filling out paperwork, but the data which they have is often of poor quality and paper-based when it should be online, and in some areas of treatment, there is no evidence at all. When it comes to a system, it will be easy to keep evidence about child's and mother's information.

Antenatal care (ANC) has been recommended as a service that can reduce both maternal and newborn mortalities. (Katowa-Mukwato et al., 2019) This paper shows it more clearly by providing problems with antenatal care.

In Sri Lanka, health systems provide technical guidance to their respective provinces. The Public Health Midwife (PHMM) is the main grass-root level health care worker in Sri Lanka who promotes the health of communities. (Perera, Guruge and Gunawardena, 2015) According to the Renfrew (Renfrew et al., 2014) the degree and type of risk related to pregnancy, birth, postpartum, and the early weeks of life differ between countries and settings, the need to implement effective, sustainable, and affordable improvements in the quality of care is common to all.

#### D. Digital Tools

(Cumberlege) Cumberlege have proposed a digital tool for improving choice and care about children. Because NHS wants to make it easier for health professionals to gather and share data with others and with those for

whom they care. But the thing is these suggestions not have involved totally with midwives especially when they are going to visit their client's places.

South Warwickshire has set an electronic notes system for maternity care. It is like a tablet computer which can be used by midwives to enter information. Normally, it has interconnected with the hospital.

Baby Buddy App from the charity best beginning which guides women through pregnancy and for the first six months of their children live. In the other hand my birthplace, the pocket midwife is some kind of maternity apps.

According to the project of iDeliver, has executed a tool for improving maternal healthcare. Based on the M4ID support midwives with decision making, from the moment a pregnant woman arrives at the facility to give birth until the time she is discharged. Especially this system has concerned about the pregnancy period only and only for mother, it has not concerned about the child. Regional Office for Europe (WHO Regional Office for Europe, 2009) state that assessment tool is used for MoH, key stakeholders and partners, to carry out assessments of perinatal health care provided at facility level in a homogeneous and valid way, and ultimately to contribute to the identification of key areas of pregnancy, childbirth and newborn care that need to be improved.

This project is used to represent the way to increase the relationship between mother and midwives with an automated system.

### E. Comparison with prior studies

Table 6. Comparison of the proposed system and existing applications.

Features	New Proposed System	MCH App	Maatritva	Savika	Happy baby, Healthy mom	ZMD
Mother & Midwife both can access	✓	✗	✓	✓	✓	✓
Send message and advice	✓	✗	✗	✗	✗	✗
Reminders	✓	✗	✓	✗	✗	✗
Calculating statistical data	✓	✗	✗	✗	✗	✓
Find the shortest route	✓	✗	✗	✗	✗	✗
Chatbot	✓	✓	✗	✓	✗	✗
Tracking a child's growth	✓	✓	✗	✗	✗	✗
Help to avoid overweight during pregnancy	✗	✗	✗	✗	✓	✗
Document Management	✗	✗	✓	✓	✗	✓

Lots of researches and systems have been developed to secure and bring well-fare for parents and their new birth children and strengthen the relationship between midwives and parents since their pregnancy period. Especially for enhancing the relationship between parents and midwives.

Effective communication and emotional support of parturient women improve the outcome of childbirth. Reduction in Duration of labour, caesarean rate, use of anesthesia, and 5 minute Apgar Score less than 7 can achieve. (Attarha et al., 2016b)

When comparing this proposed system to those older studies, it must be pointed out that, those systems consist of only some instructions and few functionalities even there aren't any routing instructions.

### Methodology

During the requirement gathering and analysis phase data were collected from parents and midwives while the interview and they were not allowed to communicate to prevent cross-contamination. It included as face to face, unstructured interviews with participants by the researcher. Participant mothers were selected with the help of midwives. During interviews, questions were asked from mothers about their experiences with midwives and it has turned into the most specializing concept in this project, by asking their preferences about using an automated system with describing privileges. The researcher was asked about inconveniences when keeping records of babies and other conflict situations from participant midwives. For mothers as well as midwives is tended to persuade about the value of using an automated system.

At the beginning participants are informed of the purpose of the research and how it can affect their lives. This was the study instrument in this research. The questions were asked in a friendly manner and it helped to earn more details from them.

### A. Results

According to the mother's perspective, they expected from midwives to be with them since the pregnancy, birth and the after birth. Also, it happens without any restrictions because it is the duty of midwives. But at the next meeting with mother-baby and midwives and other professionals, they had been to repeat again and again about previous reports and baby's and mother's condition by finding previous reports and documents. Based on the midwife's perspective identified that inconveniences for

visiting places with carrying records and clarifying particular child. Totally it was time wasting and it should not be acceptable and not an efficient way as government workers. Also, it caused for disappointment by both parties.

After requirement gathering and analysis, system is used HTML for front-end and PHP as back-end development. It is designed interfaces based on the mother's and midwives' preferences. Especially concerning with HCI rules and standards hope to design user interfaces. The database is designed with few tables which can be untreatable to everyone at the design phase. The database management is done by the admin and design to manage midwives and parents accounts separately.

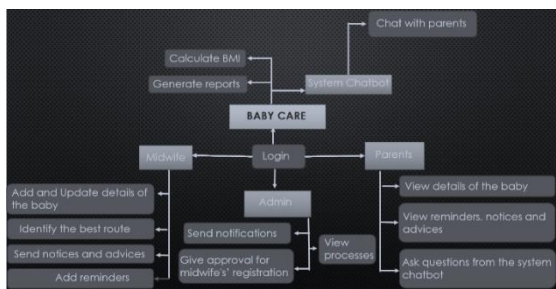

Figure 29. Baby Care Web Application

Through this project, the researcher implements the system mainly login access to both parties and adding details about them. The midwife can fill the relevant details of the baby in their account. Then, they don't want to keep manual records. If the mother is not aware of childcare scenario, they may not get worried furthermore, when adding every detail by the midwife. If there any conflict situation about the child such as underweight, overweight, it can be identified due to the records of their accounts and automatically generate reports base on the particular area of the midwife.

Mainly, the midwife can notice all the details and can assume the child's situation.

The midwife has to visit mother's places to collect information and give pieces of advice. Through this application, they can be aware of the best route to their places by identifying the shortest route to them. This project has implemented that functionality to get easier for midwives.

Also, mothers can get notices which are sent by a midwife about vaccinations, other medicines and reminders about the next clinic date to their mobile phone. Basically, a midwife can send notices individually or as a group according to their area.

### Implementation

This project involves identifying the requirements of midwives and mothers when communicating with children's welfare.

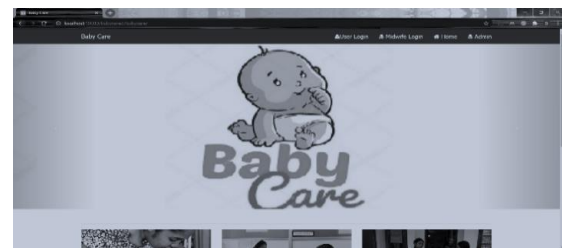

Figure 30. Home Page

Here is the home page which has accessibility to login to MOH, midwife and parents.

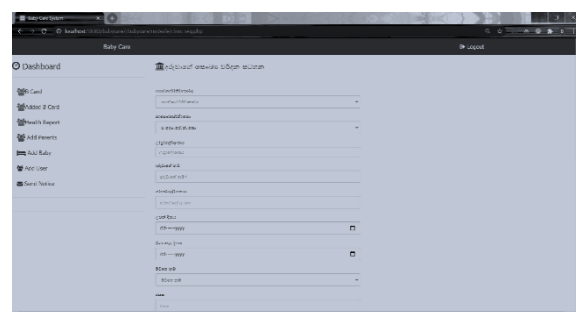

Figure 31. Detail Form

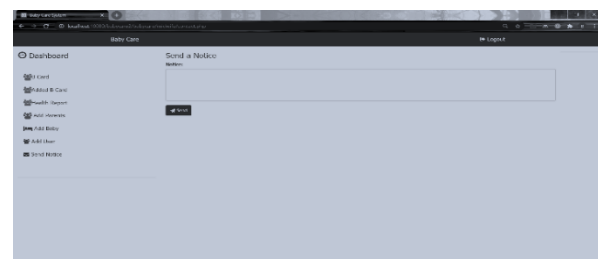

Figure 32. Sending notices by midwives to parents



A midwife can send notices to mothers who are in a particular area as a group or individually.

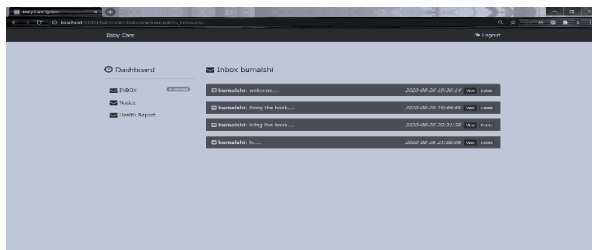

Figure 33. Parents can view messages

As like messages they can view all other notices and the baby's report.

### Discussion and Conclusion

The web-based applications can be developed into various forms according to day-to-day requisites. Among those requirements, providing system for mothers and midwives are one of the major functionalities that have to be executed. Through that can enhance the easiness of both parties and enhance the relationship between mother and midwife. This research helps to increase the efficiency and save the time of both parties. Also, it provides a solution for insufficiency.

As summarized in this paper represents system methods which can use to enhance the growth of the relationship between parents and midwife especially with considering children's well-being, because if the relationship of parents and midwife is high, the growth of children wouldn't stop furthermore. Especially this paper has concerned for mothers who can involve new technologies and provide a solution for their busy lifestyle. So, this paper hopes to implement the system to enhance the children's health assurance since their birth. This project is hoped to increase the lifestyle of midwives and mothers most steadily.

As limitations, this has not concerned about hospitals and other professionals and midwives have to keep their other manual records, because this has concerned only for

baby's records. This work can be further improved by studying, identifying and providing more functionalities to the system. It can be executed in hospitals over the country by combining them. Then every midwife can access their patients' information easily. If occur any sudden incidents to midwives, another person can handle that particular patient based on the web application.

### References

- Attarha, M. t al. (2016b) 'The Outcome of Midwife-Mother Relationship in Delivery Room: A Qualitative Content Analysis', *Health*, 08(04), pp. 336-343. doi: 10.4236/health.2016.84035.
- Cumberlege, B. J. (no date) Better births.
- Dahlberg, U., Midwife, E. and Aune, I. (2013) 'The woman's birth experience — The effect of interpersonal relationships and continuity of care', *Midwifery*. Elsevier, 29(4), pp. 407-415. doi: 10.1016/j.midw.2012.09.006.
- Fayaz, F. and \Goonawardane, S. (2017) 'Determinants of maternal knowledge on developmental milestones of children attending immunization clinics in the district of Colombo, Sri Lanka', *Journal of the College of Community Physicians of Sri Lanka*, 23(2), p. 71. doi: 10.4038/jccpsl.v23i2.8093.
- Health, M. (2005) 'Maternal health 9', pp. 111-125.
- Javadifar, N. et al. (2016) 'Journey to Motherhood in the First Year After Child Birth.', *Journal of family & reproductive health*, 10(3), pp. 146-153. Available at: <http://www.ncbi.nlm.nih.gov/pubmed/28101116> (Accessed: 23 October 2019).
- Katowa-Mukwato, P. et al. (2019) 'Evaluation of quality of antenatal care services in selected healthcare centres of Mumbwa and Lusaka districts of Zambia: Pregnant womens perspectives', *International Journal of Nursing and Midwifery*. Academic Journals, 11(5), pp. 32-40. doi: 10.5897/ijnm2019.0360.
- Levine, R. (2007) 'Saving mothers' lives in Sri Lanka', *Case studies in Global health: Millions saved*, pp. 41-48.

M4ID Digital Decision Making Support for Midwives – M4ID, July 8, 2016. Available at: <http://m4id.fi/testing-tools-to-improve-maternity-care-in-trans-mara/> (Accessed: 13 January 2020).

Perera, K. M. N., Guruge, G. N. D. and Gunawardena, N. S. (2015) 'Knowledge on Health Promotion among Public Health Midwives in a District in Sri Lanka', (January), pp. 1–10.

Renfrew, M. J. et al. (2014) 'Midwifery 1 Midwifery and quality care : findings from a new evidence- informed framework for maternal and newborn care', The Lancet. Elsevier Ltd, 384(9948), pp. 1129–1145. doi: 10.1016/S0140-6736(14)60789-3.

Vaishali Jadhav and Natasha Jadhav (2016) 'Using the jigsaw cooperative learning technique for nursing students: A review', International Journal of Nursing and Medical Investigation, 1(3), pp. 30–35. doi: 10.5897/IJNM2014.

What Is SDLC (Software Development Life Cycle) Phases Methodologies (no date). Available at: <https://www.softwaretestinghelp.com/software-development-life-cycle-sdlc/> (Accessed: 23 October 2019).

Whitehead, E. (2009) 'Understanding the association between teenage pregnancy and inter-generational factors: A comparative and analytical study', Midwifery, 25(2), pp. 147–154. doi: 10.1016/j.midw.2007.02.004.

WHO Regional Office for Europe (2009) 'Assessment tool for the quality of hospital care for mothers and newborn babies', (First Edition), pp. 1–138.

## Acknowledgment

The authors would like to acknowledge the General Sir John Kotelawala Defence University for the enormous guidance given.

## Author Biographies



Bumalshi Wijayawickrama is reading for Information Systems degree program at General Sir John Kotelawala Defence University and try to give solutions for real-world problems with the field of Information Systems.



Nirosha Wedasinghe graduated from London Metropolitan university-UK, and she has completed her Masters in CSU Australia. Currently, she is reading her PhD in the KDU Postgraduate Faculty. Her research interests are in the field of Digital accessibility and Management Information Systems. She has published, reviewed and supervised many research nationally and internationally.



S.C.M.de S Sirisuriya graduated from University of Sri Jayewardenapura, and she has completed her Masters of Computer Science degree from University of Colombo School of Computing. Recently, she competed her Master of Philosophy degree from University of Moratuwa. Currently, she is reading her PhD in the University of Sri Jayewardenapura. Her research interests are in the field of Artificial Neural Networks and Deep Learning.

## Smart Pest Recognition System for Sri Lankan Crop-Growing

LGC Theertha#, and WAAM Wanniarachchi

*Department of Information Technology, General Sir John Kotelawala Defence University*

# 34-it-026@kdu.ac.lk

**Abstract:** Srilanka is a developing country. Agriculture is main livelihood in sri lanka. Paddy cultivation is the major crop production among it. main problem in Paddy cultivation is pest defect. In Every month any pest defect may occur annually in Paddy cultivation. Therefore, sustainable cultivation concept is needed to compete with the modern world. Not only insect hazards, not only insects hazards but floods and rats also can damage the paddy field. There are many damages to paddy cultivation. Paddy farming uses a variety of chemical remedies to prevent insect damage and hazards. This results in loss of yield and a reduction in yield. The answer to this question is how to teach insect destruction by local chem methods. Details of unknown insects are readily available.

Another major problem for farmers is the lack of identification of insects as farming is concerned. Farmers have no idea about the threats or hazards happen to the crops by the insects currently it is a big issue facing the society. Due to the delay in getting the information about it. Because of the ignorance of the traditional medicines needed for these insects. For all these reasons, farmers are able to make choices easily.

This will help the farmer to identify the pest infestations that come to the farm and destroy the insects with the conventional methods of chemistry and other medicines needed to prevent them. Educates the farmer on how to make cam methods and how to use other medicines.

A demonstration system will be developed to address the reasons discussed above. Also, research is being conducted using the proposed system to evaluate and compare existing systems. It can provide the farmer with the most reliable, efficient, smart and convenient services

**Keywords:** Paddy cultivation, sustainable cultivation, insect hazards

### Introduction

Farming is one of the major processes that provide food for people. Farming happens throughout the whole world in different stages and different crops. When it comes to Sri Lanka paddy cultivation is the main crop. Among the cultivated paddy lands 64% of which is cultivated during the dry season and during the wet season 35% of paddy lands are cultivated. In Sri Lanka, nearly 879,000 farmer families are employed in rice cultivation. Among 20% of the country's population is engaged in paddy cultivation and 32% of the employment depends on paddy cultivation. Rice is the main meal among the whole people in Sri Lanka. Sri Lanka's agriculture mainly depends on the paddy cultivation. Rice production majorly depends on rainfall and the government supply essentials of water via irrigation tunnel or channels during the farming seasons. Also, some areas only use rainwater for the cultivation. There are two rice cultivation seasons in Sri Lanka which are known as "Maha" from October to March and "Yala" from April to September. Throughout Maha season, there is enough water to maintain the farming of all rice fields.

However, in the Yala season, there is not adequate water to cultivate all rice fields. Only half of the paddy land can be cultivated in the Yala season. Farmers, who are directly involved with paddy cultivation in Sri Lanka is facing a lot of problems. Several problems were revealed in paddy cultivation in Sri Lanka and most of them are still unsolved or doing manually. Those problems can be Agricultural, Biological, Transportation or Financial. When narrow down these things most people don't know what type of pest is good or bad for paddy type. Even though they selected proper pesticide insect, they don't know how to protect their cultivation from pest. There are several difficulties with using fertilizer and pesticides. Some people know the fertilizer dosage to use but their Paddy plants don't show the maximum growth rate. Though the cultivation is in 100% good condition people can't realize how much of rice harvest they will get. To find out solutions for these problems they will always have to run to agricultural specialists. But sometimes they won't get the most suitable answer because agricultural specialists are people and they make mistakes. When farmers are cultivating paddy, pesticide insects are common issues they face. These diseases can be insect/pest attacks, fertilizer deficiencies, and virus attacks or fungi disease. And when it comes to various paddy types, there will be different types of pesticide insect sets that are unique on paddy types. When farmers are continuously using pesticides to avoid these pesticides insects, pest vectors will adapt to pesticides. Therefore, farmers should have efficient, effective and reliable resources to eliminate these diseases. To eliminate diseases identifying the exact disease is the most important.

The Agro products are the important natural resources available to the people of Sri Lanka. Lots of people depend on land or Agro products to earn money. Sri Lanka is an

agricultural country which is mainly focused on rice cultivation. Paddy cultivation friendly insects play a major role in rice production. Paddy cultivation friendly insect supplies nutrition to the plants. Rice production rates have declined over the years due to improper insect breeding. Therefore, farmers must manage their paddy field properly to enhance and to get better productivity. Without proper knowledge of pesticide insects, farmers may not achieve maximum production. To avoid the above-mentioned circumstances the pesticide insect analysis function is introduced. Pesticide insect analysis function identifies insect type, insect texture of paddy in the paddy field by analyzing insect images. Finally, the elimination of pesticides and conventional methods of farming for them. They can also contact the Department of Agriculture as soon as possible.

The most common problem in Sri Lanka is finding out which insect pests are coming to the paddy field. This results in lesser growth of paddy plants. Growth analysis part of the system designed to maximize the farmer's productivity by identifying the growth problems of the rice plant in every growth stage. The system will provide farmers the ability to identify the growth rate of a rice plant in their paddy field by taking sample images. Which would otherwise have been performed by an agricultural expert? It's time-consuming and spends a lot of money because an expert may have to come much time and analyze the plant growth in different growth stages. By maximizing the farmer's work efficiency and production, the system will perform the farmer's requirements while remaining easy to understand and use.

Currently, there are no techniques to calculate or forecast rice harvest amount in Sri Lanka. So, it has been led to many problems. Farmers cannot get an idea of the extent of the harvest due to the pest in this

season. This will help the farmers to avoid pests and improve their productivity of the crop by educating the farmers on the use of traditional methods. When considering the current situation of the country, the society and daily life of farmers show that majority of the farmers in the society cannot fulfill their human needs. Because Farmers are unable to get their crops well. It is impossible to get the desired harvest. So, the farmers face a lot of problems for their needs and way of selling the harvest. Therefore, the farmers need to sell their harvest at any cost and need to abstain from the debts as soon as possible. Also, the farmers must sell the best amount of their production to the debtors and they need to debt again for their day to day life and usage of the family. Moreover, farmers will face a lack of money problems to buy fertilizers for next season. By knowing that harvest they can get debt according to their calculated harvest amount.

Nowadays, everyone has a mobile phone. Everywhere you go, we can see people use various types of mobile phones. Mobile phones have completely changed the human lifecycle. We can call, send text messages, read emails and play games by using this small device. Not only that mobile phones can be used to identify several types of agricultural issues because it is a convenient way to interact with users more easily. Most people have at least a simple, if not sophisticated, mobile phone. These devices are convenient to carry around and you can use them on the go as long as there is network coverage wherever you are.

Image processing is viewed as arbitrarily manipulating an image to achieve an aesthetic standard or to support a preferred reality. However, Image processing is more meaningfully described as the improvement of pictorial information for human perception. Rather than, enhance the pictorial information and extract image details helps to identify several pictorial

information which human can't see in their eyes. In this case, image processing is actively participated to do identification of pictorial information. Also, image processing can be used in a manner consistent with the scientific method so that others may reproduce and validate one's results. This includes recording and reporting processing actions and applying similar treatments to adequate control images. identify the problems of insects in paddy farming the research using image processing techniques(Azfar et al., 2018).

Data mining is a very important part that can analyze an enormous set of data and get hidden knowledge and useful data from large amounts of data. Data mining can be applied effectively to forecast or predict some valuable data via analyzing past data. The traditional ken method prediction part is used in data mining techniques to predict.

### **Literature Review**

Nowadays technology has made life easier and quicker. The modern world is developing many new things. One of the technologies is mobile phones. Mobile phones have vastly changed human life cycle. In Sri Lanka one person has more mobile phones. But people don't use new technologies to get better economic productivity.

Farming is the main occupation in Sri Lanka. Today most of the people involve with rice production and catch crops production. Every farmer has mobile phones, but they use that phone only for communication purposes. Sri Lanka does not have any android mobile application to analyze insect identification, know about traditional kem method. Either there are not any desktop applications to identification pesticide insects. Farmers cultivate do not know which fertilizer type to use in order to improve the harvest(Ravisankar et al., n.d.; Zhong et al., 2018).

The identification and classification of insects are major technical and economic importance in the agricultural Industry. There are several types of researchers to identify pest insects using image processing done inside Sri Lanka and abroad. Most of These researches have been done based on paddy fields and agricultural research institutes. Those researches are not made for the use of normal people. That means farmers cannot understand them and can't use it. In addition, to do these projects special equipment, laboratories, special condition, and field expertise are needed. Results of these researches will be used by agriculture professionals, and farmers always will have to run to them to get this knowledge(Jankielsohn, 2018).

There are many forms of work conducted locally with regards to pest insects utilizing computer systems. Most are performed in the areas of image recognition and analysis, data mining and artificial intelligence. But when it comes to usability, farmers can't use it. Those researches haven't deployed as a product to use for the people who are involved with farming. That means they are complex computer algorithms and farmers don't have the knowledge about how to work with them.

To order to combat some of the pest insects, new rice varieties are periodically published by agricultural research institutes. Therefore, if the research is old, it is not valid. Then we must invent new researches or update current systems. In Sri Lanka, there is no ongoing rice disease analysis system deployed yet. Therefore, old researches are not much valid when time passes.

When it comes to our work, it is focused on principles of machine intelligence, Photo recognition, and processing. And this system is a distributed application. The client is an Android mobile device. Most of the people in Sri Lanka, including farmers have mobile phones which can run Android application.

So, our system can easily be deployed into their mobile devices. There is no hard process to follow, farmers just have to upload their pest insect affected into the mobile application and then the client application will send images into the server and inside the server, images will be processed and the result will be sent to the client. Farmers will then quickly work out if the bug they are struggling with is a pest. The front end of the company does not include complicated items. Everyone will use the device without even learning how to program computers(Lou et al., 2013).

To analyze the growth of the pest insect, there are several types of research. But those researches are mainly based on one or two parameters such as height, insect size, insect's edge, color. In Sri Lanka, we don't have any system like this to identify pest problems. Not only in overseas counties, they did some work utilizing image manipulation methods, but these studies study on laboratory bases and they did it for a plant in unique conditions. In Sri Lanka, only work is performed by taking measurements manually and evaluating them for an insect community. Those researches are done for the purpose of identifying which insect is good for the specific area. Farmers don't have any involvement with those researches and all the things are do before paddy seeds come to farmers. In real-life circumstances, such researches were not added. They used such parameters just to calculate development in their laboratory conditions. Using more than two parameters to quantify different stages of development. The ultimate judgment on the growth of pest insects is focused on two criteria. That means the output result will be more accurate than other researches. In Sri Lanka, there is no system to identify paddy pest insects and tell how much use to traditional kem method. Farmers must do this by going to identify the insect and check the size and color which has given by

agriculture experts. Farmers must do this by going to insects in the plant and check the insects which have given by agriculture experts (Edirisinghe and Bambaradeniya, 2006; Oman, 1968; Yamamura et al., 2006).

pest insect prediction was already done by previous researchers, but they predict only for the current season. And some researchers have done it to count only the whole pest in a certain area. They did not predict the most suitable traditional kem method variety for the pest insects of the area, the most suitable irrigation system and future rice production per one acre. In this research, we forecast the most suitable traditional kem method variety for the pest type of the area, a pest for their individual paddy lands for up-coming paddy seasons for three years (Azfar et al., 2018).

Each country needs an efficient system of food production and distribution to provide the people with food security and to achieve economic development. Agriculture forms a significant part of the effort to produce food in a region. Several factors influence farm production from pre-harvest to post-harvest periods. This covers factors such as overproduction, underproduction, attacks on pests and diseases, and volatility in consumer prices. A more in depth research These problems indicated that the root cause was that farmers and other agricultural stakeholders were not providing the appropriate information at the right time when they most needed it. (Heeb et al., 2019) Both need published information such as crop varieties, fertilizers, correct soil types and complex real-time information such as current crop production rates, market prices, and outbreaks of pests and diseases. Smart Computing provides an creative way of producing situational information by presenting published awareness as actionable information, and by having users act on this information. In this, we expand our previous research by re-conceptualizing based on information flow in Global

Positioning Systems (GPS) to provide timely, actionable information through crop calendar functionality (Chandrasiri and Ekanayaka, n.d.; Ginige and Richards, 2013). We have implemented empowerment theory to establish empowerment-oriented farming processes to inspire farmers to produce crowd sensed information and integrate it to generate new situational awareness about outbreaks of pests and diseases. It provided a holistic model of information flow for the agricultural domain such as energy flow in biological environments enabling us to create a digital knowledge ecosystem for agribusiness. This device is now undergoing trials among thousands of farmers in Sri Lanka and India (Nishantha et al., 2016; Western Sydney University, Australia et al., 2019; Yang et al., 2005).

## Implementation

### A. Proposed system design Diagram

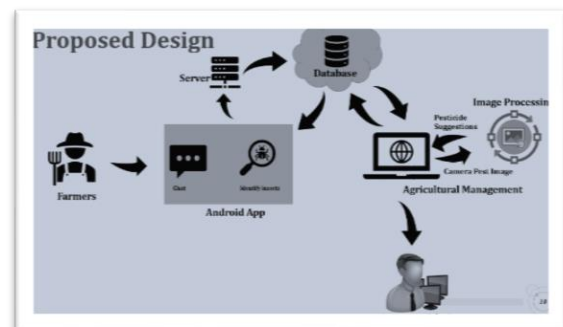

Figure 34 Proposed system design

Nowadays technology has made life easier and quicker. The modern world is developing many new things. One of the technologies is mobile phones. Mobile phones have vastly changed the human life cycle. In Sri Lanka, one person has more mobile phones. But people do not use new technologies to get better economic productivity.

Farmers face a lot of problems because of this problem, so using this technology, this project proposes an answer to this problem. Unidentified insects that come into cultivation are identified using image processing technology. Insect identification

is done using a data set from the insect. Identifies the insect and proposes the traditional medicine for the insect. Farmers can discuss issues with agriculture via SMS. The Department of Agriculture could record the details of each insect. Users can create their own account using the system One person in agriculture gives access to this system. He can remove and update the traditional insect-related additives. Implement most useful smarter, easier, and efficient System detect unknown insects and use traditional chem methods for insects.

My main intention has is to find a solution to the problems. Which is upcoming in the field of agriculture's order to succeed in my intention, I would collect reliable and quantitative data order to find a solution my proposed methods are

- Mobile App
- Realtime Database
- Web Development

In order to get information from this app to solve these upcoming problems, If the framer arises a problem related to pesticides.so he is eagle finding assistance to post control if the farmer has an out who is cannot be identified so then the system could be tracked. The pest using the motion tracking system.so they could obtain information from system motion tracking.



Figure 35 Home screen of the application



Figure 36 The correct insect appears

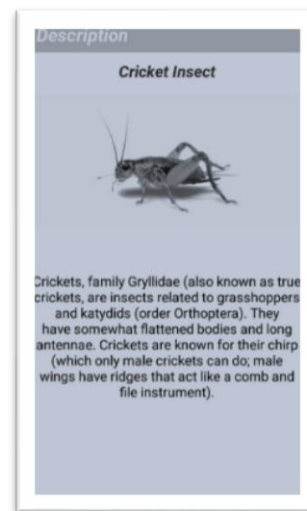

Figure 37 This interface shows the traditional kem methods of suitable of that pest and how to make them.

## Conclusion

The purpose of this research project is to provide efficient and effective service to farmers and agriculture-related people. Before we start this research project the major problem which farmers having was there was not an automated system that can be used by themselves. major problematic parts such as using many pesticides without knowing the exact limit to use and not knowing the exact pest. could not identify the cultivation is in proper growth and unable to predict next season's harvest. Came up with



a solution to these major problems regarding Sri Lanka's main cultivation, paddy.

Sinhala is the only language currently supported in this mobile application. Apart from Sinhala, this mobile application can be introduced to other languages such as Tamil and English. In the future development of the mobile application, wishes to add the Tamil and English language to handle this app. From time to time we must change the requirements of this application because the agriculture sector is rapidly changed every day. Finally, this mobile app achieves its objectives of "Connecting farmers to I-era." Since this mobile application is based on Android, in the future this can be developed to run on multiple platforms with the same content and functionality.

But with the improvements in the technology there are so many enhancements which can be integrated into the solution which few of them are explained below.

- Online delivery to Kem methods through the app.
- Awareness of all types of diseases affecting agriculture and other crops.
- Push Notifications via SMS to participants.

## References

- Azfar, S., -, A.N., Alkhodre, A.B., -, K.A., Mehmood, N., -, T.A., -, Y.A., 2018. Monitoring, Detection and Control Techniques of Agriculture Pests and Diseases using Wireless Sensor Network: A Review. *Int. J. Adv. Comput. Sci. Appl.* 9. <https://doi.org/10.14569/IJACSA.2018.091260>
- Chandrasiri, P.N., Ekanayaka, Y., n.d. "e-PaddySurv" - A Sustainable Crop Surveillance System for Sri Lanka Paddy Cultivation 6.
- Edirisinghe, J.P., Bambaradeniya, C.N.B., 2006. Rice Fields: an Ecosystem Rich in Biodiversity. *J. Natl. Sci. Found. Sri Lanka* 34, 57. <https://doi.org/10.4038/jnsfsr.v34i2.2084>
- Ginige, T., Richards, D., 2013. Design and evaluation of a mobile-based cultivation planning application for empowering Sri Lankan farmers 11.
- Heeb, L., Jenner, E., Cock, M.J.W., 2019. Climate-smart pest management: building resilience of farms and landscapes to changing pest threats. *J. Pest Sci.* 92, 951-969. <https://doi.org/10.1007/s10340-019-01083-y>
- Jankielsohn, A., 2018. The Importance of Insects in Agricultural Ecosystems. *Adv. Entomol.* 06, 62-73. <https://doi.org/10.4236/ae.2018.62006>
- Lou, Y.-G., Zhang, G.-R., Zhang, W.-Q., Hu, Y., Zhang, J., 2013. Biological control of rice insect pests in China. *Biol. Control* 67, 8-20. <https://doi.org/10.1016/j.biocontrol.2013.06.011>
- Nishantha, K.M.D.W.P., Sandika, A.L., Babu, A.G.C., Hettiarachchi, H.A.S.N., Pushpanjali, K., Abeytilakeratna, P.D., Nugaliyadde, M.M., 2016. Farmers' knowledge and attitudes on pesticide usage in vegetable cultivation in Sri Lanka. *Trop. Agric. Res. Ext.* 19, 244. <https://doi.org/10.4038/tare.v19i2.5350>
- Oman, P., 1968. Prevention, Surveillance and Management of Invading Pest Insects. *Bull. Entomol. Soc. Am.* 14, 98-102. <https://doi.org/10.1093/besa/14.2.98>
- Ravisankar, H., Sreedhar, U., Rao, N.S., n.d. A web based expert system for identification and management of insect pests of tobacco. *J. Entomol. Zool. Stud.* 5.
- Western Sydney University, Australia, Ginige, A., Sivagnanasundaram, J., 2019. Enhancing Agricultural Sustainability through Crowdsensing: A Smart Computing Approach. *J. Adv. Agric. Technol.* 6, 161-165. <https://doi.org/10.18178/joaat.6.3.161-165>
- Yamamura, K., Yokozawa, M., Nishimori, M., Ueda, Y., Yokosuka, T., 2006. How to analyze long-term insect population dynamics under climate change: 50-year data of three insect pests in paddy fields. *Popul. Ecol.* 48, 31-48. <https://doi.org/10.1007/s10144-005-0239-7>
- Yang, P., Iles, M., Yan, S., Jolliffe, F., 2005. Farmers' knowledge, perceptions and practices in transgenic Bt cotton in small producer systems in Northern China. *Crop Prot.* 24, 229-239. <https://doi.org/10.1016/j.cropro.2004.07.012>

Zhong, Y., Gao, J., Lei, Q., Zhou, Y., 2018. A Vision-Based Counting and Recognition System for Flying Insects in Intelligent Agriculture. *Sensors* 18, 1489. <https://doi.org/10.3390/s18051489>

**Acknowledgment**

For their kind cooperation on this research I would like to thank all the staff members

who are in agriculture field . In addition, all of my friends who have helped me get the answers from the various colleges, I want to thank.

## Implement Biometric Electronic Voting System in Sri Lanka

UP Muthukumara#, RMM Pradeep

*Faculty of Computing, General Sir John Kotelawala Defence University, Ratmalana, Sri Lanka*

#urajiepunsarani@gmail.com

**Abstract:** Web applications are the most popular platforms that deliver information and services through the Internet these days. This paper introduces Web-based Biometric Electronic Voting System Software to Sri Lanka. In the past few years happen a big improvement in the technology field. Here introduce the use of technology for voting system and presents the development and implementation of the electronic voting systems. In using this system, during the registration period, candidates, political parties, and voters are registered to the system. Biometric fingerprint machines scan the fingerprints of eligible voters and save them in the system. On election day, it processes to do verifications. The fingerprint is a biometric identifier. Because fingerprints are unique for every individual. In also they do not change. Automated biometric fingerprint identification can take considered the most reliable biometric technology that is used in the present society. This system replaces the paper-based traditional voting process. The electronic voting system is the best solution according to the situation in our country. Already some democratic countries have moved to these electronic voting systems because of many defectives that happened in the traditional paper-based voting system. Sri Lankans' contiguous country India also uses this electronic voting system. Sri Lanka is a democratic, developing country. Therefore, it better to go for a web-based electronic voting system for an efficient and secure election.

**Keywords:** Biometric, Electronic Voting System, Fingerprint, Verification, and Web-based application

### Introduction

In Sri Lanka, elections take place every five years to elect a President and the members of the parliament. Additionally, the provincial council elections and local authorities' elections are taking place in Sri Lanka. The election is a globally accepted method that is used to select representatives of the general public in a democratic system. Leaders from the regional level to the national level are selecting being selected by the eligible voters in the country. This happens with the interest of the people. Therefore, the decisive factor is the right of the voter. The heart of democracy is voting. The heart of voting is trust. However in the present that trust slip from people. People are disappointed with this voting system and about election violence. Most of the democratic countries, including Sri Lanka, also happened violence because of this paper-based voting system. Biometric electronic voting technology is the best solution for a credible election. In present most of the sectors in Sri Lanka are moved to online systems to improve efficiency. Therefore, this is an introduction to implement an electronic voting system in Sri Lanka. The traditional voting system moved to the electronic voting system will become a turning point in Sri Lankan political history. That will be a challenging task to change the mindset of people about the new system.

In the new method, this biometric electronic voting system will replace the paper-based

traditional voting system. There are many of violence happened based on this paper-based voting system. The electronic voting system will minimize these issues. The electronic voting system includes processes such as voters' biometric registration, candidates' registration, political party registration, voter verification, voting, vote counting, collation and publication of results. Behavioural and biological characteristics are unique for individuals. From automated recognition can identify these behavioural and biological characteristics. Biometric means using automated recognition individual wise identify the behavioural and biological characteristics. Biometric recognition is measuring an individual's behavioural and biological characteristics.

Fingerprints are used for personal identification. It is unique to everyone. No one has the same fingerprint. Twins also have different types of a unique fingerprint. Identical twins also no carry identical fingerprint. Fingerprints do not change from time to time. Every person born as a baby, and they grow. But there are no changes in their fingerprint. So automated fingerprint identification can take as most reliable biometric technology.

Introducing a software platform that will make election fair, authentic, accurate and fast is the aim of this research. There are many advantages to the biometric electronic voting system. They are high efficiency, high accuracy, time-saving, reduce storing difficulties, reliability, convenient to use. Difficult to forge access in the third party because illegal votes and repetitions are checked in the system.

### **Research Problem**

The paper-based traditional voting system includes many of issues. The main problems are it takes a long time for the counting process and delay in publishing results. According to records of previous elections it

took more than 12 hours to publish final results. Counting starts after the all ballot boxes bring to the counting centres from polling stations all around the country. Counting process starts maximum one hour after the closing polling stations.

Personal identity is another major defective of this current voting system. This is a common problem for most of the democratic countries. According to the personal identity problem, misused the ballot papers and vote duplication are the other problems that connected with it. In the election, the department has issued blue sheets additionally to the ballot papers. They used it to maintain a peaceful and calm election. But it is a disadvantage for the real voter. If issued a blue paper to the real voter, there is a problem with the personal identity of voters. Because of there is illegal third party access.

Other defectives in this current system are too much paper works, high labour intensive, high cost, transport Difficulties and high storing difficulties. And also it is not an eco-friendly method.

### **Literature Review**

This section contains the report about background researches of biometric electronic voting systems. Research has shown there are many defects happening based on this paper-based manual voting system. It is a common problem for most of the democratic countries. These papers describe the advantages and disadvantages of both the current and proposed systems. And also described different electronic voting systems and defectives in each system.

#### **A. Paper-based Voting System**

Piratheepan (2017) mentions that there are opportunities to occurring errors because of the current paper-based voting system in Sri Lanka count votes in manually. In counting

centres can be vote duplication, completely missed to count. And also mentioned sometimes votes can use in an improper manner and change the results favour of certain candidates. That is doing by some political parties.

This paper mentions an example of the injustice of the paper-based system. In the presidential election, found the ballot boxes filled with illegal ballot sheets. Used that illegal thing to appoint the president. Because of these illegal papers, that election became an invalid election. Because of non-evidence, cannot find theft and punish for thieves. The research mentions another example of American election injustice. At that time they used a paper-based voting system. During the election, some thieves printed the new white ballot sheets and quickly completed them and put it into the ballot boxes. It is an illegal activity. That activity shows that first world countries also suffered from this paper-based voting system.

Kumar (2011) has found a paper-based voting system is an inefficient method. Traditional systems take a long process and a long time. It has stationary costs and transportation costs. There is a chance to cast invalid votes. It required high human participation. Sometimes there can be human errors. Sometimes there are foxy election mechanisms.

Djanali (2016) has mentioned the counting process in the manual system it takes a long time. It takes several hours to declare the results. And also hard to determine when the result is true or not. Data sending in between two levels take several days.

Sedky (2015) has explained, regarding indicating high cost, less accuracy, and less transparency, are some of the problems in the paper-based voting system.

Gujanatti (2015) has explained that they indicate this is the common way to cast votes.

It requires more labour-consuming. It takes a long time. But easy to print ballot papers. Can store marked ballot papers for authentication.

#### A. Biometric Identifiers

Kumar (2011) has indicated the meaning of biometrics is the automated recognition of individuals. It is based on the behavioural or biological characteristics of the person. Biometric recognitions measuring an individual's suitable behaviours and biological characteristics. It helps to identify a specific user. The system uses a fingerprint as a biometric identifier. Fingerprints are unique to each individual. Fingerprints are not changed from time to time. Identical twins also haven't identical fingerprints. Fingerprints are the most common biometric identifier that uses nowadays. Automated fingerprint identification is the most reliable biometric technology. Because it has distinctiveness, persistence, ease of acquisition, and high matching accuracy. Biometric identifiers cannot be misplaced or misuse or share easily. It has better security. As an example difficult to forge access. Also, it having high efficiency.

Yinyeh (2013) has described the use of fingerprint, iris, face, palm print, speech characteristics define as biometric identifiers. Biometric identifiers cannot share or misplace or misuse. Fingerprints are unique to the individuals and it cannot be changed.

#### B. Fingerprint-based Electronic Voting System

Piratheepan (2017) has introduced the method of developing the fingerprint-based voting system using Arduino to Sri Lanka. Fingerprint electronic voting systems use human biometrics in the system. The fingerprint is unique for individuals. It is important identity of the voter. Fingerprint-based voting systems have simple architecture. A proposed device useful to

handles reliable and accurate election. Vote counts are the most important part of the election. If there is an issue, it impacts all societies and country. If it is a wrong result, people attitude for the current government is unpleasant. For that reason, the counting process should behave to reliable, accurate, and transparent. People have to feel confident after the election. To avoid the illegal activities happen in the paper-based current voting method have to introduce the "One Person-One Vote" method, an electronic voting system. Then can avoid the vote's rejection, from the wrong details. First, have to authenticate the voter, and that name is not a name in the cemetery or obituary column. Secondly have to authenticate, that voter has not voted previously in another polling station.

The voter has to fill a form with username and password. And also the National Identity Card Number (NIC) and fingerprint have to give to the system. National Identity Card Number (NIC) and fingerprint unique to every individual. Government database saves voters all information district wise. Then the database checks these details are correct. If there are correct details voters can cast their vote. Using fingerprint and National Identity Card Number legitimate voters can cast vote. In this system ballot sheet represent on the video screen. Can get help screens clicking on a button. Basically, this system has five steps. They are fingerprint enrollment, fingerprint verification, cast votes, alert for wrong voting, and generate the final report. This is a very easy method for voting. This voting system helps to decrease the voting process time.

The advantages of the fingerprint-based voting system are, it is a very user-friendly system. It rejects invalid votes. It responds very quickly. It reduces the time of polling and also reduces the staff required for the election duties. It is easy to carry the system

to the polling station. This system provides an accurate and easy counting method without any doubts.

There is the introduction of an electronic voting system to replace the manual paper-based voting system in Indonesia. According to their experiment, this system will able to prevent fraud. It can be a double vote (duplication of the vote) or improper addition to some candidates. An electronic voting system can speed up the counting process. The system is able to handle many kinds of attacks like sniffing, replay attacks, and falsifying voting results. This system can ensure the privacy of the voter and integrity of voting data (Djanali, 2016).

They designed this proposed system to support the conventional method. They designed the system to scan and stored the ballot paper on the local server after the voting. They ensure the flexibility of voter application. Have to ensure voter privacy. Use private and public keys for encryption. This application design for scanning paper ballots, count them, and send them to upper levels. They designed to develop web-based to desktop-based applications. For that they using java and C# languages. And they used a web service for communication between servers.

They conduct functionality testing using this application. And they conduct the other four security testing. The first one is to change the votes that going to send. It means using forge votes to test the system. Proposed system designed to check the signature of cheating votes before storing it to the database. Used HTTPS for protection of the communication line. They used Wireshark to sniff the network. The third test is done for a replay attack. It means cast vote twice. So that system checking the ballot number to avoid this problem. If someone sends the same vote using several ballot numbers, the system rejects the crafted numbers. Forth test is using vulnerability assessment tools to

identify the flow of the system. Used SQL Map to checking SQL injections.

In there grants an overview of the biometric electronic voting system in Ghana. Many African countries introduced the electronic voting system for their national election. A manual paper-based voting system is the major source that encourages violence in many democratic countries such as Ghana (Yinyeh, 2013). E-voting system defines rules for valid voting and declaring results in inefficient ways. Biometric recognition through the system improves voter identification. This system avoids fraud. The biometric e-voting system is cheaper than the long term paper-based system.

The proposed system includes many processes. They are biometric registration of voter, registration of the candidate, voter verification, electronic voting, vote counting, and declaring final results.

In the phase of voter registration, registered eligible voters into the system using fingerprint. The fingerprint machine scanned the finger and stored it voter's table in the database.

- In the candidate registration step, the individual person and the political party that fulfills the requirements that eligible for election are registered to the system and that data stored in the candidate's table in the database.
- In voter verification, a fingerprint recognition operated system to identify the voter. There are five stages of verification. They are the data acquisition stage, image processing stage, fingerprint image enhancement stage, feature extraction stage, and matching stage.
- E-voting phase, it includes an electronic ballot sheet. The ballot sheet includes candidate name, passport size photograph, and logo of a political party. Can select candidate clicking or touching

candidate name, photograph, or logo of the political party.

- In vote counting and result declaration phase, calculate the percentage of vote cast and publish the vote count and positions that they determined as soon as polling station closed. The result page displays the name of the candidate, a photograph of the candidate, total vote count for each candidate, percentage of votes, and the position of each political party.
- Used Microsoft Visual Basic 2010 at the front end and SQL Server database at the back end. And used a fingerprint scanning machine.

### C. Other Biometric Voting Systems

Sedky (2015) has done an overview of some of the e-voting systems in the United Arab Emirates (UAE). UAE conducted Federal National Council election sessions of the National Assembly using voting systems with biometric-based smart cards. They used a biometric-based smart card for verification of voters' identities. Voters have to visit polling stations and cast their votes. Then they send votes manually to the Abu Dhabi site.

### Methodology

The basis of the voting system is "One Person-One Vote". The main purpose of this biometric electronic voting system is to increase the efficiency of the counting processes and preventing fraudulent voting.

There are 3 stages in this voting process. These are the basic steps that include in three-stage.

There are 3 stages in this voting process. These are the basic steps that include in three-stage.

#### 1. Pre-Voting Process:

- Registration of Candidates
- Registration of Political Party

- Create Ballot Sheet
- Registration of Voters
- Fingerprint Enrollment
- Adding Election Division and Grama Niladhari Division
- Scheduling the Election Period in System

2. Voting Process:

- Fingerprint Verification
- Issuing Ballot Sheet
- Casting the vote

3. Post-Voting Process:

- Generating Final Result Sheet and Summary Sheet
- Declaring the Results

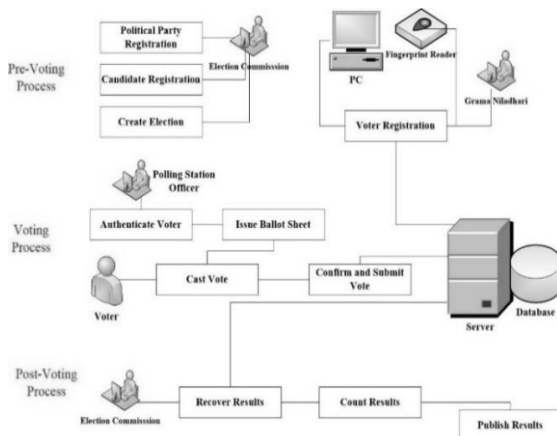

Figure 1: System Architecture

Source: Constructed by Researcher (2020)

**Registration of Candidates:** Election Commission nominated candidates will be registered to the system with name, NIC number, the image of the candidate, political party.

**Registration of Political Party:** Election Commission political parties will be registered to the system with political party name, political party leader name, and logo.

**Create a Ballot Sheet:** Election Commission will create the ballot sheet with candidate

names, political party names, and political party logos.

**Registration of Voters:** Grama Niladhari will be registered the candidates with name, date of birth, NIC number, gender, mobile number, Grama niladhari division, election division, and fingerprint. Scans the voter fingerprint using a fingerprint scanner machine. That data stored in the voter's table in the database. It will be used for verification on Election Day.

**Adding Election Division:** Election Commission will add election divisions to the system with the polling division number, polling division, electoral district, and electoral district number.

**Adding Grama Niladhari Division:** Election Commission will add with the grama sewa division number, grama sewa division, and election division to the system.

**Scheduling the Election:** Election Commission scheduling the election with election type, election date, election start time, and end time. After the end time of the election, automatically election will expire from the system. Under that reason, no one can vote after the election time from the system.

**Fingerprint Verification:** In Election Day, polling station officers verify the fingerprint of voter and issue the ballot sheet. The system will be checked about fraud voting. If there is any fraud voting, the system will block the system for that person and sends a message to the admin panel.

**Issuing the Ballot Sheet:** The polling station officer will issues the ballot sheet for the voter through the system after the verification of the voter.

**Casting the Vote:** Ballot sheet receives for voter after the verification. Voters have to click the vote button to cast the vote. If someone wants to cancel the vote, that person can verify the fingerprint. Doesn't



want to submit the ballot sheet. After the verifying fingerprint, no one can cheat using that person's fingerprint.

**Generating Result Sheet:** The result sheet will generate according to the count of the votes for each candidate. **Publishing Results:** Then Election Commission can publish the results.

Three categories have system access. Election Commission and Election Department, Grama Niladhari, and Polling Station Officer.

**Election Commission and Election Department:** Election Commission add the Grama Niladhari to the system by using the verification method. In the pre-voting process, they will be registered the candidates and political parties to the system and create the ballot sheet. Will add election divisions and grama niladhari division to the system. Then will schedule the election and add voters, candidates, and political parties to the election. The election will expire after the end of time. In the voting process, from time to time they can get a summary of the voting percentage. If there is an illegal vote, the system will block that votes. Then can identify fraud voters. In the post-voting process, can get a count of results and the system will generate the result sheet. The system will generate the count of the votes. Then they can publish the results. Result sheet publishes on web site.

**Grama Niladhari:** Grama Niladhari will add the polling station officers to the system using a verification security system. Grama Niladhari will be registering the eligible voters to the system. Among that can update the details of voters who dying and new voters to the system.

**Polling Station Officer:** Polling Station Officers verify the voters and issue the ballot sheets. If there is any person who trying to cast an illegal vote, polling station officers

can identify that person because of the system willing to block the illegal votes.

PHP, CSS, JavaScript, JQuery, and Bootstrap are technologies that will be used to implement the system. The fingerprint machine is the hardware component of the system. The fingerprint machine will store all data in the database.

### Data Analysis

Qualitative data analysis in this research. Collected information about the current voting system from the who participated in the election duty as SPO and chief accounting officer. Then interviewed employees who participate as a polling booth and counting officers. After that interviewed Grama Niladhari. SPO and chief counting officers were given details about all election procedures, rules, and regulations. What are the defectives in the current system and how to decrease these defectives within the system, what kind of actions can implement are they informed? Then collected information from voters using a questionnaire. A questionnaire distributed to several categories of people such as age group, financial status, education, and job status. The final result of that is 61.3% are not satisfied with the current system. 80.6% percentage agree for the newest system. That percentage said it is a suitable method for Sri Lanka and it is comfortable than the present system. And also they think the new system more efficient and reliable than the current system.

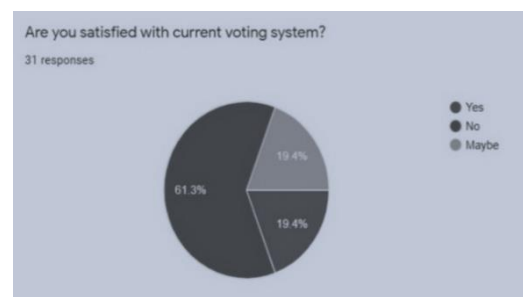

Figure 2: Feedback about current voting system  
Source: Constructed by Researcher (2020) in Google Form

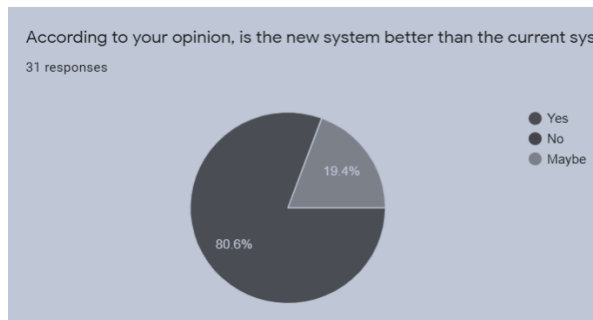

Figure 38: Feedback about Electronic Voting System  
Source: Constructed by Researcher (2020) in Google Form

## Results

The automated system is more efficient than the current system. Easy to register the voters, candidates, and political parties. The fingerprint is a more reliable technique for the voting process. The system will reduce the time and publish the results quickly. Accurate and reliable results generated by the system. The system rejects the all of illegal access and votes. After the voting period automatically system block the voting. This system provides many advantages to society.

Easy to analyze data from the output in the electronic voting system. All data will store in the database automatically. From that can filter the data very easily at any time. Can filter the data in any way. Using this system can identify the pattern of the votes easily. The comparison of the previous election results can get automatically. Quickly can get the comparison results of the elections. This system will give an efficient and secure output.

## Discussion

Biometric Electronic Voting System more efficient and secure than the manual paper-based system. Because it will reduce the counting time and biometric identifier act as a barrier to the illegal votes. It is the main advantage of this system. Votes will pass to the database and it will give the final count in quickly. The system will generate a summary of the result sheet and display it on the web site. This system introducing for the

presidential election. In a further development, can improve the system for all elections in Sri Lanka. As well as the ballot sheet can issue in Sinhala, English, and Tamil languages.

## References

- A. Piratheepan, S. S. (2017). Fingerprint Voting System Using Arduino. Middle-East Journal of Scientific Research 25 (8): 1793-1802, 2017 , 10.
- A. Piratheepan, S. S. (2017). Fingerprint Voting System Using Arduino. Middle-East Journal of Scientific Research 25 (8): 1793-1802, 2017 , 10.
- D. Ashok Kumar#1, T. U. (2011). A Novel design of Electronic Voting System Using Fingerprint . INTERNATIONAL JOURNAL OF INNOVATIVE TECHNOLOGY & CREATIVE ENGINEERING (ISSN:2045-8711) , 8.
- M.O Yinyeh, K. G. (2013). Overview of Biometric Electronic Voting System in Ghana . International Journal of Advanced Research in Computer Science and Software Engineering , 4.
- Mohammad Hosam Sedky, E. M. (2015). A Secure e-Government's e-Voting System. Science and Information Conference 2015, 9.
- Rudrappa B. Gujanatti, S. N. (2015). A Finger Print based Voting System . International Journal of Engineering Research & Technology (IJERT) , 6.
- Supeni Djanali, B. A. (2016). Design and Development of Voting Data Security for Electronic Voting (E-Voting). 2016 Fourth International Conference on Information and Communication Technologies (ICoICT), 4.
- Supeno Djanali, B. A. (2016). Design and Development of Voting Data Security for Electronic Voting (E-Voting). 2016 Fourth International Conference on Information and Communication Technologies (ICoICT), 4.

## Acknowledgement

Sincere gratitude to all the personals and institutions given me the required data for this research and gratitude for all lecturers given me the advice.

### Author Biographies



Urajie Punsarani  
Muthukumara is a student in  
Sir John Kotelawala Defence  
University, following BSc.

(Hons) Information System degree in this  
university.

## Survey on wearable sensor technologies on driver drowsiness detection

P.D.S.T Gunathilaka# and P.Kalansooria

*Department of Computer Science, Faculty of Computing, General Sir John Kotelawala Defence University*

# sathygu95@gmail.com, Sri Lanka

**Abstract:** Intoxicated driving is dangerous, drowsiness is another form of fatigue which claims hundreds of lives every year in fetal crashes. US National Highway Traffic Safety Administration has estimated that a total of 100,000 vehicle crashes each year are a direct result of driver drowsiness (Anon., n.d.). In order to prevent from these devastating accidents we should identify the drowsy moment and control it before mishap happen. For that driver drowsiness state should be monitored. But detecting drowsiness using face image behavior or drivers eye blinking is not accurate enough. Though we can measure rapid eye movement sleep and slow eye movement sleep, we cannot measure no eye movement sleep. Researchers have found that eye open sleep is quite common, so this human drowsy behavior also should be measured through the system (Anon., 2019). After analyzing drowsy behavior, has classified as normal, slightly drowsy and highly drowsy. Mention drowsy detection methods identify drowsiness when highly drowsy. But it's rarely possible to prevent from the highly drowsy state. Even if they prevent from that, it's too late to prevent from mishap. So the exciting drowsiness detection system is absolute. Now we have accurate sensors to detect heart rate, EEG, EOG Etc. Through those we can measure drowsiness in normal and slightly drowsy states where it's possible to prevent from mishap. Sensor signals will be processed by the desktop application and identify whether the driver is drowsy or not. For more accuracy, place the sensor in the steering wheel. The aim is an accurate

drowsiness detection system which covers the weakness of absolute systems.

**Keywords:** Drowsiness Detection, No-eye movement, highly drowsy, heartrate.

### Introduction

A road accident occurs every 10 minutes in Sri Lanka (Mirror, 2018). More than six or seven lives are always in danger. According to available statistics 150 admitted to hospital a day. National Council on Road Safety statistics proved that 18980 road accidents occurred from January 2017 to June 2017. From those 1473 had caused fetal injuries and 1547 had caused deaths (Anon., 2019).

Year	Fetal crashes	Small injuries	Serious injuries	Deaths
2012	2317	14680	7209	2444
2013	2190	13525	6870	2362
2014	2260	12781	7071	2440
2015	2600	13595	8186	2816
2016	2798	13961	8518	2961

Figure 1: details about fetal crashes in Sri Lanka (police media unit)

According to accidents happen between 2012 and 2016 more than 20,000 lives are lost each year. Not only Sri Lankan statistics, but also organizations such as National highway traffic administration (Anon., n.d.) and World health organization also proved that these devastating accidents are direct result of driver drowsiness (Hanwella, 2018). US National Sleep Foundation statistics reported that 54% of adults have driven in drowsy mode and 28% from them were actually sleeping (Anon., 2019).

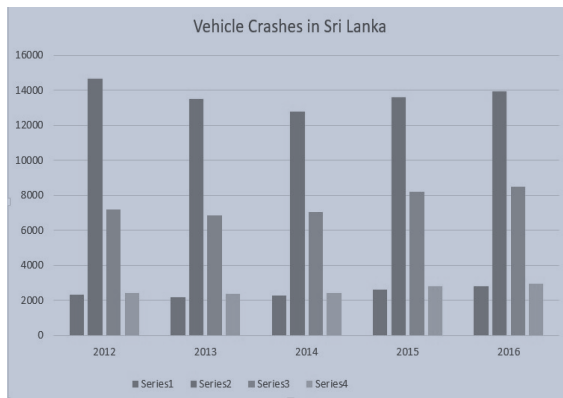

Figure 2 chart of yearly vehicle crashes to above chart

As mentioned in figure 2, every year number of accidents are increasing. The main cause of these accidents are fatigue, drowsiness, monotones and alcohol. From these, drowsiness is the most devastating problem. So, it's necessary to make a drowsiness detection system to prevent from these devastating mishaps.

So to prevent from these accidents most of the researches had made a drowsiness detection system by caring 3 main measures. They are vehicle based measures, Behavioral based measures and Physiological measures. In vehicle base measures they measure the drowsiness using lane position, steering wheel movement, etc. In Behavior based measures driver behavior was analyzed using yawning, eye closure, eye blinking, etc. In physiological measures they measure the drowsiness through heart rate, pulse rate, ECG, EEG, EOG etc. (Arun Sahayadhas, 2012).

Figure 3, 4, 5 shows mention 3 kinds of measures current systems. Here vehicle based measures and behavior based measure recognize the drowsiness when the drivers are in a deep sleep. So, it's too late to avoid from accident even if they are alerted.



(Figure 3 research based on vehicle based measures, Figure 4 behavior based measures based research, Figure 5 physiological measures based measures)

But physiological measures measure driver drowsiness when driver is awake to asleep stage. So physiological measurement is a good measurement when compare to other two. In physiological measurement also has two kinds of components. They are wireless components and wired components. When there is a wired component it's intrusive to the driver. But when it is wireless its non-intrusive. Sleep also can be categorized as awake, non rapid eye movement sleep (NREM) and Rapid eye movement sleep (REM). Detecting drowsiness when the drivers eyes are open (NREM) is a critical point in drowsiness detection (Arun Sahayadhas, 2012). If research use vehicle based measures and behavior based method to driver drowsiness detection, its impossible to measure non rapid eye moment sleep. So the research is not covering all type of subjects, but if system use physiological measures to measure driver drowsiness it's possible to identify NREM sleep. So rest of the research use physiological measures to detect drowsiness.

In Section II of this paper, a literature review on drowsiness detection system and other methods are presented. This is followed by a description of the methodology used in Section III. Comparison of the existing system is presented in section IV. The proposed solution is stated in Section V. The conclusion of the study is given in Section VI.

### Literature Review

Many methods have been employed to identify Driver Drowsiness out of which a selected number from the literature are reviewed in the section.

In the literature drowsiness had been detected using three main measures. Vehicle based measures, behavior based measures and physiological measures are them. Some Researchers have recognized the drowsiness using deviation from lane position, Movement of steering wheel and pressure in the acceleration pedal etc. However, these sorts of measures are poor predictors since these changes also could be happening because of alcohol and drugs. (Arun Sahayadhas, 2012).

Behavior based measures, such as eye closed, yawning and head bending also had been used to detect drowsiness. The aim of that project was to build a model of drowsiness identification framework .Through this framework they collect the pictures and measure the condition of eye, mouth ratio and head node rate as a predetermined calculation .For implementing this framework some of OpenCV libraries were utilized including Haar-cascade .The target has achieved by processing video images by OpenCV. The Outcome of the video was used to determine drowsiness level and then provide warning to the drowsy driver. As they mention drowsiness can be measure using manual and automatic approaches. Manual method is not efficient .it could cause accidents because it's based on human perception of the situation .According to this project head bending is the final state to detect drowsiness but it's too late to prevent from accidents (Shreya A Kulkarni1, June 2019 ). But this research can be used for other occasions such as detecting class room sleepers or for night workers to detect whether they are sleeping or not. All the movements are caught through the camera's so whole thing depend on the availability of lighting and speed of image processing on video. So this research has proved that behavior based measures are poor

predictors to measure driver drowsiness (Shreya A Kulkarni1, June 2019).

Physiological based method detect drowsiness by using driver's physiological signals such as ECG, EMG, EEG, EOG etc. Even though these predators are good, it's not comfortable for a driver to ware such a device .So Researchers has develop a smart seat belt that sense heart rate to combat driver fatigue (Pai, 2014).The target of implementing this project was to overcome some of the weakness such as not adjusting for noise and vibrations and some products asking wearable. Here they have realized that heart rate and breathe rate as good indicators (Pai, 2014) .As they were targeted drowsiness was measured unobtrusively. According to their research attach a sensor in to a car which is already initialized also a challenging task. Some companies had used ECG sensors for vehicles and had crashes resulting from it. So as they mention we need to make the ideal trade when we select sensors to the sheet belt.

The latest release of wireless wearable devices is biosensors .Through this we can measure people's physiological data .In this paper they have use a wearable bio sensor called bio Harness to detect driver drowsiness. bio Harness is produced by Zephyr technology (Brandy Warwick1, 2015) .They have carry out the system using two phases .In the first phase it collect driver physiological data using bio sensor and analyze the measured facts to find the key parameters related to drowsiness. In the second phase it design a drowsiness detection algorithm, then a mobile app to alert driver. In this research also they have proved that breathing rate and heart rate are related to drowsiness .According to their experiment there is an objective increase in their heart rate and decrease in breathing rate (Brandy Warwick1, 2015). The device with the sensor has to wear close to chest while he is driving .So if the analysis data

passed certain threshold the driver will be alerted. Here the device has to wear separately so it disturb normal flow of driving. Though we can measure heart rate, heart beat to beat interval, breathing rate, posture, activity level, peak acceleration, respiration rate, heart rate and RR interval has a significant varies between different stages of drowsiness. When driver move from awake state to drowsy state ratio of Low Frequency to high frequency decreases progressively. Even though, Heart rate variability is a good indicator but bio harness 3 doesn't report it (Brandy Warwick1, 2015).

An algorithm has improved to drowsiness detection for non-intrusive driving. There they have use sensor parameters to detect drowsiness. They mainly test the sources such as head movement, steering grasping and driving under influence of alcohol. If one of these conditions prevail it recognize the person as a drowsy one. According to the calculations probability of accident could be increase when alcohol in the blood is beyond 0.08g/100ml (Ratnarup Dey, 2018). They use Load cell, Alcohol Sensor and Accelerometer to detect above mention characteristics. Load cell measure the force with the steering wheel driving. The three axis accelerometer is used to detect irregular head movement. Breathalyzer is used to estimate the alcohol level in the blood and it was measured through breathing. In the implementation algorithm they have use Arduino programming language by merging C and C++ functions (Ratnarup Dey, 2018). But taking 10 second to capture one breath has taken as a limitation of that project. Not only that ,driver not being with in the 10 centimeter from the sensor could also cause not detecting drowsiness .The current sensor which use in the existing system also not detecting alcoholic content in the drivers breath if the driver is in their driver position.

Another research has conduct for non-contract sensing platform to detect

physiological signals of the driver. There they have mainly focused on electrocardiogram (ECG) and electroencephalography (EEG) .Using this monitoring system we can monitor on set and extent of drowsiness. Physiological signals are a good indicator. But conventional bio electrical signal measurement need electrode to be connect to human body. If we use that to normal driver drowsiness detection it affect normal driver operation .So it is not effective for long-term monitoring. So In this project they have use a non-contract ECG sensor which use high input impedance circuitry .Using this effective sensor we can measure electrocardiography(ECG) ,breathing and eye blinking .In this sensor package ECG signals effectivity work up to 30cm away from body (Dr. Xiong (Bill) Yu, 2012 July) . The sensor which they use here is validated on high fidelity driving simulator .Here they have used digital signal processing algorithm to reduce the noise and automate signal analysis .Using measured physiological signal (heart rate, heart rate variability, breathing frequency and eye blinking frequency) we can measure driver fatigue .To achieve high reliability, drowsiness indicator has developed by coupling several physiological parameters. Evaluation of sensor has conducted under various conditions such as ordinary laboratory and official environment conditions. Performance of this sensor also monitored using high fidelity simulators and operational truck. As they say this sensor technique also can be applied for railroad train operators and truck drivers.

A Smart car seat has design for drowsiness detection based in pressure distribution of the drivers body (Ines Teyeb, 2018 April).They have use mesh of pressure sensors to cover the sheet surface. From these sensors they have highly care about head support sensors and back cushion

support sensors. After analyzing the pressure distribution they take two decisions which are zero pressure state and high pressure state. For measuring pressure they have use a fundamental physical concept of pressure .In the algorithm they have mention 3 sitting positions and the pressure distribution of it. Then they have created a table which contain result of sitting position recognition .This research totally contain the details about recognizing movement. Through that they say driver is in a fatigue mode when he is moving to right. However to confirm drowsiness they ask to combine eye state based wavelets networks. As for further work they ask to develop a multi-parameter vigilance monitoring system by combining heart and breathing rate (Ines Teyeb, 2018 April).

A review has been released from the Tezpur University based on “correlation of drowsiness with electrocardiogram”. There they used ECG signal to measure driver’s drowsy behavior. According to their study spectral analysis of HRV signal cause different frequency bands. From those Low frequency band and high frequency band can be used as input to measure drowsiness state (Ananya Bonjyotsna and Sanjay Chandra Roy, 2014).

### **Research Gap**

The proposed research solution is different rather than above mentioned existing products because I’m using Non-rapid eye movement sleep detection which they did not use. For this research my measuring point is heartrate using pulse sensor to identify driver drowsiness which did not use for previous researches.

### **Aim**

Identify driver drowsiness accurately and efficiently in awake to drowsy state.

### **Objectives**

- To identify drowsiness using physiological measures, Heartrate viability.
- To develop algorithm to identify drowsiness using FFT.
- To identify whether driver is drowsy or not.

### **Motivation**

All the human beings are busy with their own lifestyles under these evolution of technological era. None of the human beings are physically and mentally fit to live a balance life. They don’t have mental rest. Most of the time people get drowsy when they are driving, this cause most of the motor accidents. I personally faced the same experience when I was driving. It drives me to motivate to do this research to avoid motor accidents and saved the human life.

### **Methodology**

Initially, statistical data on drowsiness detection in Sri Lanka was obtained from police media unit reports and newspaper articles .Other than that National Council on Road Safety statistic data also taken to prove the increment of accident due to drowsiness. National highway traffic organization and World health organization data also directly proved that these divesting accidents directly cause by drowsiness. So introduction was directly based on above statistical data. For searching purposes the keyword “wireless drowsiness detector”, “physiological based drowsiness detector”, “Detect drowsiness using heart rate and respiration” were used either together or separately.

Altogether eight journal articles were obtained from the literature review. Research papers for the reviewing of existing systems were accessed and obtained from google scholar, Scientific Research publishing, Sci-Hub and international



research conference etc.” Wireless drowsiness detector” or “Detect drowsiness” were the key words used to retrieve the research papers. Attempt to retrieve some research papers through databases such as IEEE Explorer, Web of Science and Scopus were unsuccessful due to logging restrictions. And also some papers were partially visible due to login restrictions. This cause missing some of the valuable information. The selections were based on the date of publication and inspecting abstract and the content body. Some of the papers had to drop out due to lacking relevant information and uncertainly about authenticity .Altogether eight papers were selected for the review. The aim and goals of the selected research paper were used for this study along with the method and result.

### Comparison

As we mention in the literature review many method had been implemented to detect drowsiness. From those Vehicle based and behavior based measures are not good indicators to measure drowsiness. All the mention researches has proved physiological measures as a good drowsiness indicator. Drowsiness based research had used different technologies such as Fast Fourier transform, signal processing, video image processing, pressure analyzing etc. From these Fast Fourier Transform is more efficient than other technologies. In the above mention researches, drowsiness had been measured through physiological measures such as breathing rate, heart rate, EEG, ECG.

Table 7 : Literature review summary

Descripti on	Use physi ologic al based measu res	Pub. Yr.	Type of physiological measures which use in the project	Techn ique use for drows iness detect ion
<b>Driver Drowsine ss using wireless wearable</b>	True	2015	Bio sensor to measure (heart rate, heart beat to beat interval, breathing rate, posture ,activity level ,peak acceleration , respiration )	Fast Fourie r Transf orm.
<b>Non-Contact Driver Drowsine ss Detection</b>	True	2012	EEG,ECG	Digital signal proces sing algorit hms
<b>Smart Seat belt</b>	True	2014	Respiration, heart rate	Signal proces sing
<b>Drowsine ss monitorin g</b>	False	2019	- They use condition of eye, mouth ratio and head node rate.	Proces sing video images using opencv and haar-cascad e
<b>Improved algorithm for drowsine ss Detection</b>	False	2018	- Head movement and steering grasping	Arduin o by mergin g C and C++
<b>Smart car seat design for pressure distributi on</b>	False	2018	- Use body pressure	Pressu re analyzi ng techni ques
<b>Correlatio n of drowsine ss using ECG</b>	True	2014	ECG	Fast Fourie r Transf orm

But according to above researches, using heart rate to measure drowsiness is more accurate than other physiological measures. Most of the research also had mention this

measurement as good indicators. Even though people can use wired and wireless devices to detect drowsiness. Wireless detection is more unobtrusive. Detecting fatigue through pressure distribution is a new approach. It can detect driver movement but cannot exactly say whether driver is drowsy or not. So it's not enough to prevent from crashes. So up to best of my knowledge, using wireless sensor like heart rate detecting sensor & Fast Fourier transform technique is best way to detect drowsiness.

### Proposed Solution

After reviewing existing research based on drowsiness detection I came to know that driver drowsiness detection is still not accurate enough. So I proposed to make a wireless drowsiness detection system to identify driver's drowsiness. Since the Heart rate is the best measure to detect drowsiness, I'll create a heart rate detecting module using Nodemcu and pulse sensor. Then the system will use Arduino code to publish the data in the MQTT Cloud. The python based application is used to subscribe these data and do future processing using fast Fourier transform to detect drowsiness. Using the key parameters like low frequency to high frequency ratio and drowsiness detection algorithms we can confirm driver drowsiness. Finally system will give a system notification saying driver is conscious. Since we alert the driver in the awake to sleep state driver can prevent from it. Even the drivers who sleep non rapid eye movement also can detect their drowsiness clearly and can prevent from it. So most of the accidents will decrease through that.

### Conclusion

Yearly number of vehicle crashes are increasing. After analyzing reason behind that researchers came to know that it's direct result of drowsiness. Number of deaths related to drowsy driving is increasing

because of not having a proper and accurate drowsiness detection system. Existing systems has measure drowsiness through three type of measures such as vehicle based measures, behavior based measures and physiological based measures. Vehicle based measures has detect drowsiness through deviation from land position, steering wheel movement etc. But as I mention in the literature review it's a poor predictor to detect drowsiness. Behavior based measures detect drowsiness throw eye blinking, head movement, yawning type of behaviors. Since all the measurements are grab through cameras drowsiness level is depend on the angle of the camera and camera quality. Not only that, it detect drowsiness in the last state of drowsiness. So, even they have detected drowsiness it's too late to prevent from accidents. So we can say it also as a poor predictor. But physiological measures detect drowsiness through driver's physiological states such as ECG, EOG, EEG, Heart rate, respiration etc. Since it detects drowsiness before the final state of drowsy it can prevent from a lot of accidents. And also it measure not only the rapid eye movement sleep it also show the non-rapid eye movement sleep. So physiological measures are a good indicators. From physiological measures heart rate has a special important since it shows a proper variation when convert to frequency domain. For monitoring these two type of measurements we can use wireless and wired sensors. From that wireless sensors are good because it's non-intrusive. Even though a different type of sensors are there bio sensors plays a major role when detecting heart rate. These sensors could be embedded in sheet or sheet belt or as an external device. But sheet embedded sensors could cause accidents because embedding sensors to an already initialized vehicle could change the balance of the vehicle. So embedding devices in to vehicle sheet is dangerous. But we can add the device in to the steering wheel. Then we need a signal

processing and analyzing unit to detect drowsiness for that we can use a monitor. This desktop monitor based system detect the drowsiness and give a system alert.

### Reference

Anon., 2019. National Council for Road Safety. [Online] Available at: [http://www.transport.gov.lk/web/index.php?option=com\\_content&view=article&id=90&Itemid=191&lang=end](http://www.transport.gov.lk/web/index.php?option=com_content&view=article&id=90&Itemid=191&lang=end) [Accessed 20 09 2019].

Anon., 2019. National sleep foundation. [Online] Available at: <https://www.sleepfoundation.org/> [Accessed 17 09 2019].

Anon., 2019. National Sleep Foundation. [Online] Available at: <https://www.sleepfoundation.org/articles/myth-and-facts-about-sleep> [Accessed 21 09 2019].

Anon., n.d. national highway traffic safety administration. [Online] Available at: <https://www.nhtsa.gov/road-safety> [Accessed 15 September 2019].

Arun Sahayadhas, K. S. a. M. M., 2012. Detecting Driver Drowsiness Based on Sensors: A Review. *journal/sensors*, p. 17.

Brandy Warwick<sup>1</sup>, N. S. X. C. K. X., 2015. Detecting Driver Drowsiness using Wireless Wearables. Rochester, NY, s.n.

Dr. Xiong (Bill) Yu, P., 2012 July. Non-Contact Driver Drowsiness Detection System, Cleveland, OH : Transportation research board of national academy.

Hanwella, P. R., 2018. The Sunday Times. [Online] Available at: <http://www.sundaytimes.lk/180520/mediscene/read-this-andhave-a-good-nights-sleep-294295.html> [Accessed 16 09 2019].

Ines Teyeb, O. J. M. Z. a. C. B. A., 2018 April. Towards a Smart Car Seat Design for Drowsiness Detection Based on Pressure Distribution of the Driver body. Tunisia, Research gate.

Mirror, S. L., 2018. A road accident every 10 minutes!. [Online] Available at: <https://srilankamirror.com/news/6874-a-roadaccident-every-10-minutes>

Pai, A., 2014. Researchers develop smart seatbelt that senses heart rate to combat driver fatigue. s.l., s.n.

Ratnarup Dey, J. P., 2018. An Improved Algorithm for Drowsiness Detection for Non-Intrusive Driving. Bengaluru, Karnataka, India, International Journal of Applied Engineering Research.

Shreya A Kulkarni<sup>1</sup>, D. S. S. K., June 2019 . Driver Drowsiness Monitoring System. , Bangalore, India , International Research Journal of Engineering and Technology (IRJET) .

Ananya Bonjyotsna and Sanjay Chandra Roy (2014). Correlation of Drowsiness with Electrocardiogram : A Review. [online] Available at: <https://www.semanticscholar.org/paper/Correlation-of-Drowsiness-with-Electrocardiogram-%3A-Bonjyotsna-Roy/602394553991cd7bf1d026e4e8777cf22e88114a> [Accessed 29 Jul. 2020].

## Analysis on emotion classification methods

IO Goonewardena# and Pradeep Kalansooriya

*Faculty of Computing, General Sir John Kotelawala Defence University, Rathmalana.*

isuriosadi@gmail.com

**Abstract:** Emotional intelligence is the ability to understand changing states of emotion, it is an important aspect of human interaction. With upcoming developments emotion identification is an important aspect in HCI. Ideally if a computer can identify a human's emotions and respond to it accordingly human computer interactions would be much more natural and more convenient. But even from a human's perspective emotions are hard to identify and track, hence for a computer to identify accurate emotions can be challenging.

Nonetheless there exists few methods to classify and label emotions into categories. Hence this research is an analysis of methods used to classify emotions. Discussing the strengths and weaknesses in communication cues such as facial expression classifiers, gesture movements, acoustic emotion classifiers and emotion mining in text. It argues that there exists an increment of accuracy when two or more systems are paired to extract the features in different situations. Hence results show that, while each model has its advantages and disadvantages, when integrated to classify, it gives better, more accurate prediction and improved results. Additionally, this paper mentions some of the practical issues that exist when it comes to emotion recognition and HCI. Furthermore, it is identified that emotion identification via text is a research area which holds great potential and among many approaches hand crafted models with the use of machine learning gives the best results. Finally, it proposes a solution, a mobile application for emotional support

using emotion identification via text messages.

**Key words:** modules, unimodal, bimodal, multimodal, emotion mining

### Introduction

As we have identified 'emotions are a set of mental states' which is connected to human nervous system, controlled, or initiated by the change of various chemicals associated with a human's conscience. The train of thought, or feelings with the change of agreement or disagreement, the variation of happy and sad can cause these changes chemically in the brain, which influences humans their psychological and physical behavior. And as they change we identify these mental states as emotions. As we try to identify these emotions using neuroscience, psychology or using technology, what we need to understand is that emotions are complex.

The skill or capability of a human to identify their own emotions as well as others, to differentiate one emotion from the other, as well as to act according to them is called 'emotional intelligence'. Emotions are usually confusing. Even for humans to identify their own emotions it takes some effort in differentiating on what they actually feel. As for identifying other people's emotions it is much more complex. Psychologically emotions are identified mainly through facial expression. And since the day we were born, we humans have also generated or experienced different kinds of emotional states and through emotional intelligence have gained the ability to identify them while they change.

Psychologists have tried to identify the basic emotions of humans. But as we all know, our emotions cannot possibly be limited to few adjectives, for what one may feel, may be different from the other individual or it may even be hard to identify at all. According to different psychologists they have identified several emotions, in the late 1970s psychologist Paul Eckman identified and classified emotions in 6 different types. They are happiness, sadness, disgust, fear, surprise, and anger. (Physician, n.d.) Robert Plutchik defines a diagram, a wheel of emotions which connects 8 basic emotions and pairing to it is its variation according to the intensity. So, for one emotion it maybe a variation or a combination of one or two many basic emotions. Accordingly, in this color wheel there maybe thousands of different emotions, which are identified or even not, but for understanding we can define that each emotion can be a variation of those basic emotions. For an example happiness or content with trust may combine and define an emotion called love. Just as that there maybe other variations or combinations of emotions. Even though later expanded through research in to more emotions, these are discussed as the basic emotions of human beings. These emotions have a frontal effect on human actions. According to changing emotions humans change their actions, perspective and decision making.

When considering on how humans identify emotions, we use facial expressions, speech, gestures, and a combination of all sensory information along with past knowledge and memories. Also, with the use of natural languages we tend to communicate with other people and machines using text. Using these methods, we are capable of identifying our own emotions as well as others. For the 6 basic emotions identified by Paul Eckman we come across different traits in each modularity to identify them and to

differentiate emotions, such as we identify happiness through the smiling facial expression, relaxed stance, and through the chirpy voice. And in textual content we can identify the emotions of humans more frequently according to context. But, in some cases it is identified that if one modularity is missing for humans it could cause confusion or misunderstanding for which emotion is expressed. As an example, text messages even though widely used in many applications may have less impact on the receiver as for it is less emotion ridden.

With upcoming developments emotion identification is an important aspect in HCI. Ideally if a computer can identify (distinguish, analyze, articulate or regulate) a human's emotions and respond to it accordingly human computer interactions, communication between a user and a computer would be much more natural for it would understand if the user is satisfied or dissatisfied, then making it more convenient. Hence for a human computer interaction to be successful, at its best state, the most important factor for a computer or machine is to first identify its users' emotions. And according to the classification it creates many opportunities for new technologies such as emotional support and therapy applications. But in implementation as discussed even from a human perspective emotion are hard to identify and track. Even with face to face observation and interaction emotions can be deceiving, confusing and misinterpreted, hence for a computer to identify accurate emotions can be challenging. Nonetheless there exists few methods to classify and label emotions into categories.

In this paper it discusses the modularity's which we can identify emotions such as facial expressions, speech analysis, gesture recognition and text messages. This paper discusses some of the research done from each method as well as their limitations and

advantages of each modularity. Also, for further analysis it discusses about the combinational bimodal systems as well as multimodal systems and the advantages in using it. Finally, it discusses emotion identification via text messages and proposes a system to provide emotional support using a mobile application.

In the next section the experiments done for each modularizes are discussed with respect to automatic emotion recognition such as speech, facial expressions, gesture (unimodal systems) as well as bimodal systems with the combinations of face, speech and body, and multimodal automatic emotion recognition systems. Also, emotion identification via text messages is identified as a promising research area hence in the next section it is discussed the methods they have used; mainly technologies; experiments they have done and the results they have concluded to.

### Literature Review

#### A. Speech Emotion Recognition Using Deep Neural Network and Extreme Learning Machine

When considering speech recognition Kun Han, Dong Yu and others have proposed a system for emotion recognition using the speech module from low level acoustic features and using utilized deep neural networks (DNNs) and extreme learning machine (ELM) for development. It is identified that with the ability of a DNNs to feed and to classify data with raw yet sufficient features it is capable of learning high level representations. Then by feeding the segment level features to the ELM which is one simple layer of neural network the system can then identify/classify the utterance level emotion state. The experimental results taken, indicate that there is an increment in performance of 20% when comparing with HMM (Schuller et al., 2011) based methods or SVM emotion recognition.(Han et al., n.d.)

#### B. Facial expression mega mix: Tests of dimensional and category accounts of emotion recognition

When considering face recognition Andrew W. Young, Duncan Rowland and others have proposed four experiments to investigating the perception of photographic continua of morphed facial expressions for the 6 basic emotions which are happiness, surprise, fear, sadness, disgust and anger as identified by Eckman. Experiment 1 was an effort to identify morphed facial expressions photographed by all continua between pairs of the six emotions. Experiment 2 had the alternative response of 'neutral' which would be the midpoint of certain continua, with the understanding that midpoints of certain continua might be more of neutral than an actual emotion of 6 emotions. Experiment 3 demonstrates the best identification of pairs of stimuli (The six continua forming the outer hexagon) falling across category boundaries. Experiment 4 was done by asking the subjects to rank the order the emotions, it may be morphed in to by their guess/approximation. This was to explore the nature of within category discriminability for identifying if the subjects can identify which direction an emotion is deriving or changing in to. Therefore Experiments 1-3 showed results for within category and 4 was to explore it furthermore, which produced evidence that subjects did in fact had the capability to identify which emotions are combined into the morphed images. Hence, they suggested rapid classifications of prototypes as well as better across boundary discriminability to understand the human abilities of classification.(Young et al., 1997)

#### C. Technique for automatic emotion recognition by body gesture

When considering gesture recognition Donald Glowinski, Antonio Camurri and others identifies the techniques for automatic emotion recognition through body

gestures, that is the upper body which consists with head and arms. Only four emotions were considered here (anger, joy, relief, sadness). For this research professional actors were taken as subjects and when gathering data, a layered approach was taken from gathering low level features (speed of movement, position) to more effective and descriptive features which consists all gesture movement features(directness, impulsiveness). Through these features information was derived as well as further feature extraction was done by statistical and computer engineering methods. Through this experiment they have identified that without the body markers and with very flexible environment that energy cues as well as perimeter cues are significant in emotion recognition via gestures.(Glowinski et al., 2008)

#### D. Bimodal emotion recognition from expressive face and body gesture

As we know we have five sensory instruments to recognize, process and to understand inputs accurately, it is also said that if at least one input is lost there may be a change in differentiating even for humans, hence Hatice Gunes and others proposes a vision based bimodal emotion recognition method using face recognition and body gesture (upper body). As for methodology, they captured images for all emotions of the face and upper body and analyzed both frames individually then later on combining their classification at a decision level. Both models were trained separately and classified in to labeled emotion categories. As for combining/ fusion of results it was done at two levels, before classification and at decision level. As for results it shows that recognition accuracy is much better than a unimodal method. Future work would be to pair up different modalities for different results.(Gunes and Piccardi, 2007)

#### E. Multimodal emotion recognition in speech-based interaction using facial expression, body gesture and acoustic analysis

As discussed, bimodal automatic emotion recognition shows far better performance as for unimodal systems, hence Loic kessous and others have analyzed the combinations of bimodal modularity's as well as multimodal automatic emotion recognition combining all three facial expression, speech based and body gesture. For the corpus 10 people were gathered to pronounce a sentence while describing 8 different emotions. Also, there is an added feature for that is, the database includes native languages such as French and Greek. As for methodology Bayesian classifier was used for differentiating emotions. Unimodal of facial recognition, speech acoustic analysis as well as gesture was taken. And as for bimodal modularity's the combinations of face-gesture, face-speech and finally gesture-speech was taken and lastly the multimodal automatic emotion recognition was done for all 3 modularity's. This research shows that as for unimodal system body gesture data shows the best performance of 67.1%. also the main objective of this study was to evidently prove that using multiple modalities can increase the performance of automatic emotion recognition system, that is shown by the result of 3.3% recognition improvement over the best bimodal result.(Kessous et al., 2010)

#### F. Emotion identification via text and the importance of perspective and context.

When considering emotion identification through textual content, there is classification of emotions as well as sentiment analysis. When considering emotion classification Junaid Akram and others have (Akram and Tahir, 2018) proposed a system to use a lexicon and heuristic based approach to identify emotions in text by using lexicons, negations

as well as emoticons and intensity modifiers. This project is also based on classifying Ekman's 6 emotions. There are few methods tested for emotion identification in text such as keyword spotting, statistical approaches, Latent semantic analysis(LSA), machine learning approaches which uses neural networks and finally handcrafted models, which shows the best results competitively (Liu et al., n.d.). Sven Buechel and others have (Buechel and Hahn, 2017a) created a corpus with over 10k records of English sentences which is identified using dimensional annotations. The three dimensions used are Valence, Arousal and Dominance (VAD) and the dataset is a step forward in the emotion identification as for it focused more on psychologically accurate deduction and most importantly the different effect of readers and writers perspective (bi perspective annotation strategy) as for which is important in scenarios such as this, text messaging. Those two important factors are recognized in this dataset and it is achieved rather than through sentiment analysis (which is to calculate the negative and positive polarity of a sentence) but as mentioned, by the 3-dimensional data. And by the use of this dataset (Buechel and Hahn, 2017b), it was experimented and they have found statistical evidence to show that writers perspective holds better annotation quality comparing with the readers. This experiment also shows that annotation quality of readers and writers perspective depends on the domain or the context which plays an important role when in real life applications.

### **Speech Recognition**

Emotion recognition has been the talk of the town for the last 20 years or more. And with time and new developments, the interest for this new technology which created opportunities in changing human computer interaction grew. And for new research they started using different modalities and

technologies to extract features and to identify human emotions. But as for initiation, some research in the late 90s were mostly based on recognition of emotion through speech. As for gathering a corpus for speech analysis there can be subgroups of acted, non-acted and prompted emotions. Acted emotions are supported and deliberated by a director, but the non-acted emotions are spontaneous and more natural.(Schuller et al., 2011) which is why it is more preferred than acted emotions, since they are not what we come across in actual scenarios. Donna Erickson and Kenji Yoshida along with few others have found that acoustic and articulatory characteristics change from sad spontaneous speech to acted speech, hence there exists a difference.(Erickson et al., 2006) and as for prompted speech we understand that just as with spontaneous speech even though it is more natural it causes confusion and complexes the classification of emotion classes in the database. As for elicited/prompted speech, it could be very dependable on the context of interaction or because of the user's personality. Hence using a dataset with acted speech corpus is much easier and shows better performance in baseline classification and gives a better recognition rate.(Batliner et al., 2005) But as for acted emotions there are some practical issues. As discussed for acted emotions may be highly affected by the actor. And as we are trying to implement these applications in practical situations, acted emotions may be categorized in different classes than natural emotions. This reason for this may be, as discussed by Loic Kessous(Kessous et al., 2010) the effect of a director or, as discussed by Erickson(Erickson et al., 2006) maybe for each actor classifying or expressing their emotions is based on their own experiences or memories. This is discussed by Erickson (Erickson et al., 2006) furthermore that 'natural sad speech and acted speech seem to have similar acoustic features but as for



articulation it is different in terms of lip, jaw and tongue positions'. So, it can be identified that when a person is acting and when the emotions that are genuine it can be different.

### **Facial Recognition**

Humans as for communicating with others have the ability to interpret one's emotions through facial expression. While it is more accurate with the combination on other modularity's such as tone of speech or hand gestures, facial expression is used to express one's feelings or emotions to someone else, also to give feedback as well. Facial expressions are merely a change in facial muscles. But even a slight, subtle change can show a different emotion. As for considering the six basic emotions, they are conveyed through facial expressions in different ways. Such as happiness; through a smile, sadness through a dampened mood or crying (tears), fear facial expression from widening the eyes and pulling back the chin; disgust through wrinkling the nose and curling the upper lip; as for anger it is expressed through frowning or glaring. There are also responses such as sweating and getting red; and finally facial expression for surprise maybe raising the brows, widening the eyes, and opening the mouth. (Physician, n.d., p. 6) When considered from a psychologists perspective they mention that the verbal communication can be modified to more accurate emotion deduction with the support of visual information. (Busso et al., 2004) as for detecting any change in expressions it is usually done by features of local spatial position or displacement of predefined positions (points) or regions of the face. When you consider approaches towards facial recognition a previous effort by psychologists was to use a heuristic static picture-based classification using Facial Action Coding System (FACS) for which is now developed more by other approaches using the computer vision technology which is at peak. Some of the efforts are;

and others have created an algorithm to identify emotions by utilizing the optical flow computation which is used to deidentify rigid and non-rigid facial expression movements. (Yacoob and Davis, 1994) Essa and others have proposed a new system to use probabilistically characterization for facial motion as well as muscle activation using a dataset. This is also an approach using optical flow to couple with geometric and physical features of the facial structure. (Essa and Pentland, 1997)

As for issues we face in emotion recognition through facial expression can be seen through the 4 experiments done by Andrew W. Young and others (Young et al., 1997) for we try to understand if emotions are analyzed as discreet categories which they argue they are. Facial expressions another issue is it is highly affected by culture, for some cultures may express some emotions differently. As for some advantages in face recognition is that, while though speech recognition we cannot identify some of the deceitful expressions of humans, we can sometimes identify them through their facial expressions, such as explained by psychologists is it if a deceitful smile or a fake smile for that matter their eyes would not crinkle, hence with the ability to identify an emotion even from a mere change we can identify if an expressed emotion in fact truthful or not.

### **Gesture Recognition**

While face and speech have a huge impact on emotion recognition, as for face to face communication hand, torso, shoulder and head gestures (upper body) seem to have a huge impact as for classification. (Gunes and Piccardi, 2007, p.) Even though it does not emit a lot of information we can identify some emotions through this modularity. Psychologists have identified the contribution of gesture recognition as for humans express their emotions through different behaviors such as when an

individual is happy they show a relaxed stance; fear as an attempt to hide or flee from the threat or pulling up their hands to cover them, disgust may be turning away from the disgusting object or different physical reactions; as for anger it may be a strong reaction like taking a strong stance or turning away from the angering object, it could also turn in to aggressive behavior from hand gestures such as hitting or throwing objects, which could help us understand the intensity of the emotion as well; surprise maybe physical responses such as jumping back or raising of shoulders and so on. (Physician, n.d.) when experimenting Glowinski and others have identified that there maybe be impulsive reactions as well as fluid reactions,(Glowinski et al., 2008) and 4 types of emotions can be identified through kinematic features recovered from motion cues (velocity of movement, hand displacement). This may help when considering the 3D points that is considered from the head and hands. In this experiment they have identified that unlike facial recognition it is more flexible as it eliminates the appearance of the user which is an advantage of this modularity. As a disadvantage, this modularity is not much used for some applications.

### Bimodal Systems

Even us humans have trouble identifying emotions by just one sensory input. Just seeing another's face sometimes causes confusion in understanding, but if you combine or add more features to it, it becomes somewhat clearer and more accurate. Which is why even for emotion recognition bimodal systems are proposed just as the human sensory system. Bimodal system may have few combinations which maybe, Face- gesture; Face- speech; Gesture speech.

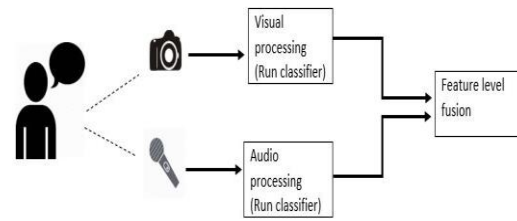

Figure 1. feature level fusion

One of the approaches for these bimodal systems are usually done by, first running it through an automatic classifier on each unimodal modal then combining them (feature level fusion), and finally the decision maker to make bimodal systems. From research the bimodal systems show different percentages of improvement according to the combination of modularity. This also improves the accuracy, for sometimes people try to deceive the system but through other modularity's these maybe detected. Such as even if they sound happy, if the facial expression shows an insincere smile or a slumped shoulder, this could change the deduction of the classification. Which is why psychologists highlight the need of combined sensory detection when it comes to human to human interaction.

As for combinations, there are some concerns such as to which modularity corresponding to a communicative channel should be combined, how they should be fused to achieve human like analyzer and classifier, how a system should handle temporal aspects as well as context information of a user. (Pantic and Rothkrantz, 2003) There are more practical issues when experimenting such as facial and speech are usually considered as independent to each other and, with respect other modularity's we see that gesture recognition even as a unimodal system, it is very much unexplored compared to the other modularity's. But as discussed before it is identified that gesture recognition do give valid accurate information which could increase the classification percentage. And research such as (Kessous et al., 2010) show

us that while speech features show better emotion identification than facial expressions, as for combinations facial and speech the improvement depends on the chosen emotion classifiers as well. But also, their research shows that gesture and facial gives much better improvement than facial and speech combination. When it comes to usability the combination would show much better performance in human computer interaction and the combination maybe according to the application. And furthermore, this paper reviews the multimodal systems, if there is an increment from using two modalities, there exists research done to prove that there is more increment when all 3 or more are combined.

### **Multimodal Systems**

Humans when having any interaction with someone they have their communication channels wide open for input, they hear and see simultaneously. They received tightly coupled input to any scenario from not just one but many different modalities which is why even for human computer interaction multimodal systems are important. As discussed before getting more and more channels and information just makes the classification better and accurate. Which means more the merrier. But when it comes to sensory data fusion we come across doubts as to as if we can, design a system to tightly couple these modalities theoretically and computationally.

As for approaches on how to derive information from these sensors it maybe at data, feature and decision level. When comparing these extractions, data level can only be done for the raw data of the same observation type, also since each of these communicational channels are monitored and collected in different types of sensors data level fusion it is not applicable for human computer interactions. Secondly feature level fusion is more tolerant to noise and sensor failure which is common on most

sensors when considering a practical stance. This approach is better than data level fusion for synchronized, tightly coupled modularity's. But finally, decision level fusion shows the best recognition rate as it is shown that fusion at the end is, at its best for. Also, it may be easier than feature level to find common ground to integrate. Multimodal systems are an approach towards actual resemblance of a human sensory and processing of emotions, this also includes another modularity which is tactile input which may provide more information. Hence as discussed, we can join more and more input channels for this to make the system more accurate with relevance to the application.

### **Emotion Identification Via Text**

When comparing with the other methods text is widely used among new technologies. And with the rapid growth of social media, text has become an important concept that should be researched as for it has growth potential and a lot of applications. A lot of projects have used emotion mining through text, and they have used few different approaches for how they have conducted their project.

The basis of emotion detection from text is to get an input text and reduce it to finding a relation between that specific text and an emotion. This is only based on the text but deep in to considering the authors style, the context of the input text and other attributes, the common methods used cannot cover the accuracy expected. Key word-based detection or key word spotting is one approach used. It marks the key words that have an emotional weight according to the lexicon or a bags of word dictionaries. And by assuming keywords are independent, it excludes the possibility of unambiguity and expression of complicated emotions. Few techniques that is used to implement this is, the use of the WordNet-Affect dictionary which groups words into a set of synonyms

("synsets") which is used to establish affective concepts associates with affective words. ("WordNet Domains," n.d.) WordNet-Affect consists not only emotion labels but also moods, situations eliciting emotions and emotional responses ("WordNet Domains," n.d.). Another resource that is used is SentiWordNet, which is used to mine opinions as one of the following, positive, negativity or objectivity (Esuli and Sebastiani, n.d.). Some approaches have used both the resources together to bring up better performance (Yassine and Hajj, 2010).

Statistical approaches are also used for emotion mining and the Latent Semantic Analysis (LSA) is used by most knowledge-based works. While it is concluded that unless a large corpus is used for training the model, it will not give much accurate or useful output as for the social media and most applications that is used nowadays have less structured data. (Yassine and Hajj, 2010) It is improved by (Canales and Martínez-Barco, 2014) the use of ISEAR dataset and the LSA algorithm.

Machine learning approaches are widely used among the emotion mining as for it is not rule based but has the capacity of learning the data. This shows great potential, as for emotions are sometimes complicated. It is a scientific discipline which creates a model with certain inputs and outputs specific decisions, classifications, or predictions. This approach can be divided in to two as for supervised and unsupervised. Supervised learning approach is based on labelled training data which is then used the training set to validate the outputs. But with the application of emotion mining it would need a large corpus with labeled emotions which works as a disadvantage. But a corpus with twitter messages, which has its emotional intact hashtags has shown great advantage for it is labelled automatically which is better than time consuming labeling and it is used by systems for emotion mining

(Hasan et al., n.d.). Along with supervised learning, unsupervised learning consists of emotion classifying through unlabeled data but through finding a hidden structure. With respect to works that have used unsupervised learning (Strapparava and Valitutti, n.d.), have used WordNet Affect and LSA and have classified the basic Ekman's emotions but also shows that by the use of unsupervised learning it can grasp more than just the 6 Ekman's emotions for it does not depend on existing affect lexicon (Canales and Martínez-Barco, 2014).

Hand crafted models uses more complex systems and deep learning for better recognition of emotions and (Liu et al., n.d.) suggests the use of a novel way of calculating the affective qualities of context and natural language. As for the other mentioned approaches, they all fail at the robust affect classification of small pieces of domain-independent text such as sentences. They understand the importance of emotion change with sentences as it is important in applications. It suggests a large-scale real-world knowledge to tackle the textual affect-sensing problem is a novel approach that addresses many of the robustness and size-of-input issues associated with existing approaches (Liu et al., n.d.). This approach addresses the issues with emotion mining according to context. Hence this context dependent system shows better accuracy for its knowledge for the emotion for by the context or event that deduces the effect by the text which is deducted by the real world database (Yassine and Hajj, 2010).

The above approaches show that emotion mining can be done through many approaches but few issues that comes with the new and upcoming developments that will affect the proposed system would be new trends through social media. The use of emojis has its advantages and disadvantages. Such as overuse of emojis not conveying the direct emotion but causing confusion. But

with emojis there is more impact of text and gains more attention of the emotion that is intact to it. Also, internet slang such as “LOL”, “LMAO” would cause confusion for it is mostly misused in natural dialogs and is also used to convey confusion. But certain technologies such as gifs have added advantages, for it is more direct and has labels of emotions tagged to it.

### Suggested Solution and Methodology

When considering the applicability of the above-mentioned methods for emotion identification few of the solutions are, emotion identification via video/image (facial expressions and gesture movements), speech recognition via voice calls/ video or audio recordings and so on. But among them with the use of social media and chat applications (WhatsApp, Messenger) currently more focus is towards textual communication as for it is much more convenient. Also when considering the applicability of it, it is clear that there are many problems that arises with online chatting systems and social media developments, but among them emotions not being conveyed properly or recognized efficiently by the receiver is a pressing issue. For human computer interactions a system understanding its users’ emotions according to context is an important factor. For if not, the systems actions or output may be inappropriate with the user’s mindset and this cannot be done unless the user directly inputs their mood or emotion, but it can be detected through the user’s text responses, which is why emotion detection through text is important.

Hence with these identified issues this paper proposes a solution to identify emotions of users through text messages, and to create a mobile application as an emotional assistant. By taking advantage of the regularity of communicating via text of the young generation this proposed system will identify the emotion of the users through their text

messages via a chatbot and respond accordingly providing them emotional support when needed. The novelty and aim of it is, not expect the user to directly ask for emotional support but to indirectly identify if they are distressed and provide help or a distraction such as suggesting songs or motivating them.

When considering the methodology for development a convolutional neural network is proposed as to identify the emotion and a mobile application to receive the text input via a custom chatbot as for messages from application such as WhatsApp cannot be retrieved due to privacy issues.

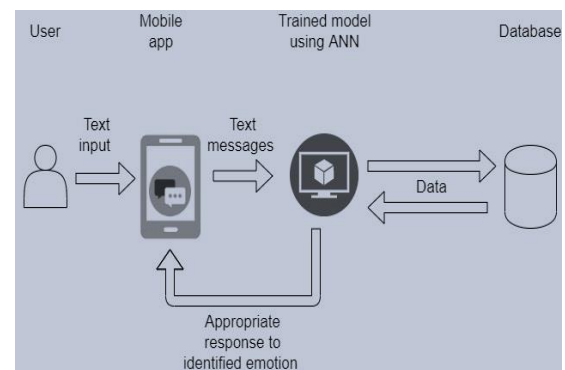

Figure 2. High level architecture of the proposed system

The methodology steps are as follows.

#### A. Data Collection and selecting the data set

This step consists of data collection from many students and identifying the necessity of this project. Data elicitation about the issues they face with and the emotional support they require on a daily basis. Also, there are many datasets available for emotion classifying (Ex : Emobank (Buechel and Hahn, 2017a)). This step would be to find the most appropriate dataset for this project.

#### B. Selecting the appropriate outputs for different scenarios

There are few outputs to be selected as an example if the user is sad then playing a happy and upbeat song they like or show a motivational quote. Likewise, this step is to

find which output is most appropriate for certain situations.

### C. Selecting the attributes to be collected

Initially, the model inputs and what data to be retrieved for future training should be identified and stored in the database.

### D. Designing the model and mobile application

This step considers the designing of the model and selecting which approach is most suitable for the project then designing the model. Also, with the mobile application integration the dialog flow should be managed for real time outputs.

### E. Feature generation and extraction

This step deals with the inconsistent text messages that is taken as input. The abbreviations and social acronyms such as LOL, BRB and emojis are an important factor to be considered as they are widely used among text messages and online chatting systems. Also, with feature generation it is important to gain subjective and objective information through the text message and to understand the context of the text dialog to derive more accurate features and identify emotions more efficiently. Another aspect to consider in this step is other language use in social chatting systems since they are used worldwide and by different counties, they are bound to use different languages in the middle of texts. For an example singlish is a commonly used nonstandard language in Sri Lanka. The preprocessing goes as follows.

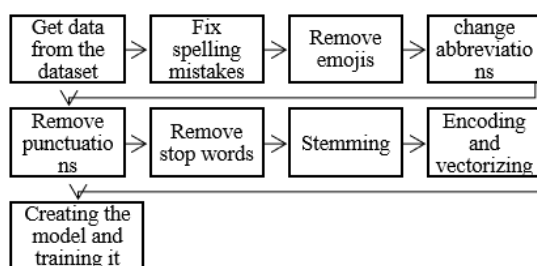

Figure 3. Preprocessing text

### F. Converting model to mobile

By using a tool to convert the model so it can be used in mobile or any other IoT device. As the model will run through a mobile application it is required to convert the created model to mobile.

### G. Test model with validation data and mobile application

Testing the model will be done with the validation data, then testing the application by running a system test (black box testing). For this project it can be experimented using at least 10 people and letting them use the app and by keeping track of its responses. The objective of this project is to reduce stress and to maintain a user's happiness even in sad and upsetting moods, through letting them use this application and during the testing phase it can be validated and the issues and errors can be corrected if necessary.

### Conclusion

In the world of technology not every device or application needs emotion recognition, but for different applications the ability for a computer to identify an emotion of a human may help improve human computer interactions. This review paper identifies the basic modules for emotion recognition which are speech, facial expression, and gesture (upper body). From analyzing the average results all 3 modularity's receive an accuracy of 67.42%, 69.9%, 57.89% respectively. It is identified that speech recognition gives a higher recognition rate in some experiments and even unexplored modules such as gesture adds more potential to emotion recognition. According to the hypothesis we discuss throughout this review that bimodal gives better average overall performance when fused with other modularity's. Such as in speech-face systems it gives an average performance of 74.58%, speech- body 75% and face-body shows best performance at 85.7%. Also, with the effort to resemble a

human sensory system it discusses the multimodal systems which shows a great improvement of 3.3% over the best bimodal systems (Kessous et al., 2010). Hence, we agree with the hypotheses. Also, this review paper discusses the practical and principle issues in each modularity, suggests solutions and other methods. In this paper it discusses the potential research area which is emotion identification via text and the approaches which it can be developed. It is identified rather than a heuristic approach a machine learning or handcrafted model shows better accuracy as for it considers the context and has the ability to adapt with the upcoming trends and social media which is an important factor. Finally, a solution is proposed to create a mobile application to provide emotional support by identifying emotion via text messages using a chatbot. The issues and the opportunities are discussed along with the methodology to follow.

## References

- Akram, J., Tahir, A., 2018. Lexicon and Heuristics Based Approach for Identification of Emotion in Text, in: 2018 International Conference on Frontiers of Information Technology (FIT). Presented at the 2018 International Conference on Frontiers of Information Technology (FIT), IEEE, Islamabad, Pakistan, pp. 293–297. <https://doi.org/10.1109/FIT.2018.00058>
- Atkinson, A.P., Tunstall, M.L., Dittrich, W.H., 2007. Evidence for distinct contributions of form and motion information to the recognition of emotions from body gestures. *Cognition* 104, 59–72. <https://doi.org/10.1016/j.cognition.2006.05.005>
- Batliner, A., Steidl, S., Hacker, C., Noth, E., Niemann, H., 2005. Tales of Tuning --- Prototyping for Automatic Classification of Emotional User States 4.
- Buechel, S., Hahn, U., 2017a. EmoBank: Studying the Impact of Annotation Perspective and Representation Format on Dimensional Emotion Analysis, in: Proceedings of the 15th Conference of the European Chapter of the Association for Computational Linguistics: Volume 2, Short Papers. Presented at the Proceedings of the 15th Conference of the European Chapter of the Association for Computational Linguistics: Volume 2, Short Papers, Association for Computational Linguistics, Valencia, Spain, pp. 578–585. <https://doi.org/10.18653/v1/E17-2092>
- Buechel, S., Hahn, U., 2017b. Readers vs. Writers vs. Texts: Coping with Different Perspectives of Text Understanding in Emotion Annotation, in: Proceedings of the 11th Linguistic Annotation Workshop. Presented at the Proceedings of the 11th Linguistic Annotation Workshop, Association for Computational Linguistics, Valencia, Spain, pp. 1–12. <https://doi.org/10.18653/v1/W17-0801>
- Busso, C., Deng, Z., Yildirim, S., Bulut, M., Lee, C.M., Kazemzadeh, A., Lee, S., Neumann, U., Narayanan, S., 2004. Analysis of emotion recognition using facial expressions, speech and multimodal information, in: Proceedings of the 6th International Conference on Multimodal Interfaces - ICMI '04. Presented at the the 6th international conference, ACM Press, State College, PA, USA, p. 205. <https://doi.org/10.1145/1027933.1027968>
- Canales, L., Martínez-Barco, P., 2014. Emotion Detection from text: A Survey, in: Proceedings of the Workshop on Natural Language Processing in the 5th Information Systems Research Working Days (JISIC). Presented at the Proceedings of the Workshop on Natural Language Processing in the 5th Information Systems Research Working Days (JISIC), Association for Computational Linguistics, Quito, Ecuador, pp. 37–43. <https://doi.org/10.3115/v1/W14-6905>
- Castellano, G., Kessous, L., Caridakis, G., 2008. Emotion Recognition through Multiple Modalities: Face, Body Gesture, Speech, in: Peter, C., Beale, R. (Eds.), *Affect and Emotion in Human-Computer Interaction*. Springer Berlin Heidelberg, Berlin, Heidelberg, pp. 92–103. [https://doi.org/10.1007/978-3-540-85099-1\\_8](https://doi.org/10.1007/978-3-540-85099-1_8)
- Erickson, D., Yoshida, K., Menezes, C., Fujino, A., Mochida, T., Shibuya, Y., 2006. Exploratory Study of Some Acoustic and Articulatory Characteristics

- of Sad Speech. *Phonetica* 63, 1–25. <https://doi.org/10.1159/000091404>
- Essa, I.A., Pentland, A.P., 1997. Coding, analysis, interpretation, and recognition of facial expressions. *IEEE Trans. Pattern Anal. Machine Intell.* 19, 757–763. <https://doi.org/10.1109/34.598232>
- Esuli, A., Sebastiani, F., n.d. SENTIWORDNET: A Publicly Available Lexical Resource for Opinion Mining 6.
- Glowinski, D., Camurri, A., Volpe, G., Dael, N., Scherer, K., 2008. Technique for automatic emotion recognition by body gesture analysis, in: 2008 IEEE Computer Society Conference on Computer Vision and Pattern Recognition Workshops. Presented at the 2008 IEEE Computer Society Conference on Computer Vision and Pattern Recognition Workshops (CVPR Workshops), IEEE, Anchorage, AK, USA, pp. 1–6. <https://doi.org/10.1109/CVPRW.2008.4563173>
- Gunes, H., Piccardi, M., 2007. Bi-modal emotion recognition from expressive face and body gestures. *Journal of Network and Computer Applications* 30, 1334–1345. <https://doi.org/10.1016/j.jnca.2006.09.007>
- Han, K., Yu, D., Tashev, I., n.d. Speech Emotion Recognition Using Deep Neural Network and Extreme Learning Machine 5.
- Hasan, M., Agu, E., Rundensteiner, E., n.d. Using Hashtags as Labels for Supervised Learning of Emotions in Twitter Messages 8.
- Kessous, L., Castellano, G., Caridakis, G., 2010. Multimodal emotion recognition in speech-based interaction using facial expression, body gesture and acoustic analysis. *J Multimodal User Interfaces* 3, 33–48. <https://doi.org/10.1007/s12193-009-0025-5>
- Liu, H., Lieberman, H., Selker, T., n.d. A Model of Textual Affect Sensing using Real-World Knowledge 8.
- Pantic, M., Rothkrantz, L.J.M., 2003. Toward an affect-sensitive multimodal human-computer interaction. *Proc. IEEE* 91, 1370–1390. <https://doi.org/10.1109/JPROC.2003.817122>
- Physician, A.B.-C., n.d. The 6 Types of Basic Emotions and Their Effect on Human Behavior [WWW Document]. Verywell Mind. URL <https://www.verywellmind.com/an-overview-of-the-types-of-emotions-4163976> (accessed 8.30.19).
- Schuller, B., Batliner, A., Steidl, S., Seppi, D., 2011. Recognising realistic emotions and affect in speech: State of the art and lessons learnt from the first challenge. *Speech Communication* 53, 1062–1087. <https://doi.org/10.1016/j.specom.2011.01.011>
- Silva, L.C.D., Ng, P.C., n.d. Bimodal Emotion Recognition 4.
- Strapparava, C., Valitutti, A., n.d. WordNet-Affect: an Affective Extension of WordNet 4.
- WordNet Domains [WWW Document], n.d. URL <http://wndomains.fbk.eu/wnaffect.html> (accessed 2.12.20).
- Yacoob, Davis, 1994. Computing spatio-temporal representations of human faces, in: Proceedings of IEEE Conference on Computer Vision and Pattern Recognition CVPR-94. Presented at the Proceedings of IEEE Conference on Computer Vision and Pattern Recognition, IEEE Comput. Soc. Press, Seattle, WA, USA, pp. 70–75. <https://doi.org/10.1109/CVPR.1994.323812>
- Yassine, M., Hajj, H., 2010. A Framework for Emotion Mining from Text in Online Social Networks, in: 2010 IEEE International Conference on Data Mining Workshops. Presented at the 2010 IEEE International Conference on Data Mining Workshops (ICDMW), IEEE, Sydney, TBD, Australia, pp. 1136–1142. <https://doi.org/10.1109/ICDMW.2010.75>
- Young, A.W., Rowland, D., Calder, A.J., Etcoff, N.L., Seth, A., Perrett, D.I., 1997. Facial expression megamix: Tests of dimensional and category accounts of emotion recognition. *Cognition* 63, 271–313. [https://doi.org/10.1016/S0010-0277\(97\)00003-6](https://doi.org/10.1016/S0010-0277(97)00003-6)
- Yu, F., Chang, E., Xu, Y.-Q., Shum, H.-Y., 2001. Emotion Detection from Speech to Enrich Multimedia Content, in: Shum, H.-Y., Liao, M., Chang, S.-F. (Eds.), *Advances in Multimedia Information Processing — PCM 2001*. Springer Berlin Heidelberg, Berlin, Heidelberg, pp. 550–557. [https://doi.org/10.1007/3-540-45453-5\\_71](https://doi.org/10.1007/3-540-45453-5_71)



## Challenges in investigating Cybercrime in social networks: A Sri Lankan Perspective

K. G. Laksiri Geethal<sup>1</sup>, Kasun De Zoysa<sup>2</sup>, Kenneth Thilakarathna<sup>3#</sup>, Primal Wijesekera<sup>4</sup>  
and Chamath Keppitiyagama<sup>5</sup>

<sup>1</sup>*Sri Lanka Police*

<sup>2,3,5</sup>*University of Colombo School of Computing*

<sup>4</sup>*University of California, Berkeley + ICSI, USA*

#kmt@ucsc.cmb.ac.lk

**Abstract:** With the explosive growth of social networks, the modern society has found itself in the midst of a transformation from pre-social network age to a new world where social networks influence everything from democratic processes such as elections to the mental health of the members of the society. While arguing the net cost and benefits of social networks are out of the scope of this case study, we will argue that social networks have introduced a new threat surface that challenges the current status quo on legal protection and investigative techniques on citizens. These challenges equally affect citizens who request justice and protection, and people who are hiding and avoiding law enforcement.

From the perspective of a developing nation, especially a nation that does not host any technical infrastructure for any leading social network companies, this work presents challenges Sri Lanka could face and discuss their impact on law enforcement investigations. We believe this case study will open up discussions on the proper legal framework to support future investigations.

**Keywords:** Social Networks, Social Media, Law Enforcement, User Privacy, Privacy Expectations, International Jurisdiction.

### Introduction

The evolution of information communication technology and social network applications have made the world smaller and more connected than it used to be. Over the last

decade, social networks took the helm as the most prevalent software in society. We define a social network as any service that offers a community like interaction to users such as Facebook, LinkedIn, TikTok, WhatsApp (Jan H.Kietzmann, et al., 2011). These social networks provide a host of societal benefits that promote freedom of speech, a sense of connectivity, and a place to help each other (Shirky, 2011). Social networks, however, were found to be a source for increased mental health (Rachel L.Frost & Debra J.Rickwood, 2017), cyberbullying (Grace Chi En Kwan & Marko M. Skoric, 2013), a place for vast cyber black market (Paulet, Karen & Pinchot, Jamie, 2012), and sextortion (Mirjana Gavrilovic Nilsson, et al., 2019) – This list is not exhaustive. Among those listed issues, the biggest of all is finding and bringing those responsible for these crimes. Social networks are, by nature, complexed social-techno systems (Jessa Lingel & Adam Golub, 2015), and one downside of that complexity is, it is easy to hide the real identity of people involved in these crimes behind digital avatar (Joshua Brunty & Katherine Helenek, 2012). Such an ability to hide provides users with a criminal instinct to make use of social networks to carry out their unlawful activities (Karabiyik, et al., 2016) (Nova, et al., 2018) (Desmond Upton Patton, et al., 2014).

### Sri Lankan Statistics

According to the Criminal Investigation Department (CID) statistics and Sri Lanka Computer Emergency Readiness Team | Coordination Center (SLCERT|CC), cybercrime activities increase every year. According to the Annual Activity Report – 2019, the percentage of incidents reported to Sri Lanka CERT connected to a social network is consistently high over the last decade (SLCERT|CC, 2019). illustrates the growth of Cybersecurity incidents in social networks comparing with all other incidents reported to SLCERT|CC.

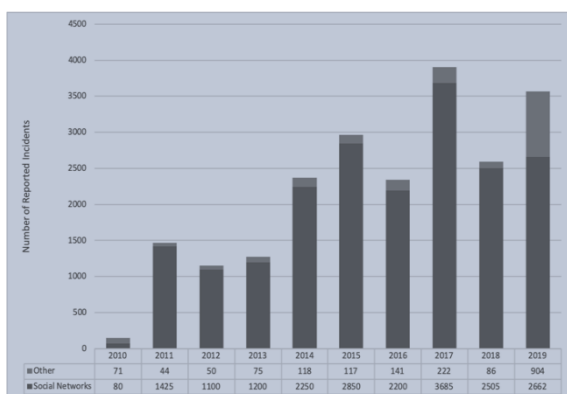

Figure 39: Growth of Cyber-security Incidents reported to SLCERT|CC

contains an extract of the statistics on the number of Cybercrime activities reported to the CID of Sri Lanka with a breakdown of the medium of the crime. Though digital crimes span across several approaches, our focus is on victimization carried out using social network users/ accounts. We analysed censored reports on investigations of selected cases to gather information. Among the incidents analysed, there were cases concerning bullying in cyberspace, cyberstalking, defamation, pornography, Nigerian or “419” Fraud Scheme (Investigation, n.d.), and impersonation.

In the first quarter of 2020, over 87% of 13 million Internet users in Sri Lanka estimated to be using Mobile Broadband connections (TRCSL, 2020). There are around 11 million Internet users having Internet access from almost anywhere.

Table 1: Reported Computer Crimes to CID of Sri Lanka

Year	Categories of Cybercrime			Total
	Social Networks	Unauthorized Access	Emails	
2009	34	2	8	44
2010	61	6	15	82
2011	115	12	34	161
2012	62	11	31	104
2013	23	6	16	45
2014	80	12	22	114
2015	175	15	30	220
2016	170	17	35	222

Reports indicate that there are over 6 million social network users in Sri Lanka as of January 2020, and the number of users increases by year (KEMP, 2020). However, increased use of the social network has also proportionately increased the number of crimes committed.

At this stage of the research we were unable to get the exact number or resolved cases. However, according to discussions with the relevant offices, much of the cases reported to CID were not investigated or resulted in a conviction. Lack of legislative support for social network Cybercrime and Internet Service Providers (ISP) do not keep sufficient amount of details about user activities to derive required evidence were highlighted during the interviews.

### Legal Background

A crime initiated over the social network needs to accompany a digital device with computational power such as a mobile phone, laptop computer, or tablet computer. The device may have been used in many ways to commit the crime. Instead of reaching the victim in person, the victim’s computer or mobile device would be an alternative target. An attack may be initiated by merely making the victim open a spreadsheet application where even an anti-virus program would not identify the file to be evil. Legislation and legal provisioning have already been established in Sri Lanka in provisioning the required legislative protection for citizens victimizing from such

crimes through “Computer Crime Act, No. 24 of 2007” (PARLIAMENT OF THE DEMOCRATIC SOCIALIST REPUBLIC OF SRI LANKA, 2007). It defines and describes what is considered an offense, how compensation is awarded for loss or damage due to an offense, provisions concerning the investigations, and procedures for a “Computer crime.” Further, in the recent past, there have been initiatives to accede with the Budapest Cybercrime Convention of the Council of Europe in resolving limitations such as multi-jurisdictional investigations (Europe, 2001). It was also identified that there are multiple Acts related to the Computer Crime Act, No. 24 of 2007, such as Code of Criminal Procedure Act, No. 15 of 1979, Extradition Law, No. 8 of 1977, Payment Devices Frauds Act, No. 30 of 2006, Obscene Publication Act. No. 22 of 1983, Penal Code No. 02 of 1883, Electronic Transactions Act No. 19 of 2006, Information and Communication Technology Act No. 27 of 2003, Intellectual Property Act No. 36 of 2003, and Payment and Settlement Systems Act No. 28 of 2005.

### **Investigative Challenges**

Here we list different categories of challenges criminal investigators could face.

#### **A. Multiple Jurisdiction Challenges**

According to CID, gathering valid evidence against accused from social networks is challenging. There is literature discussing the possibility of extracting evidence from social networks (Kathryn C. Seigfried-Spellar & Sean C. Leshney, 2016). However, with the controls in place to protect social network user accounts, the amount of data that can be extracted is limited (SON, 2012). Following data misuse scandals reported recently, many social network service providers further restricted access to the information making the data extraction much more limited (Archibong, 2018). While it is hard to speculate, tighter restrictions are imposed

for user protection or as a marketing tactic to count fear of government surveillance (Scott, 2017). In the recent past, tech companies like Apple, Google, Microsoft, and Facebook have used denying government requests for data as a media circus to portray themselves as guardians of user data (Feiner, 2020). Answering the question of who is being more responsible for the greater good of the society remains tricky; in the meantime, this will present a more significant threat to a proper investigation of many important legal cases. As a result, it will hinder prosecuting criminals.

Unsupportive social networks are a global threat to law enforcement. However, countries like Sri Lanka have a more severe challenge in pursuing criminal investigations – under whose jurisdiction these big tech companies fall. In the infamous case of unveiling the “Silk Road” underworld marketplace (Bearman & Hanuka, 2015), the reporting of the case highlighted multi-jurisdiction issues. With tech companies situated in other countries under different laws and regulations, countries such as Sri Lanka faces the daunting task of getting their requests processed by those companies. Given the social-economic status of Sri Lanka, the question is, what incentivizes these tech companies to comply with the Government of Sri Lanka? So far, we have seen Facebook keenly helping Sri Lanka it tackling the spread of fake news, although Facebook was not complying initially (Reporter UCA News, 2020). However, no public records are available on government requests to Facebook concerning criminal investigations.

#### **B. Legal Challenges**

Another aspect that comes with multi-jurisdiction is how global laws on data protection and privacy affect criminal investigation in countries like Sri Lanka. Most of these big tech companies have data servers span across the world, and most of

the latest wave privacy regulations, such as General Data Protection Regulation (GDPR), have relied on the location of the data server in question (Catherine Jasserand, 2018). However, it still an open question of how the said purpose of data collection will come into play when companies are to comply with government requests. For example, can a third-party service such as Facebook, who collect logged IPs, and locations for advertising purposes, share such information for a criminal investigation? Because the later is different from the original data collection purpose. GDPR is forcing everyone to be upfront about their data collection, and respective purposes and such purposes never include sharing their user data with governments. Such an acknowledgment will negatively impact the tech firm's trust. Given that GDPR is the first global-scale privacy regulation, most global tech companies are adopting to avoid fines. We envision GDPR will come into play in many Sri Lankan investigations as well.

Another aspect of GDPR that is likely to affect criminal investigations in Sri Lanka is the "*right to be forgotten*" directive in GDPR (Zaman & Hassani, 2019). Under GDPR, users can ask tech companies to delete any data related to the given user. Such requests could potentially delete important evidence related to a criminal investigation. While the probability of that happening is still theoretical, it is crucial to be aware of these situations that could roadblock an investigation.

#### C. Technical Challenges

In a social network, each user has a perceived identity (or avatars). Criminals or even average citizens do not have real information on social networks (Krombholz, Katharina, et al., 2012). Criminals do that to avoid legal action, and others do that for privacy reasons. Identifying real people behind social network avatars (de-anonymizing) is why people are still looking for a solution

(Narayanan & Shmatikov, 2009). Identifying the relationship between two avatars from different social networks does not reveal a person's real identity who may be involved in the act of crime. Another technical challenge along anonymization is the dark web and related technologies (Jardine, 2015) (David Goldschlag, et al., 1999). By nature, these techniques are designed to hide identities and other information that could pinpoint a real person. Investigating "silk road," such technologies are shown to be a significant technical challenge even to nations such as the US, Canada, Europe with vast technical tools at disposal (Joshuah Bearman & Tomer Hanuka, 2015). Such techniques have the capability of completely derailing an ongoing investigation. We believe that outside of legal challenges, the dark web and related technologies pose the biggest threat.

#### D. Privacy Challenges

Privacy and data protection play a prominent role in mitigating risks and achieving trust for any organization, even for a government. However, according to the United Nations Conference on Trade and Development (UNCTAD) 2019, Sri Lanka does not have any legislation on Privacy and Data Protection (Senaratne, 2020) (UNCTD, n.d.).

Especially the children in this modern society dealing in cyberspace create a dangerous situation for themselves. In Sri Lanka, a schoolgirl committed suicide because of a relationship she developed within the cyberspace. She took her life because she could not bear the mental agony she underwent. According to the incidents reported to the Child Protection Authority, there are incidents where school girls became mothers. Consequently, some went abroad because they could not face the society. This situation has created a great danger within Sri Lankan society. Children's Online Privacy Protection Rule (COPPA) in the US is one of the most stringent privacy laws safeguarding children online (Szoka,

Berin & Thierer, Adam, 2009), and GDPR also has provisions for kids. We present children's privacy as a use case where a lack of regulations might block investigators from the necessary tools to go after criminals. Nowadays, criminals use every possible tool they possess to exploit victims, and so should law enforcement possess every tool they can use.

#### E. Open Source Intelligence

One of the biggest advantage on social network is the elevated role of open source intelligence (OSI). Open source intelligence focuses on gathering evidence based on publicly available data mainly data available in social networks. Organizations such as Bellingcat performs crucial investigations for both public safety and for legal cases crowdsourcing evidence collection based on data available online. The effectiveness of OSI in a criminal investigation relies heavily on the nature of investigation.

While OSI will not be a tool for every social network investigation, it is important to understand availability of tools such as OSI for evidence collection. This is even more important as a low cost solution for countries like Sri Lanka. If the data is publicly available, accessing such data for an investigation will not violate user privacy.

#### Discussion

Convicting a person requires an entity that can be produced to the court of law. The study was carried out to identify the challenges of mapping a virtual person to a real person produced to the court of law. This mapping requires the information from multiple sources such as social network service providers, ISPs, telecommunication service providers, etc.. For this study, the most vital information to map a virtual person to a real person lies with the social network service provider. However, every case we studied, the social network service provider is from outside the country and

governed by different jurisdictions. Additionally, they are abiding by the privacy policies and laws that are in place to build trust and minimize their users' risk. Therefore, retrieving such information is an enormous process. This may be one of the reasons for investigations of some cases that have to be put on hold for years. The privacy laws intended to protect people have provided hiding grounds to malicious users at least by making the investigation more difficult or sometimes practically infeasible due to transnational jurisdictions.

Even after obtaining the information from the social network service provider, the information should be correlated with other supporting digital evidence from the rest of the information sources. One of the main limitations that has been encountered in investigations was information sources such as ISPs do not keep the user activity information with sufficient amount of details. Further, lack of policies on information classification lead to shorter retention period for information that are important for Cybercrime investigations.

In a situation where Internet communication anonymizers (Jardine, 2015) (David Goldschlag, et al., 1999) have been used by the suspect, the investigation process becomes more challenging. Much research has been carried out on de-anonymize social networks using different approaches. Most of the research has not focused on de-anonymization targeted for a particular avatar, which is the practical need in conducting those above digital forensic investigations.

Employing social engineering methods on suspects to identify their identity has been successful for a considerable amount of cases. Improved skills and tools would have served better for their endeavors. Conducting an investigation is quite different from hacking into a system—this further narrow down techniques and approaches

that can be employed for digital forensic investigations.

Although our work focuses on proceeding criminal investigations on social networks, the other side of this topic is user privacy. Users are globally wary of the reach of the government into their personal life, and with a fully connected digital infrastructure, their concerns have become a reality. While there is no black-&-white answer to this concern, the most acceptable answer is to create a dialog and let different stakeholders voice their concerns.

In the Sri Lankan context, consumers lack a proper legal framework to protect themselves against unlawful government reach; however, even for a legitimate criminal investigation, law enforcement might lack tools. The future of this dialog should focus on low-cost techniques that suit countries like Sri Lanka. In the meantime, proper steps should be taken to protect consumer privacy. Such laws are not meant not to impede any legal consumer protections but to increase consumer confidence, protect consumers from other malicious users roaming in social networks.

Criminal investigations on social networks are still young in many ways. However, given the statistics shown above, the crime rate involving social networks have gained space and as a nation and for the sake of law enforcement, proper tools and legal protection should be available for the betterment of the society.

### **Evidence Based Strategy**

Regardless of the paper's challenges, as a nation, we need a strategy on how to cope up with cybersecurity challenges. The challenges we mention are low scale issues likely related to individual cases, but not far from the future, we need to tackle organized state-sponsored cyber intrusions that need a more robust and collective response.

Whether it is a national strategy to deter nation-states or a strategy on preventing cyber criminal activities, we need an evidence-based approach. As a nation, we need to have data and monitor and understand patterns across criminal activities across Sri Lanka. An evidence-based approach will inform law enforcement on criminal activity trends to be better prepared with tools and techniques.

A well-defined strategy involved training law enforcement personnel, introducing a framework on using proper tools and techniques so that even a law enforcement officer in remote villages know how to do it without depending on high tech tools only available in Colombo. Planning and deciding what to train and the nature of tools and techniques that we should be adapting should be entirely dependent on current situations, past data, and future trends; hence, it should be based on data collected and processed across Sri Lanka.

### **Conclusion**

We believe it is high time that necessary stakeholders will amend the current regulations to comply with the latest threat landscape and technologies. We believe the lack of proper tools and legal frameworks will make investigations harder and work as an incentive for criminals. We believe that this work will provide the necessary context for a much need dialog to discuss the future of the legal framework, how to safeguard people's privacy, and, most importantly, how to speed up investigations with proper tools.

### **References**

- Archibong, I., 2018. *A Platform Update*. [Online] Available at: <https://about.fb.com/news/2018/07/a-platform-update/> [Accessed 22 07 2020].
- Bearman, J. & Hanuka, T., 2015. *The Untold Story of Silk Road, Part 1*. [Online] Available at:

<https://www.wired.com/2015/04/silk-road-1/>  
[Accessed 23 July 2020].

Catherine Jasserand, 2018. Subsequent Use of GDPR Data for a Law Enforcement Purpose: The Forgotten Principle of Purpose Limitation?. *European Data Protection Law Review*, 4(2), pp. 152-167.

David Goldschlag, Michael Reed & Paul Syverson, 1999. Onion routing. *Communications of the ACM*, 42(2).

Desmond Upton Patton, et al., 2014. Social media as a vector for youth violence: A review of the literature. *Computers in Human Behavior*, Volume 35, pp. 548 - 553.

Europe, C. o., 2001. *Convention on Cybercrime*. [Online] Available at: <https://www.coe.int/en/web/cybercrime/the-budapest-convention> [Accessed 22 07 2020].

Feiner, L., 2020. *Apple refuses government's request to unlock Pensacola shooting suspect's iPhones*. [Online] Available at: <https://www.cnn.com/2020/01/14/apple-refuses-barr-request-to-unlock-pensacola-shooters-iphones.html> [Accessed 23 07 2020].

Grace Chi En Kwan & Marko M. Skoric, 2013. Facebook bullying: An extension of battles in school. *Computers in Human Behavior*, 29(1), pp. 16-25.

Investigation, F. B. o., n.d. *Nigerian Letter or "419" Fraud*. [Online] Available at: <https://www.fbi.gov/scams-and-safety/common-scams-and-crimes/nigerian-letter-or-419-fraud> [Accessed 24 07 2020].

Jan H.Kietzmann, Kristopher Hermkens, Ian P.McCarthy & Bruno S.Silvestre, 2011. Social media? Get serious! Understanding the functional building blocks of social media. *Business Horizons*, 54(3), pp. 241-251.

Jardine, E., 2015. *The Dark Web Dilemma: Tor, Anonymity and Online Policing*. Virginia Tech, s.n.

Jessa Lingel & Adam Golub, 2015. In face on Facebook: Brooklyn's drag community and

sociotechnical practices of online communication.. *Journal of Computer-Mediated Communication*, 20(5), pp. 536-553.

Joshua Brunty & Katherine Helenek, 2012. *Social Media Investigation for Law Enforcement*. s.l.:Routledge.

Joshuah Bearman & Tomer Hanuka, 2015. *The Untold Story of Silk Road, Part 1*. [Online] Available at: <https://www.wired.com/2015/04/silk-road-1/> [Accessed 23 07 2020].

Karabiyik, U. et al., 2016. A Survey of Social Network Forensics. *Journal of Digital Forensics, Security and Law (JDFSL)*, Volume 11, pp. 55-128.

Kathryn C. Seigfried-Spellar & Sean C. Leshney, 2016. Chapter 4 - The intersection between social media, crime, and digital forensics: #WhoDunIt?. In: J. Sammons, ed. *Digital Forensics*. Boston: Syngress, pp. 59 - 67.

KEMP, S., 2020. *DIGITAL 2020: SRI LANKA*. [Online] Available at: <https://datareportal.com/reports/digital-2020-sri-lanka> [Accessed 22 07 2020].

Krombholz, Katharina, Merkl, Dieter & Weippel, Edgar, 2012. Fake identities in social media: A case study on the sustainability of the Facebook business model. *Journal of Service Science Research*, Volume 4.

Mirjana Gavrilovic Nilsson, Kalliopi Tzani Pepelasi, Maria Ioannou & David Lester, 2019. Understanding the link between Sextortion and Suicide. *International Journal of Cyber Criminology*, 13(1), pp. 55-69.

Narayanan, A. & Shmatikov, V., 2009. *De-anonymizing Social Networks*. Washington, DC, USA, IEEE Computer Society.

Nova, F. F. et al., 2018. *Silenced Voices: Understanding Sexual Harassment on Anonymous Social Media Among Bangladeshi People*. s.l., ACM, p. pages 209-212.

PARLIAMENT OF THE DEMOCRATIC SOCIALIST REPUBLIC OF SRI LANKA, 2007. *COMPUTER CRIME ACT, No. 24 OF 2007*, Colombo: THE GOVERNMENT PUBLICATIONS BUREAU.

Paullet, Karen & Pinchot, Jamie, 2012. *Cybercrime: The Unintentional Effects of Oversharing Information on Facebook*. s.l., s.n.

Rachel L.Frost & Debra J.Rickwood, 2017. A systematic review of the mental health outcomes associated with Facebook use. *Computers in Human Behavior*, Volume 76, pp. 576-600.

Reporter UCA News, 2020. *Facebook sorry for role in Sri Lankan riots*. [Online] Available at: <https://www.ucanews.com/news/facebook-sorry-for-role-in-sri-lankan-riots/88037> [Accessed 23 07 2020].

Scott, J. D., 2017. Social Media and Government Surveillance: The Case for Better Privacy Protections for Our Newest Public Space. *Journal of Business & Technology Law*, 12(2).

Senaratne, N., 2020. *The Growing Need for Privacy and Data Protection in Sri Lanka*. [Online] Available at: <https://www.ips.lk/talkingeconomics/2020/01/13/the-growing-need-for-privacy-and-data-protection-in-sri-lanka/> [Accessed 23 07 2020].

Shirky, C., 2011. The Political Power of Social Media: Technology, the Public Sphere, and Political Change. *Foreign Affairs*, 90(1), pp. 28-41.

SLCERT|CC, 2019. *Annual Activity Report 2019*, Colombo: Sri Lanka Computer Emergency Readiness Team | Co-ordination Center.

SON, J., 2012. *Social Network Forensics: Evidence Extraction Tool Capabilities*. AUT University, New Zealand: Design and Creative Technologies in the school of Computing and Mathematical Sciences.

Szoka, Berin & Thierer, Adam, 2009. COPPA 2.0: The New Battle Over Privacy, Age Verification, Online Safety & Free Speech. *SSRN Electronic Journal*.

TRCSL, 2020. *Statistics*, Colombo: Telecommunications Regulatory Commission of Sri Lanka.

UNCTD, n.d. *Data Protection and Privacy Legislation Worldwide*. [Online] Available at: [https://unctad.org/en/Pages/DTL/STI\\_and\\_ICT\\_s/ICT4D-Legislation/eCom-Data-Protection-](https://unctad.org/en/Pages/DTL/STI_and_ICT_s/ICT4D-Legislation/eCom-Data-Protection-)

Laws.aspx  
[Accessed 23 07 2020].

Zaman, R. & Hassani, M., 2019. *Process mining meets GDPR compliance: the right to be forgotten as a use case*. Aachen, Germany, s.n.

## Acknowledgment

We would like to show our gratitude to Criminal Investigation Department of Sri Lanka Police for their cooperation during the research study.

## Author Biographies



Laksiri Geethal is a Senior Superintendent of Police and Director Police Tourist Division. He obtained his MSc. in Information Security from University of Colombo School of Computing. He has a postgraduate diploma in Criminology and Criminal Justice from University of Sri Jayawardhanapura and trained on Darknet and Darkweb investigations at Interpol Training Center, Singapore. He is a lecturer in Police Academy (Cybercrime and cybersecurity). His research interests include Digital Forensics, Cybersecurity and Law, Criminal Investigations.



Kasun De Zoysa is a senior lecturer at University of Colombo School of Computing (UCSC). He obtained his Ph.D from the Stockholm University, Sweden. He is an advisor to the Sustainable Computing Research Group and Centre for Digital Forensic attached to UCSC. He teaches Digital Forensics, Cryptography, Cybersecurity, Information Security at UCSC. He conducts lectures and trainings on Information Security both locally and internationally. His research interests include Digital Forensics, Cybersecurity, Cryptographic Systems, Information Security.





Kenneth Thilakarathna is a lecturer at University of Colombo School of Computing (UCSC). He obtained his M.Phil from UCSC. He is an advisor to the Sustainable Computing

Research Group. He teaches Network Security, Digital Forensics, and Security in Governance at UCSC. His research interests include Digital Forensics, Cybersecurity, Network Security, and Security in Governance.



Primal Wijsekera is a research scientist affiliated with International Computer Science Institute and Electrical Engineering

and Computer Science Department in University of California, Berkeley. He obtained his Ph.D from the University of British Columbia. He is an advisor for

Sustainable Computing Research Group. He teaches Mobile Forensics and Privacy in the masters programs at UCSC. His research interests include Mobile Forensics, Cybersecurity, Privacy, Fake News, Understanding Hackers and Permission systems in general.



Chamath Keppitiyagama is a senior lecturer at the University of Colombo School of Computing (UCSC). He obtained his

Ph.D from the University of British Columbia. He is an advisor to the Sustainable Computing Research Group. He teaches Digital Forensics, Cryptography, Operating Systems and Computer Networks at UCSC. His research interests include Cryptography, Computer Networks, Distributed Systems, and Operating Systems.

## A Study on the Ayurveda Plant Recognition for Remedial Medications Using Image Processing Techniques

K. Anuradha#, D.P.M. Lakshan and R.P.S. Kathriarachchi

*Faculty of Computing, General Sir John Kotelawala Defence University, Ratmalana, Sri Lanka*  
#anuradhakurunayaka@gmail.com

**Abstract:** Plants are considered an essential part of our ecosystem and Sri Lanka has a long history of using plants as a source of medicines in Ayurveda. In addition to some herbaceous plants serving as a food source, have medicinal values. In the Ayurveda medicinal industry, it is very important to identify the correct herbs that help in the preparation of remedial medicines. The identification of these suitable herbaceous plants is often done by skilled specialists. However the problem is since identification is based on human cognition, it can lead to misjudgment. So it a waste that humankind couldn't use the herbal power of remedial medications. To address this question the paper proposes a simple and effectual methodology for identification of Ayurveda's herbaria, using mobile devices in the android platform by implementing image processing techniques. The main characteristics required to identify a medicinal herb are the shape, color, and texture of the leaf. The color and texture of the leaf cover vital parameters that are unique to a particular plant. Preprocessing, feature extraction, and classification are the three major phases in the suggested methodology. In order to train neural networks, images of herbal plant leaves were captured under the supervision of an Ayurveda doctor. For all the images backgrounds are removed and resized before applying classification techniques. According to the methodology, the leaf images are trained and the result can be shown through the mobile application. The study got 94% of accuracy for the proposed methodology.

**Keywords:** Ayurveda herbs, Image processing, Feature Extraction

### Introduction

Ayurveda is an ancient form of medicine that specialized in India and dates back to the Vedic period, roughly 5,000 years ago. Ayurveda is considered to be the oldest healing science in medicine. Ayurveda in Sanskrit means "The Science of Life". Ayurveda is widely used in its land and around the world, despite being subdued to living abroad for many years and also especially in Sri Lanka. It has still followed by countless people as it is purely natural and has no side effects. It is much applicable from ancient times to this most modern time because of its power to cure chronic

diseases. It inspires the use of herbal and non-toxic plants. It is known that about 8000 plants have medicinal properties. The principles built on this Ayurveda system are always true for all ages and can be easily followed from generation to generation.

The plants around us play a huge role in shaping the ecosystem. Some of the food we can eat is above or below the ground and there are a variety of plants that have been found to be used in medicine called Ayurveda. The main ingredients of Ayurveda medicines are plant leaves, roots, bark, fruits, seeds, etc. In the past, Ayurveda physicians themselves selected herbs and prepared medicines for patients. In those days, people were aware of the remedial values and uses of the medicinal plants found in their surrounding environment. But many people in this new generation do not have any

knowledge about these herbs. According to Ayurveda, every plant on earth has some medicinal value, so it is important to protect the plant and identify its medicinal values. The existence of our planet's ecology is impossible without plants. So, herbals are a great advantage that gains from plants. On the other hand, studies have proved that consuming so much of allopathic medicines may lead to side effects as it carries out many chemical reactions within the body. A general fact about western medicine is that once it is taken, western medicine requires taking another medicine to cure the side effects which has happened due to the previous medicine. In general, the process of consuming medicines will not end. Allopathic treatments are inevitable to Treat the Symptoms of a disease whereas Ayurveda treats the root of the disease.

These plants are usually collected by tribal people who are not professionally trained in the task of identifying the correct plants. Today the plants are collected by women and children from the forest areas. They do not have professional training to identify the correct medicinal plants. Production units often get the wrong or substitute medicinal plants. Besides, there is confusion over changes in local names. Some plants come in dry form, which makes manual recognition a more difficult matter. Misuse of medicinal plants makes Ayurveda medicine ineffective. It can also produce an unexpected side effect. For this purpose, creating and maintain a plant database is a critical step towards the protection of the earth's biosphere. There are countless species around the world. To handle such volumes of data, improvement of a brisk and effective system for storing and maintain plant data for later recognition is required.

Everything except the leaf is three-dimensional objects and increases the complexity of the analysis by computer. However, plant leaves are 2D objects and

carry sufficient information to identify the plant. The leaves can be easily collected, and images can be taken using expensive digital cameras, cell phones, or document scanners. As the leaves grow, they acquire a specific color, texture, and shape, but these differences are relatively insignificant. Leaf-based plant identification depends on specific descriptions and feature vector extraction. The feature vectors of the training samples are then compared with the feature vectors of the test sample to find the degree of similarity using an appropriate classifier. Pattern recognition tasks performed specifically on leaves are called leaf recognition. Leaf pictures could be classified as "identified" as well as "not identified" by evaluating leaf with images stored in the database. One can send an image or picture of a recognizable leaf to a computer, and the computer can identify the leaf if its data is in the database using a texture extraction method or other image processing methods. The input for any image processing method can be an image, photos, or frames in a video. The output can be another image or set of characteristics of an input image. Pictures represented in visual information are called images.

### **Background and Motivation**

Because of the increased commercialization of the Ayurveda sector, several issues regarding the raw material quality used for their preparation need to be focused. The Ayurveda plants are usually collected by tribal masses that are not professionally trained in the work of identifying the correct plants. Even the manufacturing units, sometimes, receive improper or substituted medicinal plants. Most of these manufacturing units do not have proper quality control mechanisms that can screen these plants. It is difficult to identify a plant species through a photograph because of its complex three-dimensional structure which cannot be captured through cameras, but it is

possible if the leaf can be identified. Luckily most of the leaves are two-dimensional and it is possible to automate the identification of a plant species through its leaf morphology. In order to invent an automatic recognition system of remedial medications, it is necessary that medicinal plants be identified by common people. So the motivation of this study is to take the leverage of technology in identifying and classifying the plants.

## Literature Review

### A. Problem

By conducting an interview, researches, questionnaires, and case studies from with the researches botanists Ayurveda doctors and medical students, in the sample local areas of Matara and Galle it was proofed that a system for recognition of Ayurveda leaves would be a great help in the arena of improvement of the remedial medications in Sri Lanka with the busy schedules of the lifestyle of the people.

### B. Previous Researches

(Dhingra et al., 2018) In this paper, an identification system has been developed using imagery of foliage. A mobile app was also developed to allow a user to take pictures of leaves and upload them to a server. To obtain a potential match, the client performs pre-processing and feature extraction techniques on the image before comparing the information extracted from this image with the information in the database.

(Gwo and Wei, 2013) This article proposes a simple and efficient method for classifying Ayurveda plants using digital image processing and machine vision technology.

The three main stages of the proposed methodology are preprocessing feature extraction, and classification. Many of these methods use a combination of many parameters, such as color, shape, and texture. The proposed method was tested

with 208 sample leaflets of 26 different species and in many cases a positive response.

(Venkataraman and Mangayarkarasi, 2016) Identifying herbal remedies for home remedies for the general public will be helpful. The purpose of this project is to provide a free app for everyone and the most common mobile platform, Android, and can be used for personal or research and learning purposes. The detection is done by a texture extraction algorithm called the gray-level co-occurrence matrix (GLCM). A working prototype of the project was made and tested with samples that showed satisfactory results.

(Munisami et al., 2015) A vision-based approach is used to create an automated system that identifies plants and values their values. This article discusses how to create a feature set that is an important step in identifying any species.

(Pramanik et al., 2010) The most reliable solution to overcome the botanical taxonomy gap, which receives considerable attention from both the botanical and computer community, is the identification of automated plant images. The first mobile device was acquired by the BJFU100 dataset, which contains 10,000 images of 100 plant species, providing data pillars for further plant identification studies. The proposed model ResNet26 results show an accuracy of 91.78% in the test set, indicating that the deep environment is a good technology for large-scale classification of the natural environment.

(Mzoughi et al., 2013) This paper has described a working computer vision system that helps identify plant species. When a user takes an isolated leaf on an empty background, the system takes the shape of the leaf and fits it into the green shape of the known species. In just a few seconds, the

system displays the highest matching species with text descriptions and additional images.

(Belhumeur et al., 2008) This study proposes a feature extraction method for green contours, which describes the lines between the centroid and each contour point on an image. A long histogram is made to represent the distal distribution of the leaf contour. Then, a statistical model is used to calculate the fit of the template and the query form.

(Sun et al., 2017) This paper explores the vectors and morphological features of the front and back of a green leaf. Scanned images of the front and back of the most widely used Ayurvedic medicinal plant leaves create a database of plant herbal leaves. The leaves are classically based on a unique combination of elements. Up to 99% detection rates have been obtained when testing a wide range of classifiers.

(Kumar et al., 2017) The article has addressed a comprehensive study of disease detection and leaf classification using image processing techniques. In addition to unequal processing times, it includes a specialty in the field of phytopathology. Therefore, image processing has been applied to identify plant diseases. A comprehensive discussion of disease detection and classification performance is presented. The proposed method is based on the local representation of leaf fragments. Semi-based decomposition is defined and is generally used by botanical. A global image query is a collection of partial sub-image queries. Experiments on leaf imagery in the real world.

(Br, 2016) This approach is useful in the classification of MLPs, which helps to identify different plants based on their botanical or genetic characteristics. Since the leaf structure of different crops varies, the replicas of the present work clearly show the specific characteristics of each variety.

## Methodology

### A. Requirement analysis

In Sri Lanka, there are no standard databases of Ayurveda medicinal plant leaves which is available for conducting the research experiments. Leaf images set of medicinal plants were collected from a private botanical garden. 15 leaves were collected in a random style from 30 different plant species used for remedial medications. The remedial leaves were collected from their natural habitat and they were selected in quite random.

Scanned images are obtained in high resolution (1,200 dpi) and RGB format. Images were rendered in the TIFF format to maintain the original quality of the images. Live leaves were collected here. Captured images were taken with a high-quality camera. And also a few leaf images were taken with cell phones. When capturing images, both still images and videos of herbaceous plants were collected. And then they are converted to images using a video editing software

### B. Design and Implementation

The methodology for identifying Ayurveda leaf samples consists of five steps namely, Image acquisition, pre-processing, feature extraction, classification techniques, and testing. The proposed system will focus on identifying herbs especially Ayurveda plants. Image processing techniques will be used to identify the plant species and it would be identified based on leaf image processing.

When a leaf image of a specific plant is fed into the system and the system will pre-process the image to diminish the noise present in it and to get grayscale, binary, and edge for future extraction. In the feature extraction phase, arithmetic means on a color image, the standard deviation on color as well as, Entropy on grayscale image, Solidity, Extent, Eccentricity, and Equivalent

diameter would be calculated. After the feature extraction phase, the leaf factor of the particular leaf would be calculated using a suitable machine learning algorithm like Weka (Weka is a collection of different machine learning algorithms that are written in Java and it is open-source software) And calculations on that different samples of that plant type would consider and the average leaf factor would be calculated which is unique for a specific leaf type and its value would be stored in the database. When a new leaf is fed into the system for recognition, the leaf factor of that particular leaf would be calculated, and it would compare with the leaf factor which is stored in the database and the most matching leaf would be returned as the output.

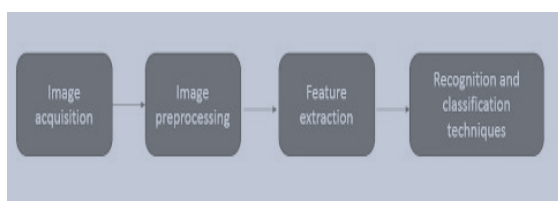

Figure 1. Steps in Image Processing  
Source:(Amara et al., n.d.)

### A. Image Acquisition

Datasets are collected in such a way that leaves are captured against a white background using a digital camera or through a scanner. The experiments would be carried over the datasets collected.

### B. Pre-Processing

The main purpose of pre-processing the data is to enhance the visual appearance of the image and to improve the manipulation of datasets. This is achieved by removing unwanted noise, reconstructing the image, enhancing its quality, etc.

Pre-processing the image is an important step as it increases the probability of getting the desired output in the future steps of image processing. The input image is converted to grayscale and the binary image to keep the pixel values as either 1 or 0, so as

the feature extraction operations can be made simpler as well as the image gets stored as lower sized binary images. The input image is smoothed to reduce the noise in the image. Smoothing reduces the number of pixels in the image and it helps in detecting the edges in an image.

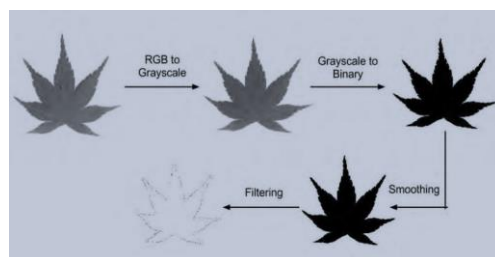

Figure 2. Steps in Pre-processing  
Source: ("Preprocessing steps performed on an Acer Palmatum leaf image. | Download Scientific Diagram," n.d.)

### C. Feature Extraction

Image processing techniques are used to extract a set of features that characterize or represent the image. The values of the extracted features represent the information in the image and those values are as Mean, Standard Deviation, Solidity, Extent, Eccentricity, and Equivalent diameter.

$$\text{Equivalent diameter} = \sqrt{\frac{4 * \text{area}}{\pi}}$$

Convex area specifies the total number of white pixels that are present in the Convex Image. A convex image is a binary image that specifies the smallest convex polygon that contains the region in which all the pixels are filled in within the polygon. Solidity can be calculated as;

$$\text{Solidity} = \frac{\text{Convex area}}{\text{Original area}}$$

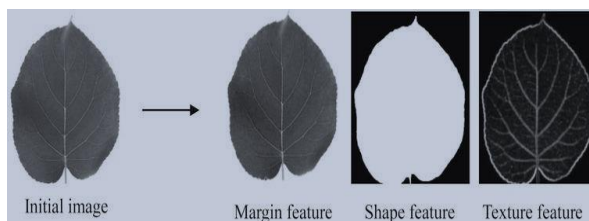

Figure 3. Image texture

Source: ("Preprocessing steps of leaf images: a) original image; b) greyscale... | Download Scientific Diagram," n.d.)

Eccentricity is a characteristic of a conic section. It can be calculated as,

$$\text{Eccentricity} = \sqrt{1 - \left( \frac{\text{Minor axis length}^2}{\text{Major axis length}^2} \right)}$$

Extent is the ratio of the total number of pixels in the region to the number of pixels in the border-box. It can be calculated from the below formula.

$$\text{Extent} = \frac{\text{No. of pixels in region}}{\text{No. of pixels in the bounding box}}$$

The color element is an important feature in representing an image. This feature is most important because it does not change rotation, transformation, and scale. The key elements involved in color feature extraction are color space, similarity measurement, and calibration. Color instances are mainly defined by mean and standard deviations.

$$\text{Mean } (\mu) = \frac{\sum_{i=0}^M \sum_{j=0}^N P(i, j)}{MN}$$

$$\text{Standard Deviation } (\sigma) = \sqrt{\frac{\sum_{i=0}^M \sum_{j=0}^N (P(i, j) - \mu)^2}{MN}}$$

#### D. Classification techniques

To classify a leaf according to their species, the values that are extracted from the pre-processing stage are considered and such as

Mean, Standard Deviation, Convex hull ratio, Isoperimetric Quotient, Eccentricity, and entropy. After the feature extraction phase, the leaf factor of the particular leaf is calculated using a suitable machine learning algorithm like Weka (Weka is a collection of different machine learning algorithms that are written in Java and it is opensource software)

#### E. The Overall System Architecture

In the proposed system server-side admin can log in with his credentials and can save images of leaves. From the user side, the user can upload the leaf images and find the details of the Ayurveda herb. The uploaded and server-side images are compared to identify. The development will be done using Android Studio. Any android phone with an internet connection will be able to run the app. and machine learning algorithms like CNN will be used. By using this application software not only benefits the common people, but also it would be very helpful for experts in fields like the cosmetic industry, botanical gardening, and the medical industry as well.

##### 1) CNN Algorithm

CNN is very simple and almost the same as regular Neural Networks which has some specific weights and bias. Everything that we do for learning an ordinary neural network applies to a convolutional neural network. But the change is that CNN takes an assumption that the inputs are images and thus this allows us to make changes to its architecture. A CNN transforms its neurons in a three-dimension (height, width, depth) form

##### 2) Android Studio

Android Studio is a software that offers more features that enhance the productivity of the mobile application when building Android apps, such as A flexible Gradle-based build system. It is a fast and feature-rich emulator.

And it is a unified environment where users can develop for all Android devices.

### 3) SQL Database

A database in SQL Server is made up of a collection of tables that stores a specific set of structured data. A table in a SQL database contains a collection of rows, also referred to as records or tuples, and columns also referred to as attributes.

### Discussion

The paper has demonstrated an approach to classify plants into their appropriate species using images of their leaves. Ayurveda encourages the use of herbal and non-toxic plants for treatment and the creation of different remedial medications and it requires more understanding about plants and its species. A unique combination of geometry, color, and texture has been identified to maximize identification accuracy with image processing techniques. Features can be calculated for different types of herbaceous leaves and stored in the database which are the values of the training results. With obtained results, the study can notice that both the convolutional neural networks transcended the multi-layered perceptions in the process of validating and testing datasets. The study can evaluate, CNN trained with RGB images performs better than the CNN model trained with grayscale images. The testing accuracy can be considered as the highest accuracy obtained for the classification of Ayurveda herb leaves compared with prior carried out studies. The study used a limited set of data for this study with limited variation in scanned leaf images.

Identification of Medicinal herbs can be very helpful for common people to help them make home remedial medicines and for professionals and students a more effective way of research. The project aims at making an application that is available for free for everyone and on a more common mobile

platform, Android, and can be used for personal or research and study purposes.

### References

- Amara, J., Bouaziz, B., Algergawy, A., n.d. A Deep Learningbased Approach for Banana Leaf Diseases Classification 10.
- Belhumeur, P.N., Chen, D., Feiner, S., Jacobs, D.W., Kress, W.J., Ling, H., Lopez, I., Ramamoorthi, R., Sheorey, S., White, S., Zhang, L., 2008. Searching the World's Herbaria: A System for Visual Identification of Plant Species, in Forsyth, D., Torr, P., Zisserman, A. (Eds.), *Computer Vision – ECCV 2008*. Springer Berlin Heidelberg, Berlin, Heidelberg, pp. 116–129. [https://doi.org/10.1007/978-3-540-88693-8\\_9](https://doi.org/10.1007/978-3-540-88693-8_9)
- Br, P., 2016. Ayurvedic Plant Species Recognition using Statistical Parameters on Leaf Images 11, 7.
- Dhingra, G., Kumar, V., Joshi, H.D., 2018. Study of digital image processing techniques for leaf disease detection and classification. *Multimed. Tools Appl.* 77, 19951–20000. <https://doi.org/10.1007/s11042-017-5445-8>
- Gwo, C.-Y., Wei, C.-H., 2013. Plant Identification through Images: Using Feature Extraction of Key Points on Leaf Contours. *Appl. Plant Sci.* 1, 1200005. <https://doi.org/10.3732/apps.120005>
- Kumar, P.M., Surya, C.M., Gopi, V.P., 2017. Identification of ayurvedic medicinal plants by image processing of leaf samples, in: 2017 Third International Conference on Research in Computational Intelligence and Communication Networks (ICRCICN). Presented at the 2017 Third International Conference on Research in Computational Intelligence and Communication Networks (ICRCICN), IEEE, Kolkata, pp. 231–238. <https://doi.org/10.1109/ICRCICN.2017.8234512>
- Mzoughi, O., Yahiaoui, I., Boujemaa, N., Zagrouba, E., 2013. Advanced tree species identification using multiple leaf parts image queries, in: 2013 IEEE International Conference on Image Processing. Presented at the 2013 20th IEEE International Conference on Image Processing (ICIP), IEEE, Melbourne, Australia, pp. 3967–3971. <https://doi.org/10.1109/ICIP.2013.6738817>



Pramanik, S., Bandyopadhyay, S.K., Bhattacharyya, D., Kim, T., 2010. Identification of Plant Using Leaf Image Analysis, in: Kim, T., Pal, S.K., Grosky, W.I., Pissinou, N., Shih, T.K., Ślęzak, D. (Eds.), *Signal Processing and Multimedia*. Springer Berlin Heidelberg, Berlin, Heidelberg, pp. 291–303. [https://doi.org/10.1007/978-3-642-17641-8\\_35](https://doi.org/10.1007/978-3-642-17641-8_35)

Preprocessing steps of leaf images: a) original image; b) greyscale... | Download Scientific Diagram [WWW Document], n.d. URL [https://www.researchgate.net/figure/Preprocessing-steps-of-leaf-images-a-original-image-b-greyscale-image-cafter\\_fig1\\_320290546](https://www.researchgate.net/figure/Preprocessing-steps-of-leaf-images-a-original-image-b-greyscale-image-cafter_fig1_320290546) (accessed 10.31.19).

Preprocessing steps performed on an Acer Palmatum leaf image. | Download Scientific Diagram [WWW Document], n.d. URL [https://www.researchgate.net/figure/Preprocessing-steps-performed-on-an-Acer-Palmatum-leaf-image\\_fig1\\_282148402](https://www.researchgate.net/figure/Preprocessing-steps-performed-on-an-Acer-Palmatum-leaf-image_fig1_282148402) (accessed 10.31.19).

Sun, Y., Liu, Y., Wang, G., Zhang, H., 2017. Deep Learning for Plant Identification in Natural Environment. *Comput. Intell. Neurosci.* 2017, 1–6. <https://doi.org/10.1155/2017/7361042>  
Venkataraman, D., Mangayarkarasi, N., 2016. Computer vision based feature extraction of leaves for identification of medicinal values of plants, in: *2016 IEEE International Conference on Computational Intelligence and Computing Research (ICCIC)*. Presented at the 2016 IEEE International Conference on Computational Intelligence and Computing Research (ICCIC), IEEE, Chennai, India, pp. 1–5. <https://doi.org/10.1109/ICCIC.2016.7919637>

### Acknowledgement

The authors would like to express the heartfelt gratitude to the research supervisor Professor

R.P.S. Kathriarachchi for his valuable and constructive suggestions during the planning and development of this research and his willingness to give the time so generously is very much appreciated. Also would like to thank the staff of the Department of Information Technology, Faculty of Computing at KDU.

### Authors Biography



Anuradha Kurunayaka is an undergraduate of Intake 34, Faculty of Computing, and Department of Information Technology at General Sir John Kotelawala Defence

University.

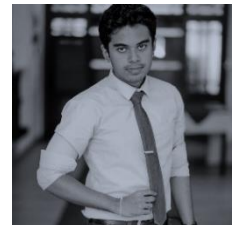

D.P.M. Lakshan is an undergraduate of Intake 34, Faculty of Computing, and Department of Information Technology at General Sir John Kotelawala Defence

University.



R.P.S. Kathriarachchi obtained his BSc (Hons) in computer networks from the University of Wolverhampton UK and his master's degree in MIT in the same university. He also a CISCO certified network associate and having more than 15 years of IT and IS systems. His current research interests include the Internet of Things, Machine Learning, SWARM technologies. He has produced over ten peer-reviewed publications under his name.

## Automate Timetable Scheduling with AI: A Review

C L T H Gajanayake#, W P J Pamarathne

*Department of Computer Science, Faculty of Computing, Sir John Kotelawala Defense University, Sri Lanka*

#chathushaka97@gmail.com

**Abstract :** Scheduling timetables are one of the complex and time-consuming process when constructing using manual methods. These manual methods don't always promise the optimum schedule plan and leads to countless conflicts. Recently, there are many states of the art systems proposed for the task scheduling using Artificial Intelligence (AI). This paper reviews the recently propose timetable scheduling systems with AI. The result of the analysis shown that the evolutionary techniques has been used in many studies to generate optimize timetable schedule specially using the Genetic Algorithm. Most of the studies proved that the Genetic Algorithm optimizes most of the constraint and fitted to automate timetable scheduling.

**Keywords:** Scheduling, Timetable Automation, Artificial Intelligence, Genetic Algorithm

### Introduction

Time is more important in present world. There are endless opportunities, but we have only 24 hours a day. So time management is very important and timetable is most common method to manage time. Every institute has a schedule to do their operations. Most of the schedules are fixed. For example, in Sri Lanka typical office hours are between 8AM to 5PM. Most government and private sector institutes have fixed timetables or schedules. Those schedules cannot be changed, and flexibility is minimum. Those schedules haven't changed or updates since last 3 – 4 decades. But in present world population and human needs are growing exponentially. So we need a

flexible scheduling systems that are not static or fixed. We need dynamic schedules that can evolve according to situations. Best example for this is Colombo morning and evening traffic jams. Since all institutes have static and not upgrading schedules, everyone needs to be at office on 8AM. Population and needs are growing. But infrastructure is not developing according to those needs. For example, let's consider about roads. In Sri Lanka we import lot of vehicles. But our main roads still only have two lanes. So it is clear we have limited resources. Because of that we have to spend more time on road. We have to sacrifice our limited time for that cause. But imagine if we have dynamic schedules that changes according to the traffic. In these days work from home is very popular. If we can change our working hours how easy it is. In practically this might be difficult.

Since we cannot apply dynamic schedule to whole country, we can experiment this in our university. My aim is to create dynamic scheduling system, which updates timetables according to the situation. For example if a lecturer cannot attend to the lecture tomorrow lecturer can request to change his lecture in to another time. Then the system should able to swap other lecture with this lecture without clashes. Then both students and lecturers can save their time. This paper focuses techniques and methods which are used in Scheduling and timetable projects and systems and analyze and review them.

In this study we pay focus on which areas to consider and which constraints should consider when creating a timetable system.

Since we focus only about faculty of computing in KDU, main constraints which are considered is time availability of lecturers, resources and subjects. These are some factors which we should avoid clashing each other.

### Literature Review

When it comes to scheduling problems, we cannot create universally applicable application to solve every scheduling problem. (McCollum et al., 2012a) In this study my main aim is to create application that can automate faculty of computing timetable scheduling system. Currently timetable scheduling done by manually. It is less efficient and consume lot of time. And also, it is less flexible because timetables cannot change easily. It takes lot of time to recreate timetable without any clashes because there are lot of things to consider.

Most of researches are base on few technologies and algorithms. Among those algorithms Local Search Procedures are more often used in researches and projects. (Burke et al., 1995a). Before come to conclusion we should discuss about those technologies and algorithms first.

#### A. Local Search Procedures

This is one of common technology which used to create scheduling problems. Tabu Search, Simulated Annealing and Genetic Algorithm are Local Search Procedures. Genetic Algorithm is most commonly use algorithm. Let us discuss above methods.

#### B. Simulated Annealing (SA)

This method is based on probabilistic method that is applied like the global optimum of given function. When it comes to huge search space simulated annealing gives accurate global optimization (Pillay and Özcan, 2019a). This method is good for use when it comes to search space is different. This technique gives good results for an optimization dilemma. If our problem

contains condition that we want to reduce or maximize parameters or other thing, that problem can be solved by Simulated Annealing in most cases. Simulated Annealing starts using initializing random solutions first. Main procedure of this method is generating random solutions which is neighbors of the current solution using loop. Structure of the problem define the definition of the neighboring solutions.

#### C. Tabu Search

Tabu search algorithm can handle huge relations of derivative approach that can handle and create memory structure in metaheuristics. Tabu search and parallel tabu search is examples. Tabu search is meta strategy or metaheuristics which can use for get calculations from surrounding heuristics. Ans it is also a global optimizing algorithm (Islam et al., 2016a). To solve optimization problem this approach is used mostly.

Fred Glover's ideas are based for tabu search. This method is used to find solutions using meta-heuristics approach which search and explore the solutions which are in beyond the local optimality. Over the last decades this method became very popular because this method could produce or give best possible answer or solution that near to the best possible solution. Since tabu search have adaptive memory feature, this method has very flexible search behaviors (Burke et al., 1995b).

#### D. Genetic Algorithm

This algorithm is invented by John Holland. He wrote a book about genetic algorithm called "Adaptation to natural and artificial systems.". Genetic algorithm is based on Evolutionary Algorithms (Al-Majmar and Al-Shfaq, 2016a). This algorithm uses natural collection principle to create and develop to give best solution as outcome. Genetic algorithm is also a heuristic search which have natural evolution features like mutation, inheritance, crossover and

selection to generate solutions to optimize and get good solutions for a problem (AlMajmar and Al-Shfaq, 2016a; Rozaimie et al., 2017a; Salvi et al., n.d.).

Genetic algorithm is used commonly to develop scheduling systems. When scheduling a timetable there may be set of solutions that doesn't violate constraints. So, when using a genetic algorithm we get pool of good solutions. So, using this algorithm we cannot obtain best answer. Because of evolutionary features like mutation and crossover this algorithm is more efficient and take less time to search.

#### E. The Constraint Programming (CP)

The main feature of this method is, this method can clearly recognize the constraints as a part of the program. This pays the way to adaptability which is a need feature of scheduling timetables (Gervás and Miguel, n.d.). By backtracking search and condition passing this method can narrow down the search domain. This can minimize time to search. In present constraint programming languages do not need to plan functions explicitly (Department of CSE, SDMIT Ujire, Karnataka, India et al., 2017). There are some main drawbacks of this approach. They are, Hard to define soft constraints Potential problems with enhancing the initial feasible solutions.

#### F. Heuristic selection methodologies

In this methods solution are formed gradually. Initially this method starts with empty solution. Then this approach can intelligently select and construct a complete solution. This approach uses SCFG rules to create the system components needed to create schedule. Stochastic context-free grammar (SCFG) lot alike context free grammar (CFG). Heuristic selection contains hyper heuristic framework, which have many pre-existing constructive heuristics. Main challenge is to find relevant heuristic

according to the problem. Until the complete solution obtained this cycle continues.

#### Methodology

In literature review, most projects used genetic algorithm for the timetable scheduling systems. For my project I also chose genetic algorithm. Since I design a timetable system for the faculty of computing in KDU, this application is based on the requirements of the faculty. There are soft and hard constraints when scheduling a timetable. Hard constraints cannot violate in any means. Soft constraints should try to avoid violations. Since there are lot of possible answers for a problem, sometimes soft constraints can be ignored. In computer faculty there are some main constraints identified. They are,

- Visiting lecturers get priority when scheduling timetables. They are assigned first according to their available time.
- Then inhouse lecturers are assigned according to their availability.
- No lecturer can have two lectures at same time and tow lecturers cannot have lectures at same time.
- There are Computer science, Software engineering and computer engineering majors in the computer faculty. They have separate selective subjects. Those selective lectures cannot be clashed.

And when consider about soft constraints they are,

- Inhouse lecturers cannot have two lectures have two lectures at one day.

After identifying constrains we can try to develop the chromosome representation of the genetic algorithm for the timetables. A single chromosome is a solution. We can generate those chromosomes randomly according to our need. Then we have to

create population of chromosomes. Chromosome representation is one of hard tasks of this approach. KDU typically ends at 2.30PM. So there are 4 time periods and two sessions in most time. In rarely there are lectures at 3-5PM. Then we can assign value for each timeslot. This is considered as a chromosome. Chromosome contains genes. Those genes represent details about the lecture.

After designed chromosome representation we need a selection method. We build fitness function which can calculate the fitness of the chromosome. When we have more fitness, it is a better solution. We can implement fitness function according to the constraint violation of a chromosome. We can declare required accuracy for the fitness function.

Then we have to select chromosomes from the population which do not have required fitness level. Then we perform mutation and crossover until the required level is achieved.

## Discussion

### A. Limitations in Existing Systems

Allocating a timetable for a primary school may seem like easy task because there are only few subjects and most importantly they are fixed. So it is not a difficult task to schedule a timetable manually. But when comes to the university level there are many aspects to consider when scheduling a timetable. Many subjects and modules. Lot of elective subjects and limited space or lecture rooms etc. So, there are lot of constraints. Even automatic systems face difficulties when meet these types of constraints. So, it is very important to consider limitations in existing systems and technologies.

When considering Simulated Annealing it is very heavy computational heavy function. And also other major drawback is this method cannot select optimal solution by itself. But this have advantages also. Simulated Annealing is easy to code even for

complex problems. And also it also gives good solutions

Genetic algorithm is most used in automated timetable systems. But it also has both advantages and disadvantages. So when considering disadvantages genetic algorithm might not find the most optimal solution to the defined problems in all cases. The first and most important consideration in creating a genetic algorithm is the definition of a representation of the problem. The language in which the solution candidates are specified must be robust. Hard to choose parameters like population size, generation number etc. A major obstacle in genetic algorithms is the coding of the fitness (evaluation) function to achieve higher fitness and better solutions to the problem at hand. A wrong choice of fitness function can lead to critical issues, such as the resolution of a problem can not be found or worse, and lead to a wrong solution of the problem. It is very hard to find a good heuristic reflects the algorithm we need. And also when we use genetic algorithm for a system it is computationally expensive. So we might need to upgrade our existing machine to implement this system. Genetic algorithm need less information on the problem. But drawback is designing an objective function, representation and operators right can be difficult.

But Genetic Algorithm has advantages also. Coding is really is when compared to other algorithms. GA can find a solution in a very less time. Concept is easy to understand.

We do not have a fully automated system to schedule timetable in universities in Sri Lanka. Existing manual systems are observed with some problems. Some parts of the existing system is not efficient enough. Some generated timetables have course clashing. So it need to fix. Other major problem in existing systems are vulnerability to error due to human factors like stress and fatigue. As mentioned above universities

contain many courses and modules. Lot of elective subjects. So it is very hard to schedule a timetable. Doing such tasks may find very stressful for the employees in the university. Also unavoidable data omission because of too many data in the collection. Data redundancy is a inherent problem in manual system.

### Conclusion

Information technology has evolved in recent decades. The schedule software applications have been adapted and enabled to generate and optimize more appropriate timetables in an automated environment for higher education institutions. Literature research revealed that applications from reputable vendors were gradually adjusting the use of spreadsheets, a database management system, schedule editors, web-based tools, and an improved graphical user interface. Timed software applications thus use modern techniques (prior art) and are therefore able to use them.

The other component includes the working mechanism, the solution method, and the algorithm used to create a work plan. The timing problem is very challenging and many possible combinations need to be explored to find a list of acceptable solutions. Since it is impractical to list all combinations, one will choose an approach that calculates a subset or part of it. Such algorithms can give an approximation that is considered an acceptable solution. Heuristic algorithms therefore seem to surpass traditional methods, and such algorithms are even combined to reinforce one another. The latest developments can be found in the field of hyperheuristics. Such solution strategies aim to generate timetables by choosing the right algorithms. However, commercial timetable products do not seem to focus on the actual implementation of such solution methods in timetable applications.

### Reference

Al-Majmar, N.A., Al-Shfaq, T.H., 2016b. Solving of Lectures Timetabling Problem and Automatic Timetable Generation using Genetic Algorithm. *International Journal of Advanced Research in Computer and Communication Engineering* 5, 505–512. <https://doi.org/10/ggbd7g>

Almu, A., Muhammad, A.B., 2013. ISSN: 1597 – 9928 <http://www.wiloludjournal.com>  
doi:10.5707/cjappls.2013.8.3.23.30

AUTOMATING LECTURES TIMETABLE USING CONSTRAINT SATISFACTION TECHNIQUE 9

Burke, E., Elliman, D., Weare, R., n.d. The Automated Timetabling of University Exams using a Hybrid Genetic Algorithm 8.

Burke, E.K., Elliman, D.G., Weare, R.F., 1995b. The Automation of the Timetabling Process in Higher Education. *Journal of Educational Technology Systems* 23, 353–362. <https://doi.org/10/fmpk5k>

Delgado, A., Pérez, J.A., Pabón, G., Jordan, R., Díaz, J.F., Rueda, C., 2005b. An Interactive Tool for the Controlled Execution of an Automated Timetabling Constraint Engine, in: Van Roy, P. (Ed.), *Multiparadigm Programming in Mozart/Oz*. Springer Berlin Heidelberg, Berlin, Heidelberg, pp. 317– 327. [https://doi.org/10.1007/978-3-540-31845-3\\_26](https://doi.org/10.1007/978-3-540-31845-3_26)

Department of CSE, SDMIT Ujire, Karnataka, India, M, S., Vaze, P.K., Department of CSE, SDMIT Ujire, Karnataka, India, Pradeep, Department of CSE, SDMIT Ujire, Karnataka, India, N R, M., Department of CSE, SDMIT Ujire, Karnataka, India, 2017. Automatic Time Table Generator. *IJARCSSE* 7, 204–211. <https://doi.org/10/ggbd68>

Emmanuel, E., Friday, A., Onoja, Omolola, Y., Serah, 2019. Design of Automated Departmental Lecture Timetable System. *Review of Computer Engineering Research* 6, 24–34. <https://doi.org/10/ggcb34>

Gervás, P., Miguel, B.S., n.d. Sequential Building of Constrained Timetables Using Rule-Based Heuristics: An Expert System for Automated Timetabling at UEM 12.

Islam, T., Shahriar, Z., Perves, M.A., Hasan, M., 2016b. University Timetable Generator Using

- Tabu Search. JCC 04, 28–37. <https://doi.org/10/ggbd7k>
- Klevanskiy, N.N., Antipov, M.A., Krasnikov, A.A., 2017. Cognitive Aspects of Timetable Visualization: Support Decision Making. *Procedia Computer Science* 103, 94–99. <https://doi.org/10/ggcb33>
- Mahgoub, H., Altaher, M., 2013. Automated Timetabling Using Stochastic Free-Context Grammar Based on Influence-Mapping. *IJACSA* 4. <https://doi.org/10/ggbd63>
- McCollum, B., Burke, E.K., 2014. The practice and theory of automated timetabling. *Ann Oper Res* 218, 1–2. <https://doi.org/10/ggcb36>
- McCollum, B., McMullan, P., Parkes, A.J., Burke, E.K., Qu, R., 2012b. A new model for automated examination timetabling. *Ann Oper Res* 194, 291–315. <https://doi.org/10/dksvzq>
- McCollum, B., Schaerf, A., Paechter, B., McMullan, P., Lewis, R., Parkes, A.J., Gaspero, L.D., Qu, R., Burke, E.K., 2010. Setting the Research Agenda in Automated Timetabling: The Second International Timetabling Competition. *INFORMS Journal on Computing* 22, 120–130. <https://doi.org/10/bvhq4p>
- Meng, L., Muneeb Abid, M., Jiang, X., Khattak, A., Babar Khan, M., 2019. Increasing Robustness by Reallocating the Margins in the Timetable. *Journal of Advanced Transportation* 2019, 1–15. <https://doi.org/10/ggcb35>
- Murray, K., Muller, T., n.d. Automated System for University Timetabling 7
- Ojha, D., Kumar, R., Das, S., 2016. Automated Timetable Generation using Bee Colony Optimization. *IJAIS* 10, 38–43. <https://doi.org/10/ggbd6z>
- Oude Vrielink, R.A., Jansen, E.A., Hans, E.W., van Hillegersberg, J., 2019. Practices in timetabling in higher education institutions: a systematic review. *Ann Oper Res* 275, 145–160. <https://doi.org/10/ggcb37>
- Pillay, N., Özcan, E., 2019b. Automated generation of constructive ordering heuristics for educational timetabling. *Ann Oper Res* 275, 181–208. <https://doi.org/10/ggbd6p>
- Rozaimie, A., Shafee, A.N., Hadi, N.A.A., Mohamed, M.A., 2017b. A Framework for University's Final Exam Timetable Allocation Using Genetic Algorithm 7.
- Salvi, A., Khanvilkar, O., Balkhande, B.W., n.d. Automatic Time-Table Generation System using Genetic Algorithm 5, 3.
- Sampebatu, L., Kamolan, A., n.d. TIMETABLE MANAGEMENT USING GENETIC ALGORITHMS 6.
- Schaerf, A., 1999. [No title found]. *Artificial Intelligence Review* 13, 87–127. <https://doi.org/10/ffkzrt>
- Schonberger, J., Mattfeld, D.C., Kopfer, H., 2000. Automated timetable generation for rounds of a table-tennis league, in: *Proceedings of the 2000 Congress on Evolutionary Computation. CEC00 (Cat. No.00TH8512)*. Presented at the 2000 Congress on Evolutionary Computation, IEEE, La Jolla, CA, USA, pp. 277–284. <https://doi.org/10/chdq47>
- Xu, T., Zhou, L., Bai, Z., Li, W., Guo, B., Wang, Z., 2019. The Research on Big Data Platform based on Timetable Management. *IOP Conf. Ser.: Mater. Sci. Eng.* 569, 052081. <https://doi.org/10/ggcb38>

## Impact Of Traditional Supply Chain Management On Green Supply Chain Management

HMS Ayeshi#, LBL Senevirathne and WMSRB Wijerathne

*Department of Information Technology, Sir John Kotelawala Defence University*

#35-is-003@kdu.ac.lk

**Abstract:** In industrial arena, Supply Chain Management is the process of converting raw materials into finished goods and services within a quick delivery time with a minimized wastage capacity. Concept of Green Supply Chain Management is an upgraded process of Traditional Supply Chain Management which mainly focuses on the green manufacturing, green packing, green delivering and marketing. Surveys state that Traditional Supply Chain Management is a main reason for the hazardous problems like environmental degradation, pollution, carbon emission, resource depletion and massive wastage of raw materials. To suppress and reduce these harmful problems logisticians and consultants introduced the concept of Green Supply Chain Management. After the implementation of the Green Supply Chain Management process experts found that the level of above mentioned harmful problems have been reduced. First part of this paper discusses about the concepts of Traditional and Green Supply Chain Management. It also discusses about the burning issues in Traditional Supply Chain Management and how the Green Supply Chain Management was introduced to overcome those problems. Next part discusses the transition barriers and challenges that encounter when implementing the Green Supply Chain Management. Finally, the paper reveals the main objective of the research; the impact of Traditional Supply Chain Management on Green Supply Chain Management and the suggested solutions for those facts.

**Keywords:** Traditional Supply Chain Management, Green Supply Chain Management, SCM, GSCM

### Introduction

As a result of industrialization and the competition in the global market, most of the organizations and companies are compelled to consider the customers' demands and requirements. When considering the marketing process, those companies have the responsibility of increasing the manufacturing process and reducing the delivery time of the products. In this current competitive marketing scenario, it is significant to study the concept of Supply Chain Management as companies have to encounter many

challenges in providing the products which are up to customer expectations at an affordable cost.

The definition of the term Traditional Supply Chain Management (TSCM) in industrial jargon can be simply interpreted as the conversion of raw materials into finished goods and products and also delivering the products in time to the end-users (Parkhi, 2015). Besides that, it is the combination of key business processes that provide product and services from the suppliers to end-users within a short delivery time (Janvier-james, 2012). TSCM has been applied to accomplish basic purposes such as profit maximization, maximization of operating performance, and to develop the interrelationships and better management within the organization (Stock, Boyer and Harmon, 2010a). As researches



mentioned, the history of TSCM goes back to the early 1980s and the concept itself has been launched by the experts of the management arena and the consultants of the logistics (Habib, 2014). It is evident that TSCM is the most important and the vital concept in management since its inception.

The concept of Green Supply Chain Management can be delineated as an integration of sustainable environmental criteria with the concept and the practices of Traditional Supply Chain Management (Luthra et al., 2011). Basically, TSCM deals with five main components which include raw material, industry, distribution, consumer, and, waste (Sulistio and Astuti, 2015). As the logisticians and management experts state, the linkage and the relationship of the above main components pose many threats including environmental pollution and depletion of resources. Therefore, as a solution to the harm caused by TSCM to the environment, the concept of GSCM was firstly introduced in 1994 (Shan and Wang, 2018). Afterward, the above-mentioned problems were gradually reduced to a greater extent. Further, the organizations and the industries started to use the eco-sustainable supply chain practices so that it was a massive encouragement to end the environmental degradation (Shan and Wang, 2018).

When establishing the GSCM instead of TSCM, the organizations and the industries had to encounter considerable disadvantages along with the benefits while fulfilling the end-user expectations. Organizations had to consider both social and economic factors when launching the GSCM concept within the organization (Luthra et al., 2011). In addition to that, there were various beliefs and restrictions among the society (basically among the employees) when changing into GSCM concepts such as some employees did not prefer to change, and they liked to

continue with the existing concept. In this light, the objective of this study is to analyze the impact on TSCM on GSCM while focusing on its effect on the production process.

### Litratue Review

The term Supply Chain Management (SCM) can be exemplified as the management of the process of converting the raw materials in to finished goods which are up to customer expectations and delivering those products and services to the customer in a quick delivery time (Swanson et al., 2018). Further, it is the process of integrating the key business processes from the supplier to the end-user. After introducing the concept of Traditional Supply Chain Management (TSCM) in early 1980's, the manufacturing process in most of the industries was rapidly increased and it was mainly focused on the basic purposes such as profit maximization, development of the interrelationships, maximization of operating performance and management within the organization (Stock, Boyer and Harmon, 2010a). Essentially, a supply chain can be considered as an inter-linked network of individuals, organizations, activities, resources and technologies involved in the manufacturing industry and the management of this combination will provide the expected goods and services to the customers at a considerable price (Croom, Romano and Giannakis, 2000). Having an effective and efficient management of the traditional supply chain, industries and organizations wish to have the benefits such as linking the manufacturer, supplier and customer, having the utmost use of the shared resources both internal and external of the organization, low cost, added value and increased customer satisfaction (Stock, Boyer and Harmon, 2010a). As the experts mentioned Technical, Managerial, and Relationship are the three major perspectives that challenge Supply Chain Management (Patil, 2015). These three types of perspectives affect when

implementing the concept of SCM. Many research mention some other challenges that arise when implementing a supply chain such as procurement management, and globalization (Fernandes et al., 2014). Here, procurement management refers to the challenges that have to be encountered when procuring the products from the suppliers and the globalization refers how to cut cost and grow simultaneously. Furthermore, it is essential to study the concept of the Traditional Supply Chain Management especially about its key processes, challenges and barriers encountered when implementing the supply chain because having an undoubtful knowledge about this concept will help to clarify the problems in industrial and manufacturing parlance.

As the consultants, and logisticians depict there are five main stages in a TSCM which acts like a cycle specifically planning, developing, making, delivering and returning (Giménez et al., no date). As the initial stage of a TSCM, in the planning stage it is necessary to develop a plan or a strategy which depicts how the product and services will appease the demands and the expectations of the customers. In the developing stage it is necessary to concentrate not only about building a strong relationship with the raw material suppliers, but also should identify the trustable delivery methods and payment methods of the products. After completing this stage, the responsible managers such as supply managers can combine all these processes together for handling their inventories. Starting the manufacturing process according the customer's demand is done in the third stage and the supply manager should schedule all activities required to be done in manufacturing, testing, packaging and delivery. This stage also known as the most metric-intensive unit in the conventional supply chain process. Manufactured products and services are

scheduled to deliver to the customers at their destined locations is done in the fourth stage: the delivering stage. The final stage is the returning stage which referred as the return. Damaged and the destroyed products are returned by the customers to the suppliers is done in this stage. It is essential to deal with the customer responds and feedbacks. This is the process of traditional supply chain which shows the typical flow of converting the raw materials in to demanded products until the delivery and return of those products. (Croxtton et al., 2001)

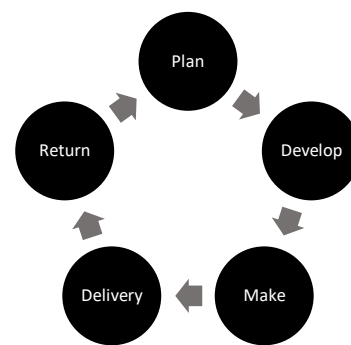

Diagram 1. Supply Chain Process  
Source: Author Designed

With the upheaval of industrialization; organizations and manufacturing industries had to face many challenges and problems not only socially but also economically as the Conventional Supply Chain Management Systems was the reason for many of those problems (Groznika and Trkman, 2015).

- Environmental degradation including environmental pollution and depletion of resources.
- The wastage of energy, emission and chemical and solid waste.
- Increased costs of raw materials and other infrastructure.
- Consumer demands shows the need for quality products and services.
- Unforeseen delays.

To overcome the above-mentioned challenges and problems the consultants and logisticians introduced the concept of GSCM

firstly in 1994 as a higher modification of TSCM after accomplishing many surveys and experiments and they observed that many of those problems can defeat by launching the GSCM concept throughout the industries and organizations (Aslinda et al., 2012). GSCM followed the basic practices used in TSCM with the integration of eco-sustainable practices as an issue was aroused that TSCM concept causes environmental degradation including environmental pollution and depletion of resources (Shan and Wang, 2018). To stop this environmental degradation the consultants and the logisticians modified the TSCM concept into ecological supply chain management concept (Jayant and Azhar, 2014). As such, GSCM concept can be delineated as green purchasing, green manufacturing, green packing, green delivering and marketing (Dashore and Sohani, 2021). Other than that, it reduced the waste in the form of energy, emission and chemical and solid wastage (Luthra et al., 2011). In order to minimize these harmful facts, a proactive GSCM was suggested to improve the environmentally sustainable supply chain concept. In terms of greening the TSCM concept, the Interpretive Structural Modelling (ISM) technique was used and it was introduced in Indian industries (Rahman et al., 2020). This ISM technique was advantageous to eliminate the caused barriers when implementing the GSCM concept. The main purpose and the focused area of GSCM concept was analyzing the benefits, costs, and risks associated with the environmental performances. According to the other researches there are three main phases in manufacturing process namely resource utilization decrement, waste decrement and finally the emission decrement (Muysinaliyev and Aktamov, 2014). Reverse stage in GSCM mainly focuses on return on products and materials in order to forwarding them to recycling, remanufacturing and refurbishing or safe disposal (Zulkefli, Mahmud and Zainudin,

2019). GSCM can be considered as one of the best strategies introduced in order to minimize the environmental degradation as in this current turbulent industrial upheaval the environmental issues cause the most harmful damages to the society in industrial and manufacturing arena (Bhattacharjee, 2017). Altogether, above mentioned facts depict that GSCM process follows the same practices used in TSCM combined with ecological facts. However, surveys state that after preceding the GSCM concept and the qualities of the new concept helped to overcome the problems and challenges caused due to TSCM.

After the experts recognized the need of eco-sustainable supply chain to the manufacturing industry, there were many barriers occurred while implementing the GSCM concept (Series and Science, 2019).

- The lack of integration of IT systems.
- Lack of acceptance of advancement of technology.
- Uncertainty in competing with the rival manufacturing industries.
- The cost of implementing and maintaining is comparatively high.
- Lack of green architects, green developers' green consultants and experts.
- Prevailing culture of the organization.
- Lack of commitment of the top management.
- Lack of resources.
- Lack of technical knowledge and experience.
- Lack in managing standard environmental control policies within the organization.
- Lack of commitment and the support of the government.

- Lack of adequate environmental measures.

These transition barriers were negotiable and should be solved before implementing the GSCM concept. In that era, the developing of the information technology was not in a considerable state. For the implementation process and maintaining process, the need of various computer-based applications, programs and software utility was high in the purpose of exchanging data and information. In case of that, there was a problem when implementing the GSCM concept given the lack of integration of IT systems. Majority of the employees of the industries refused to adapt to the change because of the lack of technological knowledge and they preferred to maintain the existing concept. Likewise, lack of acceptance of advancement of technology was a severe barrier when transition to new concept. Due to the industrialization upheaval the global competitiveness was high so that there was an uncertainty in competing with the rival manufacturing industries. The cost of implementing and maintaining of a GSCM concept was very high than the conventional supply chain management system as there was different types green methodologies to implement such as green manufacturing, green design, green delivering and marketing (Luthra et al., 2011). When launching the green concept instead of traditional concept, an industry needs considerable number of experts, consultants and logisticians with purpose of training employees and maintaining the system. But unfortunately, in that era the amount of expert management such as green architects, green developers and green consultants was a very low to implement this green concept in industries. (Dashore and Sohani, 2021) Likewise, above mentioned barriers caused many problems while in the transition of TSCM to GSCM.

As researches state challenges that must to encounter when implementing the GSCM concept can be divided in to two separate parts namely internal challenges and external challenges (Zulkefli, Mahmud and Zainudin, 2019). Here, internal challenges can be delineated as the challenges that have to face among the employees of the organization and the problems occur inside the organization. Further the challenges that have to face outside the organization in known as the external challenges. When considering the internal challenges there are some major facts that should be considered when implementing the GSCM concept. Most of the time, before executing the implementing process within the organization, it is necessary to consider about the prevailing culture of the organization. Goals, objectives, vision and the mission of an organization can be changed in time to time. Not only that but also if an organization replace their basic cultural fundamentals such as organizational structure (forms of authority), core technology, and operational and marketing strategies, it will be a challenging task when implementing the GSCM concept. It is necessary to have a commitment of the top management when introducing a new concept to the organization because the success or the failure of the organization completely depends on the ability of the managers to motivate the employees in the organization. Managers should encourage the employees; they should train the employees and they should teach them how adapt to the change of the organization. If the top management do not consider about those factors it will be challenge as whole functionalities of the organization depends upon the top management. Internal challenges faced by the organization include lack of resources, lack of technical knowledge and experience and lack in managing standard environmental control policies within the organization. The most significant

external challenge is the lack of commitment and the support of the government. The government of a country should provide necessary infrastructure to the organizations when launching such projects. Lack of adequate environmental measures such as sustainable auditing and certifications like ISO14001 also can be considered as the external challenges when implementing the GSCM within an organization. (Zulkefli, Mahmud and Zainudin, 2019) Likewise, above mentioned challenges may affect when implementing the concept of GSCM both internally and externally.

Not only the challenges and the barriers but also the impact of TSCM on GSCM should be considered when implementing the GSCM concept (Aslinda et al., 2012).

- Competition with rival industries.
- Reluctance of adapt to the change.
- Fear of failure.
- Unawareness of customers, employees and suppliers.
- Non-availability of bank loans to encourage the green concept.
- Lack of understanding about remanufacturing process.
- Implementing the efficient materials and wastage management systems.

Market competition can be considered as one of the most affected impact on GSCM. Basically, the market competition in TSCM would be high because the concept of GSCM is a new experience for the manufacturing industries and the experience gained from this new concept is lower than the experience gained from the concept of TSCM. Because of this, the process of manufacturing would be gradually falling down until the employees adapt to the change. Majority of the customers also only practiced to the traditional concept and new to the green concept. So that it is also an impact of TSCM

on GSCM. As this is a new concept to all the users, there can be a fear of failure. All users have experienced the conventional system, but limited number of users have experienced the new concept. So that the probability of failure is high. Not only the unaware of the customer but also the unawareness of supplier is also may affect badly on GSCM concept. As the execution of green concept makes high costs, majority of the industries have to ask for bank loans. But the problem is non-availability of bank loans to encourage the green concept and maybe it is because of the lack of knowledge of the green concept. This is also can be considered as an impact of TSCM on GSCM. Before practicing the green concept all the organizations used for the functions of traditional concept. In traditional concept organizations did not consider about the recycling or the reusing concept. Although the organizations started to practice the new green concept, they don't care about remanufacturing process severely. Hence, it is also a significant impact of TSCM on GSCM. In addition to that, implementing the efficient materials and wastage management systems is also can be considered as massive impact of TSCM on GSCM. (Luthra et al., 2011)

Given that, for the above-mentioned facts organizations can suggest the solutions as follows.

- Improving the remanufacturing process.
- Financial incentives will encourage the GSCM process.
- Providing proper understanding to the employees.
- Introducing new methods for remanufacturing process.
- Improving the quality of the products.
- Cost effectiveness and efficiency.

- Increasing the market share and the growth in the industry.

Initially, many of the experts mention that, from the construction of activities which have less deteriorated to the environment can improve the remanufacturing process of the industries. With the appropriate financial incentives like tax incentives and subsidies from the government, it will indirectly encourage and increase the construction sustainability and also it will neglect the impact caused by the TSCM concept when implementing GSCM concept. Providing proper knowledge, training programs and experience to the employees of the organization will help to avoid the impacts caused by TSCM concept. Introducing the new methods of reusing, recycling materials and packaging can avoid the waste of raw materials and resources. This also can be considered as a solution for the impacted problems of TSCM. Preceding the ways of cost effective and efficiency will help to cover the costs charged for implementation and maintaining process. Increasing the revenues and decreasing the liabilities will help in cost effective process. Maximization of the market share and the market growth within the industry will be a massive encouragement for a successful GSCM of an organization or an industry. (Dashore and Sohani, 2021)

Thus, above mention factors can be considered as the solutions for the impact of TSCM on GSCM.

### **Methodology**

This study focuses on the challenges encountered by Traditional Supply Chain Management with the introduction of Green Supply Chain Management. As mentioned, in most of the previous studies the concept of GSCM was introduced in order to address the universal problems such as environmental degradation and depletion of resources (Rahman et al., 2020). The objective of this

study is to analyze the impact of Traditional Supply Chain Management on Green Supply Chain Management and to identify how the changes occurred in the production process.

In this manner as the first step of the review, it clearly describes the concept of Traditional Supply Chain Management and how it firstly introduced. Regarding the second step, the review depicts the challenges in TSCM. Evolution of Green Supply Chain Management due to the challenging problems in TSCM and a clear introduction about the GSCM concept is described in the third part of the review. Next part depicts the barriers and the challenges that encounter when implementing the concept of GSCM. As the fifth part, the review describes the impact of TSCM on GSCM and in the last part of the review it illustrates the suggested solutions.

The study adopts a qualitative approach as well as a systematic literature review since the qualitative approaches targeted on revealing the etiquettes and the perception of the society with reference to a particular topic. This type of approach encapsulates not only “what” people think, but also “why” people think so. Qualitative approach research allow revealing and probing a particular problem in-depth and it helps to reach a comprehensive conclusion. A Systematic Literature Review (SLR) can be considered as a type of literature review that aims to address a problem by analyzing, critically evaluating and integrating the collected secondary data. On this wise, this study also can be premeditated as a SLR since it is mainly based on identifying, evaluating and integrating the secondary findings.

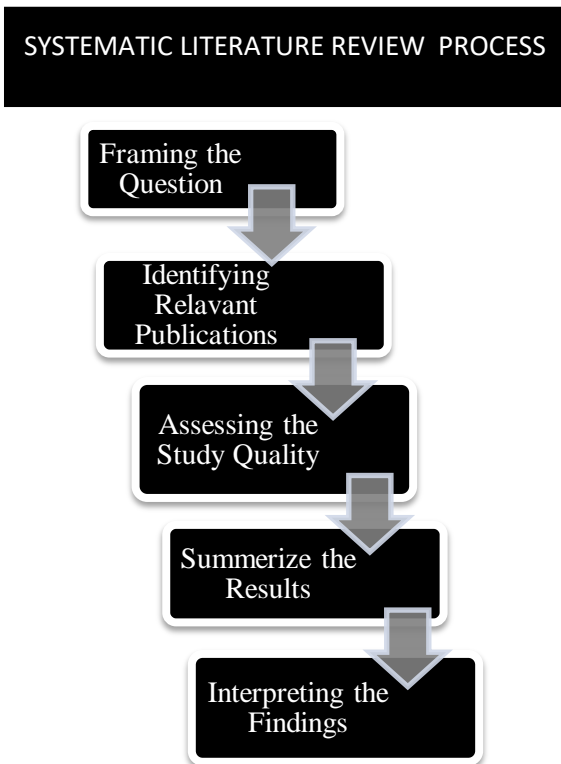

Diagram 2. Systematic Literature Review Process  
Source: Author Designed

Furthermore, Given that the study is a highly conceptual and the concept of eco-sustainable supply chain management is still a potential concept in industrial arena, data collection was done mainly through document analyzing. Though it is an obstruction for data collection process, the findings provide considerable facts to substantiate the objective of the study. Throughout the study 30 review papers published between 2000-2019 including the journals where business and economic management institutions, operational management and logistics academics and the papers published by logisticians and economic consultants were used to gather data and they were analyzed to achieve the objective of the study.

### Barriers to Implement Gscm

The execution process of the GSCM concept within industries and organizations caused some significant barriers and it is necessary to overcome those barriers to implement a successful GSCM. It is obvious

that it costs higher amounts for implementation process and the maintaining process of the GSCM concept deals with the eco-sustainable practices (Series and Science, 2019). Industries have to introduce new recyclable, reusable and refurbish methods in order to execute a complete GSCM process within the industry (Bhattacharjee, 2017). Thus, it takes higher costs to introduce these new methods and those introduced method should be maintained properly in order to protect them from the damages which can occur due to various conditions (Maryniak, 2019). Machines and other equipment should be upgraded when it is required. The expenses for maintenance are also high. Most of the employees in the industries are experienced in working with the conventional system. This can be a reason for rejecting the new GSCM concept within an industry. This new concept includes various kinds of advanced technological concepts and due to the lack of knowledge regarding the advanced technologies among the employees causes a main reason for lack of acceptance of advanced technologies (Jayant and Azhar, 2014). Surveys state that this GSCM concept was firstly introduced in 1994 and in this era the technological advancement was very poor. But as mentioned above, this new concept consists of many technological equipment. Given that, lack of integrated IT systems was a massive problem when implementing a GSCM. As this is a totally new concept for the manufacturing industry, all the industries and the organizations feared that their own industries will face failures in the manufacturing process (Rahman et al., 2020). Because of that they had worked hard for the survival in the industry and to maintain the competitiveness of the industry with the rival industries. If the new concept is not working properly, organizations face losses instead of having profits. (Dashore and Sohani, 2021). Unlike in conventional supply chain management, to implement a GSCM

concept within an organization it is necessary to have green developers, green architects, green consultants and experts. Without having aids from those experts, organizations cannot implement a successful GSCM. It is known that these consultants are very rare in the field and the cost to procure such experts is very high. Such that, lack of green consultants is a huge problem to implement a GSCM (Maryniak, 2019). Top management should involve when implementing the new concept as they should instruct and motivate the employees for a successful implementation. Top managers should provide necessary resources when it is needed. If the top managers ignore their responsibilities, issues can arise when implementing the new concept. Lack of commitment of the top managers and lack of resources are other major problems that have to be encountered while implementing the GSCM concept (Dashore and Sohani, 2021).

Thus, above mentioned facts depict the barriers when implementing the concept of GSCM within an organization.

### **Conclusion**

Supply chain management is the process of converting raw materials in to finished goods and services and delivering them to customers in a quick delivery time (Parkhi, 2015). Traditional Supply Chain Management was introduced in early 1980's. This TSCM concept was a main reason for the profit maximization, development of the interrelationships, maximization of operating performance and management within the organization (Stock, Boyer and Harmon, 2010b). Not only that but also this TSCM concept was a major reason for some environmental problems which affect socially and economically for the industries and organizations. Environmental degradation, wastage of energy, higher costs, need for quality products and services and unforeseen delays are some problems that

arise when practicing the TSCM concept. To overcome these problems logisticians, consultants and experts introduced the concept of GSCM in 1994 (Shan and Wang, 2018).

GSCM concept can be defined as the process of green planning, green developing, green making, green delivering and returning (Luthra et al., 2011). GSCM mainly focuses on returning products and materials in order to forwarding them to recycling, remanufacturing and refurbishing or safe disposal. Consultants recognized that above mentioned problems can be reduced after implementing the new concept of GSCM. But some other problems occurred when implementing the concept of GSCM. Lack of integration of IT systems, cost of implementing and maintaining is comparatively high, lack of green consultants and experts, lack of resources, lack of technical knowledge and experience, lack of adequate environmental measures and uncertainty in competing with the rival manufacturing industries are some problems that have to be overcome while implementing process of the GSCM (Dashore and Sohani, 2021). Those problems should be solved for the maintenance of a successful GSCM process.

After the transmission of TSCM to GSCM organizations and the industries should consider about the impact of TSCM on GSCM and some reasons were recognized by the consultants. Competition with rival industries, reluctance of adapt to the change, fear of failure, unawareness of customers, employees and suppliers, non-availability of bank loans to encourage the green concept, lack of understanding about remanufacturing process and implementing the efficient materials and wastage management systems are the recognized impact of TSCM on GSCM (Zulkefli, Mahmud and Zainudin, 2019). To overcome these impacts some solutions can be recognized.



Improving the remanufacturing process, financial incentives will encourage the GSCM process, providing proper understanding to the employees, introducing new methods for remanufacturing process, improving the quality of the products, cost effectiveness and efficiency and increasing the market share and the growth in the industry are some proposed solutions to overcome the above mentioned impacts.

With the technological upheaval in 21<sup>st</sup> century; all the problems, barriers and the impacts caused by the GSCM and TSCM were reduced and some vanished and now majority of the industries and the organizations are practicing the concept of GSCM because of its massive advantages to the industry. Practicing GSCM can lead to advantages such as resource utilization decrement, waste decrement, the emission decrement and other advantages gained from the TSCM in an advanced manner.

Finally, if the industries and organizations are capable of practicing GSCM concept, those organizations can compete with rival industries and exist in the market and can achieve the highest position in the industrial arena.

## References

- Aslinda, N. *et al.* (2012) 'GREEN SUPPLY CHAIN MANAGEMENT: A REVIEW AND RESEARCH DIRECTION', 3(1), pp. 1-18. doi: 10.5121/ijmvsc.2012.3101.
- Bhattacharjee, K. (2017) 'Green Supply Chain Management- Challenges and Opportunities', (June).
- Croom, S., Romano, P. and Giannakis, M. (2000) 'Supply chain management: an analytical framework for critical literature review', 6.
- Croxton, K. L. *et al.* (2001) 'The Supply Chain Management Processes', 12(2), pp. 13-36.
- Dashore, K. and Sohani, N. (2021) 'ER ER', 2(4), pp. 2021-2030.
- Fernandes, A. C. *et al.* (2014) 'Literature review of QM and SCM: a perspective of integration', pp. 103-114.
- Giménez, C. *et al.* (no date) 'e-Supply Chain Management: review, implications and directions for future research e-Supply Chain Management: review, implications and directions for future research', pp. 25-27.
- Grozniak, A. and Trkman, P. (2015) 'Current Issues and Challenges of Supply Chain Management URRENT ISSUES AND CHALLENGES OF SUPPLY', 9664. doi: 10.1080/1331677X.2012.11517551.
- Habib, M. (2014) 'Supply Chain Management ( SCM ): Its Future Implications', (September), pp. 238-246.
- Janvier-james, A. M. (2012) 'A New Introduction to Supply Chains and Supply Chain Management: Definitions and Theories Perspective', 5(1), pp. 194-207. doi: 10.5539/ibr.v5n1p194.
- Jayant, A. and Azhar, M. (2014) 'Analysis of the barriers for implementing green supply chain management ( GSCM ) Practices: An Interpretive Structural Modeling ( ISM ) Approach', *Procedia Engineering*. Elsevier B.V., 97, pp. 2157-2166. doi: 10.1016/j.proeng.2014.12.459.
- Luthra, S. *et al.* (2011) 'Barriers to implement green supply chain management in automobile industry using interpretive structural modeling technique-An Indian perspective', (January 2015). doi: 10.3926/jiem.2011.v4n2.p231-257.
- Maryniak, A. (2019) 'Barriers of implementation of pro-environmental activities in supply chains'. doi: 10.2478/mape-2019-0049.
- Muysinaliyev, A. and Aktamov, S. (2014) 'Supply chain management concepts: literature review', 15(6), pp. 60-66.
- Parkhi, S. (2015) 'A Study of Evolution and Future of Supply Chain Management A Study of Evolution and Future of Supply Chain Management', (June).
- Patil, M. (2015) 'Challenges for Supply Chain Management in Today ' s Global Competitive Environment', 7(10), pp. 61-64.
- Rahman, T. *et al.* (2020) 'The Management of Operations Evaluating barriers to implementing green supply chain management: An example

from an emerging economy', *Production Planning & Control*. Taylor & Francis, 31(8), pp. 673–698. doi: 10.1080/09537287.2019.1674939.

Series, I. O. P. C. and Science, M. (2019) 'The driver and barrier of implementation green supply chain management ( GSCM ) in construction projects The driver and barrier of implementation green supply chain management ( GSCM ) in construction projects'. doi: 10.1088/1757-899X/673/1/012045.

Shan, W. and Wang, J. (2018) 'Mapping the Landscape and Evolutions of Green Supply Chain Management'. doi: 10.3390/su10030597.

Stock, J. R., Boyer, S. L. and Harmon, T. (2010a) 'Research Opportunities in Supply Chain Management Research opportunities in supply chain management', (October 2014). doi: 10.1007/s11747-009-0136-2.

Stock, J. R., Boyer, S. L. and Harmon, T. (2010b) 'Research Opportunities in Supply Chain Management Research opportunities in supply chain management', (February). doi: 10.1007/s11747-009-0136-2.

Sulistio, J. and Astuti, T. (2015) 'A structural literature review on models and methods analysis of green supply chain management Abstract', *Procedia Manufacturing*. Elsevier B.V., 4(Iess), pp. 291–299. doi: 10.1016/j.promfg.2015.11.043.

Swanson, D. *et al.* (2018) 'An analysis of supply chain management research by topic'. doi: 10.1108/SCM-05-2017-0166.

Zulkefli, N. S., Mahmud, F. and Zainudin, N. M. (2019) 'A Survey on Green Supply Chain Management ( GSCM ) Challenges in the Malaysian Construction Industry', 2019, pp. 1202–1213. doi: 10.18502/kss.v3i22.5120.

### Author Biographies



HMS Ayeshi is a third year Information Systems undergraduate at General Sir John Kotelawala Defence University.



LBL Senavirathna is fourth year Information Technology undergraduate at General Sir John Kotelawala Defence University. Published two research papers in International Research Conference- 2019 at General Sir John Kotelawala Defence University.



Mr. WMSRB Wijerathne is a probationary lecturer at General Sir John Kotelawala Defence University and a postgraduate in BSc (Hons) Management Information Systems at University College Dublin, Ireland.

## E-commerce Personalization for Local Music Instruments Market in Sri Lanka

AMTN Adasuriy#, WJ Samaraweera and WAAM Wanniarachchi

*Department of Information Technology, Faculty of Computing, General Sir John Kotelawala Defence University, Ratmalana, Sri Lanka*

#tharukshinadeera518@gmail.com

**Abstract:** The internet is the most important part of all the people who are living around the world because they can search anything through the internet, and it gives many kinds of conveniences to human lives. Ecommerce web applications are one of the most important technology for information, services, buying items, and selling items over the Internet today. So, it is a more powerful technology in the modern world rather than traditional commerce. The main objective of this research paper is to point out the difficulties of a small-scale business (local musical instruments business) and give a technical solution to maximize their profit and business opportunities. Under this research has been identified the major problems of that business and this is a little effort to develop their business with the concept of personalization which can be used as a business strategy. The personalization aims at satisfying the customer needs and it provides original and innovative research on business information systems. The customized market and product categories provide a comprehensive investigation of the business processes to receive the maximum output of the business. Hence, this solution may be a huge advantage to bloom the local music instruments industry in Sri Lanka.

**Keywords:** Internet, E-Commerce, Personalization

### Introduction

E-commerce, also known as internet commerce or electronic commerce, means the purchase and sale of goods and services that use the Internet and the transfer of data and money to perform the transactions. It is often used to sell different types of physical products over the Internet. Also, it describes any type of commercial transaction which is facilitated by the Internet. During this period, the thought of living without e-commerce seems very complicated. There are thousands of new technologies and innovations that are entering the Internet market every day. Here, the research helps to solve the problems of a musical instruments shop in Piliyandala, Sri Lanka (Sri Sarasavi Musical Instruments Piliyandala) which can be defined as a small-scale business. Hence the main objective is to give an e-commerce-based solution for their major problems and major impacts that were found during the research. Sri Sarasavi Musical Instruments Shop is the only local musical instrument shop located in the Piliyandala area. And also, it is one of the best local music instruments shops in Sri Lanka which designs high-quality musical instruments. It was found that they have well experienced

best drum designers who do a great job for the enhancement of the Sri Lankan music industry. The main challenges are that they often have limited resources in respect of stores (space constraints), raw materials, time, and finances. Ecommerce is the most suitable solution for their major problems

because it helps to reduce the operational costs and costs of running the business. Today musical instruments and the supply industry is at a major turning point. With the emergence of the Internet and its accessibility, the music business has grown exponentially. Some of the expected benefits from e-commerce in the music businesses are integrated into business cycles, improved customer interactions, larger purchases per transaction, a larger number of buyers, a larger number of vendors, and lower transaction costs of doing businesses. The purchasing decisions in the music industry are based on people's feelings and passion. Therefore, people seek special research and advice before purchasing many instruments.

The most successful e-commerce businesses do not optimize every single metric available. The personalization is a particular metric in e-commerce right now. It can be defined as the proactive of creating personal interactions based on the experiences of e-commerce sites. Hence the concept of personalization has been used here to customers feel special and improve their purchasing experiences.

## Literature Review

### A. E-commerce and music industry

E-commerce is becoming a blossoming research field because of IT infrastructure, mobile communication, and high penetration of the internet. It is a peaceful investment for businesses, where growth is expected to increase as the overall market grows. E-commerce is mainly related to the online transactions of buying and selling goods and services. Today different types of applications are available and there is no time or a geographic scope limitation.<sup>[1]</sup> It has become a major part of all types of business scenarios and it has been adopted by nearly all industries.<sup>[1]</sup> There are so many indications happening in the music industry in different countries because of e-commerce

technology.<sup>[2]</sup> As an example, the United States of America is a top country that use e-commerce technology to grow the music industry and many consumers buy different types of music items and services via e-commerce websites.<sup>[2]</sup> Under this research that one of the main targets applies the e-commerce concepts and technology to build up the local music industry in Sri Lanka with high-quality products though it is a small scale business.

### B. Small scale businesses and online marketplace

The field of small businesses has a huge impact on the economy of a country especially in a developing country like Sri Lanka.<sup>[3]</sup> Because a small scale industry is a very important part of the industrial background of a country and it may cause to employment generator segment of the economy.<sup>[4]</sup> It can be considered as the backbone of the economy in all the countries.<sup>[4]</sup> The online marketplace initially levelled the playing field for small-scale businesses and it has succeeded in creating an environment whereby social recommendations can impact customer choices whilst remaining relatively anonymous.<sup>[5]</sup> Also, the e-commerce lowers transaction costs that formerly served as a barrier to entry in local markets. It enables consumers to become aware of and transact with electronic retailers who may be located anywhere in the world.<sup>[5]</sup> E-commerce is getting all the more broadly open and less expensive to work.

### C. E-commerce Personalization

E-commerce websites personalize customer experience to encourage them to purchase goods and services from different platforms as they prefer.<sup>[6]</sup> Its mission is to enhance the shopping experience of users by adapting the visual and interactive design features of e-commerce web environments based on user cognitive processing features.<sup>[7]</sup> There are

several benefits to using personalization methods for e-commerce systems. [6] Research has shown that concept plays an important role in how people use technology and in the persuasion strategies they prefer. [6] For example, such a system can learn from a customer and recommend personalized products that the customer may want. Because of more and more product information being posted online, the excessive amount of information now makes it difficult for consumers to make their choices. [8] Consumers may feel lost when they search for large product information available and may be turned away from the business. [8] Therefore, it is necessary to filter the information and present it to suit the preferences of the customer. [8] This process is known as e-commerce personalization. [8] With the increasing use of e-commerce on the Internet, personalization is becoming more important. [8] In the context of this paper, personalization is the ability of the system to automatically meet the various needs and interests of customers. Recommendation systems are having much commercial success in the business world and are becoming increasingly popular in a variety of practical applications. [9] For example, online stores such as iTunes, Amazon, and e-bay provide customized recommendations for additional products or services and are based on consumer behaviours. [9]

E-commerce is giving access to a worldwide audience and web developers have been devising new techniques and methods to enable e-commerce websites to purchase commercial advantages. [5] Search Engine Optimisation processes, and customize email sending, strategically placed adverts, and strong connections between chains of businesses. [5] The purpose of personalization is to promote and classify the tastes of each viewer. There are two main approaches to personalized recommendations such as a

content-based approach and a collaborative filtering approach. [10] In a content-based approach, it recommends items that the user would like in the past. In the collaborative filter approach, it identifies other users who have shown a similar preference for a given user and recommends what they like. [10]

Data mining has recently become an important area for personalization and it focuses on techniques for previously unknown, and useful information from a large amount of data. [10] As businesses used computers to store data, data mining technology began to evolve as a new approach to assisting navigation through the database. [11] Its purpose is to help businesses focus on important and useful information by extracting hidden forecast information from large databases. [10] [11] Data analysis is carried out by using the most appropriate statistical methods techniques which are helped to present qualitative data in a more meaningful way. [6]

## Methodology

### A. Data Collection

To explore whether local merchants are trying to understand the correlation between physical and online existence, we conducted an exploratory study of local businesses that have set up websites. And also, it is required to get permission from the owner since it is a problem regarding a real business. Hence, permission has been taken from the owner to develop the e-commerce personalization system to give solutions for the existing problems. Details about the current situation of the business were gathered by having meetings and discussions with the owner

and customer feedbacks was also considered. To gather the major requirements, open interviews were carried out with the owner and another employee of the business. And also, carried out the customer behaviours and pre-transaction details which can be recognized as sales of the business. Furthermore, customer requirements were also noted by having open-ended interviews with them. Apart from the open-ended interviews, simple questionnaires are planned to be prepared for the customers. The questionnaires were in a very simple way so that people can understand it very easily. By which that some more information regarding the business were collected.

### B. Results

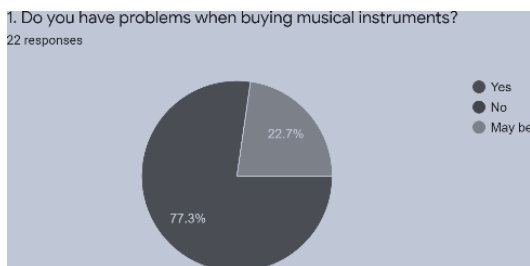

Figure 1. Problems when buying instruments



Figure 2. Products availability when buying instruments

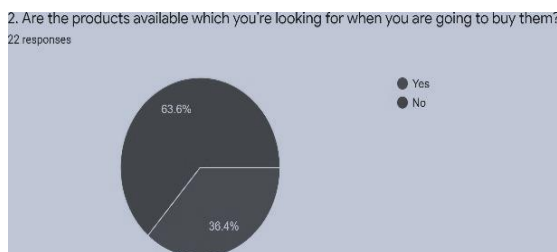

Figure 3. The satisfaction of the current system

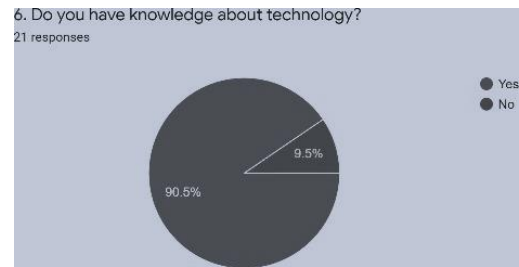

Figure 4. Willingness to use e-commerce applications

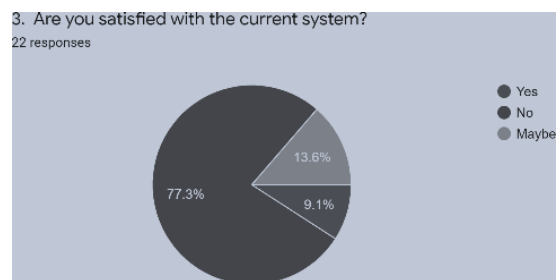

Figure 5. Willingness to compare instruments prices

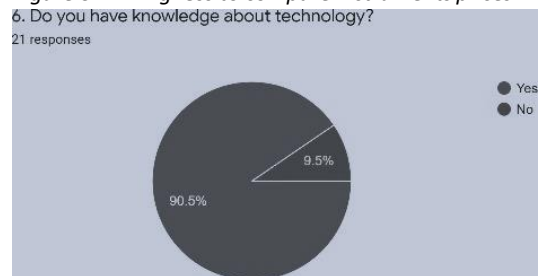

Figure 6. Knowledge of technology

Above mentioned survey results show that implementing such an e-commerce system is necessary for the improvement of the current situation of the system & shows that there are no technology barriers to implement. Through the statistics of this survey could get an overall idea about what customers think & which parts should be automated using this solution.

#### A. Analyzing the system

When designing the user interfaces of the system, it is expected to be designed in a very user-friendly manner. Since everyone is not with equal technical knowledge it has planned with simple interfaces. User's ideas have highly considered when deciding the colours for the interfaces. After requirements have been gathered and architectural design has been fixed, structuring the software began. At the

development stage should be concerning the security feedback is a major requirement. The implementation stage is the most important part which integrates the software with good services and components with the best workflow according to the organizational structure and end-user requirements. Especially the system is designed to avoid difficulties in supplying musical instruments to schools and institutes. As a solution regards the problems, they will be able to request orders and tenders through the system as well as print the documents via a pdf file. There are two types of customer accounts in the system such as personal and business which depend on the way they are requesting orders. Hence the customers can register with the system as a business account if they buy many instruments at once or need tenders. Another best opportunity is that the vendors can be registered to the system and request the orders to supply the raw materials and instruments for the business which has been found as a major problem in the local music industry. The system is integrated with social media to get involved in the young generation to enhance the local music industry in Sri Lanka. Hence the system has an active social media interrelationship where users ask and answer specific questions about the business and their products. On the business side, the administrator/owner of the business having the ability to maintain all customer details, vendor details, product details as well as category details. As a personalized system, it displays the most related instrument for the consumers by considering the previous preferences and send customize e-mails according to the previous search history because it is necessary to filter the information and present it to suit the preferences of the customer.

The personalized e-commerce web application will be prepared according to the

agile software development methodology which is one of the best software development methods. Agile methodology is a project management process primarily used for software development, where demands and solutions evolve through the collaborative efforts of self-organizations and cross-action groups and their clients.

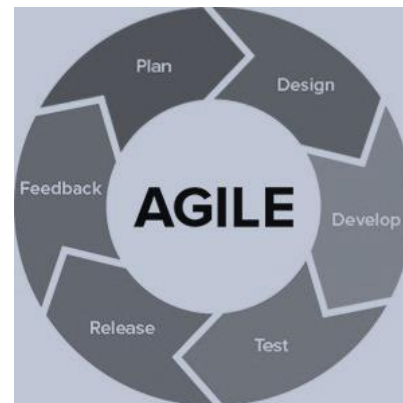

Figure 7. Agile Methodology

#### A. Data mining and personalization

After user categorization, the personalization module adapts meaningfully enriched content while running on the client-side. Various data extraction methods can be used to improve personalized systems such as clustering, association, classification, and similarity indexing. Clustering and similarity indexing methods can be used as a means to identify or group peer groups or content groups. Under the research has been identified the background of the population as school marchbands/orchestra, professionals, and music institutions in Sri Lanka. Association rules can be used to identify products that are often bought together for cross-selling. It can also be generalized to identify customer bias for target promotion. Classification is another medium for target promotion or categorization. Here we will consider a concept that is more related to the concept of association rule which is originally proposed in the context of supermarket data to study the relationship of customer buying patterns in transaction data. Four major instrument

categories have been identified such as Udarata, Pahatharata, Sabaragamuwa, and Traditional. Each instrument comes under those categories and it is the most effective way to generalize customer bias and identify products. The personalized e-commerce will be supported to the customers in achieving their primary objectives or goals. To assess the personalization of the personalized e-commerce web application, we use the Framework for e-Commerce personalization enhanced by Captain and Pervinen. [12] We use this model because it is the only framework in which privatization is evaluated in e-commerce. The model demonstrates that there are several requirements for the success of personalization and that they fall into two main categories: Consumer Behaviour and Technology Needs. If the three requirements are related to customer behaviours; 1) The personalized content presented to a user should have an impact on business returns. 2) The impact should be different for each customer - it should be heterogeneous. 3) The effect should be largely stable. Technology-related requirements, on the other hand, consist of technology implemented by an e-business to tailor content to specific users. These requirements are 1) the ability to measure the impact of personalization, 2) the ability to manipulate content, and 3) the ability to scale the algorithm used for personalization.

In this study, we only evaluate the requirements regarding customer behaviours by considering their purchase history. The suggestion principle asserts that users are expected to achieve their target behaviours if the system offers suggestions while in use.

When considering the customer behaviours, it seems to be that January, July, and December are the most profitable periods for the business and the system will be able to recommend particular items for the regular

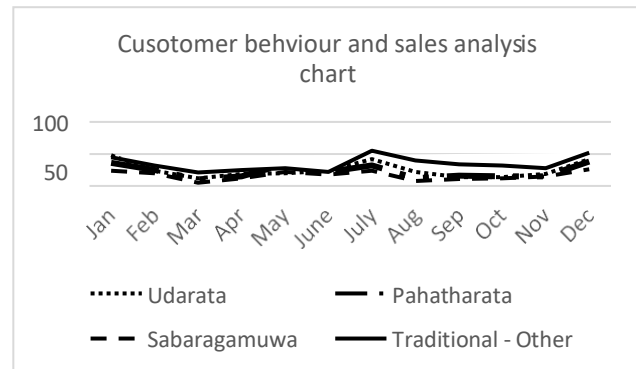

Figure 8 Customer behaviour and sales chart

customers as they prefer. For that here we will use the techniques of customizing e-mail sending as well as customize a search bar that offers suggestions while typing the product name in the search bar. It allows customers to search for product information, compare prices and benefits, and assess its value before making a purchase.

### Conclusion and future works

E-commerce web applications are a very important technology for information, services, buying goods, and selling goods online. Electronic commerce and the Internet integrate both the service and goods sectors across local and international boundaries. To explore whether local traders are trying to understand the correlation between physical and online existence, we did an exploratory study of local music instruments businesses and small businesses. Customized market and product categories provide extensive scrutiny of business processes to maximize business output. So, this system is the major component that is introduced to maximize the profit of the Sri Sarasavi Musical Instruments Shop Piliyandala, Sri Lanka. The benefit of this system is not only to its owner and employees but also for the customers and other businesses too. The main purpose of developing the personalization e-commerce system is that customers can check the availability of the instruments without visiting the shop and they can save their time. Timesaving is one of the important benefits that people can have through e-



commerce technology than traditional commerce concepts. Due to space constraints, the business needs only the minimum amount of goods in storage. A virtual store allows businesses to store many items regardless of the cost of inventory. Long term storage of instruments is not needed as they have displayed all the details of the available instruments in the system because there are no physical marketplaces for the e-commerce transactions and a customer can request the needed instruments through the system. The business owners are well satisfied with the system and giving a maximum contribution to developing the application. The major task is they need to have an effective training period and proper guidelines to gain the maximum benefits of the system. Anyhow some possible barriers prevent introducing an e-commerce application because some instrumentalists never buy non-electronic instruments online due to the inability of testing the acoustic and build quality. In this study, we only evaluate the requirements regarding customer behaviours as these can be inferred from the system. In the future, we intend to further assess technology as a necessity.

## References

- Chihlee University of Technology, Y.-J. Yang, C.-C. Wang, National Taipei University, C.-C. Chen, and Tamkang University, 'Recent Development Trend of Electronic Commerce Research: 2000 to 2016', *Contemp. Manag. Res.*, vol. 13, no. 2, pp. 131–142, Jun. 2017, doi: 10.7903/cmr.17824.
- M. Fox, 'E-commerce Business Models for the Music Industry', *Pop. Music Soc.*, vol. 27, no. 2, pp. 201–220, Mar. 2004, doi: 10.1080/03007760410001685831.
- C. J. Brown, 'Small Business Innovation Management', p. 14.
- R. Kumar, 'Marketing Strategies of Small and Medium Enterprises: A Sample Survey', vol. 01, no. 02, p. 13, 2012.
- S. Thomas, 'Mutually Beneficial Publisher and Artist Regulated Distribution Model for the Niche Music Industry', p. 15.
- M. Nkwo, R. Orji, J. Nwokeji, and C. Ndulue, 'E-Commerce Personalization in Africa: A Comparative Analysis of Jumia and Konga', p. 10.
- M. Belk, P. Germanakos, P. Andreou, and G. Samaras, 'Towards a Human-Centered E-Commerce Personalization Framework', in 2015 IEEE/WIC/ACM International Conference on Web Intelligence and Intelligent Agent Technology (WI-IAT), Singapore, Singapore, Dec. 2015, pp. 357–360, doi: 10.1109/WI-IAT.2015.204.
- K. W. Wong, C. C. Fung, and H. Eren, 'Soft Computing Techniques for Product Filtering in E-commerce Personalisation: A Comparison Study', *Rd IEEE Int. Conf. Digit. Ecosyst. Technol.*, p. 5, 2009.
- Q. Zhao, Y. Zhang, D. Friedman, and F. Tan, 'E-commerce Recommendation with Personalized Promotion', in *Proceedings of the 9th ACM Conference on Recommender Systems - RecSys '15*, Vienna, Austria, 2015, pp. 219–226, doi: 10.1145/2792838.2800178.
- P. S. Yu, 'Data mining and personalization technologies', in *Proceedings. 6th International Conference on Advanced Systems for Advanced Applications*, Hsinchu, Taiwan, 1999, pp. 6–13, doi: 10.1109/DASFAA.1999.765731.
- Kok Wai Wong, Chun Che Fung, T. Gedeon, and D. Chai, 'Intelligent data mining and personalization for customer relationship management', in *ICARCV 2004 8th Control, Automation, Robotics, and Vision Conference*, 2004., Kunming, China, 2004, vol. 3, pp. 1796–1801, doi: 10.1109/ICARCV.2004.1469431.
- A. Goy, L. Ardissono, and G. Petrone, 'Personalization in E-Commerce Applications', in *The Adaptive Web*, vol. 4321, P. Brusilovsky, A. Kobsa, and W. Nejdl, Eds. Berlin, Heidelberg: Springer Berlin Heidelberg, 2007, pp. 485–520.

## Automated Hospital Clinic Maintaining System for Government Hospitals in Sri Lanka

GRM Gunarathne# and IA Wijethunga

*General Sir John Kotelawala Defence University, Sri Lanka*

# ravindumiyuranga@gmail.com

**Abstract:** The healthcare system is the most important factor in the development of the country. When considering healthcare hospitals contribution is priceless. So, in Sri Lanka, there are two types of hospitals. Such as government hospitals and private hospitals. Most of the people in this country use government hospitals for their treatment. Treatments to agelong diseases for long-term is one aspect of the treatment. To treat these agelong diseases hospitals, conduct the clinics. That clinics are divides based on the majority of the disease type. This research-based on the difficulties of the existing manual hospital clinic management system and the way it upgraded to the automated computerized system. The methodology used to conduct this research is a qualitative and quantitative-based survey. The online survey circulated through Email and the survey were completed by 300 samples of people covering the western province of Sri Lanka

**Keywords:** Manual, Automated, Clinics

### Introduction

Hospitals play a vital role in Sri Lankan healthcare services. Great healthcare service is necessary for any nation in the world. Because of the efficient healthcare service system hold the key of development of the country. Increased diversity and specialization are the main problems posed in healthcare today. New medical specialties are continually being created: there are many positions in patient care, as well as many public and private organizations. All of these positions are involved in the treatment

of a single patient in health care organizations. Hospitals are the backbone of the health service.

In Sri Lanka healthcare service has various aspects. Among all of these aspects' hospitals play a vital role in healthcare service. Also, hospitals are the backbone of the healthcare service. Sri Lankan healthcare service have two types of hospitals. Such as government hospitals and private hospitals. Perspective difference of this partitioning is from the government hospitals patient can get medicine for their diseases free of charge and from the private hospital's patients can get their medicine for their disease's payment basis.

These government hospitals have many aspects for give treatments to patients. Such as hospitals Out-Patient department (OPD), residential patient caring and hospital clinics, etc. When consider about hospital clinic, government hospitals conduct these hospital clinics for cure to patients' long-term for their agelong diseases.

Patients are categories to these clinics, depending on the type of disease. Through these clinics, patients can get treatments to their agelong diseases. That treatments can be day to day, weekly or monthly. It depends on the nature of the diseases. In the current hospital clinic system one hospital have one or more clinics. These clinics divided based on the major aspect of the human diseases. When a patient attends Out Patient Department (OPD) to check for a disease if that patient has a long-term illness, the hospital's OPD submits a latter request to the

Hospital Clinic Department to register that patient to a particular clinic. Hospital clinics have a manual system for registering new clinic patients and recording the daily status of the patient. This information was usually recorded in books. Sometimes after the patient is dead, they keep that record. Because of these record books may reason for so many problems. Sometimes these record books can damage, lost, patient forget to bring or sometime that record books can be misappropriation. Because of these reasons' doctors cannot identify patient real status, sometimes allergic can be occurs, sometime patient privacy in huge problem or patient can be dead because of some reasons. Sometimes one patient can be registered into one or more clinics. In that case, that patient and hospital clinic must maintain one or more separate clinics record books. Because of that kind of incident data redundancy can be occurred.

### **Literature Review**

This research-based on a survey of the difficulties of the existing hospital clinic management system and the way to upgrade the existing system to automated computerized hospital clinic management system.

More and more government agencies, businesses and healthcare organizations are moving nowadays towards electronic records from paper records. Electronic Medical Record (EMR) system is used in healthcare organizations to capture, organize, maintain and retrieve medical records of patients. EMR program is a comprehensive database used to store and manage health care records for patients. For all scientific, regulatory or organizational needs, the EMR has substituted traditional paper medical records as the sole source of information in healthcare services. The paper aims to review the existing Electronic Records Management Systems (ERMS) and evaluate the healthcare industry impact of

EMR systems. (Edmund, Ramaiah and Gulla, 2009)

This research introduces an innovative real-time system to enhance clinical research and analysis, which will enable access to medical information and promote care. Many issues remain in the hospital today, such as medical records of lost patients and other critical documents, this paper will address these issues. The system will help replace the manual procedure, and speed up information processing, storage and retrieval, which will greatly assist medical staff in performing their duties. Owing to increased productivity and overall efficiency, hospitals would benefit above all from relentless cost savings. (Ilo, Abraham and C, 2015)

The Hospital Clinic Maintaining System of the Doctor's aspect is concerned with the efforts to keep patient records and monitor their status. For a fact, the doctor's office holds the data of his patients. (Mamra et al., 2017)

Innovative automated hospital clinic maintaining system is based client-server architecture. The client-server architecture is a distributed computing between two types of autonomous and independent entities known as the server and client. Functions such as websites, web-based applications, a centralized computing system, mobile apps, e-commerce applications or even cloud computing are subsidized with the client-server concept in the modern information technology environment. Client-server computing places a crucial role among the majority in the form of remotely stored lactation for data or information access. The client-server system plays an important part in the evolution of IT. The client-server system components divided into two major sections of physical and logical components. Physical components are servers, client devices, input/output devices, networking, and power supply. Logical components are web pages, data, programming scripts, protocols,

e.g., http, https, telnet, IP and API, e.g., ODBC, JDBC. (Mohanty et al., 2019)

Middle-ware systems designed to increase distributed machine efficiency. Residing between the operating system and distributed applications, middle-ware systems provide abstractions that hide from application developers several details inherent to distributed programming, such as network communication primitives, failure handling, heterogeneity, service lookup and synchronization. The most common middle-ware platforms include Java RMI. In such systems, developers use the same syntax of local invocations to invoke methods on remote objects; thus, code for handling distributed communication looks similar to code that handles communication in centralized systems. (Pereira et al., 2004)

For security purposes, bar-coded ID Cards are used. When we use a client-server architecture to enforce this strategy it becomes a simple security version. In theory, barcodes are the encrypted type of data. Information that has to be stored in barcode type depends on the organization. The choices for the encrypted barcode could be rendered by proper software packages. I plan to use the creation of a very compact database kit that handles barcode printing using the NIC number with some encryption keys. (Ahmed, Haider and Nadeem, 2010)

An innovative registry definition which covers both the physician and patient information. It is a kind of database that includes the record keeping of the patient. Its principle avoids record manipulating operation. There are risks that the important data may be destroyed, but we can preserve a backup of each and every data by using this principle. The software is also protected in every way. This will make the data accessible to everyone in a decentralized way. Each person will have their own unique ID and PASSWORD. The registration form of the patient will also be maintained, including his

/ her name, address, contact number, date of birth, etc. The information will be moved from clinic to clinic and each client will have access to only their own personal data. (Yadav et al., 2016)

In increasingly everyday situations we come across conversational algorithms or chat-bots more and more frequently. For example, purchasing a flight ticket, or clothing from an e-shop. As an advanced and effectively implemented AI, chat-bots have their recognizably history and logical framework for development. (ZEMČÍK, 2019)

There are a variety of treatments available for different diseases. Possibly no person would know all the drugs and the diseases. So, the problem is there is no place where anyone can get the specifics of the diseases or the medicines. The AI can predict the symptom-based diseases and provide a list of treatments available. The system can also give the medicines composition and the uses prescribed for them. (Madhu et al., 2017)

Medical chat-bot using Artificial Intelligence which can diagnose the disease before consulting a doctor. The medical chat-bot is built to reduce the healthcare costs and increase accessibility to medical knowledge. Some chat-bots act as medical reference books that help the patient learn more about their illness and help improve their health. The user can only achieve a chat-bot's real benefit if he can diagnose all sorts of illness and provide the necessary information. A text-to-text diagnostic bot involves patients talking about their medical problems and provides a personalized diagnosis based on their symptoms. People will therefore have an idea of their health, and they will have the right protection. (Divya et al., 2018)

### **Methodology**

The aims of this research area to explore the regression of the existing system for maintaining hospital clinic. The main objectives of this research were to upgrade

existing systems to the automated and computerized hospital clinic maintaining system. We used non-probability sampling methods for this research based on quantitative and qualitative data.

#### A. Collection of Sample

There are many government clinic users in this research. The population was large. Since this issue, this research was selected as a non-random sampling method for selecting the sample. Because the method of obtaining data was very cheaper and quicker. To increase data accuracy, Sri Lankan citizens have been categorized into a population only for the western province.

#### B. Collection of Data

In this research, the survey data were collected by a questionnaire. This online survey was performed by e-mail. We have also conducted several interviewees in addition to these questionnaires to improve the quality of the results of this research.

We have attempted to determine several specific facts through this questionnaire. Such as issues when registering for clinics, maintaining the clinic record books, the difficulty of select the next clinic date and medical details misappropriation. And, with a few open-ended questions, this questionnaire contained dichotomous questions, checklist questions.

### Results and Discussion

Sri Lanka is a developing country. When considering health care system hospitals done a major thing to help the development of the country. But in government hospitals, most of the aspects work on a manual system. Hospital clinic maintaining system takes apart in that manual system. Because of this existing manual system be a major reason for many problems. This research focusses to find the barriers to the existing system and find a way to upgrade the existing manual

system to an automated computerized system.

#### Questions of chosen specimens

The questionnaire circulated was based on close-ended questions. We gave optional open-ended questions for further evaluation and research assistance.

#### 1) Section 1: Social and Demographic data:

- Gender

*Table 1. Gender popularity as a percentage*

Particulars	No. of Respondents	Percentage
Male	140	46.7%
Female	160	53.3%
Total	300	100%

Analysis and Interpretation: As shown in Table 1 of the 300 specimens that participated in the research Female was the plurality of 53.3% and Male was 46.7%.

- Age

*Table 2. Age popularity as a percentage*

Particulars	Percentage
Under 12 years old.	1.2%
12 - 17 years old.	10.3%
18 - 24 years old.	18.6%
25 - 34 years old.	26.7%
35 - 44 years old.	21.6%
45 - 54 years old.	19.6%
55 years old or above.	2.0%

Analysis and Interpretation: Table 2 shows the samples listed by age. The bulk of patients in hospital clinic range from 25-34 years and the minority of patients in hospital clinic range from below 12 years.

- Most used hospital types

Analysis and Interpretation: Table 2 shows the samples listed by the usage of government and private hospitals. Majority of using private hospitals 36% and minor government hospital 36%. 16% used both services. such as government and private hospitals.

Table 3. Hospital using popularity as a percentage

Particulars	Percentage
Web-based	33.3%
Mobile application	83.3%

- Attending of government hospital clinics

Table 4. Hospital clinic using popularity as a percentage

Particulars	Percentage
Yes	43.3%
No	56.7%

Analysis and Interpretation: As shown in Table 4 minority of 43.3% used or currently using hospital clinic and majority of 56.7% never used hospital clinic facility.

2) Section 2: Extant System:

- Current hospital clinic system

Table 5. Current type of hospital clinic system

Particulars	Percentage
Manual	16.7%
Automated	83.3%

Analysis and Interpretation: As shown in Table 5 majority of 83.3% used manual system for hospital clinics and minority of 16.7% using automated hospital clinic maintaining system.

- Satisfaction of existing manual system.

Table 6. Satisfaction of existing manual system

Particulars	Percentage
Strongly satisfy	3.3%
Satisfy	20%
Neutral	26.7%
Dissatisfy	46.7%
Strongly dissatisfy	3.3%
Easy GUI guiding	43.3%
Self reset login details	30%
Instant SMS and Email alerts	63.3%
Easy to access previous clinic records	53.3%
Easy to pick a channelling number for next channel date	46.7%

Analysis and Interpretation: Table 5 shows the samples listed by satisfaction of the existing system. The bulk of patients in hospital clinic dissatisfy with the existing manual hospital clinic maintaining system.

• Difficulties

Table 7. Difficulties of the existing hospital clinic system (Multiple Answers)

Particulars	Percentage
Registering for new clinics	60%
Maintaining separate clinic record book for each clinic	50%
Every clinic day bring the clinic record book	46.7%
Forget to bring clinic record book	50%
Damage or lost clinic record book	46.7%
Clinic record book or your medical information misappropriation	36.7%

Analysis and Interpretation: Table 7 show the difficulties of the existing system. Most patients face with the registration problems.

- Platform popularity for Automated hospital clinic maintaining system

Particulars	Percentage
Government	36%
Private	48%
Both	16%

Table 8. Platform usage as a percentage (Multiple Answers)

Analysis and Interpretation: As shown in Table 8 most of clinic patients prefer to use the service through a mobile application and next, they prefer web-based application.

- Features add to the new automated system

Table 9. Features that prefer to add to new automated system as a percentage (Multiple Answers)

Analysis and Interpretation: Table 9 shows hospital clinic patients ' expectations from a new system. They mostly try to avoid the problems identified in Table 7.

**Conclusion**

As a developing country, we must go forward with technology. Based on that all government sector manual systems must be

computerized and automated. According to that government hospital management system must be automated. This research-based on only one aspect of the government hospital system. So, in this research only focus on to hospital clinic maintenance system. As our research, most of the government hospital clinics in the western province used manual systems for day-to-day works. Usually, one hospital has two or more clinics. Some hospitals have more than 15 clinics. If some patients register to two or more clinics that patient has to maintain clinic record books according to the number of clinics that patients registered. It can be a reason for so many problems because of the manual system. So many people are dissatisfied with the existing manual system according to our research. People really want to upgrade existing system to automated and computerized system. Many people usually receive medication from the private hospital, according to the research. Other than that, the satisfaction of the existing system. Because of some major problems with the existing system most people dissatisfy with the existing system. The upgraded automated system must have automated alerts for the next clinic session, simple-to-understand GUI, use Sinhalese as the default language and it must be easy to use for elderly people who do not have IT skills, usually a lot of time is wasted due to lack of proper management, hence, it must be assigned to a proper time management system to be successful, usually a lot of time is wasted due to lack of proper management.

## References

- Ahmed, S. S., Haider, U. and Nadeem, A. (2010) 'Client/server model of security with bar-coded identity cards', Proceedings - 2010 3rd IEEE International Conference on Computer Science and Information Technology, ICCSIT 2010, 9(July 2010), pp. 687-691. doi: 10.1109/ICCSIT.2010.5565129.
- Divya, S. et al. (2018) 'A Self-Diagnosis Medical Chatbot Using Artificial Intelligence', Journal of Web Development and Web Designing, 3(1), pp. 1-7. Available at: <http://matjournals.in/index.php/JoWDWD/article/view/2334>.
- Edmund, L. C. S., Ramaiah, C. K. and Gulla, S. P. (2009) 'Electronic Medical Records Management Systems: An Overview', DESIDOC Journal of Library & Information Technology, 29(6), pp. 3-12. doi: 10.14429/djlit.29.273.
- Ilo, S. F., Abraham, I. and C, A. J. (2015) 'Designing A Web Based Hospital Management System For MOUAU Clinic', International Journal of Trend in Research and Development, 2(6), pp. 286-293. Available at: [www.ijtrd.com](http://www.ijtrd.com).
- Madhu, D. et al. (2017) 'A novel approach for medical assistance using trained chatbot', Proceedings of the International Conference on Inventive Communication and Computational Technologies, ICICCT 2017, (Icicct), pp. 243-246. doi: 10.1109/ICICCT.2017.7975195.
- Mamra, A. et al. (2017) 'A Proposed Framework to Investigate the User Acceptance of Personal Health Records in Malaysia using UTAUT2 and PMT', International Journal of Advanced Computer Science and Applications, 8(3), pp. 386-392. doi: 10.14569/ijacsa.2017.080353.
- Mohanty, S. et al. (2019) 'What lessons India must learn from Physical Activity promotion models?: An Integrative review of 2 successful Models', International Journal of Recent Scientific Research, 10(5), pp. 32535-39. doi: 10.24327/IJRSR.
- Pereira, F. M. Q. et al. (2004) 'Tactics for remote method invocation', Journal of Universal Computer Science, 10(7), pp. 824-842. doi: 10.3217/jucs-010-07-0824.
- Yadav, G. et al. (2016) 'Advanced Hospital Database Management System', International Journal of Advanced Research in Computer and Communication Engineering, 5(4), pp. 221-223. doi: 10.17148/IJARCCCE.2016.5456.
- ZEMČÍK, M. T. (2019) 'A Brief History of Chatbots', DEStech Transactions on Computer Science and Engineering, (aicae). doi: 10.12783/dtcse/aicae2019/31439.

## Use of Distance Learning Technologies Efficiently in a Crisis/Pandemic Situation

GGA Ranasinghe, KHNK Kumarasinghe, AHMD Somasiri, RT Wehella, RPS Kathriarachchi

*Department of Information Technology, Faculty of Computing, General Sir John Kotelawala Defence University, Ratmalana, Sri Lanka.*

anuparanasinghe998@gmail.com

**Abstract:** Due to the outbreak of the COVID-19 pandemic situation in the world distance learning is playing a huge role in the education sector. Several shortcomings could be seen in this method since it was started as an alternative. This survey involved both students and teachers in Sri Lanka. Altogether the survey was passed to 300 individuals and 234 successful responses were grabbed within a week. The survey helped to identify the shortcomings and barriers to effectively conduct distance learning in Sri Lanka. The lack of enough advisors online, marketing advantages, lack of physical facilities to go online for the students and teacher, non-readiness of teachers and parents for the change etc. The paper allows to sort out the identified problem and form a set of guidelines on how to use distance learning hereafter in a pandemic/crisis by overcoming the shortcomings.

**Keywords:** Distance Learning, Online Educational Management, Covid-19 pandemic

### Introduction

Learning is the process of acquiring new understanding, knowledge, behaviour, skills, values, and preferences. The act of learning drives down to a deep past in the human history. The man has evolved to a state of learning through the internet at present. Most of the tasks in the world today are done online considering about the convenience of the people. There are several online learning methodologies for example Asynchronous

Online Courses, Synchronous Online Courses, Hybrid or Blended Online Courses etc. Online learning is also referred to as e-learning among other terms. Online learning is just one type of “distance learning”.

Distance learning also has taken a major role on human day today lives. Many students and teachers are not able to interact with each other without meeting physically hence they are connected virtually through computers and the internet. Various educational platforms and learning management systems provide the opportunity for distance learning. Distance learning plays a major role in today’s world after the breaking out of the COVID-19 virus back in 2019. Due to the lockdowns and curfew situation in many nations around the world all industries and work environments are facing a crisis carrying out their work. This has affected the educational sector as well. In this kind of situation Distance Learning plays a major role to carry out the educational practices around the world. Online working platforms such as Learning Management Systems,

Live classrooms are used to connect students and teachers for communication and interaction. Students have also tended to do self-study using the internet to further develop their knowledge.

Online communication platforms such as ZOOM Meetings, CISCO WebEx Meetings, Google Meet etc. are in action to provide an environment for the students and teachers to carry Distance Learning. People around the world tend to find newer ways to conduct



Distance Learning so that the involvement of students will be higher than average. The main expectation of Distance Learning techniques is to increase the quality of the learning and teaching in the education system. The contribution of this study is to review the challenges and opportunities in Distance Learning under the prevailing pandemic situation and to produce a framework which will overcome the challenges related to Distance Learning.

### Literature Review

E-Learning is defined as “The process of learning online through internet”. A case study of a Higher Educational Institute for three months has offered support for the proposition that measurable improvements can be made in the design delivery of online program. The design delivery can be improved by upgrading or enhancing technologies like communication , video conferencing, electronic portfolio, discussion forums and developing an effective plan with quality materials. (Xu, 2007)

Most Egyptian universities face many problems in traditional learning and the Moodle is the only eLearning method most of them has used. Moodle can be used in delivering e-content and to provide possibilities for implementing e-learning web-based modules. This research contains on facts to improve student motivation within e-learning and because of the lack of personal contact between and the instructor it is a bit difficult. To avoid this instructor can perform intime assessments, assignments and quizzes. Like wise use of the interactive features of e-learning increases the motivation of undergraduates for a better learning process. (El-seoud et al., 2009)

Frequencies of distance education notions means and standard deviations for statements, T-test and One-way Anova analyses has performed using two universities in Turkey. Females, vocational

high school graduates and full-time working students agree with this online learning statements more than others do. Probably it may be because of students are satisfied with the education system which provides great convince in time and cost. The deficiencies and defective points of distance education are also determined. Accounting instructors should offer more opportunities for meaningful dialogues by the use of modern updated multimedia technologies. (Angay and Gulmez, 2012)

Distance learning has great potential to set a high standard for valuable learning experiences in virtual environments. Identified the main barriers to the effective implementation of modern distance learning technologies in the university teaching and learning process. Non-readiness of teachers and parents, the lack of necessary skills of applying the computer-based online learning systems, inability to interact with the faculty and teachers, the lack of sufficient academic advisors online. (Leontyeva, 2018)

Most studies have investigated students' qualities in Distance Learning and found that specific attributes lend to a superior distance learner. This study researched students' self-efficacy convictions of Distance Learning, achievements in Distance Learning, and the relations to students' attributes. Distance Learning self-efficacy, SRL skills, and registering abilities were end up being the significant indicators of students' general accomplishments in Distance Learning. Significant gender contrasts were seen on both Distance Learning self-efficacy and Distance Learning attainment. All the elements should be considered to structure steady, adaptive, and powerful Distance Learning systems. (Distance et al., 2001)

Representing of the primary examination directed in Italy at college level to distinguish the impacts initiated on students by the trade of the educational processes from physical to completely virtual, brought about by the

Coronavirus epidemic. Results appeared as, although students appear to miss and avoid physical settings and face to face activities, the transitory change from physical to completely virtual setting has been decidedly retained. The general rising situation demonstrates that an enormous part of the present generation of university students is prepared for novel instructive procedures, to a great extent grounded on blended learning activities. (Giovannella, 2020)

Distance learning definition includes technologies, opportunities, challenges, concepts, and contributions as it is becoming an essential part of the day to day life and in the educational systems in both developed and developing countries. Using new technologies to ways of teaching new knowledge is not confined by space and time anymore. virtual economy is one of the main reasons for globalization and economic networking. Education is important for every child in his world, to improve knowledge and to change the world into a better place. Because of geographical distances, developing, and unavailability of technologies many the world's populations is uneducated. (Bušelić, 2012)

Education can become groundbreaking when instructors and students integrate data across subjects. weigh altogether alternate points of view, and fuse different requests. Teachers can build such prospects by cultivating basic learning spaces, in which understudies are urged to expand their abilities of examination, creative mind, basic blend, imaginative articulation, mindfulness, and deliberateness. Eeffective online education is based on well-designed course content, good communication between the teacher and students, supportive teachers. (Sun and Chen, 2016)

Higher education difficulties, for example, required educational roads or the institutional set facing the interest of the populace, accomplishments in worldwide

learning, giving space to rise to access to learning, research on money-saving advantage examination, educational advancements, and association, utilization of educational innovation, quality assurance system, a requirement for sufficient assets for the development of higher education. (Bordoloi, 2018)

### **Methodology**

The objective of this paper is to finalize the outcome of the Distance Learning process during COVID-19 pandemic. A survey was created to get enough responses covering the area of students, teachers, and lecturers. This survey involved within students, teachers, and lecturers in Sri Lanka. The contribution of this study is to review the challenges and opportunities in Distance learning under the prevailing pandemic situation and to produce a framework which will overcome the challenges related to Distance Learning.

From the first stage of the survey the team have engaged with the research question based on the use of Distance Learning Technologies Efficiently in A Crisis/Pandemic Situation. In the second step, establish the identification of contents of the research papers which was read on the studies. In the third step the team have decided to do a survey based on the research question. In the fourth step gathered the analysed data which was collected from the survey. From the last step identified the last outcome based on the survey.

At first, testing was to decide the facilities of having adequate materials for both parties. And have looked up about the students' performance of online learning. The questionnaire comprised of using Distance Learning technologies efficiently in a crisis/pandemic situation. Information were collected within a google form and then placed into a database as in a excel sheet to follow and organize the information. The number of relevant forms after the survey

was exceeding 200. Quantitative data were deciphered using descriptive analysis. Based on questionnaire analysis and the study of the teaching and learning process quality, the main issues of introducing the Distance Learning principles were recognized. Our system was intended to eliminate the identified barriers.

From that quantitative data information, the team have gained most of undergraduates are contained within the Distance Learning process. Overall, this quantitative data was represented from the side of students are preferred to using distance learning technologies efficiently in pandemic situation. According to the lecturers and teachers, they prefer teaching in the classroom than using distance learning technologies, so the use of traditional teaching method is still requested by the teachers.

According to the survey, identified the enough materials for using technologies, modes of accessing, availability of enough connection and tools which are used for online

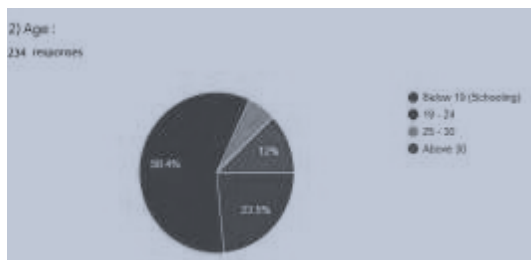

education. At the final stage we have identified the facts as having sufficient equipment and facilities to participate for online education, having sufficient IT skills and knowledge to manage, possibility of distractions from family background during online education and having a pleasure about the student-teacher or student-lecturer interaction during online education. In this context, it helps to identify the progress of using Distance Learning technologies efficiently during a Crisis/pandemic situation.

## Results and Discussion

The existing research papers won't discuss the situation occurred due to COVID-19 pandemic. Therefore, a well analysed survey is the best option to discuss the results and the modern conditions accurately. The questionnaire is conducted to identify influencing factors for the effectiveness of online learning and teaching during COVID-19 pandemic in Sri Lanka, according to the students, Teachers and lecturers' perspective. The questionnaire contains 10 main questions and under the question number 10 there are 10 more rating questions for the audience for the better understanding. The questionnaire was distributed among nearly 300 people and we had received 234 responses within a week targeting students' schoolteachers and university lecturers.

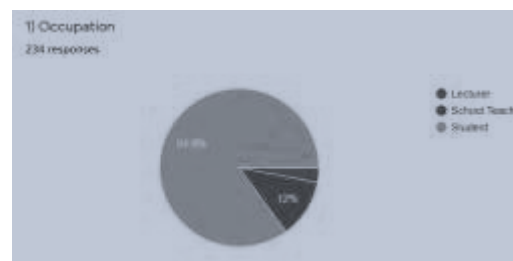

According to the results the majority are students and the percentage is 84.9% while the schoolteachers are 12% and university lecturers are 3.1%. It is a normal situation that majority are student who undergo several courses by that time. As the number of university lecturer count who has contributed to this questionnaire is in a lower level this research may basically discusses mostly about the learning during a pandemic situation.

The audience consists of various age limitations and majority (58.4%) is between 19 years and 24 years old. The rest divides as 23.5% are below 19 ,12% are above 30 and the least count is in between 25 -30 years old. As above the majority of the responders are students the survey further filters that among them 26% are from semi government

schools, 24% are from government universities, 24% are from private universities, 19% are from government schools and the rest is from private and international schools.

7) Mode of Accessing the LMS /VLE /Moodle/Student Portal /Blackboard /Zoom /Microsoft Teams :

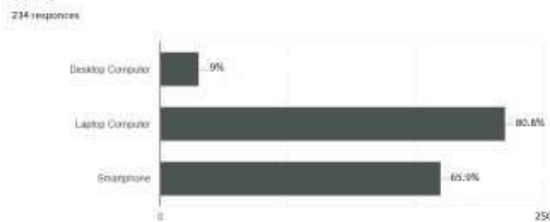

In this research for distance learning the user must have essential components to succeed and among them a device and a good internet connection is considered. According to the survey 96% of the audience have an internet connection at home and as the most used device laptops can be mentioned. 94% of the audience have a laptop and otherwise most of the students use their smart phones in accessing the Moodle. When considering the softwares the questionnaire shows how the audience interact with several popular softwares and applications during the pandemic. According to the bar chart graph zoom can be considered as the mostly used software application during the pandemic period and 85% uses it. There are many other software's used, but Zoom, Microsoft Teams, Google Classroom, Moodle/LMS/VLE are the software's which are popular among students, lecturers and instructors. Among those software's 53% of the audience uses Microsoft teams, 40% of the audience use Moodle/LMS/VLE/student portals and the rest use google classroom in advance.

9) What tools are you familiar with in online learning ?

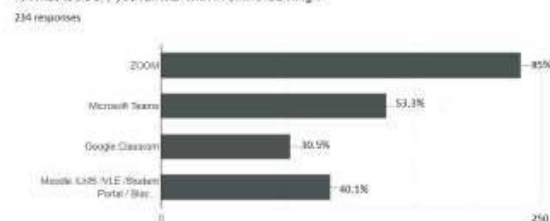

The survey showed more than 50% of the students and instructors were satisfied with enough equipment's and the facilities. Rest of

them has the issues with internet facility and data limitations even though they are consisted with enough computer literacy (71%). That is a serious issue but when the instructors use learn servers or another specific default server under the rules and regulations of the local Internet Service Providers that issue can be solved easily, and students can access their classes and lectures without data castration. When considering individual ideas of users who interacted with distance learning methods during the pandemic, most of the students (81.4) think distance learning is applicable in higher studies but teachers and instructors are not that much satisfied with distance learning.

By considering the overall survey results and existing research papers we can come to a conclusion that distance learning is the most relevant educational service which can be easily accessed by anyone anytime at anywhere. The lecturers and instructors must define creative and unique ways of giving and sharing their lecture modules with students. Assessments and online quizzes can be used to interact with students and as well as designing new software's that can be used in distance education which takes less amount of data while streaming and video conferencing would do a massive job in this sector.

### Conclusion

After thoroughly analyzing the data that contain in many research papers and the survey, could see that Using Distance learning technologies plays a huge role in the success in the field of higher education when a crisis occurs. The evolution of technology has become a huge impact to our future, the digital environment is capable of reshaping our world to a new direction and along with development with this evolving technology which has resulted into a range of benefits and opportunities. Though it looks like a perfect opportunity at first, when analyzing the data that we analyzed, that still some areas need further development. And still, some people are unable to facilitate these new technologies. through the survey

created, it received sufficient responses covering by the area of students, teachers, and lecturers. This survey involved students, teachers, and lecturers in Sri Lanka. The questionnaire was comprised of using Distance Learning technologies efficiently in a crisis/pandemic situation. Quantitative data were deciphered using this survey. Based on the questionnaires we recognized the distant learning principles. As per the given responses, 91.5% of students are using online education during this crisis. Age 19-24 students are mostly involving in the Distance Learning process.

According to the statistics mostly undergraduates are engaged within the Distance Learning process. Overall, data gathered from students preferred to using distance learning technologies efficiently in a pandemic situation. According to the lecturers and teachers, they preferred teaching in the classroom than using distance learning technologies. From this survey, we identified that there are not enough devices, connection to use the online education facility, technologies, modes of access, or tools which are used for online classes. There are so many limitations in the service of providing internet facility throughout some countries. Therefore, couldn't achieve that much of improvement in the field of higher education. Moreover, the lack of basic Informational Technological knowledge in rural areas is also make a huge impact on online education. As mentioned above this paper discusses the fact that student and teachers may lack their knowledge of using these technologies. lecturers are the ones who are responsible for delivering the knowledge for the student, as if they failed to go along with the evolving technology there will be a great loss in delivering their service. After going through the survey and the data that was collected one of the main points which was noticed is that the world is changing day by day rapidly. It takes a second to change everything, as a country, it needs to develop many areas. Together people can make a huge change in the country for the

success of education as education means the only available tool to develop one's own life. The contribution of this study is to review the challenges and opportunities in Distance learning under the prevailing pandemic situation and to produce a framework that will overcome the challenges related to Distance Learning. The research statistics are based on google form analytics for the moment and the team will be using a more advanced statistical tool for calculations (SPSS, Minitab) in the future to get highly accurate data which can be relied on for further efficient results.

## References

- (Bušelić, 2012) Angay, F. and Gulmez, M. (2012) 'education quality at an accounting program', 46, pp. 2733-2737. doi: 10.1016/j.sbspro.2012.05.556.
- Bordoloi, R. (2018) 'Transforming and empowering higher education through Open and Distance Learning in India'. doi: 10.1108/AAOUJ-11-2017-0037.
- Distance, S. et al. (2001) 'Research on Self-Efficacy of Distance Learning and its Influence to Learners' Attainments', 2001, pp. 1510-1517.
- El-seoud, M. S. A. et al. (2009) 'E-Learning and Students' Motivation: A Research Study on the Effect of E-Learning on Higher Education', pp. 20-26.
- Giovannella, C. (2020) 'Effect induced by the Covid-19 pandemic on students' perception about technologies and distance learning'. Effect induced by the Covid-19 pandemic on students' perception about technologies and distance learning', (May).
- Leontyeva, I. A. (2018) 'Modern Distance Learning Technologies in Higher Education: Introduction Problems', 14(10).
- Sun, A. and Chen, X. (2016) 'Online Education and Its Effective Practice: A Research Review', 15(September 2015), pp. 157-190.
- Tasdemir, A., Kus, Z. and Kartal, T. (2012) 'Out-of-the-school learning environments in values education: science centres and museums', 46, pp. 2765-2771. doi: 10.1016/j.sbspro.2012.05.562.

Xu, H. (2007) 'Digital Commons @ Butler University Effectiveness of Online Learning Program: A Case Study of A Higher Education Institution'.

### **Acknowledgement**

The completion of this task could not have been possible without the participation of many other people . Their contribution for this matter is highly appreciated and very gratefully acknowledged. The group would also like to express their gratitude and appreciation particularly to Mr. RPS Kathriarachchi for his support and encouragement towards this paper. It was a great privilege for the team for being able to do a research with him under his supervision and guidance. A thank you goes out to everyone who joined hands with us for the completion of this paper.

### **Author Biographies**

GGA Ranasinghe is a 3rd year undergraduate student of the Information Technology department at General Sir John Kotelawala Defence University. He was actively involved in creating the survey based on the topic and focused on the results and discussion in this paper. He also covered the area of completing the abstract and introduction.

KHNK Kumarasinghe is a 3rd year undergraduate student of Information Technology at General Sir John Kotelawala Defence University. Her work focused on the literature review and the results and discussions in this research

AHMD Somasiri is a 3rd year undergraduate student of Information Systems at General Sir John Kotelawala Defence University. She has covered the areas of literature review and the methodology in this research paper.

RT Wehella is a a 3rd year undergraduate student of Information Systems at General Sir John Kotelawala Defence University. She gives her contribution by completing the conclusion in this research paper and focused on the literature review.

Mr. RPS Kathriarachchi obtained his BSc (Hons) in Computer Networks from University of Wolverhampton UK and his master's degree in MIT in the same University. He also a CISCO certified network associate and having more than 15 years of IT and IS systems. His current research interests include Internet of Things, Machine Learning, SWARM technologies under his name.

## Focus Assistant: Identifying the level of motivation in computer users.

THDS Sugathadasa#, HL Premaratne, and LP Kalansooriya

*Faculty of Computing, General Sir John Kotelawala Defence University, Ratmalana, Sri Lanka.*

#sandeepisugathadasa@gmail.com

**Abstract:** Focus Assistant is a software that will help the user to be concerned about their health and refrain them from overworking and also will guide them back to work when they get distracted for a prolonged time. The system consists of two specific parts as the user should be alerted when distracted and the user should be notified to take a break if overworking. One of the main objectives of this paper is to identify the features and requirements that should be implemented in the system. The aim of this research was to reviews articles and other works related to the topic to get an understanding of the features that could be implemented in the system, and technologies that could be used regarding the system. By gaining a thorough understanding of the related work the expected results of the system would be that it helps the user to be focus on work by alerting them when they are distracted and as well as keeping their health unaffected in stressful work environments by asking them to practice some tasks such as to have water breaks, to move stretch and relax their muscles and take eye rests. There are software applications and systems that guide the user to take breaks if overworking and to practice ergonomic guidelines and also there are tools and chrome extensions that keep the user from getting distracted from their tasks. But Focus Assistant will be the first desktop application that would have both the options, so the user can focus on their health as well as not be distracted from their tasks for long periods. Finally, suitable features for the system are reviewed based on the information gathered from the related work.

**Keywords:** Focus Assistant, distracted, overworking

### Introduction

As technology has woven itself into the everyday lives of the people, it has transformed the mediums through which we interact, learn, and consume information. The use of computers as a tool in workplaces, academic institutions, recreation facilities, and homes has become very common. Undergraduates and especially people who work in the IT field spend most of their time in front of a computer or a laptop staring at the video display terminal popularly known as the computer screen. It is estimated that nearly 150 million computer users sit in front of a computer screen for hours each day. Unbeknownst to them, this extensive viewing of the computer screen can lead to serious health issues. Studies have shown an association between such prolonged computer usage could cause visual health- related symptoms such as Computer Vision Syndrome (CVS), and Musculoskeletal Problems, along with Repetitive Stress Injuries. Necessary precautions need to be taken to avoid these health issues that might impair the person for his/her lifetime.

Focus Assistant provides the user with the option of alerting themselves of such extensive computer usage. The purpose of this system is to prevent computer users from sitting in front of a computer or a laptop screen for a long period of time. The main focus is to develop a desktop application that reminds the user to get breaks while working, to follow proper ergonomic guidelines by prompting notifications to maintain correct postures and reminding them to keep themselves

hydrated by intaking water regularly. Focus Assistant mainly focuses on the young generation who tend to use computers and laptops regularly for studying, gaming, and other related work. The system would also provide users with the option of improving concentration while on the computer. The user may get distracted for a while, lose track of time, and will spend a lot of their time away from the work that must be completed. One cause of such distraction could be the other entertainment apps on the computer or the message apps. Focus Assistant would keep track of 'unnecessary' trips to these apps and take steps to alert the user of their distraction. Re-focussing will be prompted by notifications denoting the consequences of not finishing their work. For this, the user can adjust the desktop application to remind them in notifications when they get distracted from their respective work to something else in the device or to a different device like his/her mobile and also to ring an alarm when they been away from the computer for a long time, here the user can adjust the alarm to ring after a time duration.

Therefore the purpose of this study is to review the health issues that could cause by overworking in front of a computer and review existing software that has been implemented and gain a thorough understanding of how to implement a desktop application that addresses the both above-mentioned areas.

Objectives of this study:

- To identify what kind of systems are developed.
- To get a better understanding of the technologies that have been used when implementing these kinds of systems.
- To identify the features from the systems that have been developed.

### Literature Review

When an extended amount of time is spent in front of the computer, users are most likely to be at risk of developing certain health-related problems. Spending more than 4 hours each day in front of a computer

screen may have the risk of dying from a heart problem or being hospitalized according to a study conducted in 2011. (Julius and Mustapha, 2014)

Listed below are some of the health-related problems that may develop into greater issues if not dealt carefully; (Tucker, 2016)

#### Musculoskeletal Problems

Can occur in areas of the body such as back, neck, chest, arms, shoulders, and feet. Numbness may occur in the arms and hands. Happens because of the user's posture when using the computer being incorrect. When computer users attempt to interact with images or other sensitive content on a task, they tend to hold their heads off in bad postures which leads to neck, back, and shoulder pains.

#### Vision Problems

Constantly focusing on the screen with delays in blinking can result in dry eyes. Looking at the screen for an extended period can cause Computer Vision Syndrome, which is the eye muscles being unable to recover from the strain due to lack of rest. Eye strain results in a combination of various symptoms such as dry eyes, eye fatigue, headache, blurred vision, and also changes in the perception of color.

#### Repetitive Stress Injuries

Pain in the neck, shoulders, or from the shoulders to fingers due to repetitive muscle use. A most common condition related to repetitive use of muscles when using the computer is Carpel Tunnel Syndrome which is a common condition that causes pain, numbness, and tingling in the hand and arm.

#### Stress Disorders

Using tech devices every day has an impact on the emotions and behaviors of the user. Prolonged use of computers may develop poor health and increase the pressure placed on the user in their workplace, both of which could lead to stress. Stress leads to decreased attention span, lack of concentration, and dizziness (Tucker, 2016)

Longer the stress occurs and is left



untreated, the greater the chances of developing more serious health-related problems.

The above-mentioned health issues can be controlled by taking necessary steps to minimize the effects, such as;

- Taking small breaks from the computer work to move, stretch, and relax the muscles to keep the blood flowing every 30 minutes (York, 2017)
- Resting eyes by taking blink breaks from the screen every 20 minutes by gazing into a distance.

Taking 5 minutes to break from intensive computer operation in each hour is encouraged as a good practice (Julius and Mustapha, 2014)

- By following correct ergonomic practices.
- Taking a small water break to free your mind from stress at work and also as a practice to stay hydrated.
- If sitting for an extended time cannot be avoided, it is better to bend and move the body even while sitting.

One of the main purposes of the software that is to be implemented is for the user to focus on their health as much as the work that is needed to be done. So, the system that is yet to be implemented tries to grasp the above steps for the benefit of the user and by doing so it will increase the productivity and the efficiency of computer users.

Some of the existing apps and software that urge users to take a break from working are listed below;

#### *Take-A-Break Notification: An Ergonomic Application*

(Julius and Mustapha, 2014)

This is a software designed to reduce Computer Vision Syndrome (CVS) on office workers who are more likely to spend most of their time in front of a computer screen.

The main purpose of this work is to prevent computer users from looking in front of a computer screen for a long period of time. The project development phase has used Rapid Application Development as its methodology. It encourages the users to apply the ergonomic practices and to be able to reduce the increasing rate of CVS. This software allows the user to take a 5-minute break every two hours.

Eye Defender (Nova Vozrak, 2014)

The user can set periods of time between breaks and the duration of the breaks. When the set time gets triggered, the program activates a default screen saver according to the user's preferences, from its library or from a folder the user chooses as a reminder to stop working and take a break. It helps to prevent computer vision syndrome which causes from working on computers for long hours.

Off4Fit (Bjerke, 2014)

The software will remind the user to take rest and to do some exercises in front of the computer. A computer-generated image of a girl will demonstrate a set of various exercises for eyes, hands, and body, each repeated several times. The program allows the user to choose intervals between pieces of training, advised to keep the interval set to 60 minutes. The user can choose not to do the exercises if they don't feel like it, the breaks alone are helpful to the user.

Smart Break (Bjerke, 2014)

Monitors the time spent on a computer and prompts the user to rest at a specific time duration. This means the user can spend more time in front of a computer in a more efficient way by utilizing the break time.

Scirocco Take A Break (Nova Vozrak, 2014)

A software that reminds the user when to take a break. The features include customization of work, break times and snooze, audio or visual notifications, type of timer display, screen saver, the locking mechanism on break, time spent statistics, an average of break time per hour, and

motivational pie charts.

Above mentioned software are solutions to make users be more aware of their health to mitigate injuries or issues caused by working in front of the computer for long hours.

The other important section is to keep the user from getting distracted from their tasks for a prolonged period of time, so they can focus on their respected work and be efficient and productive with their work. Mostly university students tend to get distracted from their work often, some of the distractions can be listed as follows;

- Sleepiness
- Outside sounds/events
- Mobile phone
- Mind elsewhere
- A tendency toward some other task on the computer. Eg: social media, gaming
- Taking a break for a long time

Above mentioned distractions mainly occur due to less interest in the ongoing task that needs to be completed or by getting involved with some other activity during the short break. To minimize this type of occurrence software has been implemented for the benefit of the user's productivity.

Discussed below are some of the existing software that helps the user to work without getting distracted from their task;

Simpleology (Jacob Laguerre, 2017)

Is a digital productivity planner that helps the user to efficiently organize their day and stay on task despite many distractions. It is an online productivity tool with following features; it can block the access to social media sites and is consistent with a chrome extension called Dream Catcher which saves the random thoughts that comes to the user's head (Eg: what to buy at the store, what tomorrow holds, etc.).

Simpleology has two different modes: Simple Mode and Advanced Mode. In Simple Mode, it consisted of The Dream Catcher,

Start My Day, and Daily Targets. It also has a vision board where the user can add audios, videos, pictures, and gifs to help the user stay focused on their goals.

Inbox Pause (Connell, 2013)

A chrome extension which allows the user to pause incoming mail. The user can pause the inbox, answer the existing emails, and move onto their next task. The user can create a time to receive emails automatically so the user can block out time for productive work. Can get notified only about important emails.

Timers (*Pomodoro Technique*) (Connell, 2013)

The user can choose their task, set the timer for 25 minutes, and work on the chosen task. At the end of the 25 minutes, the user can take a break for 5 minutes.

Focus@Will (Connell, 2013)

A neuroscience-based music service that helps the user to focus, reduce distractions, and retain information when working, studying, writing, and reading.

The above-discussed software applications help the user to stay focused on their work without being distracted from the task.

Other related research works that can be used when developing the system are discussed below.

A non-intrusive method for user focus of attention estimation in front of a computer monitor. (Asteriadis et al., 2008)

This system estimates a user's focus of attention in front of the computer screen, by detecting and tracking the user's head position and eye movement using the web camera. It uses machine learning concepts to give real-time feedback on the user's attention by estimating the head position, eye gaze, and the distance of the user from the screen.

Mitigating distractions during online reading: an explorative study. (Copeland et al., 2016)

This paper presents a user study where

participants' eye gaze was recorded as they read the text in a visually distracting environment. Two distraction mitigation signals using real-time eye gaze data to investigate whether the effects help in reducing distraction rate and also aid recovery from distraction were explored. To show the reader where they have read up to, the signals involved adds a signal to the last word read before the distraction occurred.

The results demonstrate that the mitigation signals helped recovery from a distraction by drawing participants' attention back to the text as well as indicating where to recommence reading. (Copeland et al., 2016)

*Detecting Cognitive Stress from Keyboard and Mouse Dynamics during Mental Arithmetic* (Lim et al., 2014) Investigates how both keyboard and mouse features can be combined to detect human stress, particularly cognitive stress induced by time pressure and mental arithmetic problems.

The technology that has been used in this project is Statistical analysis of how the keyboard and mouse behavioral patterns change according to task demands.

Results: Shows the complexity of the mental arithmetic problem and time pressure affects the user's behavior, mouse behavior, and keyboard behavior. This indicates that the automatic analysis of human stress from keyboard and mouse input is useful for providing adaptation in interactive systems such as the e-learning system.

*Eye Gaze as an Indicator for Stress Level Analysis in Students* (Jyotsna and Amudha, 2018)

Demonstrating a system for the indication of mental stress using; the number of blinks, pupil diameter, and an indication of eye fatigue.

Two research questions were formulated and it has been tested against three hypotheses. Each hypothesis is validated with statistical analysis

When there is a large variation in the stress

level it can be indicated with a warning message and the corresponding participant can strengthen their stress management ability.

Camera-based Driver Distraction System using Image Processing (Rathod and Agrawal, 2018)

To reduce road accidents which is the main cause of driver distraction.

Haar cascade algorithm has been used for object detection in real-time.

Choose an efficient method to reduce road accidents due to driver's tiredness. Also increases passenger safety and gives information about the driver's behavior while driving and detects if the driver is intoxicated or not.

### **Methodology**

The system to be implemented consists of two specific parts; the user should be alerted when they get distracted from their work and the user should be notified to take a break when working for a prolonged period of time. The thought is to implement the systems separately and connect them to make a whole system that works separately.

#### **A. Phase I**

Is to implement the system which alerts the user when they get distracted from their work for a long period. By identifying the keystroke durations it can be detected whether the user is engaged on a task or not. But still, the user may be present but might be engaged in other related/non-related work on the device, to identify this the webcam is used to recognize whether the user is present in front of the device or not. Whether the user is doing some other work related to the main activity or whether he is distracted by something else on the device needed to be checked too. This can be a tricky situation to work on when developing the system.

The outcome of this system is to alert the user if they are distracted, by making an alarm sound, if the user is not present or by

notifying the consequences when they get distracted from their work for a long time. The user can keep a timer for a certain task and get a small break or they can set a timer for a few minutes to take a break from their work. The user can also keep notes of their work to be done (Eg: Deadlines, assignments) so they can get notified when they get too distracted.

#### B. Phase II

This phase consists of the implementation of the health concerned side of the Focus Assistant. When getting stuck on a task for a period the users tend to finish the task without taking a break or if the user is an office worker who has to be on their seats working for a long period, they hardly concentrate on their health as they want to get the work done somehow.

By monitoring the keystrokes of the user it can be identified whether they have been working for a long time without a break. Even if the keystrokes are not active by using the webcam of the device, the user's presence can be known.

The outcome of this system is to notify the user to take breaks from their work after a specific duration of time to practice minor exercises which doesn't take much of their time but will affect a great deal on their health.

Asking the user to do the following activities is the output from this phase of the system.

- Take small breaks from the computer work to move, stretch, and relax the muscles every 30 minutes.
- To rest their eyes by taking blink breaks from the screen every 20 minutes for 30 seconds.
- By asking to follow correct ergonomic practices such as stretching, standing up, moving your body time to time even while seated.

- Asking to take a small water break to free your mind from stress at work and also as a practice to stay hydrated.
- If the user is sensed to be stressed, ask the user to listen to a song or to have a small walk to get their mind off the stress and to make them work with a fresh mind again.

Finally, the overall system needs to be tested for errors and system touch-ups.

#### Discussion

From the review papers that were referred to during the conduct of the research, the most suitable features for the desktop application system are;

- Having an alert system to notify the user when they get distracted as well as when they are overworking.
- Keeping a notepad to keep track of the tasks they have.
- Notification prompter to notify the user to take breaks, exercise, or drink water.
- A timer, so the user could break their tasks into time frames to increase efficiency.

There are software systems that help and guide the users to take breaks and practice ergonomic practices in between their tasks and also there are tools that keep the user from not getting distracted for a prolonged period of time. But the system to be implemented will be the first system that would have both the options on, so the user can focus on their health if they are working too much or the user can keep themselves from not being distracted for periods of time. This research will be continued to produce the system.

#### Conclusion

When working on a laptop or a computer the user may get distracted for a while, lose track of time, and will spend a lot of their time away from the work that must be completed.

Distraction mainly happens because of the lack of attention towards doing a certain task. When get piled up with work, people lose interest to get them finished, which ultimately leads them to be panicked because of the less work that they have done, or sometimes they might get distracted because some other work with a high priority came up. Either way, the user gets mentally affected due to the lack of work they have performed.

In another case, the user might be working on their laptop without a break unaware of the time they have to spend in front of it, causing them to be physically and mentally tired.

The solution is to help them keep their physical and mental health unaffected while doing work, by alerting them on whether they need to rest or keep working. If the user has done enough work for some time then help them get a break from all the stress and help to get some small mental and physical exercises, to have them work more efficiently again. And if the user gets distracted from their work, then help by alerting the consequences they would have if the task isn't finished on time.

Focus Assistant is a software that will run on the background of the computer without hindering the user's work but will be monitoring the user with the users' consent. The system to be implemented is designed for the user to be focused on their work and also to help them be more vigilant on their health when working for a prolonged period of time

The user will be monitored with their consent, by the keystrokes on the keyboard and also using the web camera of their device to know whether the user is present in front of the device. If the user has been working for a long period of time then the system will send a message for the user to take a break from the work for a few minutes. If the user is not present in front of the device, or if the user is there using the device but distracted from their work for a

time period then the system will alert the user to get back to work that needed to be completed.

## References

- Asteriadis, S., Tzouveli, P., Karpouzis, K., Kollias, S., 2008. A non-intrusive method for user focus of attention estimation in front of a computer monitor, in: 2008 8th IEEE International Conference on Automatic Face & Gesture Recognition. Presented at the Gesture Recognition (FG), IEEE, Amsterdam, Netherlands, pp. 1-2.  
<https://doi.org/10.1109/AFGR.2008.4813330>
- Bjerke, N., 2014. Time to Take a Break. Time Take Break. URL  
[https://articles.informer.com/time\\_to\\_take\\_a\\_break.html](https://articles.informer.com/time_to_take_a_break.html)
- Connell, D., 2013. 6 Tools That Stop Computer Distractions and Help You Stay on Task. 6 Tools Stop Comput. Distractions Help You Stay Task. URL  
<https://www.wisebread.com/6-tools-that-stop-computer-distractions-and-help-you-stay-on-task>
- Copeland, L., Gedeon, T., Caldwell, S., 2016. Mitigating distractions during online reading: An explorative study, in: 2016 IEEE International Conference on Systems, Man, and Cybernetics (SMC). Presented at the 2016 IEEE International Conference on Systems, Man, and Cybernetics (SMC), IEEE, Budapest, Hungary, pp. 004830-004835.  
<https://doi.org/10.1109/SMC.2016.7844993>
- Jacob Laguerre, 2017. Double Your Productivity With Simpleology! Double Your Product. Simpleology. URL  
<https://www.pciinstitute.net/reviews/simpleology-review/>
- Julius, N., Mustapha, E.E., 2014. Take-A-Break Notification: An ergonomic application, in: Proceedings of the 6th International Conference on Information Technology and Multimedia. Presented at the 2014 International Conference on Information Technology and Multimedia (ICIMU), IEEE, Putrajaya, Malaysia, pp. 390-395.  
<https://doi.org/10.1109/ICIMU.2014.7066665>

Jyotsna, C., Amudha, J., 2018. Eye Gaze as an Indicator for Stress Level Analysis in Students, in: 2018 International Conference on Advances in Computing, Communications and Informatics (ICACCI). Presented at the 2018 International Conference on Advances in Computing, Communications and Informatics (ICACCI), IEEE, Bangalore, pp. 1588–1593. <https://doi.org/10.1109/ICACCI.2018.8554715>

Lim, Y.M., Ayesh, A., Stacey, M., 2014. Detecting cognitive stress from keyboard and mouse dynamics during mental arithmetic, in: 2014 Science and Information Conference. Presented at the 2014 Science and Information Conference (SAI), IEEE, London, UK, pp. 146–152. <https://doi.org/10.1109/SAI.2014.6918183>

Nova Vozrak, 2014. How to Prevent Eye Strain. Prev. Eye Strain. URL <https://articles.informer.com/how-to-prevent-eye-strain.html>

Rathod, V., Agrawal, R., 2018. Camera Based Driver Distraction System Using Image Processing, in: 2018 Fourth International Conference on Computing Communication Control and Automation (ICCUBEA). Presented at the 2018 Fourth International Conference on Computing Communication Control and Automation (ICCUBEA), IEEE, Pune, India, pp. 1–6. <https://doi.org/10.1109/ICCUBEA.2018.8697463>

Tucker, F., 2016. Top 10 Computer Related Health Problems. MicroHealth.

York, N., 2017. The Dangers of Sitting to Work: How Too Much Time in Front of the Computer Could Be Putting Photographers' Health at Risk. URL

<https://fstoppers.com/business/dangers-sitting-work-how-too-much-time-front-computer-could-be-putting-209431>

### Acknowledgement

I would like to express my highest appreciation and gratitude towards my supervisors Dr. HL Premaratne and Dr. LP Kalansooriya for their help in writing this paper. Dr. HL Premaratne, thank you for reviewing the paper and for your constant guidance and Dr. LP Kalansooriya thank you for the support and encouragement you gave. I'm eternally grateful for your support in making this idea a reality.

### Author Biographies



THD Sandeepi Sugathadasa is an undergraduate student in the Computer Science degree program at the General Sir John Kotelawala Defence University, Rarmalana, Sri Lanka and will be graduating in 2021 with a BSc(Hons) in Computer Science. Sandeepi

has a strong interest in the field of Human-Computer Interactions.

## Sri Lankan Currency Recognition Device for Visual Impaired People

AAAN Athapaththu#, WMSRB Wijayaratne, and DMR Kulasekara

*Department of Computer Engineering  
General Sir John Kotelawala Defence University*

# achininirasha7@gmail.com

**Abstract:** The identification of several currency denominations is not an easy task for people with visual impairments. In this document I present a Currency Recognition Device that can be used to help blind and visually impaired people to recognize the new range of Sri Lankan bills and verify whether if it is fake or not. The proposed system is based on simple image processing utilities and machine learning algorithms. The basic techniques used in this proposed system include image pre-processing, feature extraction and finally, the matching templates between the captured image and data set. The system easily identifies various currency conditions including occlusion, rotation, scaling, cluttered background, illumination change, and worn or wrinkled bills and counterfeit bills. The proposed system applies to Sri Lankan paper currencies, including six types of paper money. Therefore, in this supposed system I propose an efficient, portable and profitable banknote recognizer for Sri Lanka.

**Keywords:** Visual impairment, currency, recognition, Fake Detection

### Introduction

Visual impairments overwhelm a significant percentage of the population in several ways in Sri Lanka. According to current estimates, there are about 150,000 blind or visually impaired people in Sri Lanka. (Murthy et al., 2018). Being impairments of visually considerably affect the quality of life of those people and restrict many daily activities, especially the use of money in financial transactions. It is very easy for them to be

deceived by others. Today, these community uses several traditional methods to identify different currencies, which are not very effective, to identify different currency denominations. The monetary notes of Sri Lanka vary according to the images on two faces compared to the monetary notes in other countries. These images are quite complex and reflect the ancient heritage and culture of Sri Lanka. In addition, the introduction of a new series of banknotes poses a major challenge to the visually impaired in Sri Lanka, due to the functions available to identify the denomination are not effective for them. Visually impaired people have only one feature to recognize the value of different banknotes, which is a series of embossed dots that can be felt by touch. ("Sri Lankan rupee," 2019) But these dots get worn out with use. In addition, consecutive denominations only differ by 5 mm from each other and the difference is limited to the length. This difference of 5 mm in length is not enough for people with visual impairment to identify several denominations of new bills. ("Money and Costs in Sri Lanka - Lonely Planet," n.d.)

Despite intensive research in this field, many issues related to the currency recognition system remain unanswered even in Sri Lanka.

### Literature Review

Currency recognition for blind people is one of the most popular research problems that have developed in several ways. Many techniques have been used to implement the identification of several denominations

worldwide. Such as, a scanning device that uses sensor and segregation devices, identification using signal processing methods and applications based on image processing techniques.

#### A. Sensor Based Device

U.S.S.Perera and D.N.balasuriya proposed a bank note recognizer for visual impaired people in Sri Lanka.(Perera and Balasuriya, n.d.) The detection unit and the processing unit are main units in this device. The detection unit detects the color of two edges (from R, G, B) using two color sensors. As well as to increase the detection accuracy, system is equipped with a detection system with array of photo diodes or a group of photo transistors to detect intensities relative to each denomination. Then obtained data are classified with training data set using the k-Nearest Neighbor classification. As the training set, each banknote has 8 domains. So, all 6 denominations (20, 50, 100, 500, 1000 and 5000 rupee) has 48 domains. The Euclidean distance between the sensed parameters of the bill to be identified, according to the nearest neighbor method and compared with training data set. Then note detect. Finally, the output sends to the person as voice or vibrate. The system has an overall accuracy of 87.27%. But the drawback of this system is less effective in classifying the Rs.500 note which was erroneously classified as Rs.20. Unfortunately, the system cannot identify old series of bank notes and counterfeit bank notes.

#### B. Identification using Image processing technique

SLCRec is a desktop application for Sri Lankan currency notes that proposed by Gunaratna and others.(Gunaratna et al., n.d.) The proposed framework consists of two phases namely image processing phases and neural network phases. To start with, the scanned currency notes are converted into

gray scale from file format to pixel values. By having a linear combination of the previous values, a new set of values is generated from the original gray scale pixel values. Transformation function is used for this transformation. After that, performs edge detection to extract the identity of the image. Therefore, a special linear transformation function is used to remove noise on gray scale images, retrieve only the relevant characteristic patterns, re visualize prominent shapes in distorted image conditions, and obtain a fair representation of edges. Feature extraction is done by dividing an edge detected image into 20 rows in a height direction. This detected information is then extracted and processed into a model for the neural network. There are four classes coming out in the classification stage which are Rs.100, Rs.500, Rs.1000 and Rs.2000 notes. A three-layer back propagation neural network is presented with the number of edges detected in sequence of notes and the classification is accepted into four classes. Network is given expected outcome when notes with similar or slight differences are presented for classification. The system showed similar returns for reverse sides. It doesn't give superb edge detection for the 100-rupee notes at several times. Despite the fact that the system is not to identify forged notes. Network generalization doesn't work as well as one sided trained network. In addition, this system cannot identify new series of banknotes.

Hasanuzzaman and others have proposed a component-based framework for the recognition of US Bills using speeded up robust features (SURF).(Hasanuzzaman et al., 2012) This system is designed as a portable device for blind users by employing a portable camera or a camera on a phone, and images are captured in open environments with a large selection conditions including partial occlusion, highly



cluttered background, rotation, change of scale, illumination change, and wrinkling. The data set includes positive and negative images (background images without banknote). First, SURF extracts the monetary characteristics of each query image. These characteristics are combined with the precalculated SURF characteristics of the reference regions of the basic truth image in each category of banknotes. A total of 14 images of seven categories of bills (\$ 1, \$ 2, \$ 5, \$ 10, \$ 20, \$ 50 and \$ 100) with the front and back are taken as ground truth images. The number of matching features is compared with the automatic thresholds of each reference region to determine the category of bills. Then, the system issues the recognition result. If there is a currency in the camera view it use guide the blind user to correctly aim at the target, called spatial clustering. The supposed algorithm gains 100% true recognition accuracy for all seven categories and 0% false recognition rate. When the resolution of a query image is very low, the system cannot detect considerable points in the invoice. In addition, the proposed method cannot recognize the images of bills taken with severe blurred movements and bills with only one or none of the visible components.

A mobile application has used the image processing technique to recognize Egyptian banknotes for people with visual impairments. Noura A. Semary and others proposed this system. There are several techniques in this prosecco.(Semary et al., 2015) First, image acquisition. In this phase, the digital camera captures the image as an RGB image and converts to the grayscale version. Then, eliminate the noise in the image and quality is improve using the Gaussian blurring in the Pre-processing. To extract the paper money from the background, the image is being converted to the binary version. This is done by image segmentation phase. Then, the histogram

equation is used to change the contrast based on the image's histogram, change the brightness of the image and making the image more visible. In the ROI extraction phase, paper money is resized to the height of the data set. Finally, template matching based on the cross correlation between the captured image and the data set (values 1, 5, 10, 20, 50, 100 and 200 have been scanned on both sides). The application begins to read the database of saved currency notes and then begins to capture the fronted scene. Once both horizontal edges are detected, there is a vibrate effect to inform the user about the correct identification of money. After a while, a sound pronounces that the correct value in Arabic is hear. Experimental results show that the proposed method can recognize Egyptian paper money with high quality reaches 89%.

Rémi Parlouar has developed an assistive device to identify currency notes for blind people.(Parlouar et al., n.d.) The device is used webcam to capture image and use Spikent software to analysis the image. They use object models of a single image sample per invoice to recognize the € 5, € 10, € 20 and € 50 euro bills. In order to be preserve the selectivity in classification, they have selected each sample in a particular region of each currency, which contained characteristic projections that differ sufficiently from one currency to the other. To cover all orientations each sample was rotated by 12 ° steps. Finally, this results in 120 training samples for the four invoices. In the training model, the device was able to detect a range of three to ten centimeters on each bill (near the plastic strip) at a rate of five images per second, regardless of the orientation of the bill. As a classification of false positives had not been observed in the context of this experiment, at the 100% accuracy since all invoices were correctly identified. The drawback of the system is that the device takes longer to find the plastic

strip and fold the bill than the device actually use.

Suriya Singh and others adopt a computer-based approach to mobile devices and develop an application that can be run on low-end smartphones to recognize the currency of people with visual impairments.(Singh et al., 2014) They consider the bills of Indian National Rupee. Application recognizes the notes in two major steps. First, image segmentation is to reduce irrelevant characteristics that would affect to make decisions. Second, to classify the currency in the image, use an illustration pipeline. After segmentation, it detects SIFT key points within the foreground area of the image. Then, the application performs a tf-idf-based score of all the images in the data set using the inverted index and finds the ten best matches in the database. These images are spatially verified and reclassified. Then the audio message corresponding to the final result is played. If the result is wrong, the application again asks the user to capture another image. With this approach, applications have been able to report a recognition of 96.7% accuracy in the data set of the Indian rupee. The system gets incorrect answers, if the user's fingers cover part of the surface area, illuminating and fading the image and if the image is blurred or the currency is out of focus. There are two segmentation failures, one in which the background is not completely removed and the other is incorrectly marked as the bill background.

### C. Google APIs

Seeing AI is a free application designed for the blind and low vision community.(“Seeing AI | Talking camera app for those with a visual impairment,” n.d.) This ongoing research project harnesses the power of AI to open the visual world and describe people, texts and nearby objects. The application requires iOS 11. The application allows you to recognize short texts, documents, products, people,

currency, color, handwriting, light, images in other applications, photo browsing experience. Seeing AI is designed to help you achieve more by harnessing the power of the cloud and artificial intelligence. It is available in 70 countries, including Sri Lanka, as well as in supported languages, including English. This application is compatible with iPhone 5C, 5S and later and the best performance with iPhone 6S, SE and later models. The inconvenience of this application is only available in the App Store for iOS devices. Because most people in Sri Lanka do not use iOS devices.

LookTel Money Reader instantly recognizes the currency and gives voice output of the denomination, allowing people with visual impairment or blindness to identify and count bills quickly and easily.(“LookTel Money Reader for iPhone, iPod Touch and Mac,” n.d.) Point the camera of the iOS device to an invoice and the application will indicate the denomination in real time. The application is now available for iOS devices with iOS 4.0 and later versions and twenty-one bills are supported. LookTel Money Reader offers voice support for several languages, including English. LookTel Money Reader makes identifying invoices as easy as possible. It is not necessary to keep the iOS device still or capture a photo, since recognition occurs instantly, in real time. The application doesn't require an Internet connection, which means it will read money anywhere, anytime. The drawback of this application is that it is only for Apple devices. As well as it is not support for the Sri Lankan currency.

NantMobile Money Reader recognizes the currency and speaks the denomination, which allows people with visual impairment or blindness to identify and count bills quickly and easily.(Author, n.d.) The application will indicate the denomination of bank note in real time by pointing the camera of iOS device. Twenty-one coins are

supported. The application does not require an Internet connection, which means you will read money anywhere, anytime. It can be used to sort money quickly and easily with independence and confidence. NantMobile Money Reader offers voice support for several languages, including English. Disclaimer is this application should not be used to detect fake currency nor should it be relied upon solely for the identification of money. The application must be used with discretion, to guarantee privacy, as it announces denominations and displays denominations in large print. The light on most iOS devices can illuminate enough money to be visible to some extent.

Cash Reader identifies the denomination of the bills for the largest amount of coins. ("Cash Reader," n.d.) Point your camera at the money in hand and listen, see or feel its value. All bills supported by Cash Reader for some countries. The application is located in some languages. Open the application and place the currency in front of the camera. The denomination of the currency is read aloud instantly through the speaker of your device. At the same time, large contrast characters will appear on the screen. In silent mode, the denomination will be transformed into vibrations. This feature helps identify and count bills quickly even in noisy environments or when privacy is needed. Without the Internet, people can still use Cash Reader. After downloading the currency database, they do not need an Internet connection to read paper invoices, so user can now use the application anytime, anywhere. But this app is not available for Sri Lanka.

#### D. Identification using signal processing technique

The money detector is a device developed for the visually impaired people to identify the new range of bills in Sri Lanka. (Wickramasinghe and De Silva, 2013) The device use two unique manners to identifies the bank notes. The first way is

using a Light Dependent Resistor (LDR) sensors and Light Emitting Diode (LED) to detect the bank note. They are programmed to detect the color patterns of monetary bills. In this detection technique, it receives five analog input values. At that point five digital values are match with the predetermined color intensity ranges according to different banknotes and specified LDR. If the color detection system values are in the right range, the device estimates the length of the bills. In this method, The IR sensors connect to pins of the microcontroller directly. It provides a digital signal to the note placed in the device. Both values are verified with pre-determined data set. Then reproducing the identification message. This message runs through the inbuilt speaker system or via an optional headset. If the note is erroneously placed or blank paper is inserted, a blunder message will be played to the user. The length detection phase gave 100% accuracy. The only drawback was if monetary note be placed incorrectly it will play the error message. According to the following results observed, the final product gave 96.67% accuracy rate.

Barani.S has proposed a currency identification device for of Indian denominations (CiID) to help people with visual impairments using IR sensors. (Barani, 2015) This device observe the voltage level variation in the several currencies and detection has been implemented. A photosensor is paired with each infrared emitter, and six emitter-sensor pairs are integrated into the device. These pairs of devices are placed opposite each other with the same position on both sides of money that inserted. The complete module consists of three units. Processing unit, output unit and sensor unit. The purpose of the sensing unit is to capture input invoice information from an array of infrared LEDs. This information transmits to a processing module by corresponding phototransistors.

In the processing unit, the processor converts the sensor voltages into digital data. This digital data is compared to the data stored known bills currency. The processor determines the value of the currency, based on their similarities and differences. The database was created by maintaining the rupee in different orientations. The voice module will use output signals. The device is also tested with similar color fake bills. Therefore, according to the scan result, the accuracy is estimated at 86%. Since the light sensitive sensors used, the design of the device must such that the intensity of the light doesn't affect the device performance.

According to the review of existing systems, money recognition systems can be classified into two main areas, as follows: a scanner-based device, that using sensors and segregation devices. And applications, based on image processing and signal processing techniques. I discovered that image processing techniques and currency classification based on machine learning is one of the most used methods in camera-based devices. But the main problem with the camera-based device is that it cannot recognize the images of bills taken with severe blurred movements and bills with only one or none of the visible components. According to my study, The RGB color-based classification had also been used in a sensor-based device to classify monetary notes based on the fact that in each note, only one of these color components is exceptionally prominent. According to the review, the main problem with the scanner-based device is that blind people cannot place the currency correctly in the device. Otherwise, the system gives an incorrect output. However, some other technique is signal processing. In this model, the variation in the voltage level of several currencies is observed and detected to implement this device. Although there are several Google API's available in app stores. But all these applications can only run the

iOS platform. As well as most of these systems can be identified with a particular currency that is unique for their country. In addition, systems cannot identify counterfeit bills.

According to the review of existing systems, most portable devices are camera-based devices with image processing techniques and machine learning algorithms. Just as profitability and portability are also high in those devices than in others.

### Methodology

In order to design an effective banknote recognizer our first goal was to create a software phase to currency recognition. The proposed system consists of two phases. Image processing phase and machine learning phase.

#### Image Processing Phase

The system work on the image of currency note acquired by a digital camera under ultraviolet light. The image processing techniques that is applied here is as follows.

Acquisition of live image of monetary note by simple digital camera under ultraviolet light. The input image is pre-processed to remove noise and enhance the quality. Then characteristics features will be cropped and segmented of the paper currency. After segmentation, characteristics are extracted of the note. Then the output image is matching with training data set.

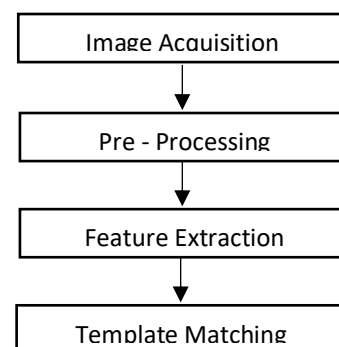

Figure 40. Image Processing Phase

## Machine Learning Phase

The system matching the live image with training data set to identify denomination of currency. System trained using Convolutional Neural Network. There are six classes coming out in the classification stage and they are Rs.20, Rs.50, Rs.100, Rs.500, Rs.1000, Rs.5000. The neural network is trained with 6 kind of different currency notes acquired under UV light on different angles and different conditions. After training the data, validate it on the validation data. Once we are satisfied with the model's performance on the validation set, we can use it for making predictions on the test data. The machine learning techniques which is applied here is as follows.

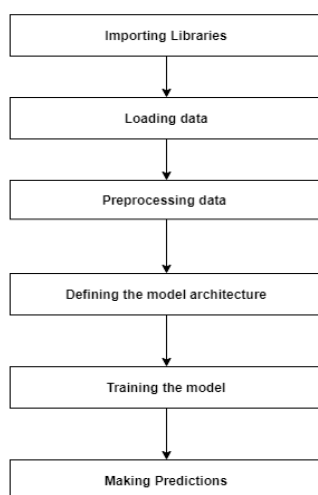

Figure 41. Machine Learning Phase

## Conclusion And Future Works

Segregation and money counting are not painless work for the community without vision. Several countries have different bill identifications for people with visual impairments. Most countries don't have an adequate equipment to meets this purpose. The visually impaired people have its own identification technique, that solves their challenge in currency identification. To address this problem, I assumed a system to develop a currency recognition device to solve this crisis and make blind people feel secure and confident in financial business. In this supposed system, several steps have

been taken to develop portable and low-cost banknote recognizers. Here, the currency is trained to be recognized and verified using image processing techniques and machine learning.

In future work, I will build the hardware component. The device is literally a simple computer that includes input, a processing session and output. The brain or the processor is Raspberry Pi module, because it gives low cost, compatibility and effective power consumption for this device. Firstly, currency note inserts into the device. Acquisition of image of currency note under ultraviolet light inside the device. It will avoid acquired blurred images and capture all the visible components. After image is matching with training data set. Finally, the device given voice output about Denomination of currency and If it is fake currency or not. User can hear the voice using headset also. My future work will focus on evaluating the proposed system to identify a currency recognize device for visually impaired people in Sri Lanka.

## Reference

Author, A.S., n.d. NantMobile Money Reader by IPPLEX [WWW Document]. AppAdvice. URL /app/nantmobile-money-reader/417476558 (accessed 11.3.19).

Barani, S., 2015. Currency identifier for Indian denominations to aid visually impaired, in: 2015 International Conference on Circuits, Power and Computing Technologies [ICCPCT-2015]. Presented at the 2015 International Conference on Circuit, Power and Computing Technologies (ICCPCT), IEEE, Nagercoil, India, pp. 1–4. <https://doi.org/10.1109/ICCPCT.2015.7159392>

Cash Reader: Bill Identifier [WWW Document], n.d. . App Store. URL <https://apps.apple.com/us/app/cash-reader-bill-identifier/id1344802905> (accessed 11.3.19).

Gunaratna, D.A.K.S., Kodikara, N.D., Premaratne, H.L., n.d. ANN Based Currency Recognition System using Compressed Gray Scale and

Application for Sri Lankan Currency Notes-  
SLCRec.

Hasanuzzaman, F.M., Yang, X., Tian, Y., 2012.  
Robust and Effective Component-Based  
Banknote Recognition for the Blind. IEEE Trans.  
Syst. Man Cybern. Part C Appl. Rev. 42, 1021-  
1030.

<https://doi.org/10.1109/TSMCC.2011.2178120>

LookTel Money Reader for iPhone, iPod Touch  
and Mac [WWW Document], n.d. URL  
<http://www.looktel.com/moneyreader>  
(accessed 11.3.19).

Money and Costs in Sri Lanka - Lonely Planet  
[WWW Document], n.d. URL  
<https://www.lonelyplanet.com/sri-lanka/a/nar-gr/money-and-costs/357442> (accessed 11.3.19).

Murthy, G.V.S., Gilbert, C., Schmidt, E., Mahipala,  
P.G., Gamage, K.M.K., Banagala, C., Abeydeera,  
A.P., Jeza, A., 2018. The Sri Lanka National  
Blindness, Visual Impairment and Disability  
Survey: rationale, objectives and detailed  
methodology. Ceylon Med. J. 63, s3-s9.  
<https://doi.org/10.4038/cmj.v63i5.8735>

Parlouar, R., Dramas, F., Macé, M.J.-M., Jouffrais, C.,  
n.d. Assistive device for the blind based on object  
recognition: an application to identify currency  
bills 2.

Perera, U.S.S., Balasuriya, D.N., n.d. SRI LANKAN  
CURRENCY NOTE RECOGNIZER FOR VISUALLY  
IMPAIRED PEOPLE 4.

Seeing AI | Talking camera app for those with a  
visual impairment [WWW Document], n.d. URL  
<https://www.microsoft.com/en-us/ai/seeing-ai>  
(accessed 11.3.19).

Semary, N.A., Fadl, S.M., Essa, M.S., Gad, A.F., 2015.  
Currency recognition system for visually  
impaired: Egyptian banknote as a study case, in:  
2015 5th International Conference on  
Information & Communication Technology and  
Accessibility (ICTA). Presented at the 2015 5th  
International Conference on Information &  
Communication Technology and Accessibility  
(ICTA), IEEE, Marrakech, pp. 1-6.  
<https://doi.org/10.1109/ICTA.2015.7426896>

Singh, S., Choudhury, S., Vishal, K., Jawahar, C.V.,  
2014. Currency Recognition on Mobile Phones, in:  
2014 22nd International Conference on Pattern  
Recognition. Presented at the 2014 22nd

International Conference on Pattern Recognition  
(ICPR), IEEE, Stockholm, Sweden, pp. 2661-2666.  
<https://doi.org/10.1109/ICPR.2014.460>

Sri Lankan rupee, 2019. . Wikipedia.

Wickramasinghe, K., De Silva, D., 2013. Bank  
notes recognition device for Sri Lankan vision  
impaired community, in: 2013 8th International  
Conference on Computer Science & Education.  
Presented at the 2013 8th International  
Conference on Computer Science & Education  
(ICCSE), IEEE, Colombo, Sri Lanka, pp. 609-612.  
<https://doi.org/10.1109/ICCSE.2013.6553981>

## Monitoring mental health of Sri Lankan youngsters during COVID 19 with passive mobile sensing

KAAB Gunarathne<sup>1#</sup>, KPN Jayasena<sup>2</sup>

<sup>1</sup> Department of Computing and Information Systems, Sabaragamuwa University of Sri Lanka, Belihuloya, Sri Lanka, *kaabgunarathna@std.appsc.sab.ac.lk*

<sup>2</sup> Department of Computing and Information Systems, Sabaragamuwa University of Sri Lanka, Belihuloya, #Sri Lanka, *pubuddu@appsc.sab.ac.lk*

**Abstract:** Smartphones are the key things that offer the collection of behavioral data without knowing the users because it is the most closest and frequently used accessory of daily life. The youngsters in Sri Lanka who are suffering from mental illnesses are not aware of their disease as well as the symptoms. In this article, our main aim is to monitor the behavior of the young people in Sri Lanka at the time of COVID 19, and come up with an analysis of the mental health status and about the symptoms of mental disorders that they are showing. Data can be collected in various ways like, from the default sensors and questioners. Mobile phone usage patterns like the duration of time spent at various locations are the factors that may provide evidence for their behavior. In addition, the daily activities like physical activity and sleep are also affected by these defined mental disorders in this pandemic time. We hope that we could provide the sufficient remedies for those who suffer from mental disorders during COVID 19 with the use of data collected through the sensors and surveys. We ensure the security features when receiving the sensitive data. We think through smartphone sensing, we could contribute to avoiding obstacles in behavioral studies specially in the area of mental health detection.

**Keywords:** Smartphone sensing, mental health, Behavioral Science

### Introduction

During this pandemic of COVID 19, most of the people have changed their living patterns. Set of them are alone because of social distancing. The mental health issue of society will surely take place at this pandemic. Moreover, technology for mobile sensing is now evolving at an incredible pace. The mobile provides a healthy range of sensor choices for social environment sensing. Different location and context-related sensors and network technology are integrated into mobile phones such as GPS, WLAN, cellular network antennas, Bluetooth, accelerometers, magnetometers, gyroscopes, barometers, proximity sensors, humidity sensors, temperature sensors, ambient light sensors, cameras, microphones, and so on. With this variety of input or stimulus choices, combined with capable computational and networking capabilities, the smartphone becomes an enticing "cognitive" medium with great potential for achieving sufficiently high intelligence to answer social context issues such as "Where are you?" "What do you do?" "What do you feel like?" "Who is with you?" "What's going on?"

Typically, built-in sensors of a smartphone such as an accelerometer, magnetometer, and gyroscope can be utilized to calculate the smartphone's speed, heading, orientation, or motion mode. Also, the camera in a smartphone is a potential positioning sensor. In general, human physical activity recognition using Microelectromechanical

system sensors has been extensively applied for health monitoring, emergency services, athletic training, and navigation.

The convergence of IT with the human lifestyle has improved the quality of human life. This emerging technology has resulted in a digital transformation of management, diagnosis, and treatment in the health sector. In this transition, smart device technology is one of the main facilitators. Taking advantage of the ability of smart devices to track different human activities such as tracking sleep patterns, daily water consumption, weight loss reporting, and heart rate monitoring to improve people's lifestyles and health conditions.

Specific implementations for these purposes have been suggested. The World Health Organization (WHO) defines health as “a state of complete physical, mental and social well-being and not merely the absence of disease or infirmity” defined health. Smart devices, for patients with anxiety or depression, have been widely used to monitor mental health. Mental health refers to the well-being of people who cope with stress, who are more successful in their lives, and who contribute positively to their community. Anxiety is an emotion characterized by an uncomfortable state of inner turmoil, frequently accompanied by anxious behavior, such as back and forth pacing and somatic complaints. Depression is a chronic mood disorder that results in severe symptoms that affect the feelings of people and their daily activities, such as working, eating, or sleeping. About 300 million people worldwide suffer from depression, 4.4% of the world's population. WHO has ranked anxiety disorders as the sixth cause leading to global disability (3.4% of people with disabilities in 2015); while depression has been ranked as the single major cause of global disability (7.5%). Also, during this COVID 19 time, it may raise.

Depression is also the main contributor to deaths from suicide, almost 800,000 cases a year. Depressed people share common symptoms with anxious people, such as increased heart palpitation, feeling lonely most of the time, and losing energy at various levels. Scores generated by surveys such as Patient Health Questionnaire (PHQ), the Center for Epidemiologic Studies Depression Scale-Revised (CES-D), and Beck's Depression Inventory (BDI) are the standard approaches for diagnosing and screening anxiety and depression. Different health applications have been proposed, especially for mental health, to help many people with symptoms of anxiety or depression use smart devices as an alternative to sustaining or improving their mental health. Developed countries have built some applications for evaluation purposes using algorithms that implement a series of user-submitted questionnaires to obtain possible diagnoses.

### **Methodology And Experimental Design**

The main objective is to make a mobile phone application to monitor the behavioral patterns of individuals during this pandemic and monitor their mental wellbeing from the datasets acquired via the developed application. This app may use mobile phone sensors to monitor behavioral patterns. The data sets are the most valuable assets. We are Focusing on Sri Lankan youngsters who have smartphones. Because in this COVID 19 pandemic situation, all of the people are in their houses and smartphones are a good medium to reach them remotely. There are no studies to monitor mental health that can be used by Sri Lankans. It was the main reason for which they do not know about the importance of mental wellbeing. A high percentage of people do not face dangerous mental health issues like Apotemnophilia, Boanthropy, and Capgras Delusion. Most of the time they face general disorders like anxiety, depression, and stress. Therefore, we needed to know the basic behaviors of



people who have these disorders. In those instances, we can collect the relevant information. Through this analyzed data set, authorities can organize events by focusing them to minimize the disorders. Alternatively, we can build a platform among mental health doctors and mental health patients.

We decided to use a smartphone sensing methodology to succeed in this data acquisition. The main problem of unawareness about mental health conditions is the lack of use of ICT based solutions. The smartphone is a successful method to monitor behaviors since it is always in the hands of people. Smartphone sensors replace the unwanted questionnaires that have not effective output and also that will disturb the user's day to day life. We are focusing on passive sensing through smartphones to monitor the movements and activities. It means that this methodology does not need the force of the user. Sometimes this data is obtained without knowing the user. This methodology has a high effect on behavioral science since it can monitor the targeted individual in any amount of days and any amount of hours. Also, every single data recorded. A smartphone has some accessible sensors like Accelerometer, GPS, Light sensor, Microphone, Bluetooth, Antenna, and Proximity sensor. Also, we can access logs such as Call logs, Device activity, SMS patterns, Application usage, and Calendar. Therefore, We plan to access this sensor and manual data through a mobile application developed and analyze. The monitoring process is supposed to be done for about three weeks with a sample.

To measure the depression of any user, the sleep patterns are necessary factors. So that information about the sleep patterns should be very well accurate and reliable. So we are planning to send push notifications to users to get information about their daily sleep

patterns. This push notification will be sent every morning. These push notifications consist of multiple-choice questions that will help to conclude the depression level. It will be a short reliable form that will not consume the user's time in a high manner.

Mainly we focused to access smartphone in-built sensors like GPS and Accelerometer to detect the behavioral patterns of the user. The mobile phone will monitor the movements and activities at equal time intervals all over the day. The IMEI number will be used as the primary key to identify the user. Each data will be sent to the backend with the IMEI of the smartphone.

The next step is to ensure the privacy of the target user. The most common limitations in this type of study are security and privacy issues. To overcome this, I am not using any names of users for any identification purpose. Using the IMEI number of the device is a good solution for this gap. Or else we can get some amount of summarized data without any individual data. We will not record sensitive data like call records, Photos, and others. More sensitive data will not be uploaded separately.

We asked 20 participants from August to September 2020 via online and verbal communication methods. They are good to go with this study if they have a smart-phone which have android 9 or below (Api Level<28), email account, active internet connection which has connection approximately all over the day, have the ability to read and understand Sinhala and English, still in the age range of 20 to 30 years who are representing the young generation. All participants in this study have participated with a volunteering basis with the mindset of contributing to the healthy outputs to the community with the effectiveness of this research. The eligibility of any user has been reviewed with the above-mentioned criteria before the study

with online communication methods and direct verbal communication.

In the first step of this research, participants were requested to install the Activity recognition Application (Described in the below section) and check the working condition of the application for their specific android device. Devices who have special limitations for the sensors were neglected from the study. After installation users are asked to complete a survey that is used to monitor the depression of individuals. This survey consists of questionnaires that are approved by the world health organization and also used by psychiatric doctors in Sri Lanka. So the standards of the survey are in a high place. This also an online assessment in which the user records are recorded online. The user should not reveal any of their identity for the best practices of privacy.

#### A. Activity recognition Application

This is an Android app that we developed to get and process mobile phone sensor data. The app basically gets the data from the accelerometer and GPS location sensor. It tracks the users' behaviors and all the accessing sensors are got used after the user gives permission to track. This application runs in the background and checks for the location in equal time intervals. It will send the location data to a realtime firebase database. In addition, we accessed the accelerometer and got the users' physical activity. This is another perspective we can measure the behavior of the individuals. We can assure the accuracy of the activity since the accelerometer data are processed and returned the activity by the Google activity recognition API. With this sensor data, the application gets the sleep pattern of every user in every morning it is a very simple tickable multiple choice question that reminds the users via the push notification feature in every morning.

This application is completely designed and developed by us and it can be mentioned as contributions to the study. We have made it open source so that any research people or students get used to it in the future.

With the behavioral patterns of mental health patients and random people, we can analyze and provide detailed information about any individual who may have mental disorders or have symptoms based on the behavioral data got from mental health patients. The final idea is to analyze the data and to take immediate necessary steps to raise people's mentality that was affected during COVID 19. Also, to help the doctors to identify mental health patients through the behavioral data coming from this application.

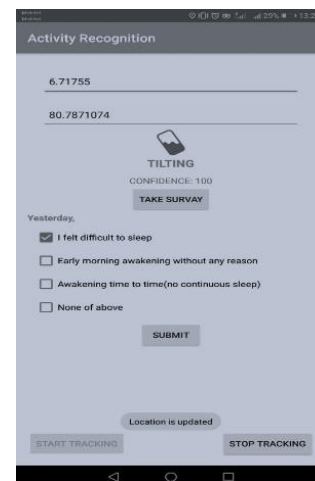

Figure 1. Application overview

### Progress And Expected Results

#### A. Progress

We have built a mobile application for the data collection scenario. we have done the testing of the application. And also the accelerometer is the other most critical sensor available on our mobile phones. It will send us the activity of the user. The activities are mainly driving, still, walking, Tiltin, running, and unknown. It is also included in the application. The sleep pattern and the depression survey also mentioned inside the same application. To maintain these

standards the mentorship of the experts is needed. we can get questions from related websites. But we cannot assure them about their accuracy by 100%. So that I have got supports from doctors who are experts in mental health-related issues in the district hospital Bandarwela. They have given us the WHO-approved depression surveys and scales. These survey data can be used to ensure the mental health condition that will return from the behavioral data.

We have started collecting the data from all perspectives above mentioned. And the study is Ongoing.

### B. Expected results

Accurate, reliable, and analyzed data set of random Sri Lankan youngsters that can be used to overcome the mental health issues during the COVID 19 pandemic. We are looking forward to analyzing the data acquired by sensors and surveys and get the behavioral pattern of individuals. It will be compared with the behavioral patterns of the depressed people and through this study, we will be able to represent critical behavioral patterns that young people in Sri Lanka. Through this analysis, the behavioral patterns of depressed youngsters will be revealed.

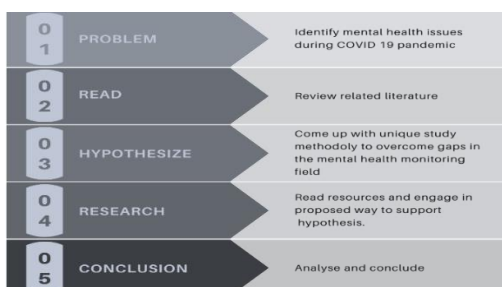

Figure 2. Stages of study

## Acknowledgment and references

### A. Acknowledgment

I am grateful to all who have supported me in this study specially my university supervisor DR.KPN Jayasena for guiding me in this path. And also specially thanks for DR.Upul

Ranasingha for helping me from the clinic side and helping me to maintain the standards and the quality of questions that will send through the mobile application. And also I should thank him for helping me to get a well-analyzed data set from vast range of data that could be collected from users. And for all who have spent time on my study.

### B. References

Chiang, I.P. (2019). Exploring Smartphone Users' Social Information Behavior. *Contemporary Management Research*, 15(1), pp.53–67.

Ghosh, S., Hiware, K., Ganguly, N., Mitra, B. and De, P. (2019). Emotion detection from touch interactions during text entry on smartphones. *International Journal of Human-Computer Studies*, [online] 130, pp.47–57. Available at: <https://www.sciencedirect.com/science/article/pii/S1071581918304889> [Accessed 3 Jul. 2019].

Grunerbl, A., Muaremi, A., Osmani, V., Bahle, G., Ohler, S., Troster, G., Mayora, O., Haring, C. and Lukowicz, P. (2015). Smartphone-Based Recognition of States and State Changes in Bipolar Disorder Patients. *IEEE Journal of Biomedical and Health Informatics*, 19(1), pp.140–148.

Huang, K., Ding, X., Xu, J., Chen, G. and Ding, W. (2015). Monitoring Sleep and Detecting Irregular Nights through Unconstrained Smartphone Sensing. *2015 IEEE 12th Intl Conf on Ubiquitous Intelligence and Computing and 2015 IEEE 12th Intl Conf on Autonomic and Trusted Computing and 2015 IEEE 15th Intl Conf on Scalable Computing and Communications and Its Associated Workshops (UIC-ATC-ScalCom)*.

Majumder, S., Mondal, T., and Deen, M. (2017). Wearable Sensors for Remote Health Monitoring. *Sensors*, [online] 17(12), p.130. Available at: <https://pdfs.semanticscholar.org/9f3c/8283e8a0232536f83a13b8028f7813dd676a.pdf> [Accessed 25 Apr. 2019].

Morganstein, J. (2016). Mobile Applications for Mental Health Providers. *Psychiatry*, 79(4), pp.358–363.

Pei, L., Guinness, R., Chen, R., Liu, J., Kuusniemi, H., Chen, Y., Chen, L., and Kaistinen, J. (2013). Human Behavior Cognition Using Smartphone Sensors. *Sensors*, 13(2), pp.1402–1424.

Shrestha, A., Dang, J., Nakajima, K. and Wang, X. (2019). Image processing-based real-time displacement monitoring methods using smart devices. *Structural Control and Health Monitoring*.

YOUN, C.-H., KIM, J., SONG, H., KIM, D., and SHIM, E.B. (2007). Informant Driven e-Health Service for Identification of Heart Rate Changes from Mental Stress. *IEICE Transactions on Information and Systems*, E90-D(12), pp.2104–2107

Saeb, S., Zhang, M., Karr, C., Schueller, S., Corden, M., Kording, K. and Mohr, D., 2020. Mobile Phone Sensor Correlates Of Depressive Symptom Severity In Daily-Life Behavior: An Exploratory Study.

### Author Biographies



I am K.A.A.B. Gunarathne an undergraduate of Department of Computing and Information system, Sabaragamuwa university of Sri Lanka. I am following Bachelor of Science (Special) Degree in Information Systems. I have experiences in developing mobile applications and I like to expand them and my other skills to do this study during the COVID 19 pandemic.

